



Washer, Electrical Equipment Bond

# WEEB

## INSTALLATION INSTRUCTIONS

*For Orion Solar ORI-R Rail  
Mounting System Only*

Please read carefully before installing.

Burndy LLC recommends that the sufficient details of the installation be submitted to the AHJ for approval before any work is started.

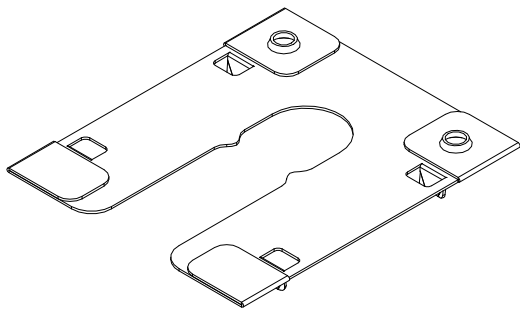

WEEB-OCR

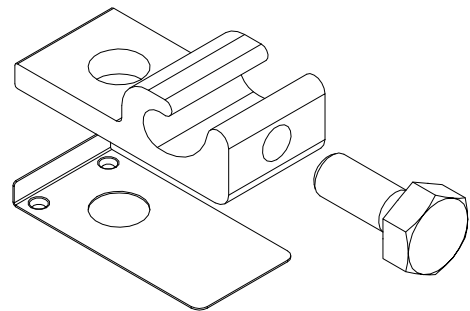

WEEB-LUG-8.2

Products are tested to UL 467, CAN/CSA-C22.2 No. 41  
US/ Canadian standards for safety grounding and bonding equipment.



Intertek  
3098177

# WEEB COMPATIBILITY

The WEEB family of products can be used to bond anodized aluminum, galvanized steel, steel and other electrically conductive metal structures. All installations shall be in accordance with NEC requirements in the USA and with CSA C22.1 in Canada. The WEEBs are for use with modules that have a maximum fuse rating of less than 25A.

## WEEB-OCR on Boxed Module Frames:

Certain module frames do not have enough structural strength to withstand the force required to embed a WEEB. These frames will deform and therefore not allow sufficient penetration of the WEEB teeth. The general requirements for minimum module frame thickness of "boxed" type module frames are illustrated below. For more information regarding module compatibility, please see the technical documents section of our website.

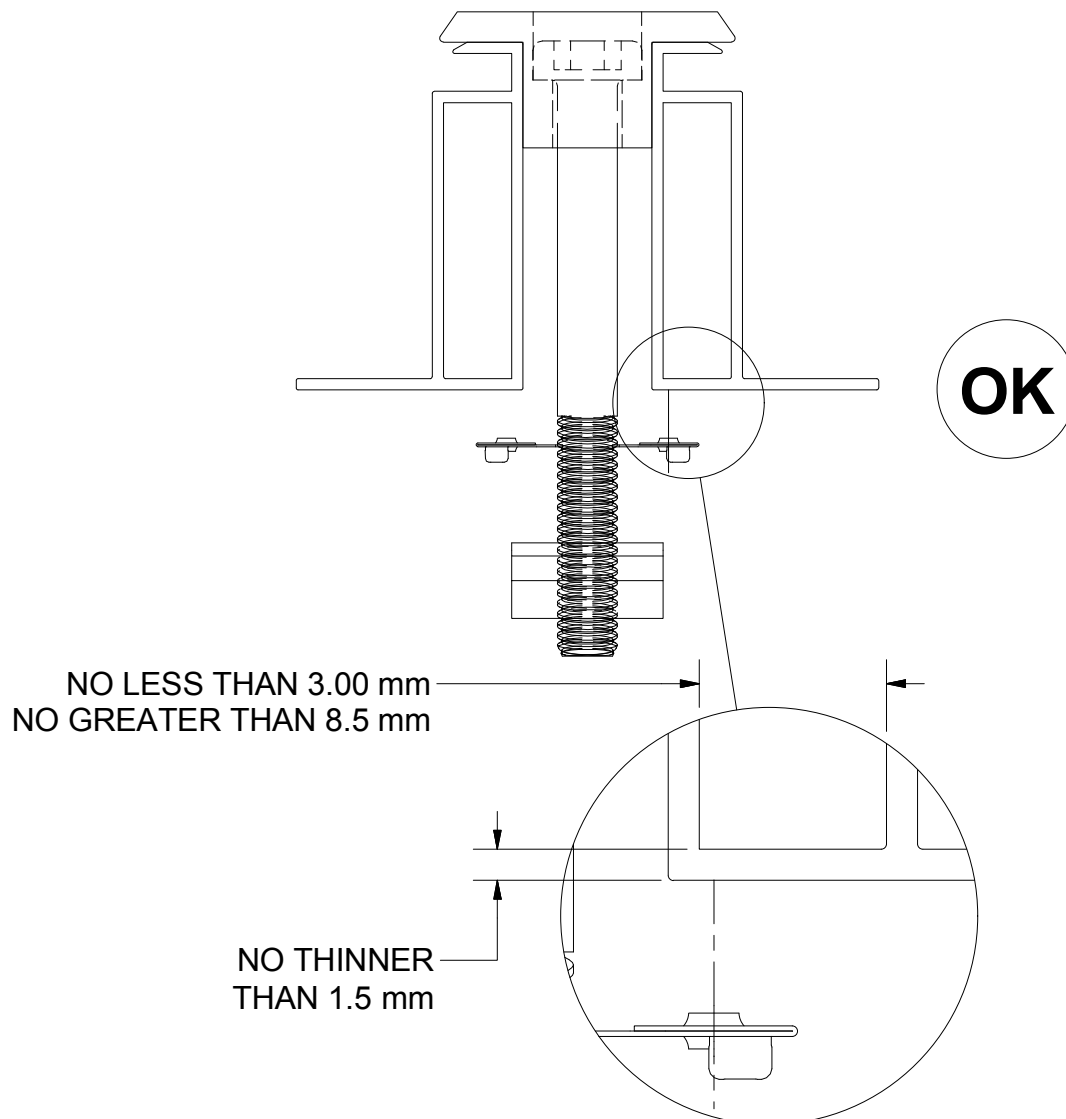

### Note:

Inspect each module frame used with a WEEB to ensure that the bottom mounting face of the frame is flat, and that there are no hindrances to embedding WEEB teeth. Do not use a module with a frame that prevents the WEEB teeth from embedding fully.

# SYSTEM OVERVIEW

Lay in equipment ground conductor and torque bolt to 7 ft-lbs / 10 N-m.

Use one WEEB-Lug-8.2 assembly per rail to connect system to equipment ground conductor. Torque fastener to 12 ft-lbs / 16.3 N-m.

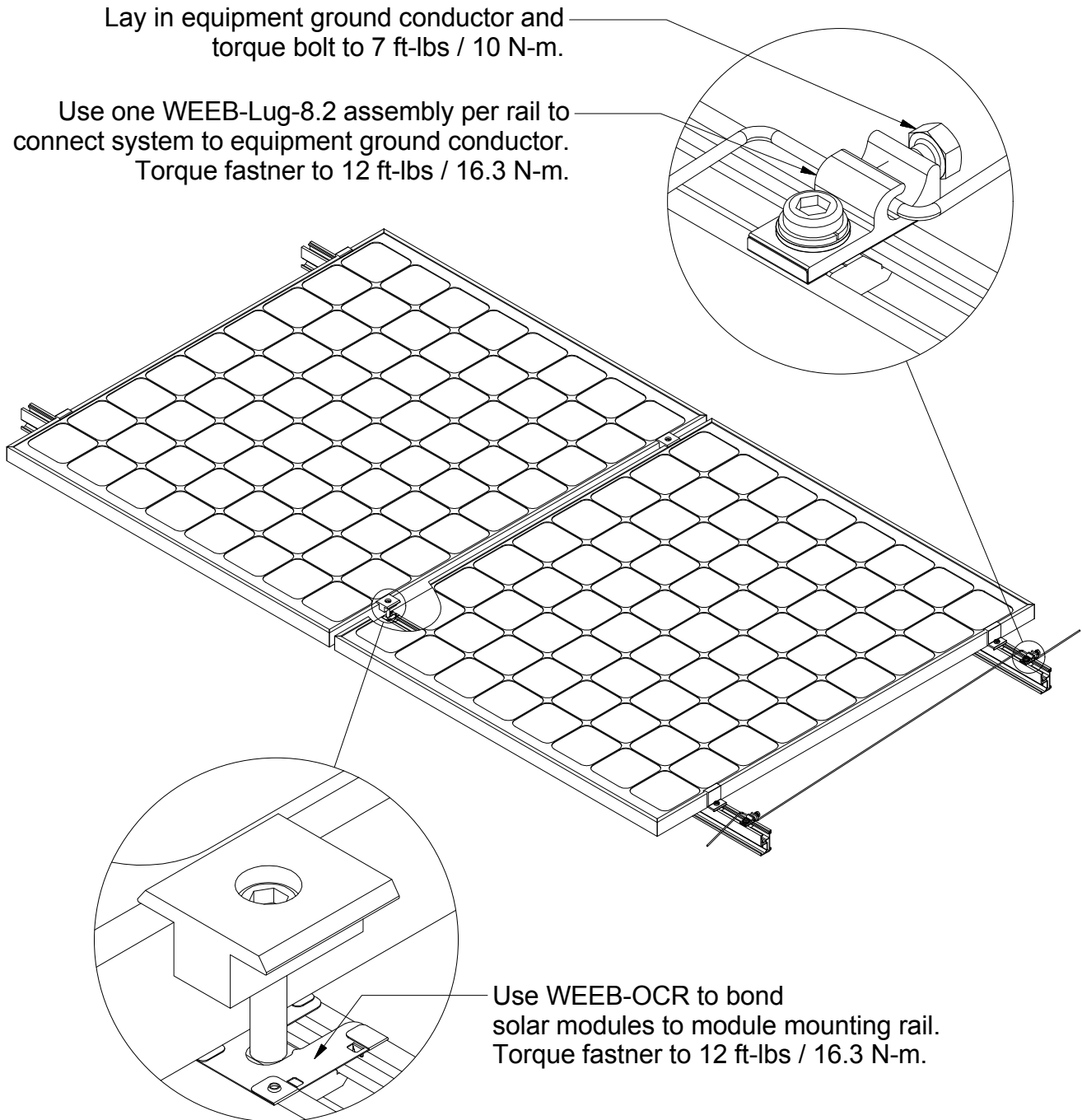

Use WEEB-OCR to bond solar modules to module mounting rail. Torque fastener to 12 ft-lbs / 16.3 N-m.

## Important notes:

1. These installation instructions are identical for both landscape and portrait oriented PV modules. Refer to module's installation instructions for clamping recommendations.
2. Use general purpose anti-seize compound on fastener threads when installing WEEBs.
3. The NEC section 690.43 states "Exposed non-current carrying metal parts of module frames, equipment, and conductor enclosures shall be grounded in accordance with 250.134 or 250.136(A) regardless of voltage".
4. WEEBs are intended for **SINGLE USE ONLY**. Functionality will not be guaranteed if reused.

# WEEB-OCR LAYOUT LANDSCAPE MODULE ORIENTATION

## EVEN NUMBER OF MODULES IN ROW

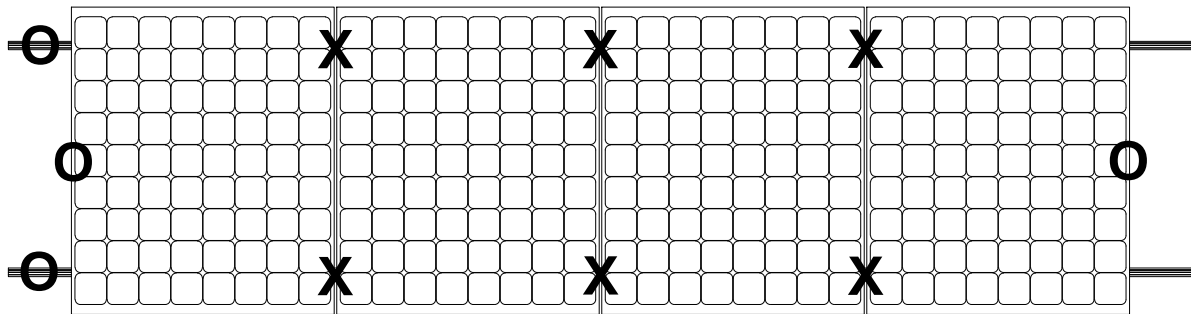

X DENOTES PLACES TO INSTALL WEEB-OCR  
O DENOTES PLACES TO INSTALL WEEB-LUG-8.2

$C \times R = 4 \times 1$

WEEB-OCR NEEDED =  $[(2 \times C) - 2] = [(2 \times 4) - 2] = 6$

## ODD NUMBER OF MODULES IN ROW

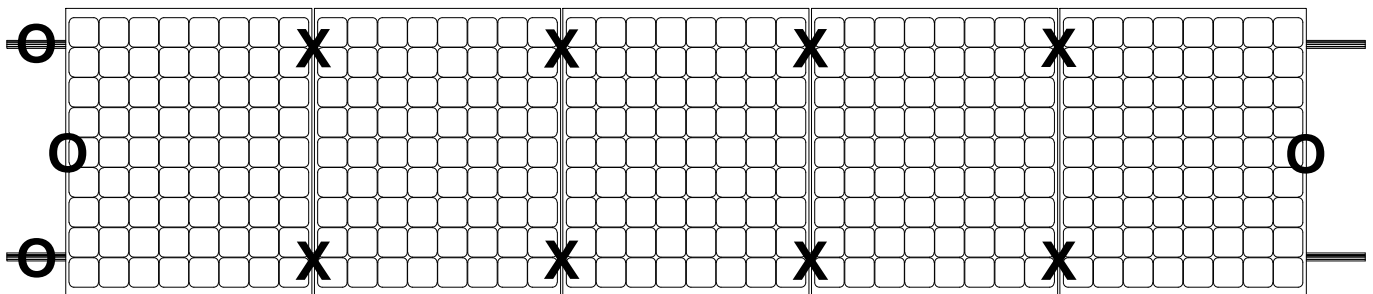

X DENOTES PLACES TO INSTALL WEEB-OCR  
O DENOTES PLACES TO INSTALL WEEB-LUG-8.2

$C \times R = 5 \times 1$

WEEB-OCR NEEDED =  $[(2 \times C) - 2] = [(2 \times 5) - 2] = 8$

### Note:

When replacing a single faulty module, also remove the adjacent module which contacts the same WEEBs as the faulty module. This will ensure that there are never ungrounded modules in the array.

**Customer Service Department**  
7 Aviation Park Drive  
Londonderry, NH 03053  
1-800-346-4175  
1-603-647-5299 (International)