



Washer, Electrical Equipment Bond

WEEB[®] WASHER

INSTALLATION INSTRUCTIONS *For Renusol EW System Only*

Burndy LLC recommends that the sufficient details of the installation be submitted to the AHJ for approval before any work is started.

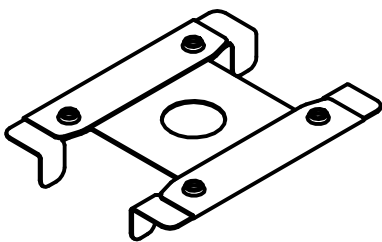

WEEB-CCR

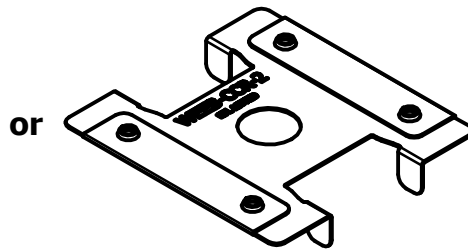

WEEB-CCR-2

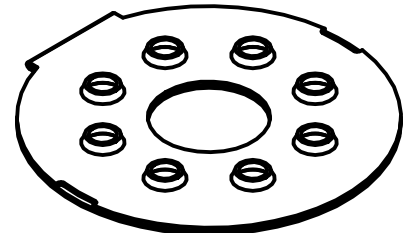

WEEB-DSK516

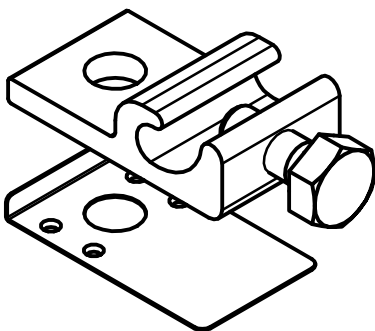

WEEB-LUG-8.0

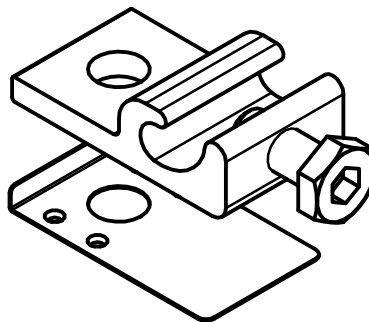

WEEB-LUG-8.0HS

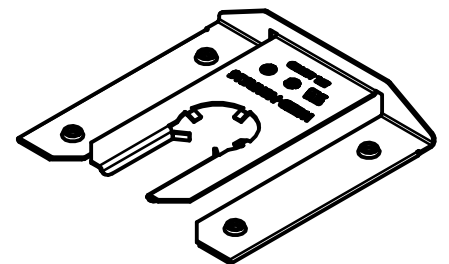

WEEB-MSNR516



Products are tested to UL 467, CAN/CSA-C22.2 No. 41
US/ Canadian standards for safety grounding and bonding equipment.



Intertek
4004188

WEEB[®] WASHER COMPATIBILITY

The WEEB[®] washer family of products can be used to bond anodized aluminum, galvanized steel, steel and other electrically conductive metal structures. All installations shall be in accordance with NEC requirements in the USA and with CSA C22.1 in Canada. The WEEB[®] washers are for use with modules that have a maximum fuse rating of 25A or less.

Certain module frames do not have enough structural strength to withstand the force required to embed a WEEB[®] washer. These frames will deform and therefore not allow sufficient penetration of the WEEB[®] washer teeth. The general requirements for minimum module frame thickness of "C" type module frames are illustrated below. For more information regarding module compatibility, please see the technical documents section of our website.

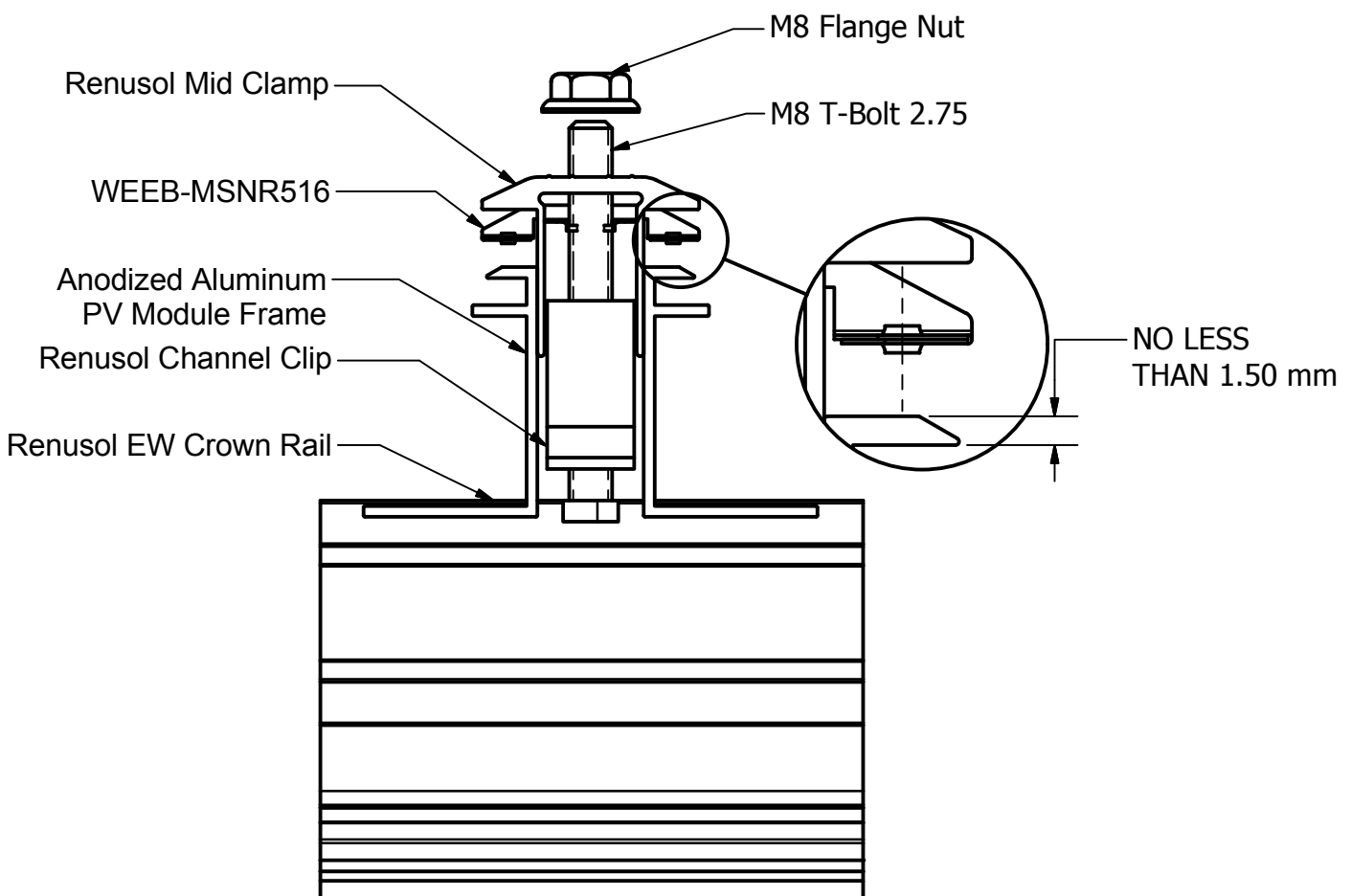

Note:

Inspect each module frame used with a WEEB[®] device to ensure that the bottom mounting face of the frame is flat, and that there are no hindrances to embedding WEEB[®] washer teeth. Do not use a module with a frame that prevents the WEEB[®] washer teeth from embedding fully.

SYSTEM OVERVIEW

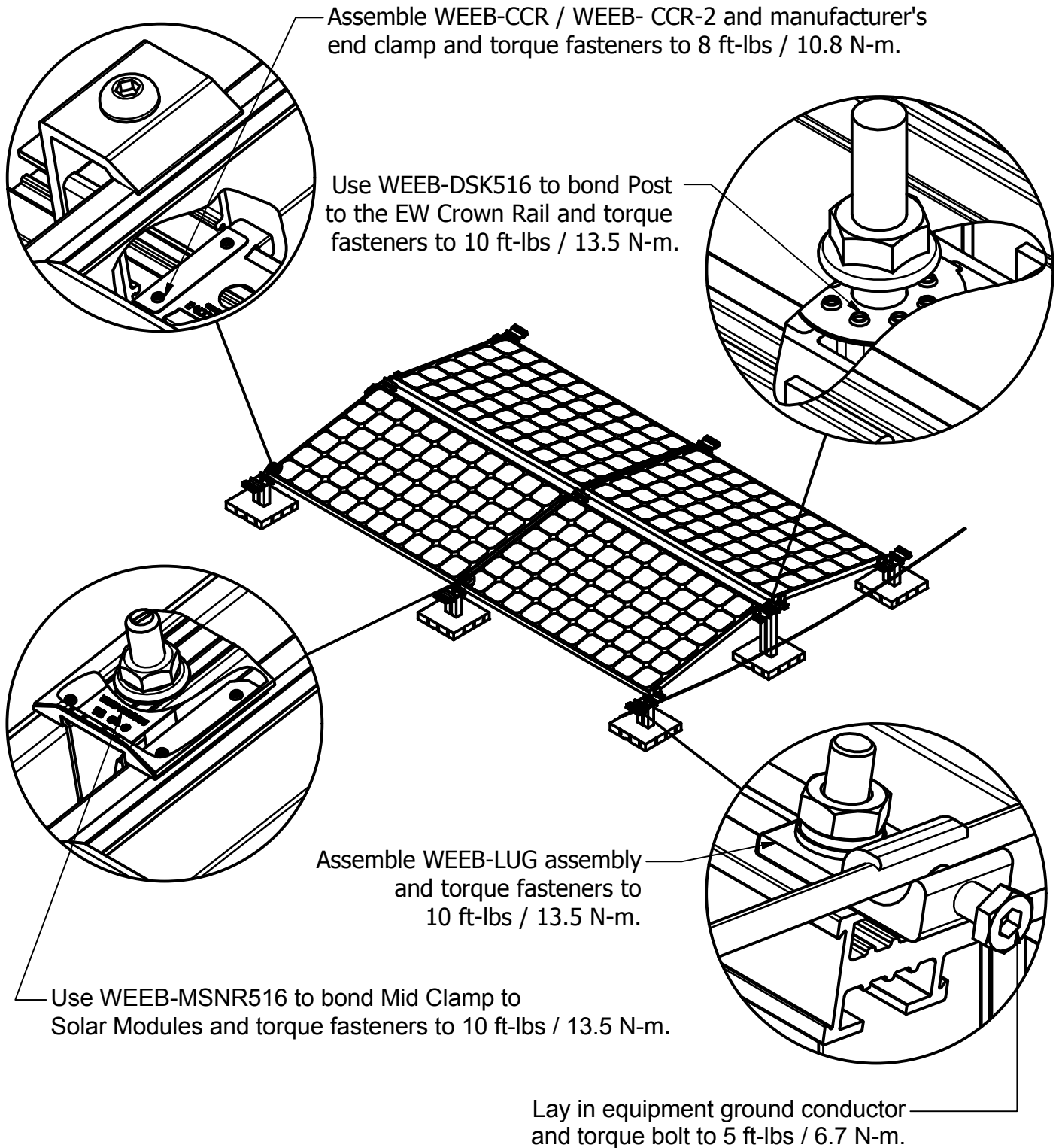

Assemble WEEB-CCR / WEEB-CCR-2 and manufacturer's end clamp and torque fasteners to 8 ft-lbs / 10.8 N-m.

Use WEEB-DSK516 to bond Post to the EW Crown Rail and torque fasteners to 10 ft-lbs / 13.5 N-m.

Assemble WEEB-LUG assembly and torque fasteners to 10 ft-lbs / 13.5 N-m.

Use WEEB-MSNR516 to bond Mid Clamp to Solar Modules and torque fasteners to 10 ft-lbs / 13.5 N-m.

Lay in equipment ground conductor and torque bolt to 5 ft-lbs / 6.7 N-m.

Important notes:

1. Anti-seize or Burndy PENETROX-A is not required on mounting hardware.
2. WEEB® Washers are suitable for multiple use, up to 5 times.
3. The NEC section 690.43 states "Exposed non-current carrying metal parts of module frames, equipment, and conductor enclosures shall be grounded in accordance with 250.134 or 250.136(A) regardless of voltage".
4. WEEB-LUG must be installed parallel to channel as shown.

WEEB-CCR / WEEB-CCR-2, WEEB-DSK516 & WEEB-MSNR516 LAYOUT LANDSCAPE MODULE ORIENTATION

EVEN NUMBER OF MODULES IN ROW

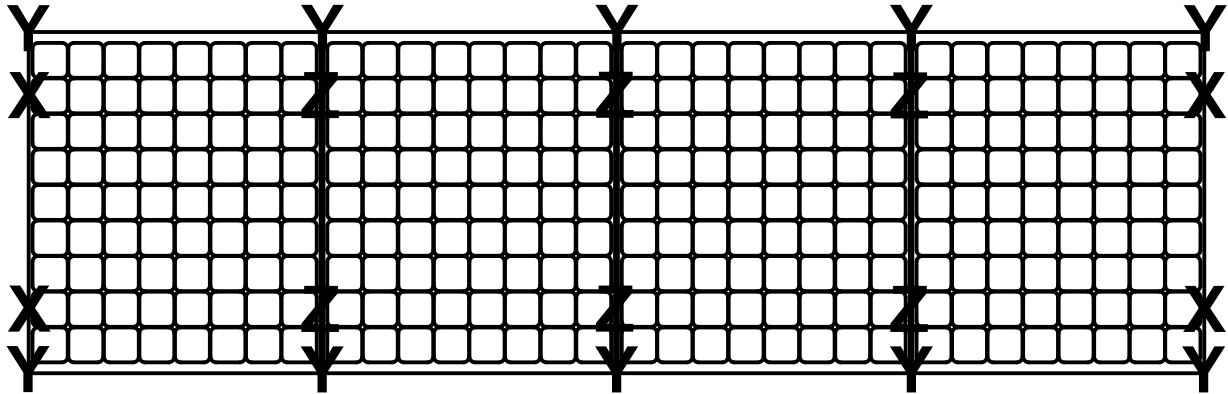

Z DENOTES PLACES TO INSTALL WEEB-MSNR516

$$[2 \times (\text{COLUMN} - 1) \times \text{ROW}] = [2 \times (C - 1) \times R] = [2 \times (4 - 1) \times 1] = 6$$

WEEB-MSNR516 NEEDED = 6

X DENOTES PLACES TO INSTALL WEEB-CCR / WEEB-CCR-2 (AT END CLAMP PLACE)

Y DENOTES PLACES TO INSTALL WEEB-DSK516 (AT EACH POST)

ODD NUMBER OF MODULES IN ROW

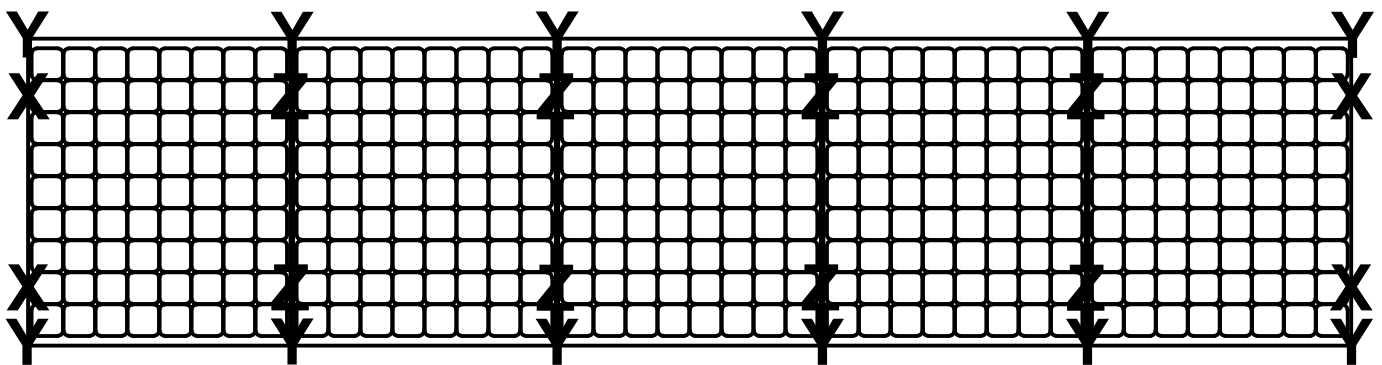

Z DENOTES PLACES TO INSTALL WEEB-MSNR516

$$[2 \times (\text{COLUMN} - 1) \times \text{ROW}] = [2 \times (C - 1) \times R] = [2 \times (5 - 1) \times 1] = 8$$

WEEB-MSNR516 NEEDED = 8

X DENOTES PLACES TO INSTALL WEEB-CCR / WEEB-CCR-2 (AT END CLAMP PLACE)

Y DENOTES PLACES TO INSTALL WEEB-DSK516 (AT EACH POST)

Note:

When replacing a single faulty module, also remove the adjacent module which contacts the same WEEB® washers as the faulty module. This will ensure that there are never ungrounded modules in the array.

EW POST/CROWN WITH WEEB-DSK516 ASSEMBLY

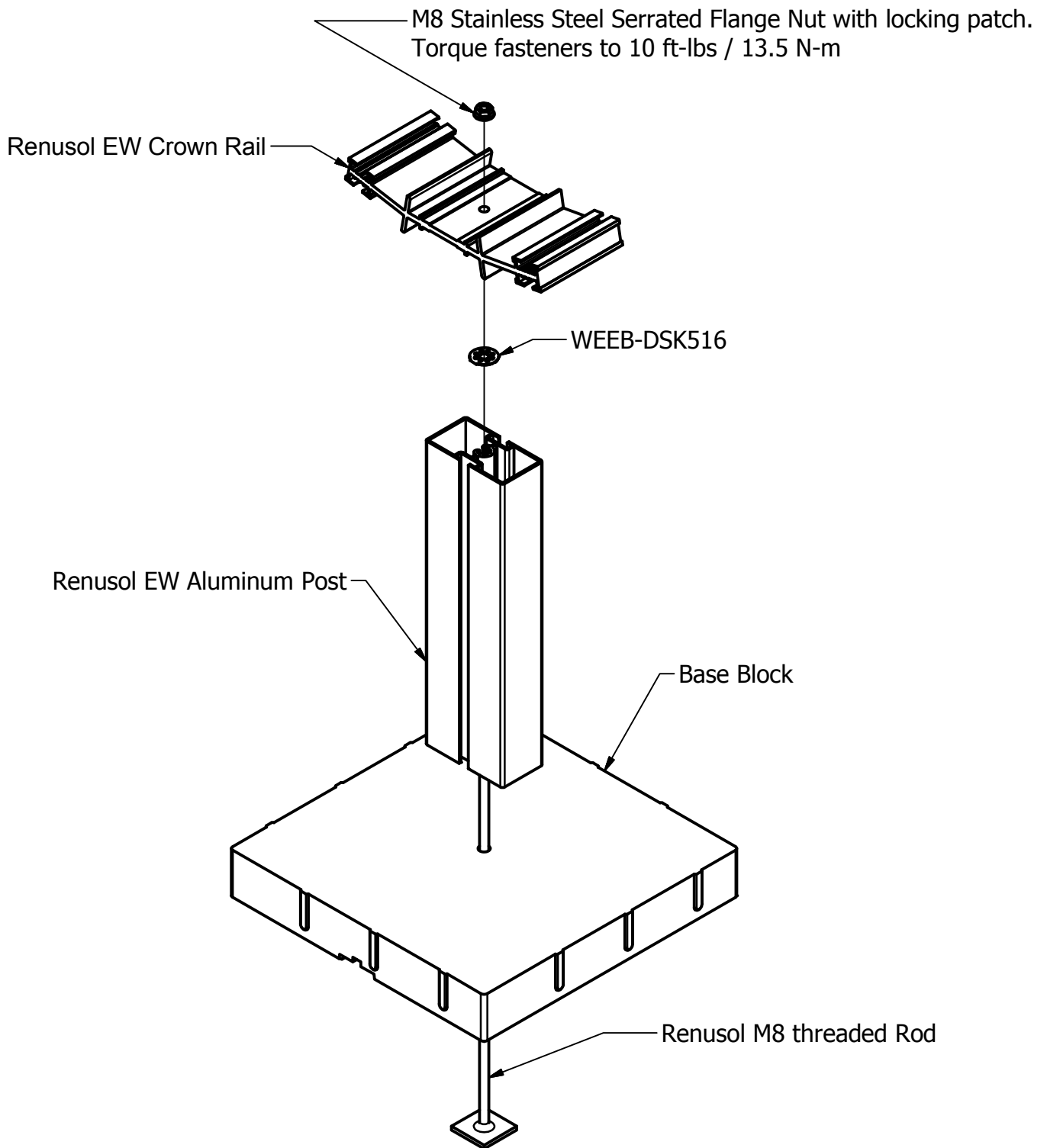

Customer Service Department
7 Aviation Park Drive
Londonderry, NH 03053
1-800-346-4175
1-603-647-5299 (International)