



Washer, Electrical Equipment Bond

WEEB[®] WASHER

INSTALLATION INSTRUCTIONS *For Beacon Car Port System Only*

Burndy LLC recommends that the sufficient details of the installation be submitted to the AHJ for approval before any work is started.

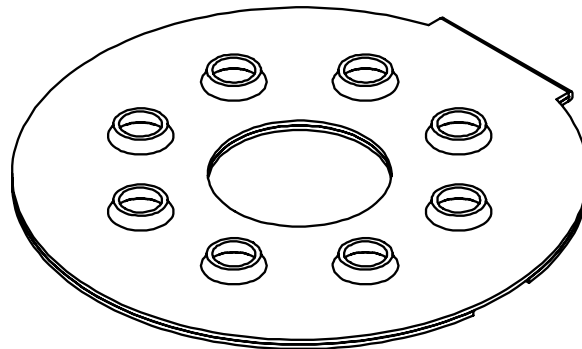

WEEB-DSK516



Products are Listed to UL 467, CSA C22.2 No. 41
US / Canadian standards for safety grounding and bonding equipment.



WEEB-DSK516 COMPATIBILITY

The WEEB® washer family of products can be used to bond anodized aluminum, galvanized steel, steel and other electrically conductive metal structures. All installations shall be in accordance with NEC requirements in the USA and with CSA C22.1 in Canada. The WEEB® washers are for use with modules that have a maximum fuse rating of 25A or less.

Bottom Mounting Modules

The WEEB® washers used for bonding the PV modules to the mounting purlins are compatible with various cross-sections of module frames. The following is an example of a module frame that is compatible. Notice that the WEEB® washer teeth are positioned completely under the edge of the module frame. For more information regarding module compatibility, please see the technical documents section of our website.

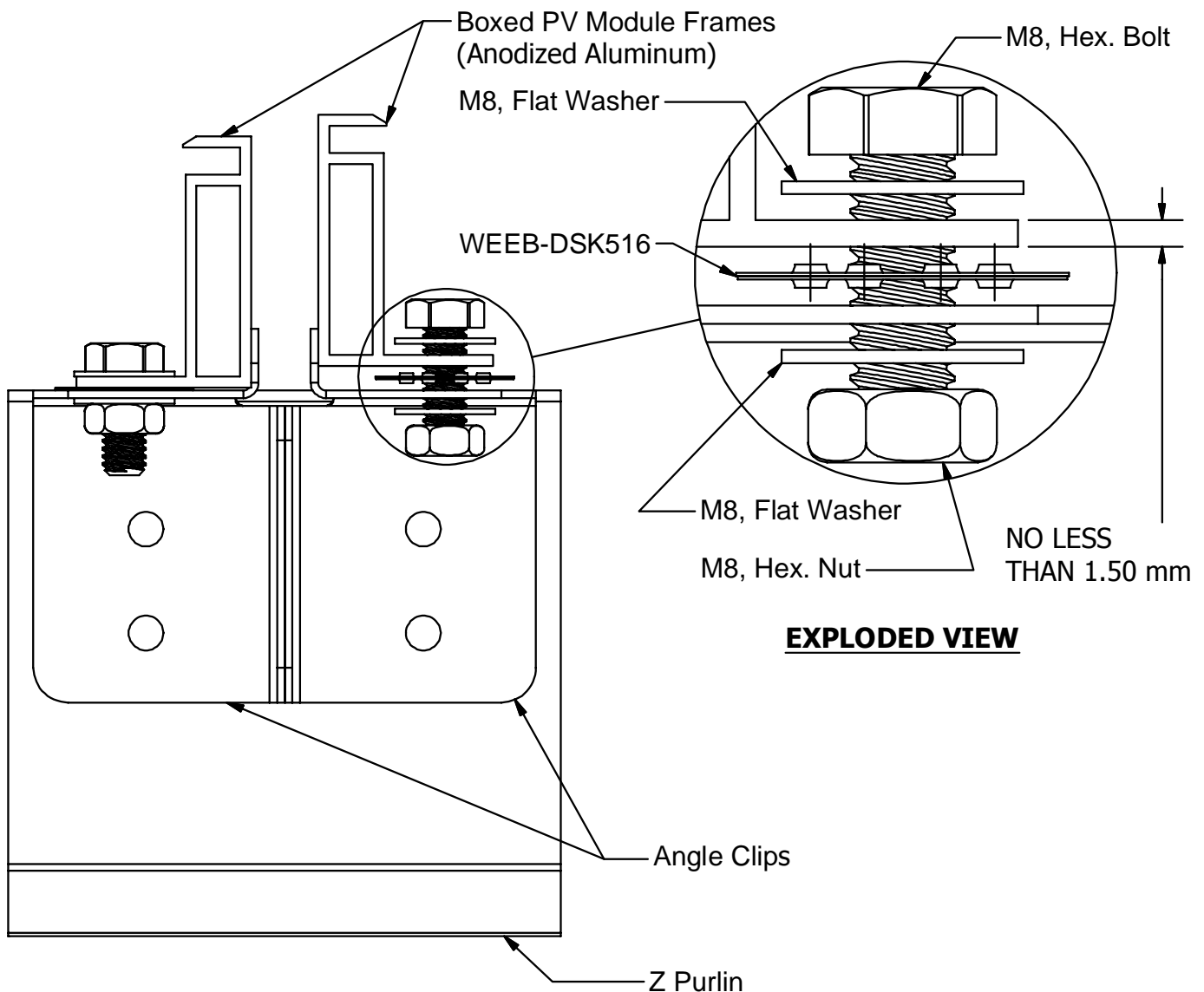

Note:

Inspect each module frame used with a WEEB® device to ensure that the bottom mounting face of the frame is flat, and that there are no hindrances to embedding WEEB® washer teeth. Do not use a module with a frame that prevents the WEEB® washer teeth from embedding fully.

SYSTEM OVERVIEW

Use WEEB-DSK516 to bond solar module frame to module mounting Angle Clip, torque fasteners to a minimum of 8 ft-lbs / 10.83 N-m

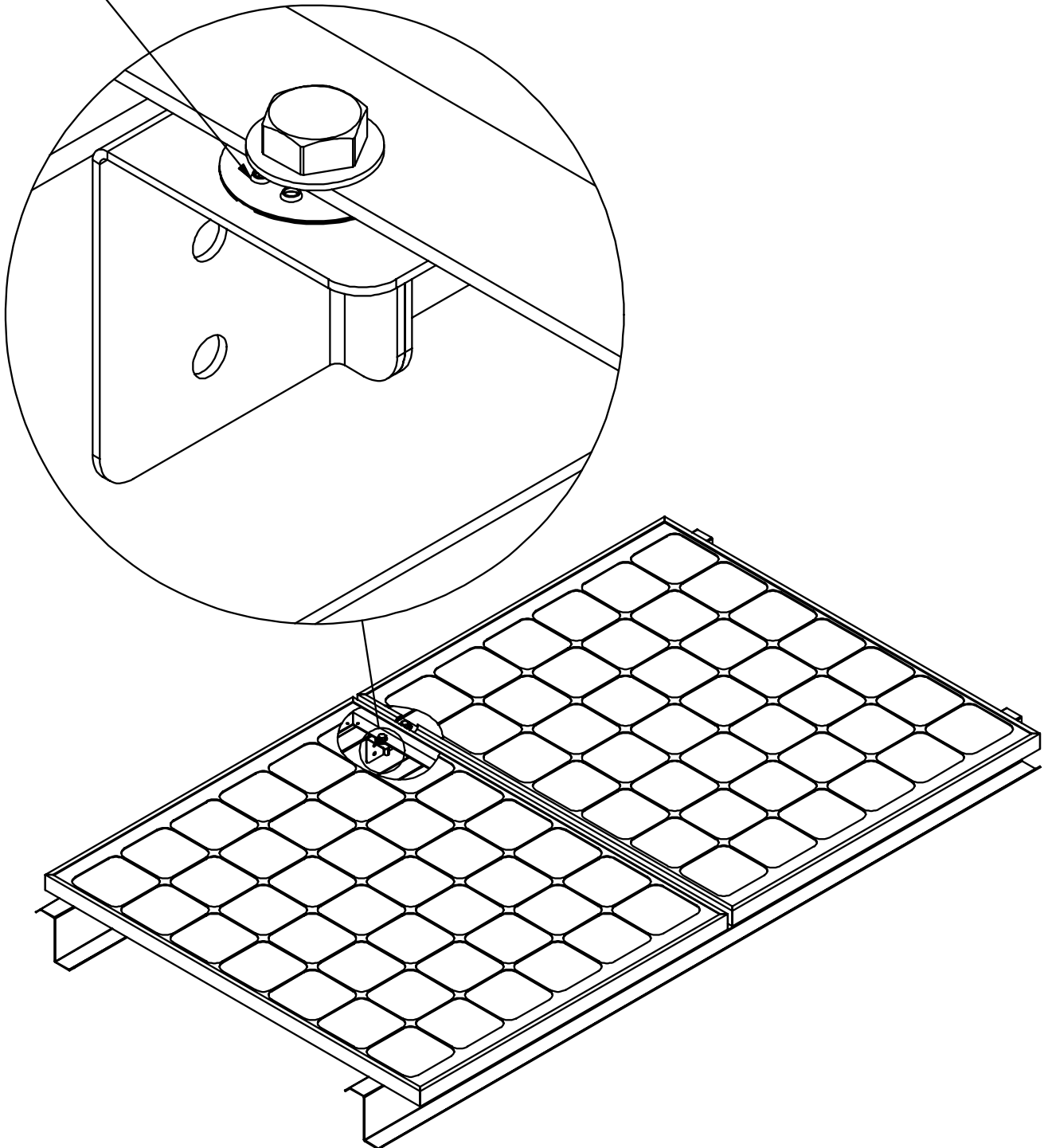

Important notes:

1. The NEC section 690.43 states “Exposed non-current carrying metal parts of module frames, equipment, and conductor enclosures shall be grounded in accordance with 250.134 or 250.136(A) regardless of voltage”.

WEEB[®] WASHER LAYOUT

X DENOTES PLACES TO INSTALL WEEB-DSK516

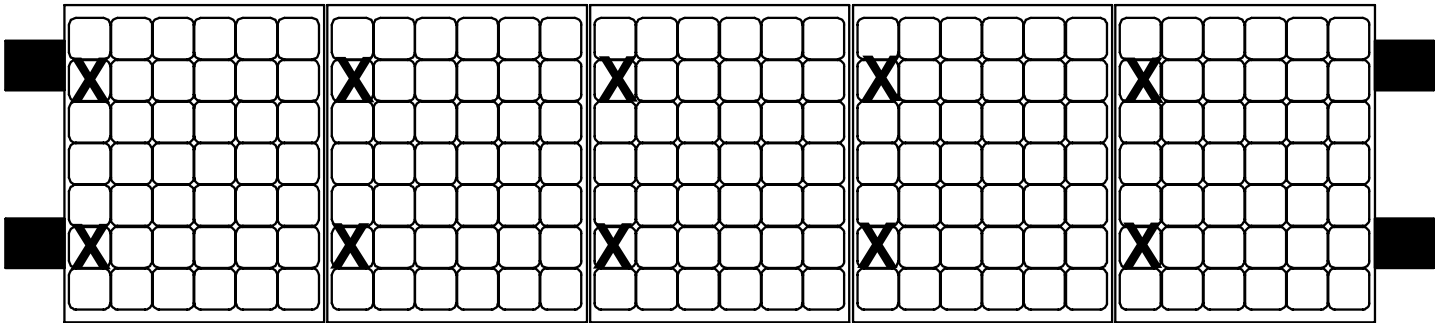

Two WEEB-DSK516's are to be installed for each module

One WEEB-DSK516 should go on each purlin to effectively bond both purlins

Customer Service Department
7 Aviation Park Drive
Londonderry, NH 03053
1-800-346-4175
1-603-647-5299 (International)