

The image features two large, stylized letters, 'G' and 'I', rendered in a vibrant green color. The 'G' is positioned on the left and the 'I' on the right. Behind each letter is a larger, semi-transparent version of the same letter in a lighter shade of green, creating a layered effect. The text 'Acme Transformer General Information' is written in a black, elegant serif font, oriented vertically and centered between the two letters.

*Acme Transformer General Information*

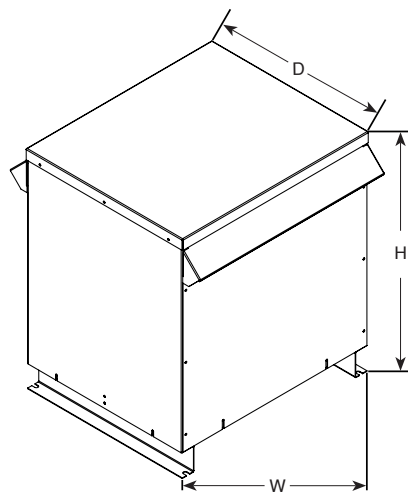

*Section*



**Design Figures, Wiring Diagrams, Accessories,  
Specification Guides, Industry Standards and  
Alphanumerical Catalog Number Index**

Design Figures	208
Wiring Diagrams	209-216
Transformer Accessories	217-218
Acme Specifications Guide	219-223
Industry Standards Data	224-225
Alphanumerical Catalog Number Listing	226-233
Product Warranty & Shielding Information	Inside Back Cover

**DESIGN FIGURES - Section 1, 2, 3, 4 and 5**

These drawings are for reference only. Contact factory for certified drawings.

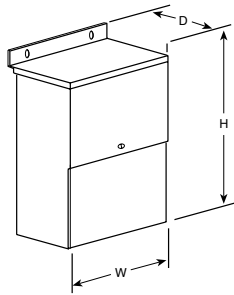

**Design A**

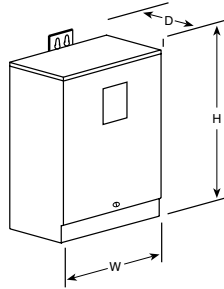

**Design B**

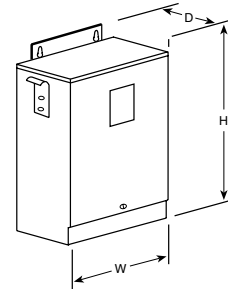

**Design C**

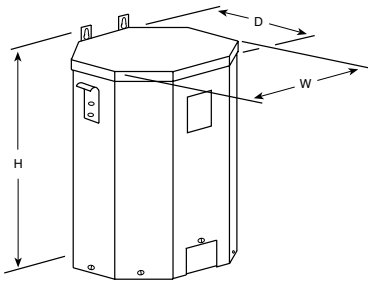

**Design D**

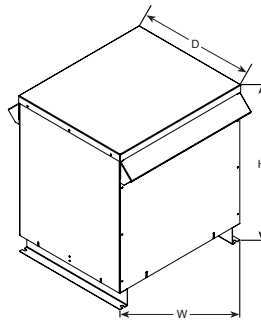

**Design E**

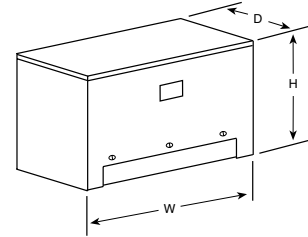

**Design F**

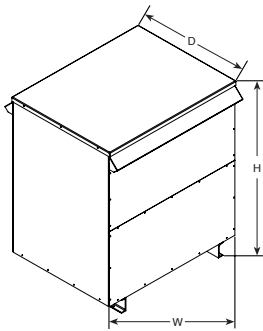

**Design G**

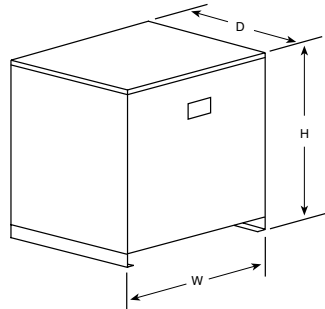

**Design H**

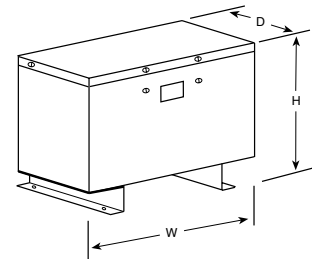

**Design I**

Wiring Diagrams - Section 1, 2, 3, 4 and 5

**1** PRIMARY: 240 X 480  
SECONDARY: 120/240  
TAPS: None

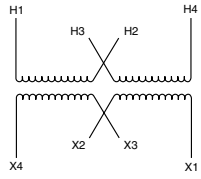

Primary Volts	Connect Primary Lines To	Inter-Connect	Connect Secondary Lines To
480	H1-H4	H2 to H3	
240	H1-H3 & H2-H4		

**Secondary Volts**

240		X2 to X3	X1-X4
120/240		X2 to X3	X1-X2-X4
120		X1 to X3 X2 to X4	X1-X4

**2** PRIMARY: 240 X 480  
SECONDARY: 120/240  
TAPS: None

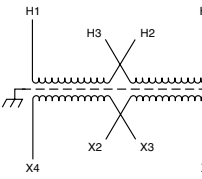

Primary Volts	Connect Primary Lines To	Inter-Connect	Connect Secondary Lines To
480	H1-H4	H2 to H3	
240	H1-H3 & H2-H4		

**Secondary Volts**

240		X2 to X3	X1-X4
120/240		X2 to X3	X1-X2-X4
120		X1 to X3 X2 to X4	X1-X4

**3** PRIMARY: 240 X 480  
SECONDARY: 120/240  
TAPS: 2, 2 1/2% ANFC, 2, 2 1/2% BNFC

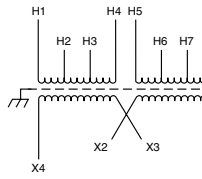

Primary Volts	Connect Primary Lines To	Inter-Connect	Connect Secondary Lines To
252	H1-H8	H1 to H5 H4 to H8	
240	H1-H7	H1 to H5 H3 to H7	
228	H1-H6	H1 to H5 H2 to H6	
504	H1-H8	H4 to H5	
492	H1-H8	H3 to H5	
480	H1-H7	H3 to H5	
468	H1-H7	H2 to H5	
456	H1-H6	H2 to H5	

**Secondary Volts**

240		X2 to X3	X1-X4
120/240		X2 to X3	X1-X2-X4
120		X1 to X3 X2 to X4	X1-X4

**4** PRIMARY: 240 X 480  
SECONDARY: 120/240  
2, 2 1/2% ANFC, 4, 2 1/2% BNFC

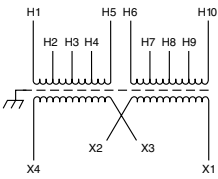

Primary Volts	Connect Primary Lines To	Inter-Connect	Connect Secondary Lines To
216	H1-H10	H1 to H9 H10 to H2	
228	H1-H10	H1 to H8 H10 to H3	
240	H1-H10	H1 to H7 H10 to H4	
252	H1-H10	H1 to H6 H10 to H5	
432	H1-H10	H2 to H9	
444	H1-H10	H3 to H9	
456	H1-H10	H3 to H8	
468	H1-H10	H4 to H8	
480	H1-H10	H4 to H7	
492	H1-H10	H5 to H7	
504	H1-H10	H5 to H6	

**Secondary Volts**

240		X2 to X3	X1-X4
120/240		X2 to X3	X1-X3-X4
120		X1 to X3 X2 to X4	X1-X4

**5** PRIMARY: 240 X 480  
SECONDARY: 120/240  
TAPS: 2, 2 1/2% ANFC, 2, 2 1/2% BNFC

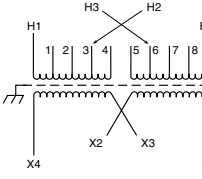

Primary Volts	Connect Primary Lines To	Inter-Connect	Connect Secondary Lines To
216	H1-H4	H1, H3, 8 & H2, H4, 1	
228	H1-H4	H1, H3, 7 & H2, H4, 2	
240	H1-H4	H1, H3, 6 & H2, H4, 3	
252	H1-H4	H1, H3, 5 & H2, H4, 4	
432	H1-H4	H2, 1 & H3, 8	
444	H1-H4	H2, 2 & H3, 8	
456	H1-H4	H2, 2 & H3, 7	
468	H1-H4	H2, 3 & H3, 7	
480	H1-H4	H2, 3 & H3, 6	
492	H1-H4	H2, 4 & H3, 6	
504	H1-H4	H2, 4 & H3, 5	

**Secondary Volts**

240		X2 to X3	X1-X4
120/240		X2 to X3	X1-X2-X4
120		X1 to X3 X2 to X4	X1-X4

**8** PRIMARY: 600  
SECONDARY: 120/240  
TAPS: None

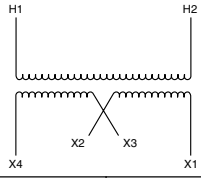

Primary Volts	Connect Primary Lines To	Inter-Connect	Connect Secondary Lines To
600	H1-H2		

**Secondary Volts**

240		X2 to X3	X1-X4
120/240		X2 to X3	X1-X2-X4
120		X1 to X3 X2 to X4	X1-X4

**9** PRIMARY: 600  
SECONDARY: 120/240  
TAPS: None

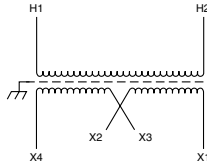

Primary Volts	Connect Primary Lines To	Inter-Connect	Connect Secondary Lines To
600	H1-H2		
<b>Secondary Volts</b>			
240		X2 to X3	X1-X4
120/240		X2 to X3	X1-X2-X4
120		X1 to X3 X2 to X4	X1-X4

**12** PRIMARY: 240  
SECONDARY: 120/240  
TAPS: None

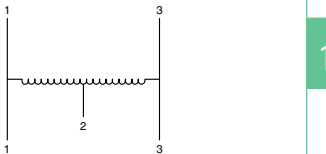

Primary Volts	Connect Primary Lines To	Inter-Connect	Connect Secondary Lines To
240	1-3		
<b>Secondary Volts</b>			
240			1-3
120			1-2 or 2-3
120/240			1-2-3

**17** PRIMARY: 208 Volts  
SECONDARY: 120/240 Volts  
TAPS:

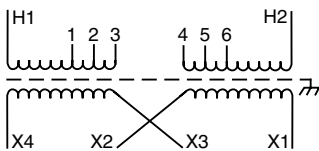

Primary Volts	Connect Primary Lines To	Inter-Connect	Connect Secondary Lines To
218	H1 & H2	3 to 4	
213	H1 & H2	2 to 4	
208	H1 & H2	3 to 5	
203	H1 & H2	2 to 5	
198	H1 & H2	1 to 5	
192	H1 & H2	2 to 6	
187	H1 & H2	1 to 6	
<b>Secondary Volts</b>			
240		X2 to X3	X1-X4
120/240		X2 to X3	X1-X2-X4
120		X1 to X3 X2 to X4	X1-X4

**10** PRIMARY: 600  
SECONDARY: 120/240  
TAPS: 2, 5% BNFC

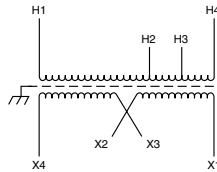

Primary Volts	Connect Primary Lines To	Inter-Connect	Connect Secondary Lines To
600	H1-H4		
570	H1-H3		
540	H1-H2		
<b>Secondary Volts</b>			
240		X2 to X3	X1-X4
120/240		X2 to X3	X1-X2-X4
120		X1 to X3 X2 to X4	X1-X4

**14** EXPORT MODEL  
PRIMARY: 190-220 x 380-440  
SECONDARY: 120/240

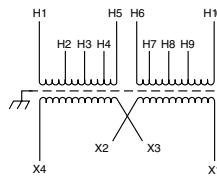

Primary Volts	Connect Primary Lines To	Inter-Connect	Connect Secondary Lines To
190	H1 & H7	H1 to H6 H2 to H7	
200	H1 & H8	H1 to H6 H3 to H8	
208	H1 & H9	H1 to H6 H4 to H9	
220	H1 & H10	H1 to H6 H5 to H10	
380	H1 & H7	H2 & H6	
400	H1 & H8	H3 & H6	
416	H1 & H9	H4 & H6	
440	H1 & H10	H5 & H6	
<b>Secondary Volts</b>			
240		X2 to X3	X1-X4
120/240		X2 to X3	X1-X2-X4
120		X1 to X3 X2 to X4	X1-X4

**11** PRIMARY: 600  
SECONDARY: 120/240  
TAPS: 2, 2 1/2% ANFC, 4, 2 1/2% BNFC

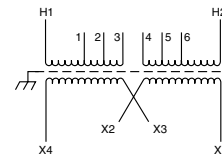

Primary Volts	Connect Primary Lines To	Inter-Connect	Connect Secondary Lines To
540	H1-H2	1-6	
555	H1-H2	1-5	
570	H1-H2	2-6	
585	H1-H2	2-5	
600	H1-H2	3-5	
615	H1-H2	2-4	
635	H1-H2	3-4	
<b>Secondary Volts</b>			
240		X2 to X3	X1-X4
120/240		X2 to X3	X1-X2-X4
120		X1 to X3 X2 to X4	X1-X4

**16** POWER LINE CONDITIONER

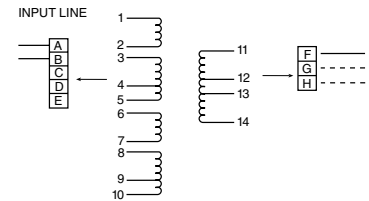

Input Connections		Insulate & Insulate
Volts	Connect	
120	1, 3, 6, 8 to A 2, 5, 7, 10 to B	4, 9
208	1, 6 to A 4, 9 to B 2, 3 to C 7, 8 to D	5, 10
240	1, 6 to A 5, 10 to B 2, 3 to C 7, 8 to D	4, 9
480	1 to A 10 to B 2, 3 to C 5, 6 to D 7, 8 to E	4, 9
Output Connections		
Output Volts	Connect	Lines To
120	11 to F 12 to G 14 to H	F, G
120/240	11 to F 12 to G 14 to H	F, G, H
208	11 to F 12 to G 13 to H	F, H
240	11 to F 12 to G 14 to H	F, H

**NOTE:** To prevent externally shorting, all leads marked "INSULATE" must be individually capped with wire nuts or equivalent. Insulate leads individually!

**18** PRIMARY: 240 Volts Delta  
SECONDARY: 208Y/120 Volts  
TAPS: 2, 5% BNFC

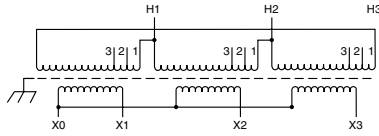

Primary Volts	Connect Primary Lines To	Inter-Connect	Connect Secondary Lines To
240	H1, H2, H3	1	
228	H1, H2, H3	2	
216	H1, H2, H3	3	

**Secondary Volts**

208			X1, X2, X3
120 1 phase			X1 to X0 X2 to X0 X3 to X0

**21** PRIMARY: 480 Volts Delta  
SECONDARY: 208Y/120 Volts  
TAPS: 2, 5% BNFC

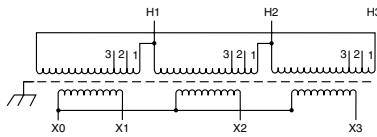

Primary Volts	Connect Primary Lines To	Inter-Connect	Connect Secondary Lines To
480	H1, H2, H3	1	
456	H1, H2, H3	2	
432	H1, H2, H3	3	

**Secondary Volts**

208			X1, X2, X3
120 1 phase			X1 to X0 X2 to X0 X3 to X0

**24** PRIMARY: 380 Volts Delta  
SECONDARY: 220Y/127 Volts  
TAPS: 2, 5% BNFC

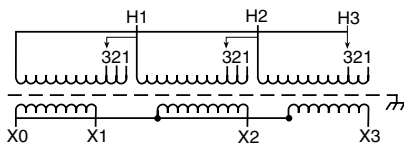

Primary Volts	Connect Primary Lines To	Inter-Connect	Connect Secondary Lines To
380	H1, H2, H3	1	
361	H1, H2, H3	2	
342	H1, H2, H3	3	

**Secondary Volts**

220			X1, X2, X3
127 1 phase			X1 to X0 X2 to X0 X3 to X0

**19** PRIMARY: 240 Volts Delta  
SECONDARY: 208Y/120 Volts  
TAPS: 2, 2 1/2% ANFC, 2, 2 1/2% BNFC

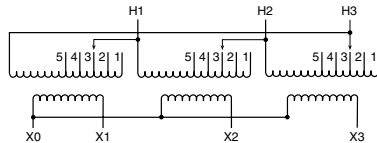

Primary Volts	Connect Primary Lines To	Inter-Connect	Connect Secondary Lines To
252	H1, H2, H3	1	
246	H1, H2, H3	2	
240	H1, H2, H3	3	
234	H1, H2, H3	4	
228	H1, H2, H3	5	

**Secondary Volts**

208			X1, X2, X3
120 1 phase			X1 to X0 X2 to X0 X3 to X0

**22** PRIMARY: 480 Volts Delta  
SECONDARY: 208Y/120 Volts  
TAPS: 2, 2 1/2% ANFC, 4, 2 1/2% BNFC

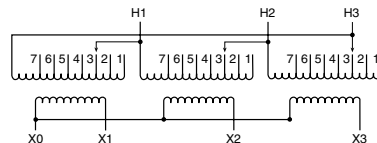

Primary Volts	Connect Primary Lines To	Inter-Connect	Connect Secondary Lines To
504	H1, H2, H3	1	
492	H1, H2, H3	2	
480	H1, H2, H3	3	
468	H1, H2, H3	4	
456	H1, H2, H3	5	
444	H1, H2, H3	6	
432	H1, H2, H3	7	

**Secondary Volts**

208			X1, X2, X3
120 1 phase			X1 to X0 X2 to X0 X3 to X0

**25** PRIMARY: 480 Volts Delta  
SECONDARY: 240 Volts Delta/120 Volts  
TAPS: 2, 5% BNFC

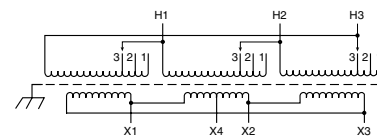

Primary Volts	Connect Primary Lines To	Inter-Connect	Connect Secondary Lines To
480	H1, H2, H3	1	
456	H1, H2, H3	2	
432	H1, H2, H3	3	

**Secondary Volts**

240			X1, X2, X3
120			X1, X4 or X2, X4

**20** PRIMARY: 380 Volts Delta  
SECONDARY: 220Y/127 Volts  
TAPS: 2, 2 1/2% ANFC, 4, 2 1/2% BNFC

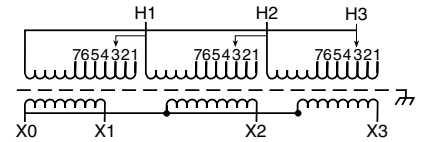

Primary Volts	Connect Primary Lines To	Inter-Connect	Connect Secondary Lines To
399	H1, H2, H3	1	
390	H1, H2, H3	2	
380	H1, H2, H3	3	
371	H1, H2, H3	4	
361	H1, H2, H3	5	
352	H1, H2, H3	6	
342	H1, H2, H3	7	

**Secondary Volts**

220			X1, X2, X3
127 1 phase			X1 to X0 X2 to X0 X3 to X0

**23** PRIMARY: 120/208/240/277 Volts  
SECONDARY: 120/240 Volts

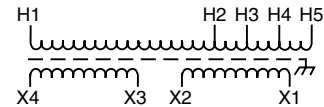

Primary Volts	Connect Primary Lines To	Inter-Connect	Connect Secondary Lines To
277	H1, H5		
240	H1, H4		
208	H1, H3		
120	H1, H2		

**Secondary Volts**

120		X1 to X3 X2 to X4	X1-X4
120/240		X2 to X3	X1-X2-X4
240		X2 to X3	X1-X4

**26** PRIMARY: 480 Volts Delta  
SECONDARY: 240 Volts Delta/120 Volts  
TAPS: 2, 2 1/2% ANFC, 4, 2 1/2% BNFC

Primary Volts	Connect Primary Lines To	Inter-Connect	Connect Secondary Lines To
504	H1, H2, H3	1	
492	H1, H2, H3	2	
480	H1, H2, H3	3	
468	H1, H2, H3	4	
456	H1, H2, H3	5	
444	H1, H2, H3	6	
432	H1, H2, H3	7	
<b>Secondary Volts</b>			
240			X1, X2, X3
120			X1, X4 or X2, X4

**31** PRIMARY: 480 Volts Delta  
SECONDARY: 480Y/277 Volts  
TAPS: 2, 2 1/2% ANFC, 4, 2 1/2% BNFC

Primary Volts	Connect Primary Lines To	Inter-Connect	Connect Secondary Lines To
504	H1, H2, H3	1	
492	H1, H2, H3	2	
480	H1, H2, H3	3	
468	H1, H2, H3	4	
456	H1, H2, H3	5	
444	H1, H2, H3	6	
432	H1, H2, H3	7	
<b>Secondary Volts</b>			
480			X1, X2, X3
277 1 phase			X1 to X0 X2 to X0 X3 to X0

**28** PRIMARY: 600 Volts Delta  
SECONDARY: 208Y/120 Volts  
TAPS: 2, 5% BNFC

Primary Volts	Connect Primary Lines To	Inter-Connect	Connect Secondary Lines To
600	H1, H2, H3	1	
570	H1, H2, H3	2	
540	H1, H2, H3	3	
<b>Secondary Volts</b>			
208			X1, X2, X3
120 1 phase			X1 to X0 X2 to X0 X3 to X0

**32** PRIMARY: 480 Volts Delta  
SECONDARY: 480Y/277 Volts  
TAPS: 2, 2 1/2% ANFC, 4, 2 1/2% BNFC

Primary Volts	Connect Primary Lines To	Inter-Connect	Connect Secondary Lines To
504	H1, H2, H3	1 to 2	
492	H1, H2, H3	2 to 3	
480	H1, H2, H3	1 to 4	
468	H1, H2, H3	3 to 4	
456	H1, H2, H3	1 to 6	
444	H1, H2, H3	3 to 6	
432	H1, H2, H3	5 to 6	
<b>Secondary Volts</b>			
480			X1, X2, X3
277 1 phase			X1 to X0 X2 to X0 X3 to X0

**35** PRIMARY: 460 Volts Delta  
SECONDARY: 460Y/266 Volts  
TAPS: 2-2 1/2% ANFC and BNFC

Primary Volts	%	Connect Leads to Tap No.
483	105	1
472	102.5	2
460	100	3
449	97.5	4
437	95	5
<b>Secondary Volts</b>		
460		X1, X2, X3
266 1 phase		X1 & X0 X2 & X0 X3 & X0

**29** PRIMARY: 600 Volts Delta  
SECONDARY: 208Y/120 Volts  
TAPS: 2, 2 1/2% ANFC, 4, 2 1/2% BNFC

Primary Volts	Connect Primary Lines To	Inter-Connect	Connect Secondary Lines To
630	H1, H2, H3	1	
615	H1, H2, H3	2	
600	H1, H2, H3	3	
585	H1, H2, H3	4	
570	H1, H2, H3	5	
555	H1, H2, H3	6	
540	H1, H2, H3	7	
<b>Secondary Volts</b>			
208			X1, X2, X3
120 1 phase			X1 to X0 X2 to X0 X3 to X0

**34** PRIMARY: 460 Volts Delta  
SECONDARY: 460Y/266 Volts  
TAPS: 1-5% ANFC and BNFC

Primary Volts	%	Connect Leads to Tap No.
483	105	1
460	100	2
437	95	3
<b>Secondary Volts</b>		
460		X1, X2, X3
266 1 phase		X1 & X0 X2 & X0 X3 & X0

**37** PRIMARY: 460 Volts Delta  
SECONDARY: 230Y/133 Volts  
TAPS: 1-5% ANFC and BNFC

Primary Volts	%	Connect Leads to Tap No.
483	105	1
460	100	2
437	95	3
<b>Secondary Volts</b>		
230		X1, X2, X3
133 1 phase		X1 & X0 X2 & X0 X3 & X0

**38** PRIMARY: 460 Volts Delta  
SECONDARY: 230Y/133 Volts  
TAPS: 2-2 1/2% ANFC and BNFC

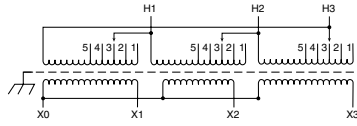

Primary Volts	%	Connect Leads to Tap No.
483	105	1
472	102.5	2
460	100	3
449	97.5	4
437	95	5

Secondary Volts		
230		X1, X2, X3
133 1 phase		X1 & X0 X2 & X0 X3 & X0

**40** PRIMARY: 575 Volts Delta  
SECONDARY: 230Y/133 Volts  
TAPS: 1-5% ANFC and BNFC

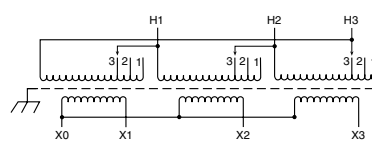

Primary Volts	%	Connect Leads to Tap No.
604	105	1
575	100	2
546	95	3

Secondary Volts		
230		X1, X2, X3
133 1 phase		X1 & X0 X2 & X0 X3 & X0

**41** PRIMARY: 575 Volts Delta  
SECONDARY: 230Y/133 Volts  
TAPS: 2-2 1/2% ANFC and BNFC

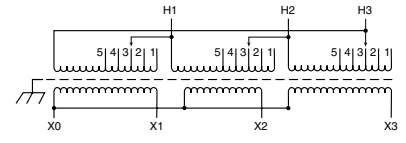

Primary Volts	%	Connect Leads to Tap No.
604	105	1
589	102.5	2
575	100	3
561	97.5	4
546	95	5

Secondary Volts		
230		X1, X2, X3
133 1 phase		X1 & X0 X2 & X0 X3 & X0

**43** PRIMARY: 575 Volts Delta  
SECONDARY: 460Y/266 Volts  
TAPS: 1-5% ANFC and BNFC

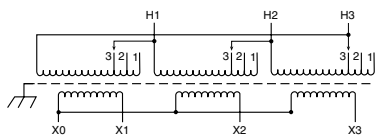

Primary Volts	%	Connect Leads to Tap No.
604	105	1
575	100	2
546	95	3

Secondary Volts		
460		X1, X2, X3
266 1 phase		X1 & X0 X2 & X0 X3 & X0

**44** PRIMARY: 575 Volts Delta  
SECONDARY: 460Y/266 Volts  
TAPS: 2-2 1/2% ANFC and BNFC

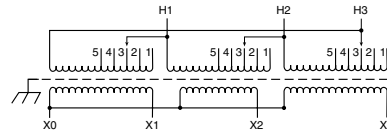

Primary Volts	%	Connect Leads to Tap No.
604	105	1
589	102.5	2
575	100	3
561	97.5	4
546	95	5

Secondary Volts		
460		X1, X2, X3
266 1 phase		X1 & X0 X2 & X0 X3 & X0

**46** PRIMARY: 208 Volts Delta  
SECONDARY: 480Y/277 Volts  
TAPS: 2, 2 1/2% ANFC, 2, 2 1/2% BNFC

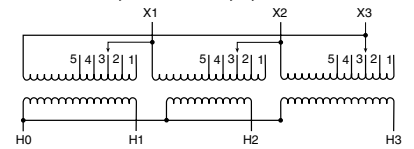

Primary Volts	Connect Primary Lines To	Inter-Connect	Connect Secondary Lines To
218	X1, X2, X3	1	
213	X1, X2, X3	2	
208	X1, X2, X3	3	
203	X1, X2, X3	4	
198	X1, X2, X3	5	

Secondary Volts			
480			H1, H2, H3
277 1 phase			H1 to H0 H2 to H0 H3 to H0

**48** PRIMARY: 208 Volts Delta  
SECONDARY: 480Y/277 Volts  
TAPS: 2, 5% BNFC

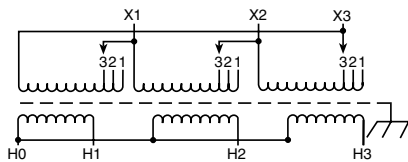

Primary Volts	Connect Primary Lines To	Inter-Connect	Connect Secondary Lines To
208	X1, X2, X3	1	
198	X1, X2, X3	2	
187	X1, X2, X3	3	

Secondary Volts			
480			H1, H2, H3
277 1 phase			H1 to H0 H2 to H0 H3 to H0

**51** PRIMARY: 600 Volts Delta  
SECONDARY: 480Y/277 Volts  
TAPS: 2, 2 1/2% ANFC, 4, 2 1/2% BNFC

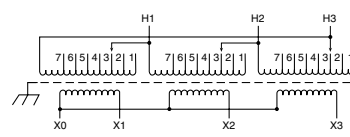

Primary Volts	Connect Primary Lines To	Inter-Connect	Connect Secondary Lines To
630	H1, H2, H3	1	
615	H1, H2, H3	2	
600	H1, H2, H3	3	
585	H1, H2, H3	4	
570	H1, H2, H3	5	
555	H1, H2, H3	6	
540	H1, H2, H3	7	

Secondary Volts			
480			X1, X2, X3
277 1 phase			X1 to X0 X2 to X0 X3 to X0

**55** PRIMARY: 600 Volts Delta  
SECONDARY: 480Y/277 Volts  
TAPS: 2, 5% BNFC

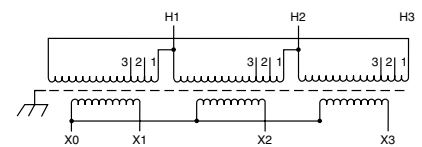

Primary Volts	Connect Primary Lines To	Inter-Connect	Connect Secondary Lines To
600	H1, H2, H3	1	
570	H1, H2, H3	2	
540	H1, H2, H3	3	

Secondary Volts			
480			X1, X2, X3
277 1 phase			X1 to X0 X2 to X0 X3 to X0



**56** PRIMARY: 600 Volts  
SECONDARY: 480 Volts  
TAPS: 2, 5% BNFC

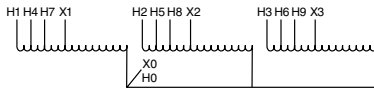

Primary Volts	Alt Rating	Connect Primary Lines To	Inter-Connect	Connect Secondary Lines To
600	480	H1, H2, H3		
570	456	H4, H5, H6		
540	432	H7, H8, H9		
Secondary Volts				
480	380			X1, X2, X3
277 1 phase	220 1 phase			X1 to X0 X2 to X0 X3 to X0

**59** PRIMARY: 230 Volts Delta  
SECONDARY: 230Y/133 Volts  
TAPS: 2-2 1/2% ANFC and 2-2 1/2% BNFC

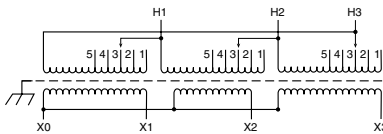

Primary Volts	%	Connect Leads to Tap No.
242	105	1
236	102.5	2
230	100	3
224	97.5	4
219	95	5
Secondary Volts		
230		X1, X2, X3
133 1 phase		X1 & X0 X2 & X0 X3 & X0

**62** PRIMARY: 230 Volts Delta  
SECONDARY: 230Y/133 Volts  
TAPS: 1-5% ANFC and 1-5% BNFC

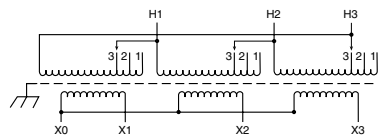

Primary Volts	%	Connect Leads to Tap No.
241	105	1
230	100	2
218	95	3
Secondary Volts		
230		X1, X2, X3
133 1 phase		X1 & X0 X2 & X0 X3 & X0

**57** PRIMARY: 600 Volts  
SECONDARY: 480 Volts  
TAPS: 2, 5% BNFC

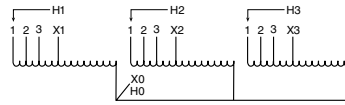

Primary Volts	Alt Rating	Connect Primary Lines To	Inter-Connect	Connect Secondary Lines To
600	480	H1, H2, H3	1	
570	456	H1, H2, H3	2	
540	432	H1, H2, H3	3	
Secondary Volts				
480	380			X1, X2, X3
277 1 phase	220 1 phase			X1 to X0 X2 to X0 X3 to X0

**60** PRIMARY: 208 Volts Delta  
SECONDARY: 208Y/120 Volts  
TAPS: 2-5% BNFC

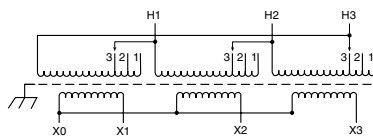

Primary Volts	%	Connect Leads to Tap No.
208	100	1
198	95	2
187	90	3
Secondary Volts		
208		X1, X2, X3
120 1 phase		X1 & X0 X2 & X0 X3 & X0

**63** PRIMARY: 120/208/240/277 Volts  
SECONDARY: 120/240 Volts

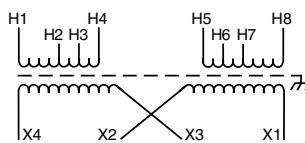

Primary Volts	Connect Primary Lines To	Inter-Connect	Connect Secondary Lines To
120	H1 & H8	H1 to H6 H3 to H8	
208	H1 & H8	H2 to H7	
240	H1 & H8	H3 to H6	
277	H1 & H8	H4 to H5	
Secondary Volts			
240		X2 to X3	X1 & X4
120/240		X2 to X3	X1, X3, X4
120		X1 to X3 X2 to X4	X1 & X4

**58** PRIMARY: 208 Volts  
SECONDARY: 120/240 Volts  
TAPS: 2, 5% BNFC

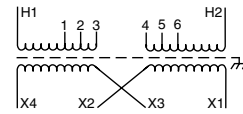

Primary Volts	Connect Primary Lines To	Inter-Connect	Connect Secondary Lines To
208	H1 & H2	3 to 4	
198	H1 & H2	2 to 5	
187	H1 & H2	1 to 6	
Secondary Volts			
240		X2 to X3	X1-X4
120/240		X2 to X3	X1-X2-X4
120		X1 to X3 X2 to X4	X1-X4

**61** PRIMARY: 208 Volts Delta  
SECONDARY: 208Y/120 Volts  
TAPS: 2-2 1/2% ANFC and 2-2 1/2% BNFC

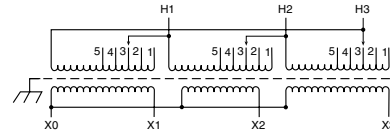

Primary Volts	%	Connect Leads to Tap No.
218	105	1
213	102.5	2
208	100	3
203	97.5	4
198	95	5
Secondary Volts		
208		X1, X2, X3
120 1 phase		X1 & X0 X2 & X0 X3 & X0

**64** PRIMARY: 190/208/220/240 x  
380/416/440/480 Volts  
SECONDARY: 120/240 Volts

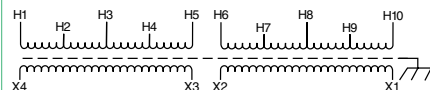

Primary Volts	Connect Primary Lines To	Inter-Connect	Connect Secondary Lines To
190	H1 & H7	H1 to H6 H2 to H7	
208	H1 & H8	H1 to H6 H3 to H8	
220	H1 & H9	H1 to H6 H4 to H9	
240	H1 & H10	H1 to H6 H5 to H10	
380	H1 & H7	H2 to H6	
416	H1 & H8	H3 to H6	
440	H1 & H9	H4 to H6	
480	H1 & H10	H5 to H6	
Secondary Volts			
240		X2 to X3	X1 - X4
120/240		X2 to X3	X1 - X2 - X4
120		X1 to X3 X2 to X4	X1 - X4

**65** PRIMARY: 190/200/208/220 x 380/400/416/440 Volts  
SECONDARY: 110/220 Volts

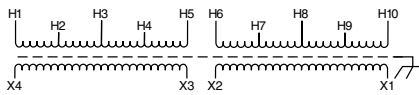

Primary Volts	Connect Primary Lines To	Inter-Connect	Connect Secondary Lines To
190	H1 & H7	H1 to H6 H2 to H7	
200	H1 & H8	H1 to H6 H3 to H8	
208	H1 & H9	H1 to H6 H4 to H9	
220	H1 & H10	H1 to H6 H5 to H10	
380	H1 & H7	H2 to H6	
400	H1 & H8	H3 to H6	
415	H1 & H9	H4 to H6	
440	H1 & H10	H5 to H6	

**Secondary Volts**

Secondary Volts	Inter-Connect	Connect Secondary Lines To
220	X2 to X3	X1-X4
110/220	X2 to X3	X1-X2-X4
110	X1 to X3 X2 to X4	X1-X4

**71** PRIMARY: 240 Volts Delta  
SECONDARY: 480Y/277 Volts  
TAPS: 2, 2 1/2% ANFC & BNFC

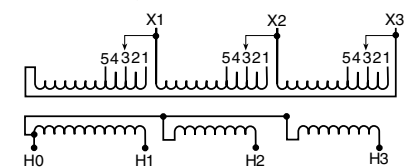

Primary Volts	Connect Primary Lines To	Inter-Connect	Connect Secondary Lines To
252	X1, X2, X3	1	
246	X1, X2, X3	2	
240	X1, X2, X3	3	
234	X1, X2, X3	4	
228	X1, X2, X3	5	

**Secondary Volts**

Secondary Volts	Inter-Connect	Connect Secondary Lines To
480		H1, H2, H3
277 1 phase		H1 to H0 H2 to H0 H3 to H0

**69** PRIMARY: 600 Volts Delta  
SECONDARY: 240 Delta/120 Volts  
TAPS: 2, 2 1/2% ANFC, 4, 2 1/2% BNFC

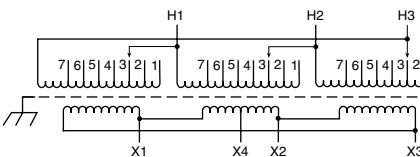

Primary Volts	%	Connect Leads to Tap No.
630	105	1
615	102.5	2
600	100	3
585	97.5	4
570	95	5
555	92.5	6
540	90	7

**Secondary Volts**

Secondary Volts	Inter-Connect	Connect Leads to Tap No.
240		X1, X2, X3
120		X1, X4, or X2, X4

**72** PRIMARY: 380 Volts Delta  
SECONDARY: 208Y/120 Volts  
TAPS: 2, 2 1/2% ANFC, 4, 2 1/2% BNFC

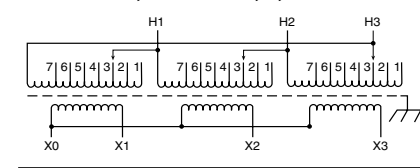

Primary Volts	%	Connect Leads to Tap No.
399	105	1
390	102.5	2
380	100	3
371	97.5	4
361	95	5
352	92.5	6
342	90	7

**Secondary Volts**

Secondary Volts	Inter-Connect	Connect Leads to Tap No.
208		X1, X2, X3
120 1 phase		X1 to X0 X2 to X0 X3 to X0

**70** PRIMARY: 240 Volts Delta  
SECONDARY: 480Y/277 Volts  
TAPS: 2, 5% BNFC

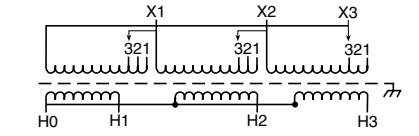

Primary Volts	%	Connect Leads to Tap No.
240	100	1
228	95	2
216	90	3

**Secondary Volts**

Secondary Volts	Inter-Connect	Connect Leads to Tap No.
480		H1, H2, H3
277 1 phase		H1 to H0 H2 to H0 H3 to H0

**73** PRIMARY: 440 Volts Delta  
SECONDARY: 220Y/127 Volts  
TAPS: 2, 5% ANFC & BNFC

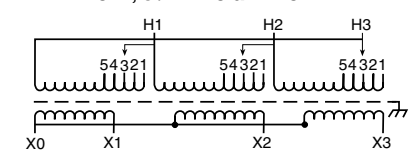

Primary Volts	%	Connect Leads to Tap No.
484	110	1
462	105	2
440	100	3
418	95	4
396	90	5

**Secondary Volts**

Secondary Volts	Inter-Connect	Connect Leads to Tap No.
220		X1, X2, X3
127 1 phase		X1 to X0 X2 to X0 X3 to X0

**74** PRIMARY: 190/200/208/220/  
240 Volts Delta  
SECONDARY: 400Y/231 Volts

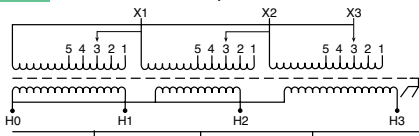

Primary Volts	Connect Primary Lines To	Inter-Connect	Connect Secondary Lines To
240	X1, X2, X3	1	
220	X1, X2, X3	2	
208	X1, X2, X3	3	
200	X1, X2, X3	4	
190	X1, X2, X3	5	

**Secondary Volts**

Secondary Volts	Inter-Connect	Connect Leads to Tap No.
400		H1, H2, H3
231 1 phase		H1 to H0 H2 to H0 H3 to H0

**75** PRIMARY: 190/200/208/220/  
240 Volts Delta  
SECONDARY: 400Y/231 Volts

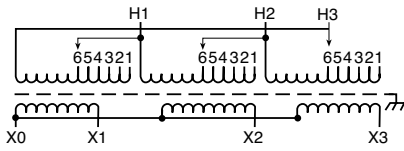

Primary Volts	Connect Primary Lines To	Inter-Connect	Connect Secondary Lines To
240	H1, H2, H3	1	
230	H1, H2, H3	2	
220	H1, H2, H3	3	
210	H1, H2, H3	4	
200	H1, H2, H3	5	
190	H1, H2, H3	6	

**Secondary Volts**

400			X1, X2, X3
231 1 phase			X1 to X0 X2 to X0 X3 to X0

**80** PRIMARY: 480 Volts Delta  
SECONDARY: 208Y/120 Volts  
TAPS: 1-5% ANFC & 1-5% BNFC

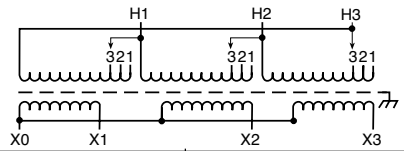

Primary Volts	Connect Primary Lines To	Inter-Connect	Connect Secondary Lines To
504	H1, H2, H3	1	
480	H1, H2, H3	2	
456	H1, H2, H3	3	

**Secondary Volts**

208			X1, X2, X3
120 1 phase			X1 to X0 X2 to X0 X3 to X0

**78** PRIMARY: 277/480 Volts  
SECONDARY: 208/277 Volts  
TAPS: NONE

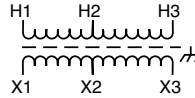

Primary Volts	Connect Primary Lines To	Inter-Connect	Connect Secondary Lines To
277	H1 & H2		
480	H1 & H3		

**Secondary Volts**

208			X1 to X2
277			X1 to X3

**81** PRIMARY: 480 Volts Delta  
SECONDARY: 208Y/120 Volts  
TAPS: 2, 2 1/2% ANFC, 2, 2 1/2% BNFC

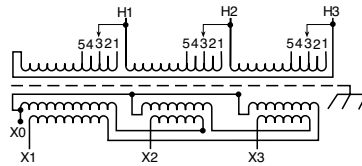

Primary Volts	Connect Primary Lines To	Inter-Connect	Connect Secondary Lines To
504	H1, H2, H3	1	
492	H1, H2, H3	2	
480	H1, H2, H3	3	
468	H1, H2, H3	4	
456	H1, H2, H3	5	

**Secondary Volts**

208			X1, X2, X3
120 1 phase			X1 to X0 X2 to X0 X3 to X0

**79** PRIMARY: 277/480 Volts  
SECONDARY: 208/277 Volts  
TAPS: NONE

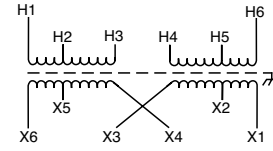

Primary Volts	Connect Primary Lines To	Inter-Connect	Connect Secondary Lines To
277	H1 - H5	H2 to H4	
480	H1 - H6	H3 to H4	

**Secondary Volts**

208		X2 to X4	X1 - X5
277		X3 to X4	X1 - X6

### WALL MOUNTING BRACKET

Required on:  
 Ventilated Units:  
 1Ø, 37.5 and 50 kVA  
 3Ø, 30, 45 and 75 kVA  
 Catalog Number: PL-79912

Encapsulated Units:  
 3Ø dit., 11 kVA — 20 kVA  
 3Ø std. distribution — 15 kVA  
 Catalog Number: PL-79911

Wall mounting brackets are not required on:  
 1Ø units — 25 kVA and below  
 3Ø units — 9 kVA and below

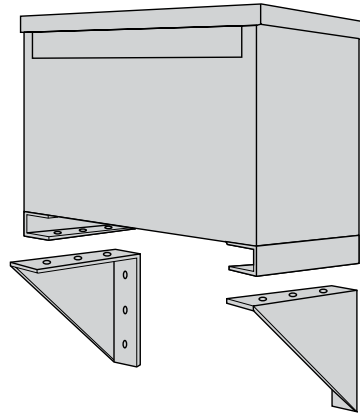

### STANDARD TAPS

The catalog number suffix provides tap information as outlined in chart below:

If the catalog number has no suffix, there are no taps available.

EXAMPLE: T-2-53019-3S

The suffix 3S indicates the unit has two 2.5% (+) ANFC taps and four 2.5% (-) BNFC taps.

Suffix	Tap Arrangement
- 1S	Two 5% (-) BNFC Taps
- 2S	One 5% (+) ANFC Tap and One 5% (-) BNFC Tap
- 3S	Two 2-1/2% (+) ANFC Taps and Four 2-1/2%(-) BNFC Taps
- 4S	Two 2-1/2% (+) ANFC Taps and Two 2-1/2% (-) BNFC Taps
- 5S	Two 5% (+) ANFC Taps and Two 5% (-) BNFC Taps

### THERMAL SWITCH KITS

Acme Thermal Switch Kits are designed for use with single and three phase drive isolation and distribution transformers. Thermal switch kits are available for one or three sensor systems.

Thermal sensors can be field or factory installed in the transformer winding ducts to detect abnormal temperatures. The thermal sensors are a normally closed contact that opens at 200°C ± 10°C and has a current capacity of 5 amps @ 120V or 2.5 amps @ 240V. This contact can activate any number of different types of alarms or mechanisms that could warn of a potential failure.

#### Catalog Number: PL-79900

kVA	Mounting Position	Illustration
27.0 – 220.0	Bottom of the case	Figure 1
275.0 – 750	Top Flange of the Core Bracket	Figure 2

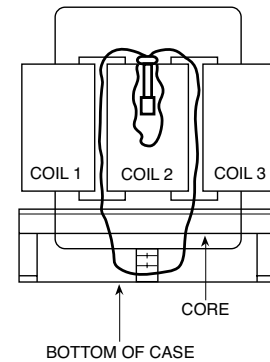

Figure 1

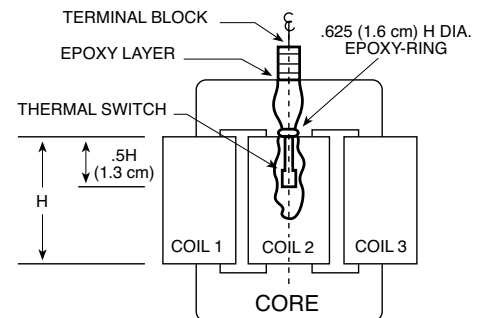

Figure 2

Acme's mechanical transformer lug kits contain all of the hardware necessary to provide satisfactory transformer terminations. Lug kits are available in sizes from 27 kVA to 660 kVA.

Acme lugs are of the dual rated single pole solderless type, made from high strength aluminum alloy. To provide the best in low contact resistance, all lugs in these kits are plated.

**Lug Kits**

Catalog Number	Transformer kVA size	Wire Range Al or Cu	Kit Contains		
			Quantity	Nuts and Bolts	Quantity
Lug 1	37 1/2 1-phase	2 -14	8	1/4 - 20 x 3/4	8
	27 - 45 3-phase	250 mcm - 6	4		
Lug 2	50 - 75 1-phase	250 mcm - 6	12	1/4 - 20 x 3/4	8
	51 - 118 3-phase		4 - 20 x 13/4	8	
Lug 3	100 -167 1-phase	250 mcm - 6	3	1/4 - 20 x 3/4	3
	145 - 300 3-phase	600 mcm - 2	22	3/8 - 16 x 2	16
Lug 4	440 - 660 3-phase	600 mcm - 2	29	3/8 - 16 x 2	8

**Weather Shields**

Catalog Number	Weight (Lbs.)(Kg.)
WSA1	6 (2.7)
WSA2	7 (3.2)
WSA3	8 (3.6)
WSA4	8 (3.6)
WSA5	10 (4.5)
WSA6	10 (4.5)
WSA8	7 (3.2)
WSB3	30 (13.6)
WSB4	32 (14.5)

**SPARE PARTS**

**Top Cover**

Catalog Number	Weight (Lbs.)(Kg.)
SA1701319	14 (6.4)
SA2701319	16 (7.3)
SA3701319	20 (9.1)
SA4701319	34 (15.4)
SA6701319	17 (7.7)

**Side Panel**

Catalog Number	Weight (Lbs.)(Kg.)
SA1701320	11 (5.0)
SA2701320	13 (5.9)
SA3701320	19 (8.6)
SA4701320	34 (15.4)

**Front/Rear Panel**

Catalog Number	Weight (Lbs.)(Kg.)
SA1701321	13 (5.9)
SA2701321	15 (6.8)
SA3701321	21 (9.5)
SA4701321	35 (15.9)
SA7701321	16 (7.3)

**SPECIFICATION GUIDE FOR DRY TYPE DISTRIBUTION TRANSFORMERS**

- 1.0 Dry Type Transformers:
- 1.0.0 The following information should be utilized only by trained technical personnel. If you need assistance, please contact Acme's Technical Services Department at 800-334-5214.
- 1.0.1 Provide dry type, enclosed and ventilated transformers as indicated herein. Transformers shall be Acme or approved equal.
- 1.0.2 Transformers shall be designed, constructed and rated in accordance with UL, CSA, NEMA, ANSI, IEEE, and OSHA standards.
- 1.0.3 Transformers rated 27 kVA and larger, single and three phase shall be the ventilated type, incorporating a 220 degree C insulation system and designed not to exceed 150 degree C temperature rise above a 40 degree C ambient under full load conditions. Taps are to be provided on the primary side of the transformer as follows:
- (a) 2 - 2.5% above normal full capacity.  
4 - 2.5% below normal full capacity.
  - or-
  - (b) 2 - 2.5% above normal full capacity.  
2 - 2.5% below normal full capacity.
- Alternate 1: 115 degree C rise transformers shall incorporate a 220 degree C insulation system and be designed not to exceed 115 degree C temperature rise above a 40 degree C ambient under full load conditions. In addition, the transformer shall have the ability to carry a continuous 15% overload without exceeding a 150 degree C rise above ambient.
- Alternate 2: 80 degree C rise Transformers shall incorporate a 220 degree C insulation system and be designed not to exceed 80 degree C temperature rise above a 40 degree C ambient under full load conditions. In addition, the transformer shall have the ability to carry a continuous 30% overload without exceeding a 150 degree C rise above ambient.
- 1.0.4 Transformer enclosure finish must be ASA 61 gray powder polyurethane paint. Transformer enclosure temperature shall not exceed 50 degrees C plus the ambient under any condition of loading at any specified temperature rise at or below 150 degrees C.
- 1.0.5 Transformer enclosure shall be UL/NEMA Type 2 and UL 3R Listed with the addition of a weather shield and shall be so marked on the transformer.
- 1.0.6 Transformer shall incorporate an electrostatic shield for the attenuation of voltage spikes, line noise, and transients.
- 1.0.7 Single phase transformers and three phase transformers terminate in copper or aluminum bus bar.
- 1.0.8 Transformer coils designed and manufactured for increased insulation life, cooler operation, and lower losses.
- 1.0.9 Transformers must operate at audible sound levels below NEMA Standard ST-20. Sound levels will not exceed the following:
- |               |       |
|---------------|-------|
| 30 - 50 kVA   | 45 db |
| 51 - 150 kVA  | 50 db |
| 151 - 300 kVA | 55 db |
| 301 - 500 kVA | 60 db |
| 501 - 750 kVA | 65 db |
- Transformers must incorporate vibration isolation pads in their construction located between the transformer core and coil assembly and the transformer case. External vibration isolation pads will not be used as they tend to increase audible noise. Transformers shall be floor mounted on a concrete pad. All connections to the transformer will be made by means of flexible metallic conduit.
- 1.0.10 Transformer enclosure shall be grounded per the National Electric Code.
- 1.0.11 Transformers shall be dry-type 600 volt class, kVA rating as indicated. Contractor to provide all necessary lugs for all transformers.
- 1.0.12 Complete shop drawings must be submitted for approval on all dry type transformers.
- 1.0.13 Typical performance data must be submitted for approval on all transformers. Factory tests must be made in accordance with the latest revisions of ANSI Test Code C57.12.91 for Dry Type Transformers. Performance data provided must contain but not be limited to:
- (a) No load losses.

- (b) Full load losses.
- (c) Polarity and phase rotation.
- (d) Impedance at reference temperature.
- (e) Efficiencies at 25, 50, 75, and 100% load.
- (f) Regulation at 100% and 80% power factor.
- (g) Audible sound level.
- (h) Dimensions and weight.
- (i) Applied potential test.
- (j) Induced potential test.
- (k) Excitation current.
- (l) IR, IX, and IZ percentages.
- (m) Reference and ambient temperature.

1.0.14 Warranty: Transformers must be warranted against defects in materials, workmanship, and performance for ten years from date of manufacture.

- (i) Applied potential test.
- (j) Induced potential test.
- (k) Excitation current.
- (l) IR, IX, and IZ percentages.
- (m) Reference and ambient temperature.

1.0.14 Warranty: Transformers must be warranted against defects in materials, workmanship, and performance for ten years from date of manufacture.

**SPECIFICATION GUIDE FOR SINGLE AND THREE PHASE ENCAPSULATED TRANSFORMERS**

1.0 Dry Type Transformers:

1.0.0 The following information should be utilized only by trained technical personnel. If you need assistance, please contact Acme's Technical Services Department at 800-334-5214.

1.0.1 Provide dry type, enclosed, epoxy encapsulated transformers as indicated and specified herein. Transformers must be Acme or approved equal.

1.0.2 Transformers must be designed, constructed and rated in accordance with UL, CSA, NEMA, ANSI, IEEE, and OSHA standards.

1.0.3 Transformers 3.0 - 75 kVA shall be compound filled, incorporating a 180 degree C insulation system and designed not to exceed a 115 degree C temperature rise above a 40 degree C ambient under full load conditions. Taps are to be provided on the primary side of the transformer. The catalog number suffix will provide the tap information outlined below:

SUFFIX TAP ARRANGEMENT

- 1S 2-5% BNFC
- 2S 1-5% ANFC & 1-5% BNFC
- 3S 2-2.5% ANFC & 4-2.5% BNFC
- 4S 2-2.5% ANFC & 2-2.5% BNFC
- 5S 2-5% ANFC & 2-5% BNFC

1.0.4 Transformer enclosure finish must be ASA 61 gray powder polyurethane paint.

1.0.5 Transformer enclosure temperature shall not exceed 65 degrees C plus the ambient.

1.0.6 Transformer enclosure shall be UL/NEMA Type 3R and so marked on the transformer.

1.0.7 Transformer shall incorporate an electrostatic shield for the attenuation of voltage spikes, line noise and transients.

1.0.8 Transformer coils are typically wound with aluminum or copper for increased insulation life, cooler operation and lower losses.

1.0.9 All primary tap connections and both primary and secondary phase conductors must be either copper wire or copper bus bar.

- 1.0.10 Transformers must operate at audible sound levels below ANSI/NEMA Standard ST-20. Sound levels will not exceed the following:
- |              |       |
|--------------|-------|
| Up to 9 kVA  | 40 db |
| 10 - 50 kVA  | 45 db |
| 51 - 150 kVA | 50 db |
- 1.0.11 Transformer enclosures shall be grounded per the National Electric Code.
- 1.0.12 Complete shop drawings must be submitted for approval on all Dry Type Transformers.
- 1.0.13 Typical performance data must be submitted for approval on all transformers. Factory tests must be made in accordance with the latest revisions of ANSI Test Code C57.12.91 for Dry Type Transformers. Performance data must contain but not be limited to:
- No load losses.
  - Full load losses.
  - Polarity and phase rotation.
  - Impedance at reference temperature.
  - Efficiencies at 25, 75, and 100% load.
  - Regulation at 100% and 80% power factor.
  - Audible sound level.
  - Insulation class and rated temperature rise.
  - Dimensions and weight.
  - Applied potential test.
  - Induced potential test.
  - Excitation current.
  - IR, IX, and IZ percentages.
  - Reference and ambient temperature.
- 1.0.14 Warranty: Transformer must be warranted against defects in materials, workmanship and performance for ten years from date of manufacture.

### **SPECIFICATION GUIDE FOR NON-LINEAR LOAD ISOLATION® TRANSFORMERS**

- 1.0 Dry Type Transformers:
- 1.0.0 The following information should be utilized only by trained technical personnel. If you need assistance, please contact Acme's Technical Services Department at 800-334-5214.
- 1.0.1 Provide dry type, enclosed, and ventilated transformers as indicated and specified herein. Transformers must be Acme or approved equal. Transformers must be UL listed for non-sinusoidal current loads of a specified K Factor (UL Standard 1561), CSA certified and labeled as such.
- 1.0.2 For sizes 15 kVA and larger, low voltage dry transformers will be ventilated type, incorporating a 220 degree C insulation system and designed not to exceed 150 degree C temperature rise above a 40 degree C ambient under full load conditions. Taps will be provided on the primary side of the transformer. There will be 2, 2.5% taps above normal full capacity and 4, 2.5% taps below normal full capacity.
- Alternate 1: 115 degree C rise Transformers shall incorporate a 220 degree C insulation system and be designed not to exceed 80 degree C temperature rise above a 40 degree C ambient under full load conditions. In addition, the transformer shall have the ability to carry a continuous 15% overload without exceeding a 150 degree C rise above ambient.
- Alternate 2: 80 degree C rise Transformers shall incorporate a 220 degree C insulation system and be designed not to exceed 80 degree C temperature rise above a 40 degree C ambient under full load conditions. In addition, the transformer shall have the ability to carry a continuous 30% overload without exceeding a 150 degree C rise above ambient.
- 1.0.3 Transformers shall incorporate an electrostatic shield for the attenuation of voltage spikes, line noise, and transients.
- 1.0.4 Transformers must be designed to handle non-linear loads and the adverse effects of harmonics. Transformer coils will be wound with foil to minimize the heating effects caused by harmonic currents.
- 1.0.5 Transformers must be able to power non-linear loads with a K-Factor as high as 20.
- 1.0.6 Transformers must operate at audible sound levels below NEMA ST-20. Sound levels will not exceed the following:
- |              |        |
|--------------|--------|
| 30 - 50 kVA  | 45 db* |
| 51 - 150 kVA | 50 db* |



- 151 - 300 kVA      55 db\*
- 301 - 500 kVA      60 db\*

\* Sound levels are based on transformers with a K-Factor of 4 and a temperature rise of 150 degrees centigrade. Enclosed, ventilated transformers must incorporate vibration dampening pads in their construction, located between the transformer core and coil assembly and the transformer case. External vibration dampening pads will not be used on enclosed, ventilated designs as they tend to increase audible noise. Transformers 15 kVA and larger shall be floor mounted on a concrete pad. All connections to the transformer will be made by means of flexible metallic conduit.

- 1.0.7 Transformers shall incorporate a neutral conductor sized at 2 times rated phase current. Transformer cases shall be grounded per the National Electric Code.
- 1.0.8 Transformers shall be 60 Hz, 480 or 600 volts delta primary, 208Y/120 volt secondary. kVA rating as indicated. Contractor to provide all necessary lugs for all transformers. Transformer enclosures shall be Type 2 and UL-3R listed with the addition of a weather shield.
- 1.0.9 Complete shop drawings must be submitted for approval on all dry type transformers.
- 1.0.10 Typical performance data must be submitted for approval on all transformers. Factory tests must be made in accordance with the latest revisions of ANSI Test Code C57.12.91 for Dry Type Transformers. Performance data must contain but not be limited to:
  - (a) No load losses.
  - (b) Full load losses.
  - (c) Polarity and phase rotation.
  - (d) Impedance at reference temperature.
  - (e) Efficiencies at 25, 75, 50 and 100% load.
  - (f) Regulation at 100% and 80% power factor.
  - (g) Audible sound level.
  - (h) Insulation class and rated temperature rise.
  - (i) Dimensions and weight.
  - (j) Applied potential test.
  - (k) Induced potential test.
  - (l) Excitation current.
  - (m) IR, IX, and IZ percentages.
  - (n) Reference and ambient temperature.
- 1.0.11 Warranty: Transformers must be warranted against defects in materials, workmanship and performance for ten years from date of manufacture.

**SPECIFICATION GUIDE FOR DRIVE ISOLATION® TRANSFORMERS**

- 1.0 Dry Type Transformers:
  - 1.0.0 The following information should be utilized only by trained technical personnel. If you need assistance, please contact Acme's Technical Services Department at 800-334-5214.
  - 1.0.1 Provide dry type, enclosed, epoxy encapsulated transformers as indicated and specified herein. Transformers shall be designed for use with AC/DC Drive applications and labeled as such.
  - 1.0.2 Transformers shall be designed, constructed and rated in accordance with UL, CSA, NEMA, ANSI, IEEE, and OSHA standards.
  - 1.0.3 Transformers 7.5 - 20 kVA shall be three phase, compound filled, incorporating a 180 degree C insulation system and designed not to exceed a 115 degree C temperature rise above a 40 degree C ambient under full load conditions. Taps are provided on the primary side of the transformer as follows:
    - (a) 1-5% above normal full capacity.
    - (b) 1-5% below normal full capacity.
 Transformers 27 - 750 kVA shall be the ventilated type, incorporating a 220 degree C insulation system and designed not to exceed a 150 degree C temperature rise above a 40 degree C maximum ambient under full load conditions. Taps are to be provided on the primary side of the transformer as follows:
    - (a) 2 - 2.5% above normal full capacity.
    - (b) 2 - 2.5% below normal full capacity.
 Alternate 1: 115 degree C rise transformers shall incorporate a 220 degree C insulation system and be designed not to exceed a 115 degree C temperature rise above a 40 degree C maximum ambient under full load conditions.  
 Alternate 2: 80 degree C rise transformers shall incorporate a 220 degree C insulation system and be designed not to exceed 80

degree C temperature rise above a 40 degree C maximum ambient under full load conditions.

- 1.0.4 Transformer enclosure finish must be ASA 61 gray powder polyurethane paint. Ventilated transformer enclosure temperature shall not exceed 50 degrees C plus the ambient. Compound filled transformer enclosure temperature shall not exceed 65 degrees C, plus the ambient.
- 1.0.5 Compound filled transformer enclosure shall be UL/NEMA Type 3R and so marked on the transformer (7.5 - 20 kVA). No weather shield is required. Ventilated transformer enclosure shall be UL/NEMA Type 2 and UL-3R listed with the addition of a weather shield and shall be so marked on the transformer (27 - 750 kVA).
- 1.0.6 Transformers shall incorporate an electrostatic shield for the attenuation of voltage spikes, line noise, and transients.
- 1.0.7 Transformers up to 220 kVA shall terminate in copper bus bar or copper wire.
- 1.0.8 Transformer coils must be wound with aluminum strip conductors for increased insulation life, cooler operation and lower losses.
- 1.0.9 Transformers must operate at audible sound levels below NEMA standard ST-20. Sound levels will not exceed the following:
- |               |       |
|---------------|-------|
| up to 9kVA    | 40 db |
| 10 - 50 kVA   | 45 db |
| 51 - 150 kVA  | 50 db |
| 151 - 300 kVA | 55 db |
| 301 - 500 kVA | 60 db |
| 501 - 750 kVA | 65 db |
- Transformers must incorporate vibration isolation pads in their construction located between the transformer core and coil assembly and the transformer case, (27 - 750 kVA).
- External vibration pads should not be used as they tend to increase audible noise. Transformers shall be floor mounted on a concrete pad. All connections to the transformer will be made by means of flexible metallic conduit.
- 1.0.10 Transformer enclosure shall be grounded per the National Electrical Code.
- 1.0.11 Transformer voltages shall be as follows:
- 460 Delta - 460Y/266
  - 460 Delta - 230Y/133
  - 575 Delta - 230Y/133
  - 575 Delta - 460Y/266
  - 230 Delta - 230Y/133
  - Other
- Transformer shall be 60 Hz. kVA rating as indicated. Contractor to provide all necessary lugs for all transformers.
- 1.0.12 Complete shop drawings must be submitted for approval on all dry type transformers.
- 1.0.13 Typical performance data must be submitted for approval on all transformers. Factory tests must be made in accordance with the latest revisions of ANSI Test Code C57.12.91 for Dry Type Transformers. Performance data provided must contain, but not be limited to:
- No load losses.
  - Full load losses.
  - Polarity and phase rotation.
  - Impedance at reference temperature.
  - Efficiencies at 25, 75, 50 and 100% load.
  - Regulation at 100% and 80% power factor.
  - Audible sound level.
  - Insulation class and rated temperature rise.
  - Dimensions and weight.
  - Applied potential test.
  - Induced potential test.
  - Excitation current.
  - IR, IX, and IZ percentages.
  - Reference and ambient temperature.
- 1.0.14 Warranty: Transformers must be warranted against defects in materials, workmanship and performance for ten years from date of manufacture.

Underwriters' Laboratories, Inc. is an independent not for profit organization which tests products for safety.

Acme's transformers are designed and manufactured to comply with UL Standard 506, 1561, 1012, or 1062 and carry the applicable UL Listing Label. Because of the continuous product evolutions at Acme, it is best that you contact the factory for the current file and guide numbers associated with the listings.

The Canadian Standards Association is the Canadian counterpart to Underwriters' Laboratories. Acme's transformers are also constructed and rated to comply with CSA Standards C22.2-47 and C22.2-66 and carry the CSA Certification Label.

All of Acme's transformers are manufactured to meet National Electrical Code requirements.

Other Agencies and Standards:

National Electrical Manufacturers Association (NEMA)

ST-20 1992 (R1978)

American National Standards Institute (ANSI)

OSHA

IEEE

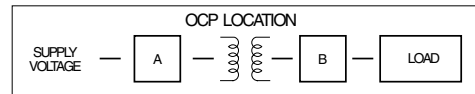

**How to overcurrent protect (OCP) 600 volt class transformers and associated wiring in accordance with the '99 National Electric Code (Articles 450-3(b) and 240-3 (j))**

Case	Type of Supply Voltage	Phase	Number of Wires on Secondary	Protection Required	OCP Location	Primary		Secondary	
						Current (amps)	OCP (% of Rating)	Current (amps)	OCP (% of Rating)
1	Main	10	2	Primary Only	A	$\geq 9$ $< 9, \geq 2$ $< 2$	125 ① 167 Maximum 300 Maximum	Not Required	
2	Main	10 30	More Than 2 Not Applicable	Primary and Secondary ②	A and B	$\geq 9$ $< 9, \geq 2$ $< 2$	125 ① 167 Maximum 300 Maximum	$\geq 9$ $< 9$	125 ① 167 Maximum
3	Feeder Circuit with OCP	10	2	None on Either	—		Not Required	Not Required	
4	Feeder Circuit with OCP	10 30	More Than 2 Not Applicable	Secondary Only ②	B		Not Required	9 $< 9$	125 ① 167 Maximum



### Acme® Transformer™ Products vs. U/L Insulation Systems & U/L Standards

Acme Construction Style	Acme Catalog Product Name	U/L Standard	U/L Product Catalog	U/L File Number	U/L Listed Control Number	U/L Insulation Number	Insulation System Temperature/C	kVA Single Phase	kVA Three Phase
Enclosed	General Purpose and Buck-Boost	506	XPTQ	E79947V1	50B8	B3223	130	.50-.150	N/A
	General Purpose and Buck-Boost and DIT	506	XPTQ	E79947V1	50B8	X3221 H3221	155 180	.25-5.0 7.5-25.0	N/A 7.5-75.0
Compound Filled (Encapsulated)	Panel Trans®	1062	YEFR	E56936V1	N/A	H3180	180	5.0	N/A
	Hardwired CVR	1012	QQFU	E86492V1	6B81	B3223	130	.25-3.0	N/A
						X3221	155	5.0-15.0	N/A
	Portable PLC	1012	QQFU	E86492V1	60B1	B3223	130	.25-2.0	N/A
Open Core & Coil	Industrial Control	506	XPTQ	E79947V1	50B8	B3223	130	.050-5.0	N/A
Air Cooled Ventilated & Non Ventilated	General Purpose Opti-Miser® & DIT	1561	XQNX	E12547V3	542B	C3222	220	37.5-250.0	25-1000
Enclosed	Air Conditioning and Refrigeration Appliance	NONE	NONE	NONE	N/A	NONE	130	.085-2.0	N/A

① % of rated current (or next higher standard rating).

② In cases where the secondary is overcurrent protected, the primary overcurrent protection rating can be no more than 250% (2.5 times) full load amps (shown on above chart).

For example, if a 10 kVA, single phase transformer has a 480V primary and a 120/240 secondary, and the secondary is overcurrent protected, maximum primary overcurrent protection rating is 20.8 amps (full load current) x 2.5 (250%) = 52. Therefore, use a standard 50 amp fuse or breaker selected from NEC Section 240-6 (below).

Section 240-6 of the 1999 National Electrical Code. The standard ampere ratings

for fuses and inverse time circuit breakers shall be considered 15, 20, 25, 30, 35, 40, 45, 50, 60, 70, 80, 90, 100, 110, 125, 150, 175, 200, 225, 250, 300, 350, 400, 450, 500, 600, 700, 800, 1000, 1200, 1600, 2000, 2500, 3000, 4000, 5000 and 6000 amperes.

Exception: Additional standard ratings for fuses shall be considered 1, 3, 6, 10, and 601. "Extracted by permission from ANSI/NFPA 70-1999, National Electrical Code",

Copyright©,1999, National Fire Protection Association, Boston, MA."

Acme Electric—Power Distribution Products Division has never used polychlorinated biphenyls (PCBs) in the manufacture of our quality products.

This alphanumerical listing of catalog numbers has been prepared to help you locate the appropriate page, when only the catalog number is known. It is arranged in alphanumerical order according to the first letter of the catalog number.

Catalog Number	Page Number	Catalog Number	Page Number	Catalog Number	Page Number	Catalog Number	Page Number
62000P2S02	179	70003K	176	A3112K0310B	137	AA51402024	173
62001P2S02	179	70004K	176	A3150K0310B	137	AA51402028	173
62002P2S02	179	70005K	176	AA50001120	172	AA51402030	173
62003P2S02	179	70010K	176	AA50002024	172	AA51402117	173
62004P2S02	179	70011K	176	AA50002030	172	AA51702012	171
62005P2S02	179	70012K	176	AA50002042	172	AA51702015	171
62010P2S02	179	70013K	176	AA50152006	172	AA51702018	171
62011P2S02	179	70014K	176	AA50152009	172	AA51702022	171
62012P2S02	179	70015K	176	AA50152012	172	AA51852012	173
62013P2S02	179	70020K	177	AA50152015	172	AA51852015	173
62014P2S02	179	70021K	177	AA50152018	172	AA51852018	173
62015P2S02	179	70022K	177	AA50152022	172	AA51852022	173
62020P2S02	179	70023K	177	AA50182009	171	AA51852024	173
62021P2S02	179	70024K	177	AA50182012	171	AA51852028	173
62022P2S02	179	70025K	177	AA50182015	171	AA51852030	173
62023P2S02	179	70030K	177	AA50182018	171	AA51852117	173
62024P2S02	179	70031K	177	AA50302006	171	AA52201220	171
62025P2S02	179	70032K	177	AA50302009	172	AA52202018	171
62030P2S02	180	70033K	177	AA50302012	172	AA52202022	171
62031P2S02	180	70034K	177	AA50302015	172	AA52202024	171
62032P2S02	180	70035K	177	AA50302018	172	AA52402015	173
62033P2S02	180	70040K	177	AA50302022	172	AA52402018	173
62034P2S02	180	70041K	177	AA50362009	171	AA52402024	173
62035P2S02	180	70042K	177	AA50362012	171	AA52402030	173
62040P2S02	180	70043K	177	AA50362015	171	AA52402038	173
62041P2S02	180	70044K	177	AA50362018	171	AA52402117	173
62042P2S02	180	70045K	177	AA50502006	173	AA53002015	174
62043P2S02	180	70050K	177	AA50502009	173	AA53002018	174
62044P2S02	180	70051K	177	AA50502012	173	AA53002024	174
62045P2S02	180	70052K	177	AA50502015	173	AA53002030	174
62050P2S02	180	70053K	177	AA50502018	173	AA53002038	174
62051P2S02	180	70054K	177	AA50502022	173	AA53002117	174
62052P2S02	180	70055K	177	AA50502024	173	AA53601220	171
62053P2S02	180	70060K	177	AA50602009	171	AA53602024	171
62054P2S02	180	70061K	177	AA50602012	171	AA53602030	171
62055P2S02	180	70062K	177	AA50602015	171	AA53602033	171
62060P2S02	180	70063K	177	AA50602018	171	AA53602038	171
62061P2S02	180	70064K	177	AA50902012	171	AA53752018	174
62062P2S02	180	70065K	177	AA50902015	171	AA53752024	174
62063P2S02	180	70070K	177	AA50902018	171	AA53752030	174
62064P2S02	180	70071K	177	AA50902022	171	AA53752038	174
62065P2S02	180	70072K	177	AA50952009	173	AA53752117	174
62070P2S02	180	70073K	177	AA50952012	173	AA54501220	171
62071P2S02	180	70074K	177	AA50952015	173	AA54502030	171
62072P2S02	180	70075K	177	AA50952018	173	AA54502033	171
62073P2S02	180	70080K	178	AA50952022	173	AA54502038	171
62074P2S02	180	70081K	178	AA50952024	173	AA54602024	174
62075P2S02	180	70082K	178	AA50952028	173	AA54602030	174
62080P2S02	180	70083K	178	AA50952030	173	AA54602038	174
62081P2S02	180	70084K	178	AA51152012	171	AA54602117	174
62082P2S02	180	70085K	178	AA51152015	171	AA55501220	172
62083P2S02	180	A3006K0310B	137	AA51152018	171	AA55502030	172
62084P2S02	180	A3009K0310B	137	AA51152022	171	AA55502033	172
62085P2S02	180	A3015K0310B	137	AA51402012	173	AA55502038	172
70000K	176	A3030K0310B	137	AA51402015	173	AA56252024	174
70001K	176	A3045K0310B	137	AA51402018	173	AA56252030	174
70002K	176	A3075K0310B	137	AA51402022	173	AA56252033	174

Catalog Number	Page Number	Catalog Number	Page Number	Catalog Number	Page Number	Catalog Number	Page Number
AA56252038	174	AE060150	94	ALRC003TBC	66	CE030250	96
AA56252117	174	AE060250	94	ALRC004LWE	68	CE030350	96
AA56501120	172	AE060350	94	ALRC004TBC	66	CE030500	96
AA56502024	172	AE060500	94	ALRC006LWE	68	CE030750	96
AA56502030	172	AE060750	94	ALRC006TBC	66	CE040050	96
AA56502042	172	AE070050	93	ALRC008LWE	68	CE040100	96
AA57901120	172	AE070100	93	ALRC008TBC	66	CE040150	96
AA57902024	172	AE070150	93	ALRC012LWE	68	CE040250	96
AA57902030	172	AE070250	93	ALRC012TBC	66	CE040350	96
AA57902042	172	AE070350	93	ALRC016LWE	68	CE040500	96
AA58002024	174	AE070500	93	ALRC016TBC	66	CE040750	96
AA58002030	174	AE070750	93	ALRC025LWE	68	CE050050	95
AA58002038	174	AE120050	94	ALRC025TBC	66	CE050150	95
AA58002048	174	AE120100	94	ALRC027LWE	68	CE050250	95
AA58002117	174	AE120150	94	ALRC027TBC	66	CE050350	95
AA59902024	174	AE120250	94	ALRC035LWE	68	CE050500	95
AA59902042	174	AE120350	94	ALRC035TBC	66	CE050750	95
AA59902055	174	AE120500	94	ALRC045LWE	68	CE060050	96
AA59902117	174	AE120750	94	ALRC045TBC	66	CE060075	96
AC1005	181	ALRB002LWE	68	ALRC055LWE	68	CE060100	96
AC1010	181	ALRB002TBC	65	ALRC055TBC	66	CE060150	96
AC1015	181	ALRB003LWE	68	ALRC080LWE	68	CE060250	96
AC1020	181	ALRB003TBC	65	ALRC080TBC	66	CE060300	96
AC1025	181	ALRB004LWE	68	ALRC110CBC	66	CE060350	96
AC1030	181	ALRB004TBC	65	ALRC110LWE	68	CE060500	96
AC1040	181	ALRB006LWE	68	ALRC130CBC	66	CE060750	96
AC1050	181	ALRB006TBC	65	ALRC130LWE	68	CTDD302410	188
AC1060	181	ALRB008LWE	68	ALRC160CBC	66	CTDD303012	188
AC1075	181	ALRB008TBC	65	ALRC160LWE	68	CTDD303612	188
AC1100	181	ALRB012LWE	68	ALRC200CBC	66	CTDD362412	188
AC1150	181	ALRB012TBC	65	ALRC250CBC	66	CTDD363012	188
AC1200	181	ALRB016LWE	68	ALRC300CBC	66	CTDD363212	188
AE010050	93	ALRB016TBC	65	ALRC360CBC	66	CTDD363612	188
AE010075	93	ALRB025LWE	68	ALRC420CBC	66	CTDD363616	188
AE010100	93	ALRB025TBC	65	ALRC480CBC	66	CTDD424212	188
AE010150	93	ALRB027LWE	68	ALRC600CBC	66	CTDD443012	188
AE010250	93	ALRB027TBC	65	AS30327	183	CTDD484816	188
AE010350	93	ALRB035LWE	68	AS30328	183	CTSD121810	187
AE010500	93	ALRB035TBC	65	AS30329	183	CTSD182410	187
AE010750	93	ALRB045LWE	68	AS30330	183	CTSD202010	187
AE020050	93	ALRB045TBC	65	AS30331	183	CTSD202412	187
AE020075	93	ALRB055LWE	68	CE010050	95	CTSD224212	187
AE020100	93	ALRB055TBC	65	CE010075	95	CTSD243012	187
AE020150	93	ALRB080LWE	68	CE010100	95	CTSD243612	187
AE020250	93	ALRB080TBC	65	CE010150	95	CTSD303612	187
AE020300	93	ALRB110CBC	65	CE010250	95	DM112045	109
AE020350	93	ALRB110LWE	68	CE010350	95	DM11206S	110
AE020500	93	ALRB130CBC	65	CE010500	95	DM11208S	110
AE020750	93	ALRB130LWE	68	CE010750	95	DM11215S	110
AE030050	94	ALRB160CBC	65	CE020050	95	DM124025	109
AE030075	94	ALRB160LWE	68	CE020100	95	DM124033S	110
AE030100	94	ALRB200CBC	65	CE020150	95	DM12405S	110
AE030150	94	ALRB250CBC	65	CE020250	95	DM12410S	110
AE030250	94	ALRB300CBC	65	CE020350	95	DM12420	109
AE030350	94	ALRB360CBC	65	CE020500	95	DM13613	109
AE030500	94	ALRB420CBC	65	CE020750	95	DM1480125	109
AE030750	94	ALRB480CBC	65	CE030050	96	DM148017S	110
AE060050	94	ALRC002LWE	68	CE030075	96	DM14805S	110
AE060075	94	ALRC002TBC	66	CE030100	96	DM14810	109
AE060100	94	ALRC003LWE	68	CE030150	96	DM32405	110

Catalog Number	Page Number	Catalog Number	Page Number	Catalog Number	Page Number	Catalog Number	Page Number
DM32410	110	DTGB0344S	61	FS3750	102	MT1000DS	175
DM32420	110	DTGB0404S	61	GP1210000S	24	MT1500DS	175
DMP1120125	110	DTGB04404S	61	GP121000S	24	MT2000DS	175
DMP112025	110	DTGB0514S	61	GP1215000S	24	MT2500DS	175
DMP11204	110	DTGB05504S	61	GP12250S	24	MT3000DS	175
DMP11502	110	DTGB0634S	61	GP123000S	24	MT3750DS	175
DMP124006	110	DTGB06604S	61	GP125000S	24	MT5000DS	175
DMP1240125	110	DTGB0754S	61	GP12500S	24	MT6250DS	175
DMP12402	110	DTGB07704S	61	H3030K0014BCS	47	MT7500DS	175
DMP14801	110	DTGB0934S	61	H3045K0014BCS	47	MT8750DS	175
DMP1504	110	DTGB72S	61	H3075K0014BCS	47	N412121206SSAC	189
DRUB15	111	DTGB9902S	61	H3112K0014BCS	47	N412121206SSC	189
DRUB20	111	DTHA0112S	62	H3150K0014BCS	47	N412121206WSSC	192
DRUBGFI15	111	DTHA0112S	62	H3225K0014BCS	47	N412121208WSSC	193
DRUBGFI15AC	111	DTHA01184S	62	HBL3W100C	161	N412161206SSAC	189
DRUBGFI20	111	DTHA0142S	62	HBL3W50	163	N412161206SSC	189
DRUBGFI20AC	111	DTHA01454S	62	HBL4SA40	164	N412161206WSSC	192
DTFA0112S	60	DTHA0202S	62	HBL4W100C	161	N412161208CSSST	195
DTFA01184S	60	DTHA0274S	62	HBL8SA40	164	N412161208SSAC	189
DTFA0142S	60	DTHA0344S	62	HBL8W100C	161	N412161208SSC	189
DTFA01454S	60	DTHA0404S	62	HBL9W100C	161	N412161208WSSC	193
DTFA01754S	60	DTHA0514S	62	HBLSDSA36	164	N412161210SSAC	190
DTFA0202S	60	DTHA0634S	62	L0540	182	N412161210SSC	190
DTFA02204S	60	DTHA0754S	62	L0560	182	N412161210WSSC	193
DTFA0274S	60	DTHA0934S	62	L1020	182	N412161606SSAC	189
DTFA0344S	60	DTHA72S	62	L1040	182	N412161606SSC	189
DTFA0404S	60	DTHB002754S	62	L1060	182	N412161608CSSST	195
DTFA0514S	60	DTHB006604S	62	L1510	182	N412161608SSAC	189
DTFA0634S	60	DTHB0112S	62	L1515	182	N412161608SSC	189
DTFA0754S	60	DTHB01184S	62	L1520	182	N412161610SSAC	190
DTFA0934S	60	DTHB0142S	62	L1540	182	N412161610SSC	190
DTFA72S	60	DTHB01454S	62	L2010	182	N412162008SSAC	189
DTGA0112S	61	DTHB01754S	62	L2015	182	N412162008SSC	189
DTGA01184S	61	DTHB0202S	62	L2020	182	N412162010SSAC	190
DTGA0142S	61	DTHB02204S	62	L2040	182	N412162010SSC	190
DTGA01454S	61	DTHB0274S	62	L3005	182	N412201606SSAC	189
DTGA01754S	61	DTHB03304S	62	L3010	182	N412201606SSC	189
DTGA0202S	61	DTHB0344S	62	L3015	182	N412201606WSSC	192
DTGA02204S	61	DTHB0404S	62	L3020	182	N412201608CSSST	195
DTGA0274S	61	DTHB04404S	62	L4005	182	N412201608SSAC	189
DTGA02754S	61	DTHB0514S	62	L4010	182	N412201608SSC	189
DTGA03304S	61	DTHB05504S	62	L4015	182	N412201608WSSC	193
DTGA0344S	61	DTHB0634S	62	L5005	182	N412201610SSAC	190
DTGA0404S	61	DTHB0754S	62	L5010	182	N412201610SSC	190
DTGA0514S	61	DTHB0934S	62	L6005	182	N412201610WSSC	193
DTGA0634S	61	DTHB72S	62	Lug 1	218	N412201612CSSST	195
DTGA0754S	61	FS11000	101	Lug 2	208	N412202006SSAC	189
DTGA0934S	61	FS21000	101	Lug 3	208	N412202006SSC	189
DTGA72S	61	FS21500	101	Lug 4	208	N412202006WSSC	192
DTGB002754S	61	FS22000	101	MT0100DS	175	N412202008CSSST	195
DTGB008804S	61	FS23000	101	MT0100SS	175	N412202008SSAC	189
DTGB0112S	61	FS31000	102	MT0230DS	175	N412202008SSC	189
DTGB01184S	61	FS3150	102	MT0230SS	175	N412202008WSSC	193
DTGB0142S	61	FS31500	102	MT0400DS	175	N412202010SSAC	190
DTGB01454S	61	FS32000	102	MT0400SS	175	N412202010SSC	190
DTGB01754S	61	FS3250	102	MT0600DS	175	N412202010WSSC	193
DTGB0202S	61	FS33000	102	MT0600SS	175	N412202012CSSST	195
DTGB02204S	61	FS3350	102	MT0750DS	175	N412202012SSAC	190
DTGB0274S	61	FS350	102	MT0750SS	175	N412202012SSC	190
DTGB03304S	61	FS3500	102	MT1000DS	175	N412202012WSSC	193

Catalog Number	Page Number	Catalog Number	Page Number	Catalog Number	Page Number	Catalog Number	Page Number
N412241608SSAC	189	N412363610SSAC	190	PT0B1150005LS	143	T1500V0370BC	114
N412241608SSC	189	N412363610SSC	190	PT0B1150005SS	143	T153004	23
N412241610SSAC	190	N412363612CSSST	195	PT0B1150007LS	143	T153005	23
N412241610SSC	190	N412363612SSAC	191	PT0B1150007SS	143	T153006	23
N412242006WSSC	192	N412363612SSC	191	PT0B1150010LS	143	T153104	25
N412242008CSSST	195	N412423610SSAC	190	PT0B1150010SS	143	T153105	25
N412242008SSAC	190	N412423610SSC	190	PT0B1150015LS	143	T153106	25
N412242008SSC	190	N412423612SSAC	191	PT0B1150015SS	143	T153929	90
N412242008WSSC	193	N412423612SSC	191	PT0B1150025LS	143	T153930	90
N412242010SSAC	190	N412483610SSAC	190	PT0B1150025SS	143	T153931	90
N412242010SSC	190	N412483610SSC	190	PTBA3150009LS	144	T160830	152
N412242010WSSC	193	N412483612SSAC	191	PTBA3150009SS	144	T160831	152
N412242012WSSC	193	N412483612SSC	191	PTBA3150015LS	144	T160832	152
N412242406WSSC	192	N412483616CSSST	195	PTBA3150015SS	144	T160833	152
N412242408CSSST	195	N412603610SSAC	190	PTBA3150022LS	144	T160834	152
N412242408SSAC	190	N412603610SSC	190	PTBA3150022SS	144	T160835	152
N412242408SSC	190	N412603612SSAC	191	PTBA3150030LS	144	T169430	157
N412242408WSSC	193	N412603612SSC	191	PTBA3150030SS	144	T169431	157
N412242410SSAC	190	N412603616CSSST	195	PTBB3150009LS	145	T169432	157
N412242410SSC	190	PL112600	87	PTBB3150009SS	145	T169433	157
N412242410WSSC	193	PL112601	87	PTBB3150015LS	145	T169434	157
N412242412CSSST	195	PL112602	87	PTBB3150015SS	145	T169435	157
N412242412SSAC	190	PL112603	87	PTBB3150022LS	145	T169436	157
N412242412SSC	190	PL112700	87	PTBB3150022SS	145	T169437	157
N412242412WSSC	193	PL112701	87	PTBB3150030LS	145	T169438	157
N412242416WSSC	193	PL112702	87	PTBB3150030SS	145	T169439	157
N412242420WSSC	193	PL112703	87	SA1701319	208	T179600S	113
N412302406WSSC	193	PL112704	87	SA1701320	208	T179603S	113
N412302408CSSST	195	PL112705	87	SA1701321	208	T179604S	113
N412302408SSAC	190	PL112706	87	SA2701319	208	T179605S	113
N412302408SSC	190	PL112707	87	SA2701320	208	T179608S	113
N412302408WSSC	193	PL79900	217	SA2701321	208	T179609S	113
N412302410SSAC	190	PL79905	102	SA3701319	208	T179615S	113
N412302410SSC	190	PL79906	102	SA3701320	208	T179618S	113
N412302410WSSC	193	PL79907	102	SA3701321	208	T179619S	113
N412302412CSSST	195	PL79908	102	SA4701319	208	T179620S	113
N412302412SSAC	190	PL79911	217	SA4701320	208	T179621S	113
N412302412SSC	190	PL79912	217	SA4701321	208	T179622S	113
N412302412WSSC	193	PL79920	98	SA6701319	208	T179623S	113
N412302420WSSC	193	PL79921	98	SA7701321	208	T179624S	113
N412303008CSSST	195	PL79922	98	T1001K0370BC	114	T179625S	113
N412303008SSAC	190	PL79923	98	T1100V0370BC	114	T179629S	113
N412303008SSC	190	PL79924	98	T111683	133	T179630S	113
N412303010SSAC	190	PL79925	98	T111684	133	T179631S	113
N412303010SSC	190	PL79926	98	T111685	133	T181047	133
N412362408SSAC	190	PL79927	98	T111686	133	T181048	133
N412362408SSC	190	PL79928	98	T111687	133	T181049	133
N412362410SSAC	190	PL79929	98	T113073	134	T181050	133
N412362410SSC	190	PL79930	98	T113074	134	T181051	133
N412362412SSAC	190	PL79931	98	T113075	134	T181052	133
N412362412SSC	190	PT061150005LS	142	T113076	134	T181054	134
N412363008CSSST	195	PT061150005SS	142	T113077	134	T181055	134
N412363008SSAC	190	PT061150007LS	142	T1150K0370BC	114	T181056	134
N412363008SSC	190	PT061150007SS	142	T1150V0370BC	114	T181057	134
N412363010SSAC	190	PT061150010LS	142	T1250V0370BC	114	T181058	134
N412363010SSC	190	PT061150010SS	142	T137920	134	T181059	134
N412363012CSSST	195	PT061150015LS	142	T137921	134	T181061	134
N412363012SSAC	190	PT061150015SS	142	T137922	135	T181062	134
N412363012SSC	190	PT061150025LS	142	T137923	135	T181063	134
N412363016CSSST	195	PT061150025SS	142	T137924	135	T181064	134



Catalog Number	Page Number	Catalog Number	Page Number	Catalog Number	Page Number	Catalog Number	Page Number
T181065	134	T2536161S	25	T3015K0064BS	26	T3075K0064BS	26
T181066	134	T2536171S	25	T3015K0074B	27	T3075K0074B	27
T181217	90	T2536181S	25	T3015K0083BS	31	T3075K0083BS	31
T181219	90	T279740S	21	T3015K0093BS	32	T3075K0093BS	32
T181220	90	T279741S	21	T3015K0170BS	26	T3075K0170BS	26
T181221	90	T279742S	21	T3015K0323BS	32	T3075K0323BS	32
T181223	90	T279743S	21	T3030K0013B	28	T3112K0013B	28
T211688	133	T279744S	21	T3030K0013BC	28	T3112K0013BC	28
T211689	133	T279745S	21	T3030K0013BK13S	54	T3112K0013BK13S	54
T213078	134	T279746S	21	T3030K0013BK13SF	55	T3112K0013BK13SF	55
T213079	134	T279747S	21	T3030K0013BK20S	54	T3112K0013BK20S	54
T243570	135	T279748S	21	T3030K0013BK4S	54	T3112K0013BK4S	54
T243571	135	T2A527121	33	T3030K0013BSB	29	T3112K0013BSB	29
T2527031	33	T2A527131	33	T3030K0013BSF	29	T3112K0013BSF	29
T2527051	33	T2A527151	33	T3030K0013CSH	30	T3112K0023B	30
T2527071	33	T2A527171	33	T3030K0023B	30	T3112K0034B	26
T253007S	23	T2A527181	33	T3030K0034B	26	T3112K0044B	27
T253007SS	23	T2A527191	33	T3030K0044B	27	T3112K0053B	31
T253008S	23	T2A533081S	28	T3030K0053B	31	T3112K0063BK13S	55
T253008SS	23	T2A53308SS	29	T3030K0063BK13S	55	T3112K0074B	27
T253009S	23	T2A533091S	28	T3030K0064BS	26	T3112K0083BS	31
T253009SS	23	T2A53309SS	29	T3030K0074B	27	T3112K0093BS	32
T253010S	23	T2A533101S	28	T3030K0083BS	31	T3150K0013B	28
T253010SS	23	T2A53310SS	29	T3030K0093BS	32	T3150K0013BC	28
T253011S	23	T2A533281S	30	T3030K0170BS	26	T3150K0013BK13S	54
T253011SS	23	T2A533291S	30	T3030K0323BS	32	T3150K0013BK13SF	55
T253012S	23	T2A533401S	30	T3045K0013B	28	T3150K0013BK20S	54
T253012SS	23	T2A533601S	27	T3045K0013BC	28	T3150K0013BK4S	54
T2530134S	23	T2A792681S	26	T3045K0013BK13S	54	T3150K0013BSB	29
T253013S	23	T2A792691S	26	T3045K0013BK13SF	55	T3150K0013BSF	29
T253013SS	23	T2A792701S	26	T3045K0013BK20S	54	T3150K0023B	30
T2530144S	23	T2A793301S	31	T3045K0013BK4S	54	T3150K0034B	26
T253014S	23	T2A793311S	31	T3045K0013BSB	29	T3150K0044B	27
T253014SS	23	T2A793321S	31	T3045K0013BSF	29	T3150K0053B	31
T253060	22	T2A795161S	32	T3045K0013CSH	30	T3150K0063BK13S	55
T253061	22	T2A795171S	32	T3045K0023B	30	T3150K0074B	27
T253062	22	T2A795181S	32	T3045K0034B	26	T3150K0083BS	31
T253063	22	T2A795523S	27	T3045K0044B	27	T3150K0093BS	32
T253064	22	T2A795533S	27	T3045K0053B	31	T3225K0013B	28
T253065	22	T2A795543S	27	T3045K0063BK13S	55	T3225K0013BC	28
T253066	22	T2A795553S	27	T3045K0064BS	26	T3225K0013BK13S	54
T253067	22	T3001M0012B	28	T3045K0074B	27	T3225K0013BK13SF	55
T253107S	25	T3003K0011CSH	30	T3045K0083BS	31	T3225K0013BK20S	54
T253108S	25	T3006K0011CSH	30	T3045K0093BS	32	T3225K0013BK4S	54
T253109S	25	T3009K0011CSH	30	T3045K0170BS	26	T3225K0013BSF	29
T253110S	25	T3015K0013B	28	T3045K0323BS	32	T3225K0023B	30
T253111S	25	T3015K0013BC	28	T3075K0013B	28	T3225K0034B	26
T253112S	25	T3015K0013BK13S	54	T3075K0013BC	28	T3225K0044B	27
T2531131S	25	T3015K0013BK13SF	55	T3075K0013BK13S	54	T3225K0053B	31
T2531141S	25	T3015K0013BK20S	54	T3075K0013BK13SF	55	T3225K0063BK13S	55
T2535153S	23	T3015K0013BK4S	54	T3075K0013BK20S	54	T3225K0083BS	31
T253515SS	23	T3015K0013BSB	29	T3075K0013BK4S	54	T3300K0013B	28
T2535163S	23	T3015K0013BSF	29	T3075K0013BSB	29	T3300K0013BC	28
T253516SS	23	T3015K0013CSH	30	T3075K0013BSF	29	T3300K0013BSF	29
T2535173S	23	T3015K0023B	30	T3075K0023B	30	T3300K0023B	30
T253517SS	23	T3015K0034B	26	T3075K0034B	26	T3300K0034B	26
T2535183S	23	T3015K0044B	27	T3075K0044B	27	T3300K0053B	31
T253518SS	23	T3015K0053B	31	T3075K0053B	31	T3300K0083BS	31
T2536151S	25	T3015K0063BK13S	55	T3075K0063BK13S	55	T335000153S	31

Catalog Number	Page Number	Catalog Number	Page Number	Catalog Number	Page Number	Catalog Number	Page Number
T3500K0013B	28	TA83312	87	TB81303	81	TP530223S	23
T3500K0013BC	28	TA83313	87	TB81304	81	TP530233S	23
T3500K0013BSF	29	TA83314	87	TB81305	81	TP530243S	23
T3500K0023B	30	TA83315	87	TB81306	81	TP531193S	25
T3500K0083BS	31	TA83316	87	TB81307	81	TP531203S	25
T3527101	33	TB080050	82	TB81308	81	TP531213S	25
T3533111S	28	TB080075	82	TB81309	81	TP531223S	25
T353311SS	29	TB080100	82	TB81321	80	TP531233S	25
T3533411S	30	TB080150	82	TB81322	80	TP536491S	22
T3533611S	27	TB080250	82	TB81323	80	TP536503S	22
T3750K0013B	28	TB080350	82	TB81324	80	TP536513S	22
T3750K0013BC	28	TB080500	82	TB81325	80	TPC530193S	24
T3750K0023B	30	TB080750	82	TB81326	80	TPC530203S	24
T3750K0083BS	31	TB081000	82	TB81327	80	WB015K01	42
T379083S	26	TB181141	80	TB81328	80	WB015K02	42
T3792711S	26	TB181142	80	TB81329	80	WB015K03	42
T3793123S	29	TB181143	80	TB83210	85	WB015K04	42
T379312SS	29	TB181144	80	TB83212	85	WB015K05	42
T3793133S	29	TB181146	80	TB83213	85	WB015K06	42
T379313SS	29	TB181148	80	TB83215	85	WB015K07	42
T3793143S	29	TB181149	80	TB83218	85	WB015K08	42
T379314SS	29	TB181150	80	TB83219	85	WB015K09	42
T3793331S	31	TB181151	80	TB83220	85	WC025K01	42
T3793671S	26	TB32403	84	TC533111S	28	WC025K02	42
T3795191S	32	TB32404	84	TC535153S	24	WC025K03	42
T3795511S	27	TB32405	84	TC535163S	24	WC025K04	42
T3796931S	27	TB32406	84	TC535173S	24	WC025K05	42
TA253929	83	TB32669	84	TC535183S	24	WC025K06	42
TA253930	83	TB54523	84	TE1530223S	24	WC025K07	42
TA253931	83	TB54524	84	TE2530193S	24	WC025K08	42
TA254525	84	TB69300	81	TE2530203S	24	WC025K09	42
TA254535	86	TB69301	81	TE2A530213S	24	WC037K01	42
TA254536	86	TB69302	81	TF217437S	21	WC037K02	42
TA254537	86	TB69303	81	TF217439S	21	WC037K03	42
TA254538	86	TB69304	81	TF220105S	28	WC037K04	42
TA254539	86	TB69305	81	TF220155S	28	WC037K05	42
TA281008	83	TB69306	81	TF220255S	28	WC037K06	42
TA281197	86	TB69307	81	TF220505S	28	WC037K07	42
TA281202	84	TB81000	83	TF249873S	21	WC037K08	42
TA281203	84	TB81001	83	TF252520S	21	WC037K09	42
TA281205	84	TB81002	83	TF252794S	21	WC050K01	42
TA281218	83	TB81003	83	TF252795S	21	WC050K02	42
TA281219	83	TB81004	83	TF252796S	21	WC050K03	42
TA281220	83	TB81005	83	TF252797S	21	WC050K04	42
TA281221	83	TB81006	83	TF279260S	22	WC050K05	42
TA281240	86	TB81007	83	TF279261S	22	WC050K06	42
TA281241	86	TB81009	83	TF279262S	22	WC050K07	42
TA83221	85	TB81020	83	TF279263S	22	WC050K08	42
TA83222	85	TB81200	82	TF279264S	22	WC050K09	42
TA83223	85	TB81201	82	TF279265S	22	WC075K01	42
TA83224	85	TB81210	82	TF279266S	22	WC075K02	42
TA83300	86	TB81211	82	TF279267S	22	WC075K03	42
TA83301	86	TB81212	82	TF279300S	21	WC075K04	42
TA83302	86	TB81213	82	TF279301S	21	WC075K05	42
TA83303	86	TB81214	82	TF279302S	21	WC075K06	42
TA83304	86	TB81215	82	TF279303S	21	WC075K07	42
TA83305	86	TB81216	82	TF279304S	21	WC075K08	42
TA83306	86	TB81217	82	TP530193S	23	WC075K09	42
TA83310	87	TB81301	81	TP530203S	23	WC100K01	42
TA83311	87	TB81302	81	TP530213S	23	WC100K02	42

Catalog Number	Page Number	Catalog Number	Page Number	Catalog Number	Page Number	Catalog Number	Page Number
WC100K03	42	WH015K22	43	WI030K10	43	WI112K16	43
WC100K04	42	WH015K23	43	WI030K11	43	WI112K17	43
WC100K05	42	WH015K24	43	WI030K12	43	WI112K18	43
WC100K06	42	WH015K25	43	WI030K13	43	WI112K19	43
WC100K07	42	WH015K26	43	WI030K14	43	WI112K20	43
WC100K08	42	WH015K27	43	WI030K15	43	WI112K21	43
WC100K09	42	WI001M10	43	WI030K16	43	WI112K22	43
WC167K01	42	WI001M11	43	WI030K17	43	WI112K23	43
WC167K02	42	WI001M12	43	WI030K18	43	WI112K24	43
WC167K03	42	WI001M13	43	WI030K19	43	WI112K25	43
WC167K04	42	WI001M14	43	WI030K20	43	WI112K26	43
WC167K05	42	WI001M15	43	WI030K21	43	WI112K27	43
WC167K06	42	WI001M16	43	WI030K22	43	WI150K10	43
WC167K07	42	WI001M17	43	WI030K23	43	WI150K11	43
WC167K08	42	WI001M18	43	WI030K24	43	WI150K12	43
WC167K09	42	WI001M19	43	WI030K25	43	WI150K13	43
WC250K01	42	WI001M20	43	WI030K26	43	WI150K14	43
WC250K02	42	WI001M21	43	WI030K27	43	WI150K15	43
WC250K03	42	WI001M22	43	WI045K10	43	WI150K16	43
WC250K04	42	WI001M23	43	WI045K11	43	WI150K17	43
WC250K05	42	WI001M24	43	WI045K12	43	WI150K18	43
WC250K06	42	WI001M25	43	WI045K13	43	WI150K19	43
WC250K07	42	WI001M26	43	WI045K14	43	WI150K20	43
WC250K08	42	WI001M27	43	WI045K15	43	WI150K21	43
WC250K09	42	WI002M10	43	WI045K16	43	WI150K22	43
WC333K01	42	WI002M11	43	WI045K17	43	WI150K23	43
WC333K02	42	WI002M12	43	WI045K18	43	WI150K24	43
WC333K03	42	WI002M13	43	WI045K19	43	WI150K25	43
WC333K04	42	WI002M14	43	WI045K20	43	WI150K26	43
WC333K05	42	WI002M15	43	WI045K21	43	WI150K27	43
WC333K06	42	WI002M16	43	WI045K22	43	WI225K10	43
WC333K07	42	WI002M17	43	WI045K23	43	WI225K11	43
WC333K08	42	WI002M18	43	WI045K24	43	WI225K12	43
WC333K09	42	WI002M19	43	WI045K25	43	WI225K13	43
WC500K01	42	WI002M20	43	WI045K26	43	WI225K14	43
WC500K02	42	WI002M21	43	WI045K27	43	WI225K15	43
WC500K03	42	WI002M22	43	WI075K10	43	WI225K16	43
WC500K04	42	WI002M23	43	WI075K11	43	WI225K17	43
WC500K05	42	WI002M24	43	WI075K12	43	WI225K18	43
WC500K06	42	WI002M25	43	WI075K13	43	WI225K19	43
WC500K07	42	WI002M26	43	WI075K14	43	WI225K20	43
WC500K08	42	WI002M27	43	WI075K15	43	WI225K21	43
WC500K09	42	WI015M10	43	WI075K16	43	WI225K22	43
WCT242412	186	WI015M11	43	WI075K17	43	WI225K23	43
WCT303012	186	WI015M12	43	WI075K18	43	WI225K24	43
WCT363012	186	WI015M13	43	WI075K19	43	WI225K25	43
WCT363612	186	WI015M14	43	WI075K20	43	WI225K26	43
WCT483616	186	WI015M15	43	WI075K21	43	WI225K27	43
WH015K10	43	WI015M16	43	WI075K22	43	WI300K10	43
WH015K11	43	WI015M17	43	WI075K23	43	WI300K11	43
WH015K12	43	WI015M18	43	WI075K24	43	WI300K12	43
WH015K13	43	WI015M19	43	WI075K25	43	WI300K13	43
WH015K14	43	WI015M20	43	WI075K26	43	WI300K14	43
WH015K15	43	WI015M21	43	WI075K27	43	WI300K15	43
WH015K16	43	WI015M22	43	WI112K10	43	WI300K16	43
WH015K17	43	WI015M23	43	WI112K11	43	WI300K17	43
WH015K18	43	WI015M24	43	WI112K12	43	WI300K18	43
WH015K19	43	WI015M25	43	WI112K13	43	WI300K19	43
WH015K20	43	WI015M26	43	WI112K14	43	WI300K20	43
WH015K21	43	WI015M27	43	WI112K15	43	WI300K21	43

Catalog Number	Page Number	Catalog Number	Page Number	Catalog Number	Page Number	Catalog Number	Page Number
WI300K22	43	WI500K16	43	WI750K10	43	WI750K22	43
WI300K23	43	WI500K17	43	WI750K11	43	WI750K23	43
WI300K24	43	WI500K18	43	WI750K12	43	WI750K24	43
WI300K25	43	WI500K19	43	WI750K13	43	WI750K25	43
WI300K26	43	WI500K20	43	WI750K14	43	WI750K26	43
WI300K27	43	WI500K21	43	WI750K15	43	WI750K27	43
WI500K10	43	WI500K22	43	WI750K16	43	WSA1	208
WI500K11	43	WI500K23	43	WI750K17	43	WSA2	208
WI500K12	43	WI500K24	43	WI750K18	43	WSA3	208
WI500K13	43	WI500K25	43	WI750K19	43	WSA4	208
WI500K14	43	WI500K26	43	WI750K20	43	WSA5	208
WI500K15	43	WI500K27	43	WI750K21	43	WSA6	208























OUR HISTORY IS  
**STRONG, ENGAGING  
AND DEDICATED...**  
JUST LIKE OUR **PEOPLE.**



## Acme Electric Celebrates A Centennial Year To Be Proud Of!

In 1917, Acme Electric began its legacy of producing top performing electrical products in Cleveland, OH. Founded as Acme Electric and Machine Company, the product offering consisted of motor-driven battery chargers, electrical appliances, and electrical generators.

Throughout the 100 years of Acme Electric's existence, we have developed a bold offering of transformer product lines from Low Voltage Distribution Transformers to our NEW Medium Voltage Distribution and 3 Phase Buck Boost Transformers.

As we grow, Acme Electric will continue the tradition of commitment to a diversified mix of Power Quality and Power Conversion products.

2017 will be a year of celebrating new product releases that will solidify Acme Electric's position for the next 100 years.

Learn more about us at [hubbell-acmeelectric.com](http://hubbell-acmeelectric.com)

