

Section G Index

SDN12 Series

NEMA 12 Flanged Single Door Disconnects G3

N412CD, N412CDSS, N412CDSSA Series

ULTIMATE Flanged Single Door
Disconnects G6

N412CSTD, N412CSSSTD Series

ULTIMATE Slope-Top Flanged
Single Door Disconnects G8

SN4 Series

NEMA 4 Flanged Single Door
Disconnects G10

SSN4X Series

NEMA 4 Flanged Single Door
Disconnects G12

ABN12 Series (1494F & 1494D)

NEMA 12 Flanged Single Door
Disconnects G23

WAX-U & WACPX-U Series

NEMA 12 Floor-Mount Disconnects G27

WAXM-U Series (1, 2, 3, 4, 5 Door)

NEMA 12 Heavy-Duty Freestanding
Disconnects G31

WMOD Series

NEMA 12 Modular Freestanding
Disconnects G39

WAX-SSN4, WACPX-SSN4 Series

NEMA 4X Floor-Mount Disconnects G44

WAXM-SSN4 Series

NEMA 4X Freestanding Single & Double
Door Disconnects G47

NEMA 12 Adapter Plates G60

DISCONNECTS





“WM” PREFERRED CUTOUT

FEATURES-SPECIFICATIONS

Applications

These General purpose disconnect enclosures accept major brand disconnect switches and circuit breakers, available with or without Wiegman supplied defeater door handle and handle hardware (door handle supplied on SDN12PL, N412CD and N412CSTD models only).

Enclosures having the “WM” preferred cutout are sized for use with up to 200A disconnect switches and up to 400A circuit breakers unless otherwise specified. The “WM” preferred cutout accepts the smaller operating handle whose mounting hole centers are 4.677 in. apart. “WM” preferred cutouts are standard in most wall-mount enclosures and some select large mild steel enclosures. They are also present on all standard stainless steel offerings. Mild steel operator adapter plates with brand specific “WM” preferred cutouts are available for enclosures with a rectangular universal cutout.

“WM” preferred cutouts are designed to house the following:

Allen-Bradley

- 1494V disconnect switches with flange-mount variable depth operating mechanisms and 1494V flange-mounted variable depth operating mechanisms for circuit breakers
- 140U flexible cable operating mechanisms and 140U molded case circuit breakers
- 1494C cable-operated disconnect switches with flange-mount handles
- 194RC cable-operated flange-mount handles for use with the NFPA 79 compliant 194R IEC rotary disconnect switches

Allen-Bradley 1494V-R1, -R2 and -W2 operating handles and Allen-Bradley 1494F disconnect devices or 1494D circuit breaker operators will NOT fit these enclosures.

See Pages G23-G26 for ABN12 1494F & 1494D models

- **ABB Controls** flange-mount variable-depth operating mechanism for disconnect switches and circuit breakers. Also the cable version for circuit breakers.
- **Eaton Cutler-Hammer** Type C361 flange-mount variable-depth operating mechanisms with disconnect switches and Type C371 flange-mount variable-depth operating mechanisms for circuit breakers.

- **General Electric** Type STDA flange handles and variable-depth operating mechanisms for disconnect switches and circuit breakers. Also SPECTRAFLEX™ cable operators for circuit breakers
- **Siemens ITE Max-Flex™** flange-mount variable-depth operating handles for circuit breakers.
- **Schneider Square D®** Class 9422 disconnect switches with flange-mount variable-depth operating mechanisms or cable mechanisms and Class 9422 flange-mount variable-depth operating mechanism or cable mechanisms for circuit breakers.

These enclosures will not accept Schneider Square D® Class 9422 bracket-mounted disconnect devices, Class 9422TGI, or TG2 devices

Important Ordering Information

Depending on model, order as follows:

On SDN12PL, N412CD and N412CSTD Models

- Customer must order operating mechanism, operating handle, and disconnect switch or circuit breakers from the disconnect manufacturers (door handle and latching hardware included). See page G14 for ordering information.

On SDN12 and ABN12 V, U, C Models

- Customer must order operating mechanism and disconnect switch or circuit breakers, operating handle, and door hardware from the disconnect manufacturers (see page G14 for ordering information).

On SN4 and SSN4X Models

- Customer must order operating mechanism, operating handle and disconnect switch or circuit breakers, from the disconnect manufacturers (these models do NOT get door hardware). See page G15 for ordering information.

Wire Bend Space

- See pages G16-G22 for wire bend space available when various manufactures' disconnect switches are installed. Check the enclosure dimension drawings to verify the chosen disconnect switch will fit in the enclosure.

Note:

- E = 4.75 when Depth = 8.00
- E = 7.09 when Depth = 10.00
- E = 11.62 when Depth = 12.00 or 16.00
- E = 18.38 for SDN 12603812A
- WB = Wiring Space

See Pages G14 for various brands of disconnects for “F”, “G” & “WB” dimensions.

Disconnects will occupy space on panel shown by dimensions “E”, “F” & “G”. Wiring space “WB” is available when disconnect is installed in the enclosure.

Refer to National Electrical Code article 430-10(b) for wiring space required for line side conductors to be connected to disconnect. Verify your application to determine if wiring space is adequate.

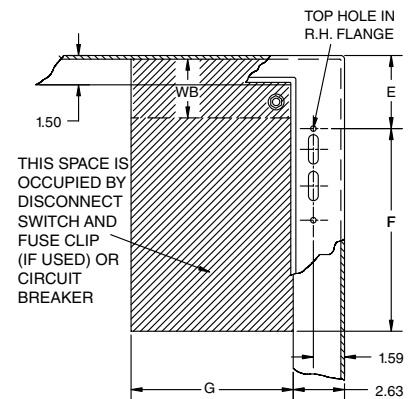

**Operator adapter plates are not required with these enclosures*

SDN12 & SDN12PL SERIES ENCLOSURES NEMA 12 FLANGED SINGLE DOOR DISCONNECT



SDN12-PL



SDN12

Industry Standards

UL 508A, Type 12 & 13

CSA Certified, Type 12

NEMA/EEMAC Type 12 & 13

 UL Files E64791

 CSA File LL66078

FEATURES-SPECIFICATIONS

Construction

- Bodies and doors are fabricated from carbon steel
- Seams are continuously welded and ground smooth
- Rolled lip around all sides of enclosure opening to exclude liquids and contaminants
- Door is removed by pulling continuous hinge pin
- Doors are sealed with a poured in place gasket
- External mounting feet are provided
- Collar studs for mounting **optional** back panels are provided
- Grounding provisions are provided
- Holes are provided in body and door for mounting operating handle,

operating mechanism, and door closing mechanism

- Interlocking door catch is provided
- Enclosures under 40" high require 2-point door hardware
- Enclosures 40" high and larger require 3-point door hardware
- Instructions to locate and install disconnect switches, circuit breakers, and operating mechanisms are provided
- Enclosures available with or without padlocking, defeater handle, and latching system

Finish

- ANSI 61 gray polyester powder inside and out
- **Optional** back panels are painted with a white polyester powder
- **Optional** "G" panels are pre-galvanized steel

Accessories

- Back panels (reference table)
- Blank Adapter Plates on page G60

IMPORTANT Ordering Information

- See page G14 for disconnect switch, circuit breakers, operating handle and operating mechanism.

SDN12 & SDN12PL SERIES ENCLOSURES NEMA 12 FLANGED SINGLE DOOR DISCONNECT

SDN12 & SDN12PL SERIES WALL-MOUNT DISCONNECT

Catalog Number		Enclosure Size HxWxD	Back Panel Catalog Number*		Back Panel Size AxB
With Handle	Without Handle		White	"G"	
SDN12202108PL	SDN12202108	20.00x21.38x8.10 (508x543x206)	NP2020	NP2020G	17.00x17.00 (432x432)
SDN12242108PL	SDN12242108	24.00x21.38x8.10 (610x543x206)	NP2420	NP2420G	21.00x17.00 (533x432)
SDN12242508PL	SDN12242508	24.00x25.38x8.10 (610x645x206)	NP2424	NP2424G	21.00x21.00 (533x533)
SDN12302108PL	SDN12302108	30.00x21.38x8.10 (762x543x206)	NP3020	NP3020G	27.00x17.00 (686x432)
SDN12302508PL	SDN12302508	30.00x25.38x8.10 (762x645x206)	NP3024	NP3024G	27.00x21.00 (686x533)
SDN12362508PL	SDN12362508	36.00x25.38x8.10 (914x645x206)	NP3624	NP3624G	33.00x21.00 (838x533)
SDN12363108PL	SDN12363108	36.00x31.38x8.10 (914x797x206)	NP3630	NP3630G	33.00x27.00 (838x686)
SDN12423208PL	SDN12423208	42.00x31.38x8.10 (1067x797x206)	NP4230	NP4230G	39.00x27.00 (991x686)
SDN12423708PL	SDN12423708	42.00x37.38x8.10 (1067x949x206)	NP4236	NP4236G	39.00x33.00 (991x838)
SDN12483708PL	SDN12483708	48.00x37.38x8.10 (1219x949x206)	NP4836	NP4836G	45.00x33.00 (1143x838)
SDN12603808PL	SDN12603808	60.00x37.38x8.10 (1524x949x207)	NP6036	NP6036G	57.00x33.00 (1448x838)
SDN12202110PL	SDN12202110	20.00x21.38x10.25 (508x543x257)	NP2020	NP2020G	17.00x17.00 (432x432)
SDN12242110PL	SDN12242110	24.00x21.38x10.25 (610x543x257)	NP2420	NP2420G	21.00x17.00 (533x432)
SDN12242510PL	SDN12242510	24.00x25.38x10.25 (610x645x257)	NP2424	NP2424G	21.00x21.00 (533x533)
SDN12302110PL	SDN12302110	30.00x21.38x10.25 (762x543x257)	NP3020	NP3020G	27.00x17.00 (686x432)
SDN12302510PL	SDN12302510	30.00x25.38x10.25 (762x645x257)	NP3024	NP3024G	27.00x21.00 (686x533)
SDN12362510PL	SDN12362510	36.00x25.38x10.25 (914x645x257)	NP3624	NP3624G	33.00x21.00 (838x533)
SDN12363110PL	SDN12363110	36.00x31.38x10.25 (914x797x257)	NP3630	NP3630G	33.00x27.00 (838x686)
SDN12423110PL	SDN12423110	42.00x31.38x10.25 (1067x797x257)	NP4230	NP4230G	39.00x27.00 (991x686)
SDN12423710PL	SDN12423710	42.00x37.38x10.25 (1067x949x257)	NP4236	NP4236G	39.00x33.00 (991x838)
SDN12483710PL	SDN12483710	48.00x37.38x10.25 (1219x949x257)	NP4836	NP4836G	45.00x33.00 (1143x838)
SDN12603710PL	SDN12603710	60.00x37.38x10.25 (1524x949x257)	NP6036	NP6036G	57.00x33.00 (1448x838)
SDN12302612PL	SDN12302612	30.00x25.38x12.13 (762x645x308)	NP3024	NP3024G	27.00x21.00 (686x533)
SDN12363212PL	SDN12363212	36.00x31.38x12.13 (914x797x308)	NP3630	NP3630G	33.00x27.00 (838x686)
SDN12423212PL	SDN12423212	42.00x31.38x12.13 (1067x797x308)	NP4230	NP4230G	39.00x27.00 (991x686)
SDN12423812PL	SDN12423812	42.00x37.38x12.13 (1067x949x308)	NP4236	NP4236G	39.00x33.00 (991x838)
SDN12483812PL	SDN12483812	48.00x37.38x12.13 (1219x949x308)	NP4836	NP4836G	45.00x33.00 (1143x838)
SDN12603812PL	SDN12603812	60.00x37.38x12.13 (1524x949x308)	NP6036	NP6036G	57.00x33.00 (1448x838)
SDN12603812APL	SDN12603812A**	60.00x37.38x12.13 (1524x949x308)	NP6036	NP6036G	57.00x33.00 (1448x838)
SDN12363116PL	SDN12363116	36.00x31.38x16.13 (914x797x410)	NP3630	NP3630G	33.00x27.00 (838x686)
SDN12483816PL	SDN12483816	48.00x37.38x16.13 (1219x949x410)	NP4836	NP4836G	45.00x33.00 (1143x838)
SDN12603816PL	SDN12603816	60.00x37.38x16.13 (1524x949x410)	NP6036	NP6036G	57.00x33.00 (1448x838)

* Back panels must be ordered separately.

** Enclosure catalog number SDN12603812A will receive only 400 amp and 600 amp Allen-Bradley 1494V disconnect switches and Siemens ITE Max-Flex® 800 amp and 1200 amp circuit breakers. The 400 amp and 600 amp Allen-Bradley disconnect switch will not fit any other size enclosure from the SDN12 family. Blank Adapter plates will not fit catalog number SDN12603812A. Enclosures 12" and 16" deep can be modified to accept Siemens ITE Max-Flex® 800 amp and 1200 amp circuit breakers. (When using a Siemens ITE Max-Flex® circuit breaker and an enclosure with an "H" dimension of 30", 36" or 42", verify the amount of wire bend space required for both the line and load sides.) Consult factory for details.

**SDN12 & SDN12PL SERIES ENCLOSURES
NEMA 12 FLANGED SINGLE DOOR DISCONNECT**

G5

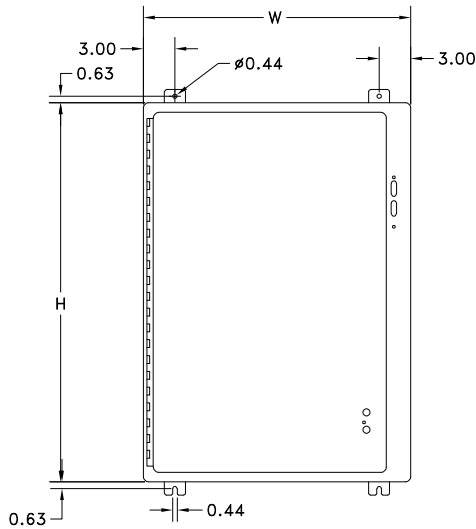

SDN12

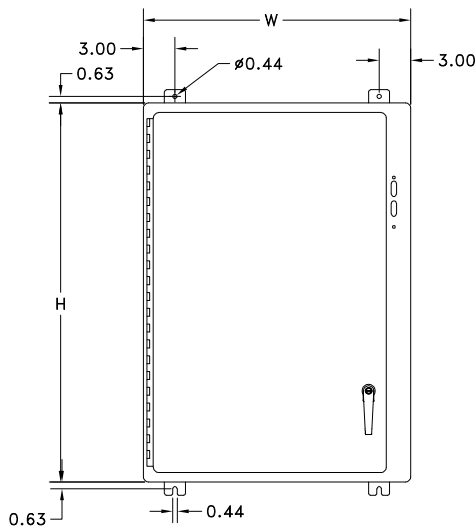
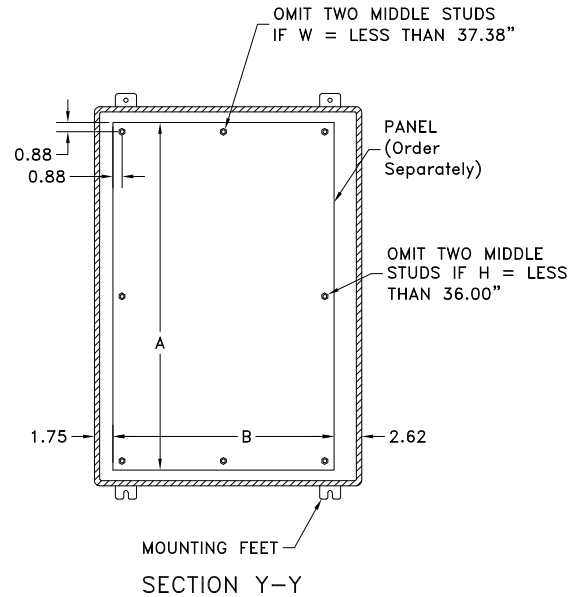

SDN12-PL

PADLOCKABLE
HANDLE INSTALLED

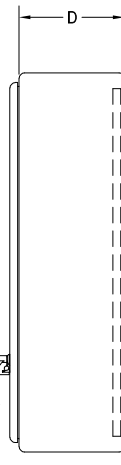

Note:

- E = 4.75 when D = 8.00
- E = 7.09 when D = 10.00
- E = 11.62 when D = 12.00 or 16.00
- E = 18.38 for SDN12603812A

See Pages F9-F15 for various brands of disconnects for "F", "G", & "WB" dimensions.

Disconnects will occupy space on panel shown by dimensions "E", "F", & "G". Wiring space "WB" is available when disconnect is installed in the enclosure.

Refer to National Electrical Code 1996 article 430-10(b) for wiring space required for line side conductors to be connected to disconnect. Verify your application to determine if wiring space is adequate.

THIS SPACE IS OCCUPIED
BY DISCONNECT SWITCH
AND FUSE CLIP (IF USED)
OR CIRCUIT BREAKER.

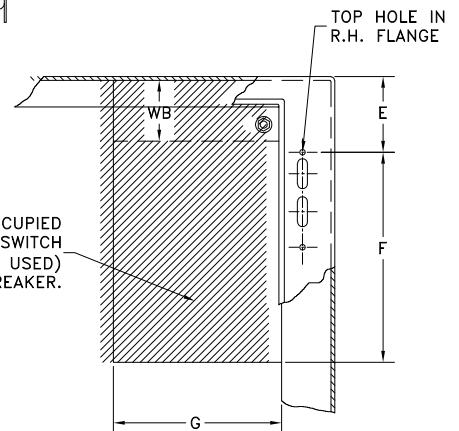



Industry Standards

UL 508A, Type 3R, 4, 4X, 12 & 13
CSA Certified, Type 3R, 4, 4X, 12 & 13
NEMA/EEMAC Type 3R, 4, 4X, 12 & 13
Wall mounting kits are required to maintain UL/CSA external mounting requirements
IEC 60529, IP66

 UL Files E64791, E470978

 CSA File LL66078

FEATURES-SPECIFICATIONS

Construction

- Bodies and doors are fabricated from carbon steel or 304/316L stainless steel
- Seams are continuously welded and ground smooth
- Increased tub opening for better access
- Concealed hinges
- Doors are interchangeable and easily removed
- Grounding provisions are provided
- Doors are sealed with a poured in place gasket
- Mounting holes in the back of the enclosure

- Studs for mounting **optional** back panels are provided
- Door handle contains a slotted insert defeater mechanism
- Latching system interlocks with the disconnect handle for added safety
- 2-point latch system up to 36" in height and 3-point latch system on enclosures 42" and higher

Finish

- ANSI 61 gray polyester powder inside and out
- Stainless steel enclosures have a smooth grained finish
- **Optional** back panels are painted with a white polyester powder
- **Optional** "G" panels are pre-galvanized steel

Accessories

- Back panels (reference table)
- Blank Adapter Plates on page G60

IMPORTANT Ordering Information

- See page G14 for disconnect switch, circuit breakers, operating handle and operating mechanism.

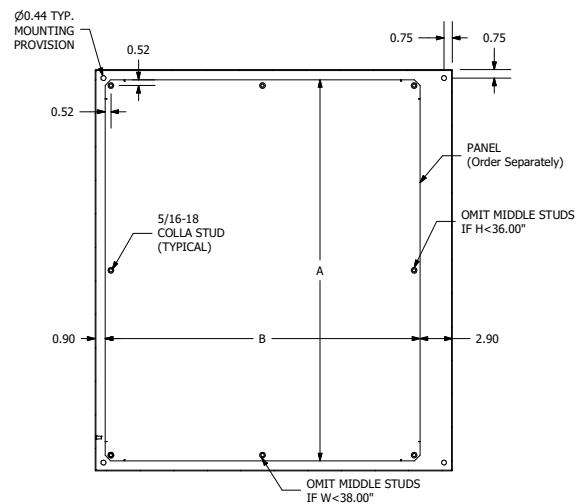
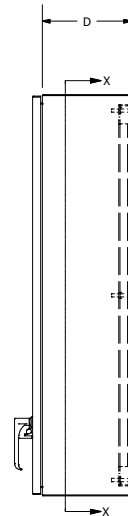
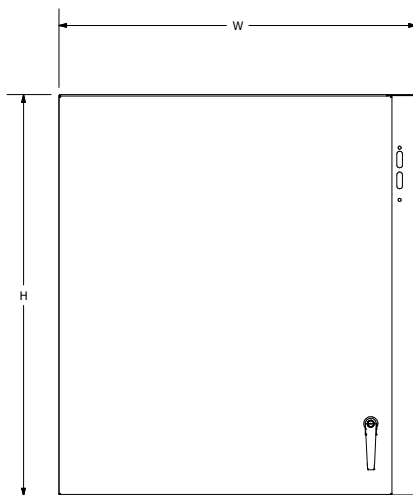

SECTION X-X

N412-CD N412-CDSS ULTIMATE SERIES ENCLOSURES NEMA 412 SINGLE DOOR FLANGED DISCONNECT

G7

N412CD ULTIMATE SERIES WALL-MOUNT DISCONNECT CARBON STEEL

Catalog Number	Enclosure Size HxWxD	Back Panel Catalog Number*		Back Panel Size AxB
		White	"G"	
N412202208CD	20.00 x 22.00 x 8.00 (508 x 559 x 203)	NP2020C	NP2020CG	18.2 x 18.2 (462 x 462)
N412242208CD	24.00 x 22.00 x 8.00 (610 x 559 x 203)	NP2420C	NP2420CG	22.2 x 18.2 (564 x 462)
N412242608CD	24.00 x 26.00 x 8.00 (610 x 660 x 203)	NP2424C	NP2424CG	22.2 x 22.2 (564 x 564)
N412302608CD	30.00 x 26.00 x 8.00 (762 x 660 x 203)	NP3024C	NP3024CG	28.2 x 22.2 (716 x 564)
N412362608CD	36.00 x 26.00 x 8.00 (914 x 660 x 203)	NP3624C	NP3624CG	34.2 x 22.2 (869 x 564)
N412363208CD	36.00 x 32.00 x 8.00 (914 x 813 x 203)	NP3630C	NP3630CG	34.2 x 28.2 (869 x 716)
N412423212CD	42.00 x 32.00 x 12.00 (1067 x 813 x 305)	NP4230C	NP4230CG	40.2 x 28.2 (1021 x 716)
N412423812CD	42.00 x 38.00 x 12.00 (1067 x 965 x 305)	NP4236C	NP4236CG	40.2 x 34.2 (1021 x 869)
N412483812CD	48.00 x 38.00 x 12.00 (1219 x 965 x 305)	NP4836C	NP4836CG	46.2 x 34.2 (1173 x 869)
N412603812CD	60.00 x 38.00 x 12.00 (1524 x 965 x 305)	NP6036C	NP6036CG	58.2 x 34.2 (1478 x 869)

N412CDSS ULTIMATE SERIES WALL-MOUNT DISCONNECT 304 STAINLESS STEEL

Catalog Number	Enclosure Size HxWxD	Back Panel Catalog Number*		Back Panel Size AxB
		White	"G"	
N412202208CDSS	20.00 x 22.00 x 8.00 (508 x 559 x 203)	NP2020C	NP2020CG	18.2 x 18.2 (462 x 462)
N412242208CDSS	24.00 x 22.00 x 8.00 (610 x 559 x 203)	NP2420C	NP2420CG	22.2 x 18.2 (564 x 462)
N412242608CDSS	24.00 x 26.00 x 8.00 (610 x 660 x 203)	NP2424C	NP2424CG	22.2 x 22.2 (564 x 564)
N412302608CDSS	30.00 x 26.00 x 8.00 (762 x 660 x 203)	NP3024C	NP3024CG	28.2 x 22.2 (716 x 564)
N412362608CDSS	36.00 x 26.00 x 8.00 (914 x 660 x 203)	NP3624C	NP3624CG	34.2 x 22.2 (869 x 564)
N412363208CDSS	36.00 x 32.00 x 8.00 (914 x 813 x 203)	NP3630C	NP3630CG	34.2 x 28.2 (869 x 716)
N412423212CDSS	42.00 x 32.00 x 12.00 (1067 x 813 x 305)	NP4230C	NP4230CG	40.2 x 28.2 (1021 x 716)
N412423812CDSS	42.00 x 38.00 x 12.00 (1067 x 965 x 305)	NP4236C	NP4236CG	40.2 x 34.2 (1021 x 869)
N412483812CDSS	48.00 x 38.00 x 12.00 (1219 x 965 x 305)	NP4836C	NP4836CG	46.2 x 34.2 (1173 x 869)
N412603812CDSS	60.00 x 38.00 x 12.00 (1524 x 965 x 305)	NP6036C	NP6036CG	58.2 x 34.2 (1478 x 869)

N412CDSSA ULTIMATE SERIES WALL-MOUNT DISCONNECT 316L STAINLESS STEEL

Catalog Number	Enclosure Size HxWxD	Back Panel Catalog Number*		Back Panel Size AxB
		White	"G"	
N412202208CDSSA	20.00 x 22.00 x 8.00 (508 x 559 x 203)	NP2020C	NP2020CG	18.2 x 18.2 (462 x 462)
N412242208CDSSA	24.00 x 22.00 x 8.00 (610 x 559 x 203)	NP2420C	NP2420CG	22.2 x 18.2 (564 x 462)
N412242608CDSSA	24.00 x 26.00 x 8.00 (610 x 660 x 203)	NP2424C	NP2424CG	22.2 x 22.2 (564 x 564)
N412302608CDSSA	30.00 x 26.00 x 8.00 (762 x 660 x 203)	NP3024C	NP3024CG	28.2 x 22.2 (716 x 564)
N412362608CDSSA	36.00 x 26.00 x 8.00 (914 x 660 x 203)	NP3624C	NP3624CG	34.2 x 22.2 (869 x 564)
N412363208CDSSA	36.00 x 32.00 x 8.00 (914 x 813 x 203)	NP3630C	NP3630CG	34.2 x 28.2 (869 x 716)
N412423212CDSSA	42.00 x 32.00 x 12.00 (1067 x 813 x 305)	NP4230C	NP4230CG	40.2 x 28.2 (1021 x 716)
N412423812CDSSA	42.00 x 38.00 x 12.00 (1067 x 965 x 305)	NP4236C	NP4236CG	40.2 x 34.2 (1021 x 869)
N412483812CDSSA	48.00 x 38.00 x 12.00 (1219 x 965 x 305)	NP4836C	NP4836CG	46.2 x 34.2 (1173 x 869)
N412603812CDSSA	60.00 x 38.00 x 12.00 (1524 x 965 x 305)	NP6036C	NP6036CG	58.2 x 34.2 (1478 x 869)

*Back panels must be ordered separately.

N412-CSTD & N412-CSSSTD SLOPE-TOP FLANGED DISCONNECT ULTIMATE SERIES ENCLOSURES



N412242608CSSSTD

Industry Standards

UL 508A, Type 3R, 4, 4X, 12 & 13
CSA Certified, Type 3R, 4, 4X, 12 & 13
NEMA/EEMAC Type 3R, 4, 4X, 12 & 13
Wall mounting kits are required to
maintain UL/CSA external mounting
requirements
IEC 60529, IP66

 UL File E64791

 CSA File LL66078

FEATURES-SPECIFICATIONS

Applications

N412CDTD & N412CSSSTD Ultimate Series Disconnects are designed to house and protect electrical and electronic components in harsh, dirty environments. For use in installations where dirt, dust, oil, water or other contaminants are present. Streamlined styling, latching, and attractive durable finish complements any high tech electronic equipment.

Construction

- Bodies and doors are fabricated from carbon steel or 304 stainless steel
- Seams are continuously welded and ground smooth
- Increased tub opening for better access
- 20 Degree sloped top
- Sloped "Top Tub Flange"

- Concealed hinges
- Doors are interchangeable and easily removed
- Grounding provisions are provided
- Door handle contains a slotted insert defeater mechanism
- Doors are sealed with a poured in place gasket
- Mounting holes in the back of the enclosure are provided
- Studs for mounting **optional** Ultimate Series back panels are provided
- Door handle and latching hardware are provided
- Latching system interlocks with the disconnect handle for added safety
- 2-point latch system up to 36" in height and 3-point latch system on enclosures 42" and higher

Finish

- ANSI 61 gray polyester powder inside and out
- Stainless steel enclosures have a smooth grained finish
- **Optional** back panels are painted with a white polyester powder
- **Optional** "G" are panels pre-galvanized steel

Accessories

- Back panels (reference table)
- See pages L1-L24

IMPORTANT Ordering Information

- See G14 for disconnect switch, circuit breakers, operating handle and operating mechanism.

N412CSTD & N412CSSTD ULTIMATE SERIES ENCLOSURES SLOPE-TOP SINGLE DOOR FLANGED DISCONNECT

G9

N412-CSTD ULTIMATE SERIES SLOPE-TOP SINGLE DOOR DISCONNECT

Catalog Number	Enclosure Size HxWxD	Back Panel Catalog Number*		Back Panel Size AxB
		White	"G"	
N412202208CSTD	20.00 x 22.00 x 8.00 (508 x 559 x 203)	NP2020C	NP2020CG	18.2 x 18.2 (462 x 462)
N412242208CSTD	24.00 x 22.00 x 8.00 (610 x 559 x 203)	NP2420C	NP2420CG	22.2 x 18.2 (564 x 462)
N412242608CSTD	24.00 x 26.00 x 8.00 (610 x 660 x 203)	NP2424C	NP2424CG	22.2 x 22.2 (564 x 564)
N412302608CSTD	30.00 x 26.00 x 8.00 (762 x 660 x 203)	NP3024C	NP3024CG	28.2 x 22.2 (716 x 564)
N412363210CSTD	36.00 x 32.00 x 10.00 (914 x 660 x 203)	NP3630C	NP3630CG	34.2 x 28.2 (869 x 716)
N412423212CSTD	42.00 x 32.00 x 12.00 (1067 x 813 x 305)	NP4230C	NP4230CG	40.2 x 28.2 (1021 x 716)
N412483812CSTD	48.00 x 38.00 x 12.00 (1219 x 965 x 305)	NP4836C	NP4836CG	46.2 x 34.2 (1173 x 869)
N412603812CSTD	60.00 x 38.00 x 12.00 (1524 x 965 x 305)	NP6036C	NP6036CG	58.2 x 34.2 (1478 x 869)

N412-CSSSTD ULTIMATE SERIES SLOPE-TOP SINGLE DOOR DISCONNECT

Catalog Number	Enclosure Size HxWxD	Back Panel Catalog Number*		Back Panel Size AxB
		White	"G"	
N412242608CSSSTD	24.00 x 26.00 x 8.00 (610 x 660 x 203)	NP2424C	NP2424CG	22.2 x 22.2 (564 x 564)
N412302608CSSSTD	30.00 x 26.00 x 8.00 (762 x 660 x 203)	NP3024C	NP3024CG	28.2 x 22.2 (716 x 564)
N412363208CSSSTD	36.00 x 32.00 x 8.00 (914 x 660 x 203)	NP3630C	NP3630CG	34.2 x 28.2 (869 x 716)
N412483816CSSSTD	48.00 x 38.00 x 16.00 (1219 x 965 x 305)	NP4836C	NP4836CG	46.2 x 34.2 (1173 x 869)
N412603816CSSSTD	60.00 x 38.00 x 16.00 (1524 x 965 x 305)	NP6036C	NP6036CG	58.2 x 34.2 (1478 x 869)

*Back panels must be ordered separately.

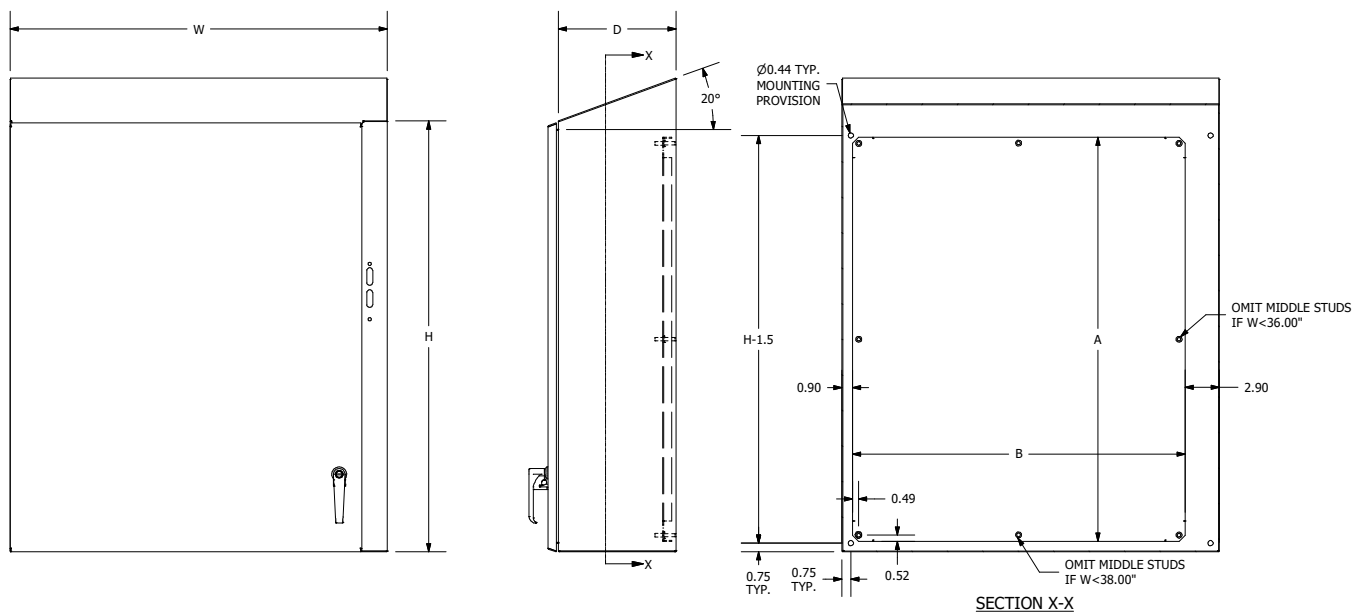

SN4 SERIES ENCLOSURES NEMA 4 SINGLE DOOR FLANGED DISCONNECT



SN4242108

Industry Standards

UL 508A, Type 4, 12, & 13
CSA Certified, Type 4 & 12
NEMA/EEMAC Type 4, 12, & 13

 UL File E64791

 CSA File LL66078

FEATURES-SPECIFICATIONS

Construction

- Bodies and doors are fabricated from carbon steel
- Seams are continuously welded and ground smooth
- Rolled lip around all sides of the enclosure opening to exclude liquids and contaminants
- All exterior hardware is stainless steel
- Stainless steel door clamps are provided around three sides of the door for a water-tight seal. Additional door hardware is not required
- Doors are easily removed by pulling continuous hinge pin

- Doors are sealed with a poured in place gasket
- External mounting feet are provided
- Collar studs for mounting **optional** back panels are provided
- Grounding provisions are provided
- Interlock door catch is provided
- Holes provided in body for mounting disconnect operating handle and operating mechanism. These enclosures are designed to operate properly without the use of door hardware

Finish

- ANSI 61 gray polyester powder inside and out
- **Optional** back panels are painted with a white polyester powder
- **Optional** "G" panels are pre-galvanized steel

Accessories

- Back panels (reference table)
- Blank Adapter Plates on page G60

IMPORTANT Ordering Information

- See page G15 for disconnect switch, circuit breakers, operating handle and operating mechanism.

SN4 SERIES WALL-MOUNT DISCONNECT

Catalog Number	Enclosure Size HxWxD	Back Panel Catalog Number*		Back Panel Size AxB
		White	"G"	
SN4242108	24.00x21.38x8.13 (610x543x207)	NP2420	NP2420G	21.00x17.00 (533x432)
SN4242508	24.00x25.38x8.13 (610x645x207)	NP2424	NP2424G	21.00x21.00 (533x533)
SN4302508	30.00x25.38x8.13 (762x645x207)	NP3024	NP3024G	27.00x21.00 (686x533)
SN4363108	36.00x31.38x8.13 (914x797x207)	NP3630	NP3630G	33.00x27.00 (838x686)
SN4423112	42.00x31.38x12.13 (1067x797x308)	NP4230	NP4230G	39.00x27.00 (991x686)
SN4423712	42.00x37.38x12.13 (1067x949x308)	NP4236	NP4236G	39.00x33.00 (991x838)
SN4483712	48.00x37.38x12.13 (1219x949x308)	NP4836	NP4836G	45.00x33.00 (1143x838)
SN4603712	60.00x37.38x12.13 (1524x949x308)	NP6036	NP6036G	57.00x33.00 (1448x838)

*Back panels must be ordered separately

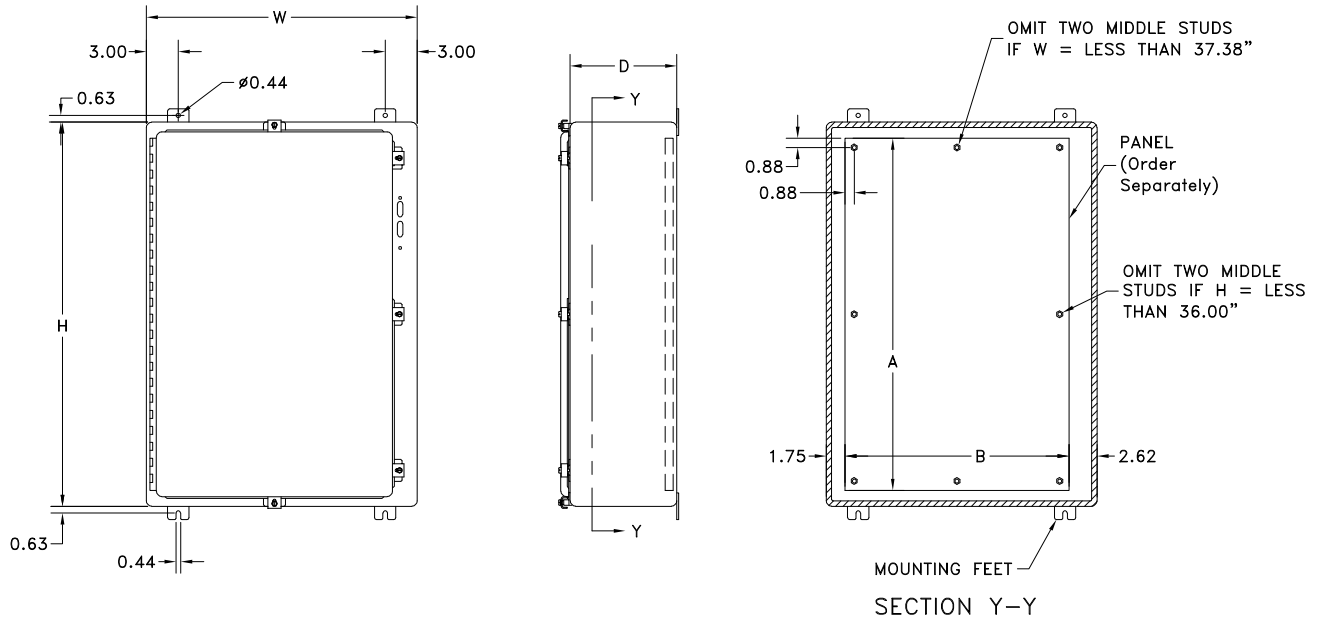

Space Occupied by Disconnect

- E = 8.63 when D = 8.00
- E = 10.13 when D = 10.00
- E = 11.62 when D = 12.00
- WB = Wiring Space

See pages F9-F15 for various brands of disconnects for "F", "G", & "WB" dimensions.

Disconnects will occupy space on panel shown by dimensions "E", "F", & "G". Wiring space "WB" is available when disconnect is installed in the enclosure.

Refer to National Electrical Code 1996 article 430-10(b) for wiring space required for line side conductors to be connected to disconnect. Verify your application to determine if wiring space is adequate.

THIS SPACE IS OCCUPIED BY DISCONNECT SWITCH AND FUSE CLIP (IF USED) OR CIRCUIT BREAKER.

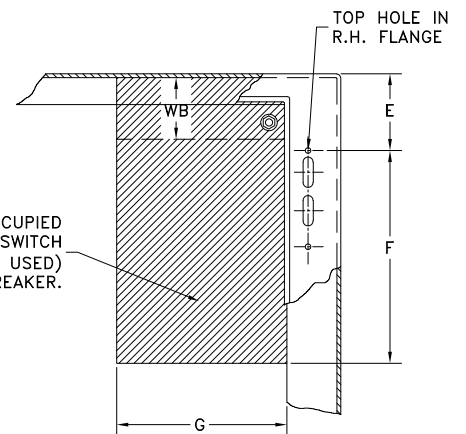

SSN4X SERIES ENCLOSURES NEMA 4X SINGLE DOOR FLANGED DISCONNECT



SSN4X242108

Industry Standards

UL 508A, Types 3R 4, 4X, 12, & 13

CSA Certified, Types 4X & 12

NEMA/EEMAC Types 3R, 4, 4X, 12, & 13



UL File E64791



CSA File LL66078

FEATURES-SPECIFICATIONS

Construction

- Bodies and doors are fabricated from 304 or 316L stainless steel
- Seams are continuously welded and ground smooth
- Rolled lip around all sides of the enclosure opening to exclude liquids and contaminants
- Stainless steel door clamps are provided around three sides of the door for a water-tight seal. Additional door hardware is not required
- Doors are easily removed by pulling stainless steel continuous hinge pin

- Doors are sealed with a poured in place gasket
- External mounting feet are provided
- Collar studs for mounting **optional** back panels are provided
- Grounding provisions are provided
- Interlock door catch is provided
- Holes are provided in body for mounting disconnect operating handle and operating mechanism. These enclosures are designed to operate properly without the use of door hardware

Finish

- Exterior surfaces of the enclosure have a smooth grained finish
- **Optional** back panels are painted with a white polyester powder
- **Optional** "G" panels are pre-galvanized steel
- **Optional** 304SS panels are made of 304 stainless steel

Accessories

- Back panels (reference table)
- Blank Adapter Plates on page G60

IMPORTANT Ordering Information

- See page G15 for disconnect switch, circuit breakers, operating handle and operating mechanism

SSN4X SERIES STAINLESS STEEL WALL-MOUNT DISCONNECT

Catalog Number		Enclosure Size HxWxD	Back Panel Catalog Number*			Back Panel Size AxB
304	316L		White	304 SS	"G"	
SSN4X242108	SSN4X242108A	24.00x21.38x8.13 (610x543x207)	NP2420	NP2420SS	NP2420G	21.00x17.00 (533x432)
SSN4X242508	SSN4X242508A	24.00x25.38x8.13 (610x645x207)	NP2424	NP2424SS	NP2424G	21.00x21.00 (533x533)
SSN4X302508	SSN4X302508A	30.00x25.38x8.13 (762x645x207)	NP3024	NP3024SS	NP3024G	27.00x21.00 (686x533)
SSN4X362508	SSN4X362508A	36.00x25.38x8.13 (914x645x207)	NP3624	NP3624SS	NP3624G	33.00x21.00 (838x533)
SSN4X363108	SSN4X363108A	36.00x31.38x8.13 (914x797x207)	NP3630	NP3630SS	NP3630G	33.00x27.00 (838x686)
SSN4X423112	SSN4X423112A	42.00x31.38x12.13 (1067x797x308)	NP4230	NP4230SS	NP4230G	39.00x27.00 (991x686)
SSN4X423712	SSN4X423712A	42.00x37.38x12.13 (1067x949x308)	NP4236	NP4236SS	NP4236G	39.00x33.00 (991x838)
SSN4X483712	SSN4X483712A	48.00x37.38x12.13 (1219x949x308)	NP4836	NP4836SS	NP4836G	45.00x33.00 (1143x838)
SSN4X603712	SSN4X603712A	60.00x37.38x12.13 (1524x949x308)	NP6036	NP6036SS	NP6036G	57.00x33.00 (1448x838)

*Back panels must be ordered separately.

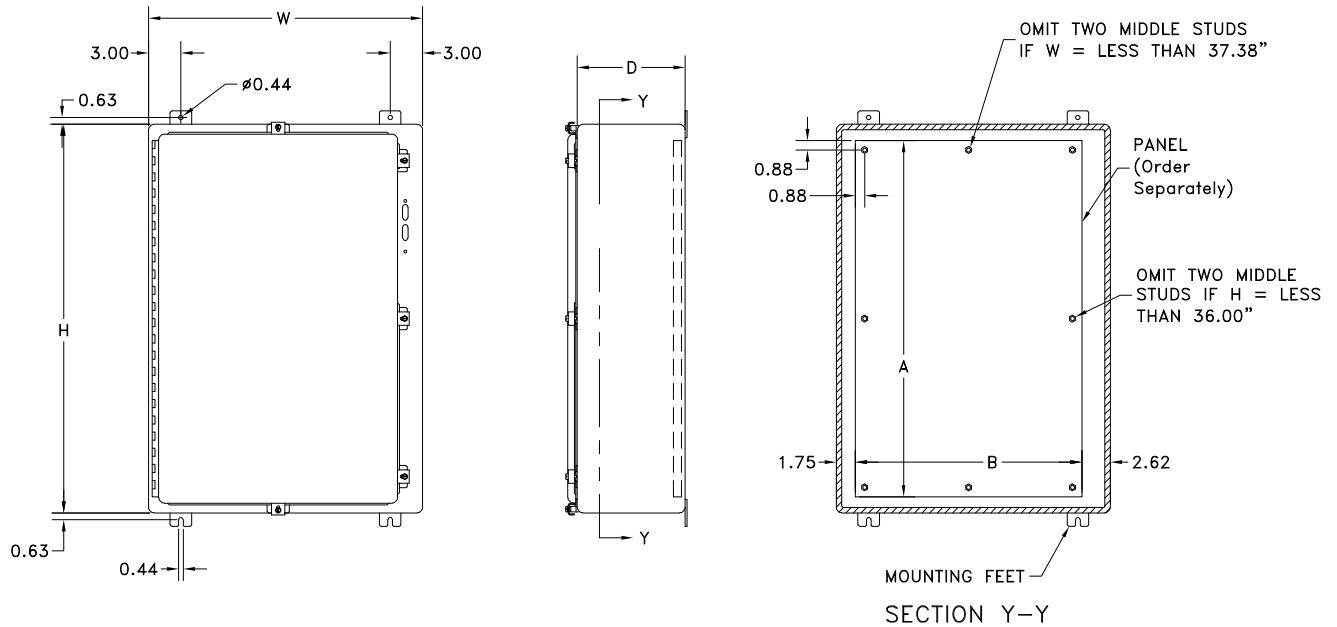

Space Occupied by Disconnect

- E = 8.63 when D = 8.00
- E = 10.13 when D = 10.00
- E = 11.62 when D = 12.00
- WB = Wiring Space

See pages F9-F15 for various brands of disconnects for "F", "G", & "WB" dimensions.

Disconnects will occupy space on panel shown by dimensions "E", "F", & "G". Wiring space "WB" is available when disconnect is installed in the enclosure.

Refer to National Electrical Code 1996 article 430-10(b) for wiring space required for line side conductors to be connected to disconnect. Verify your application to determine if wiring space is adequate.

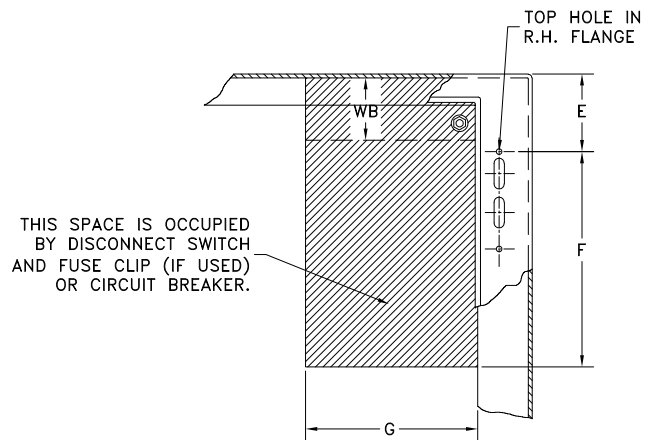

DISCONNECT ORDERING INFORMATION

When ordering wall-mounted disconnects from the various manufacturers, be sure to order all of the necessary items. Each company has a different system, so care is required. Order the following items from the disconnect manufacturer. or FH-DHK and FH-3RL for 3-point latching)

Allen-Bradley

- 1494V disconnect switches with flange-mount variable depth operating mechanisms and 1494V flange-mounted variable depth operating mechanisms for circuit breakers
- 140U flexible cable operating mechanisms and 140U molded case circuit breakers
- 1494C cable-operated disconnect switches with flange-mount handles
- 194RC cable-operated flange-mount handles for use with the NFPA 79 compliant 194R IEC rotary disconnect switches

Allen-Bradley 1494V-R1, -R2 and -W2 operating handles and Allen-Bradley 1494F disconnect devices or 1494D circuit breaker operators will NOT fit these enclosures.

When using a Bulletin 1494V disconnect switch, order:

- * 1. A disconnect switch with operating mechanism (Bulletin 1494V)
- * 2. Bulletin 1494-H1 operating handle (Use Bulletin 1494-H2 for enclosure catalog number SDN12603812A)
- * 3. A connecting rod [Bulletin 1494V-RA1 for 8.00" (203mm) and 10.00" (254mm) deep enclosures; Bulletin 1494V-RA2 for 12.00" (305mm) and 16.00" (406mm) deep enclosures; two of Bulletin 1494-RB2 for 400 amp or 600 amp switch in a SDN12603812A]
- * 4. A trailer fuse block kit, if required (Bulletin 1494V)
- * 5. A fuse clip kit, if required
- 6. Line and load connectors, if required
- ** 7. Door hardware (Bulletin 1494V-L1 for 2-point latching or Bulletin 1494V-L1 and 1494V-L2 for 3-point door latching)

When using a Bulletin 1494V circuit breaker operating mechanism, order:

- 1. A circuit breaker (C-H)
- 2. A circuit breaker operating mechanism (Bulletin 1494V)
- 3. An operating handle (Bulletin 1494V-H11)
- 4. A connecting rod [Bulletin 1494V-RA1 for 8.00" (203mm) and 10.00" (254mm) deep enclosures or Bulletin 1494V-RA2 for 12.00" (305mm) and 16.00" (406mm) deep enclosures]
- ** 5. Door hardware (Bulletin 1494V-L1 for 2-point latching or Bulletin 1494V-L1 and 1494V-L2 for 3-point door latching)

Allen-Bradley 1494 F Series See G23-G26

ABB Controls

When using a disconnect switch, order:

- 1. A flange operated switch (fusible or non-fusible)
- 2. A shaft [DSFHS-12 for 8.00" (203mm), 10.00" (254mm) and 12.00" (305mm) deep enclosures or DSFHS-17 for 16.00" (406mm) deep enclosures]
- 3. A handle (DSFGN-HS12)
- ** 4. Door hardware (FH-DHK for 2-point latching or FH-DHK and FH-3RL for 3-point latching)

When using a circuit breaker, order:

- 1. A circuit breaker (ABB)
- * 2. An operating mechanism
- * 3. A shaft [FHS-12 for 8.00" (203mm), 10.00" (254mm) and 12.00" (305mm) deep enclosures or FHS-17 for 16.00" (406mm) deep enclosures]
- * 4. Handle mechanism (FHN-HS12)
- ** 5. Door hardware (FH-DHK for 2-point latching

Eaton Cutler-Hammer

When using a Type C361 disconnect switch, order:

- * 1. A disconnect switch with an operating mechanism
- * 2. An operating handle (C361H1 or C361H3)
- ** 3. Door hardware (C361KJ4 or C361KJ6 for 2-point latching, C361KJ4 or C361KJ6 and C361KR for 3-point latching)

When using a Type C371 circuit breaker operating mechanism with a C-H circuit breaker, order:

- 1. A circuit breaker
- * 2. An operating mechanism
- * 3. An operating handle
- ** 4. Door hardware (C361KJ4 or C361KJ6 for 2-point latching, C361KJ4 or C361KJ6 and C361KR for 3-point latching)

When using a C-H circuit breaker with a Flex Shaft™ handle mechanism, order:

- 1. A circuit breaker
- 2. A complete Flex Shaft™ handle mechanism
- ** 3. Door hardware (C361KJ4 or C361KJ6 for 2-point latching, C361KJ4 or C361KJ6 and C361KR for 3-point latching)

General Electric

When using a disconnect switch, order:

- 1. A disconnect switch (Type QMR or QMW)
- 2. A fuse clip kit or no-fuse kit
- 3. A flange handle (STDA1 or STDA2)
- 4. A variable depth operating mechanism
- ** 5. Door hardware (TDV1 for 2-point latching or TDV1 and TDV3 for 3-point latching)

When using a circuit breaker with a Spectra Flex™ cable operator, order:

- 1. A circuit breaker
- 2. A flange-mounted handle mechanism
- 3. A breaker-mounted mechanism
- 4. An operating cable
- ** 5. Door hardware (TDV1 for 2-point latching or TDV1 and TDV3 for 3-point latching)

When using a circuit breaker, order:

- 1. A circuit breaker
- 2. A flange handle (STDA1 or STDA2)
- 3. A variable depth operating mechanism
- ** 4. Door hardware (TDV1 for 2-point latching or TDV1 and TDV3 for 3-point latching)

Siemens I-T-E Max-Flex™

When using a disconnect switch, order:

- 1. A basic switch (right-hand)
- 2. A fuse or no-fuse kit
- * 3. FHOHS flange-mounted handle
- * 4. Switch operator
- * 5. Cable, 36"
- ** 6. Door hardware (DKR2 for 2-point latching or DKR3 for 3-point latching)

NOTE: Some I-T-E fixed depth switch operators can be used. Contact Hubbell/Wiegmann for more information.

When using a circuit breaker, order:

- 1. A circuit breaker
- 2. Pressure wire connectors
- * 3. FHOH flange-mounted handle (Use FHOHN for enclosure catalog number SDN12603812A)

Siemens ITE Max-Flex™ (cont.)

- * 4. A circuit breaker operator mechanism
- * 5. An operating cable (standard 36.00" for 125 amp to 600 amp circuit breakers, and 48.00" for 800 amp to 1200 amp circuit breakers)
- ** 6. Door hardware (DKR2 for 2-point latching or DKR2 for 3-point latching)

Schneider Square D®

When using a Class 9422 disconnect switch, order:

- * 1. A disconnect switch with operating mechanism (Class 9422)
- * 2. A handle mechanism (Class 9422 Type A-1)
- ** 3. A door closing mechanism (Class 9423 Type M4 for 2-point latching, or Class 9423 Type M9 or M4 and Class 9423 Type M3 for 3-point latching)

When using a circuit breaker, order:

- 1. A circuit breaker (Schneider Square D®)
- * 2. An operating mechanism (Class 9422)
- * 3. A handle mechanism (Class 9422 Type A-1)
- ** 4. A door closing mechanism (Class 9423 Type M4 for 2-point latching, or Class 9423 Type M9 or M4 and Class 9423 Type M3 for 3-point latching)

When using a Class 9422 Type "T" disconnect switch with a cable mechanism, order:

- 1. A disconnect switch with operating mechanism (Class 9422, Type T)
- 2. A handle mechanism (Class 9422, Type A-1)
- 3. A cable mechanism (Class 9422, CFT_O) 3-, 5-, or 10-foot
- ** 4. A door closing mechanism (Class 9423 Type M4 for 2-point latching, or Class 9423 Type M9 or M4 and Class 9423 Type M3 for 3-point latching)

When using a circuit breaker with a cable mechanism, order:

- 1. A circuit breaker (Schneider Square D®)
- 2. A handle mechanism (Class 9422, Type A-1)
- 3. A cable mechanism (Class 9422, CFT_O) 3-, 5-, or 10-foot
- ** 4. A door closing mechanism (Class 9423 Type M4 for 2-point latching, or Class 9423 Type M9 or M4 and Class 9423 Type M3 for 3-point latching)

** Items available from disconnect manufacturer as complete kits.*

*** Enclosure "A" dimension less than 40.00" (1016mm) requires a 2-point door closing mechanism. Enclosures with an "A" dimension of 40.00" or more require a 3-point latching mechanism.*

PLEASE NOTE:

1. Operator adapter plates are not required with enclosures on page G2-G13.
2. Various other switch accessories and circuit breaker accessories are available from disconnect manufacturers. The information is subject to change without notice. Please contact Hubbell/Wiegmann or the disconnect manufacturer if there are further questions.
3. The "Space Occupied" tables (pages G16-G22) are based upon information supplied by disconnect manufacturers. Hubbell/Wiegmann does not assume responsibility for the accuracy of these dimensions.
4. Check to make certain enclosure size is adequate for disconnect mechanisms and wire bend space both above line lugs and below load lugs.

DISCONNECT ORDERING INFORMATION

When ordering wall-mounted disconnects from the various manufacturers, be sure to order all of the necessary items. Each company has a different system, so care is required. Order the following items from the disconnect manufacturer.

Use a Type 4 & 4X disconnect operating handle on the enclosure flange to provide corrosion resistance and maintain enclosure rating.

Allen-Bradley

When using a Bulletin 1494V disconnect switch, order:

1. A disconnect switch with operating mechanism (Bulletin 1494V)
2. An operating handle (Bulletin 1494V-W1)
3. A connecting rod [Bulletin 1494V-RA1 for 8.00" (203mm) deep enclosures; Bulletin 1494V-RA2 for 12.00" (305mm) deep enclosures]
4. A trailer fuse block kit, if required (Bulletin 1494V)
5. A fuse clip kit, if required
6. Line and load connectors, if required

When using a Bulletin 1494V circuit breaker operating mechanism, order:

1. A circuit breaker (C-H)
2. A circuit breaker operating mechanism (Bulletin 1494V)
3. An operating handle (Bulletin 494V-W11)
4. A connecting rod [Bulletin 1494V-RA1 for 8.00" (203mm) deep enclosures; Bulletin 1494V-RA2 for 12.00" (305mm) deep enclosures]

ABB Controls

When using a disconnect switch, order:

1. A flange operated switch (fusible or non-fusible)
2. A shaft [DSFHS-12]
3. A handle (DSFHN-HS4)

When using a circuit breaker, order:

1. A circuit breaker (ABB)
2. An operating mechanism
3. A shaft [FHS-12]
4. A handle (FHN-HS4)

Eaton Cutler-Hammer

PLEASE NOTE:

1. Operator adapter plates and door hardware are not required with enclosures on page G2-G13.
2. Various other switch accessories and circuit breaker accessories are available from disconnect manufacturers. The above information is subject to change without notice. Please contact Hubbell-Wiegmann or the disconnect manufacturer if there are further questions.
3. The "Space Occupied" tables (pages G16-G22) are based upon information supplied by disconnect manufacturers. Hubbell-Wiegmann does not assume responsibility for the accuracy of these dimensions.

When using a Type C361 disconnect switch, order:

1. A disconnect switch with an operating mechanism
2. An operating handle (C361H2 or C361H4)

When using a Type C371 circuit breaker operating mechanism with a C-H circuit breaker, order:

1. A circuit breaker
2. An operating mechanism
3. An operating handle (C371H2 or C371H4)

When using a C-H circuit breaker with a Type 4/4X Flex Shaft™ handle mechanism, order:

1. A circuit breaker
2. A complete Flex Shaft™ handle mechanism

General Electric

When using a disconnect switch, order:

1. A disconnect switch (Type QMR or QMW)
2. A fuse clip kit or no-fuse kit
3. A flange handle (STDA1X)
4. A variable depth operating mechanism

When using a circuit breaker, order:

1. A circuit breaker
2. A flange handle (STDA1X)
3. A variable depth operating mechanism

When using a circuit breaker with a Spectra Flex™ cable operator, order:

1. A circuit breaker
2. A flange-mounted handle mechanism
3. A breaker-mounted mechanism
4. An operating cable

Siemens ITE Max-Flex™

When using a disconnect switch, order:

1. A basic switch (right-hand)
2. A fuse or no-fuse kit
3. A flange-mounted handle (FHOHS4)
4. Switch operator
5. Cable, 36.00"

When using a circuit breaker, order:

1. A circuit breaker
2. Pressure wire connectors
3. A flange-mounted handle (FH0H4)
4. A circuit breaker operator mechanism
5. An operating cable (standard 36.00")

Schneider Square D®

When using a Class 9422 disconnect switch, order:

1. A disconnect switch with operating mechanism (Class 9422)
2. A handle mechanism (Class 9422 Type A-2 or A-1)

When using a circuit breaker, order:

1. A circuit breaker (Schneider Square D®)
2. An operating mechanism (Class 9422)
3. A handle mechanism (Class 9422 Type A-2 or A-1)

When using a Class 9422 Type "T" disconnect switch with a cable mechanism, order:

1. A disconnect switch with operating mechanism (Class 9422, Type T)
2. A handle mechanism (Class 9422 Type A-1)

3. A cable mechanism (Class 9422 CFT_O) 3-, 5-, or 10-foot

When using a circuit breaker with a cable mechanism, order:

1. A circuit breaker (Schneider Square D®)
2. A handle mechanism (Class 9422 Type A-1)
3. A cable mechanism (Class 9422 CFT_O) 3-, 5-, or 10-foot

** Items available from disconnect manufacturer as complete kits.*

**ABN12, SDN12, SDN12PL, N412CD,
N412CSTD, N412CSSSTD, SN4 & SSN4X SERIES ENCLOSURES
DISCONNECT SPACE OCCUPIED & AVAILABLE WIRING SPACE INFORMATION**

ALLEN-BRADLEY BULLETIN 1494V DISCONNECTS

Type Number	Amp Rating	Fuse Clip	Fuse Class	Wire Bend Space "WB" Above Disconnect						
				Space Occupied		ABN12, SDN12, SDN12PL, N412CD, N412CSTD & N412CSSSTD (pages G2-G9)			SN4 & SSN4X wall-mounts (pages G10-G13)	
				F	G*	When D= 8.00 WB	When D= 10.00 WB	When D= 12 or 16 WB	When D= 8.00 WB	When D= 12.00 WB
DS30	30A	No fuse	—	3.88	6.62	2.78	5.15	9.66	6.66	9.66
DS30	30A	30A-250V	H, K, R	5.25	6.62	2.78	5.15	9.66	6.66	9.66
DS30	30A	30A-600V	H, K, R	8	6.62	2.78	5.15	9.66	6.66	9.66
DS30	30A	30A-600V	J	5.25	6.62	2.78	5.15	9.66	6.66	9.66
DS30	30A	60A-250V	H, K	6	6.62	2.78	5.15	9.66	6.66	9.66
DS30	30A	60A-600V	H, K	8.5	6.62	2.78	5.15	9.66	6.66	9.66
DS30	30A	60A-600V	J	5.38	6.62	2.78	5.15	9.66	6.66	9.66
DS60	60A	No fuse	—	3.88	6.62	2.01	4.35	8.89	5.89	8.89
DS60	60A	60A-250V	H, K, R	6	6.62	2.01	4.35	8.89	5.89	8.89
DS60	60A	60A-600V	H, K, R	8.5	6.62	2.01	4.35	8.89	5.89	8.89
DS60	60A	60A-600V	J	5.38	6.62	2.01	4.35	8.89	5.89	8.89
DS60	60A	30A-600V	H, K, R	8	6.62	2.01	4.35	8.89	5.89	8.89
DS60	60A	100A-250V	H, K	8.5	6.62	2.01	4.35	8.89	5.89	8.89
DS60	60A	100A-600V	H, K	10.5	6.62	2.01	4.35	8.89	5.89	8.89
DS60	60A	100A-600V	J	7.25	6.62	2.01	4.35	8.89	5.89	8.89
DS100	100A***	No fuse	—	3.88	6.62	—	4.17	8.67	5.7	8.7
DS100	100A***	100A-250V	H, K, R	8.12	6.62	—	4.17	8.67	5.7	8.7
DS100	100A***	100A-600V	H, K, R	10.12	6.62	—	4.17	8.67	5.7	8.7
DS100	100A***	100A-600V	J	6.88	6.62	—	4.17	8.67	5.7	8.7
DS100	100A***	60A-600V	H, K, R	10.12	6.62	—	4.17	8.67	5.7	8.7
DS100	100A***	60A-600V	J	8.88	6.62	—	4.17	8.67	5.7	8.7
DS200	200A***	No fuse	—	4.75	7.88	—	—	8.12	—	8.12
DS200	200A***	200A-250V	H, K, R	10.88	7.88	—	—	8.12	—	8.12
DS200	200A***	200A-600V	H, K, R	13.38	7.88	—	—	8.12	—	8.12
DS200	200A***	200A-600V	J	9.5	7.88	—	—	8.12	—	8.12
DS200	200A***	100A-600V	H, K, R	12	7.88	—	—	8.12	—	8.12
DS200	200A***	100A-600V	J	8.75	7.88	—	—	8.12	—	8.12
DS400	400A**	No fuse	—	10.75	10.88	—	—	—	—	—
DS400	400A**	400A-250V	H, K, R	16.12	10.88	—	—	—	—	—
DS400	400A**	400A-600V	H, K, R	19.12	10.88	—	—	—	—	—
DS400	400A**	400A-600V	J	14.62	10.88	—	—	—	—	—
DS600	600A	No fuse	—	10.75	10.88	—	—	—	—	—
DS600	600A****	600A-250V	H, R	10.75	10.88	—	—	—	—	—
DS600	600A****	600A-600V	H, R	10.75	10.88	—	—	—	—	—
DS600	600A	600A-600V	J	17.59	10.88	—	—	—	—	—

ALLEN-BRADLEY BULLETIN 1494V DISCONNECTS

M40	15A-150A	EHD, FD, FDB FDC, HFD, HMCP,	—	5	4.5	4.25	6.62	11.12	8.12	11.12
M50	70A-250A	Circuit Breakers JD, JDB, JDC, HJD, HMCP	—	9.75	4.75	—	—	10.62	—	10.62
M60	100A-400A	Circuit Breakers KD, KDB, KDC, HKD, HMCP	—	9.69	6.12	—	—	10.5	—	10.5

* Does not include space for optional auxiliary switch.

** The 400 amp disconnect switch and the 600 amp disconnect switch will only fit catalog number SDN12603812A (see page G4). Wire bend space of 12.13" is provided above disconnect when installed.

*** Series B

**** "F" and "G" do not include separately mounted fuse blocks.

**ABN12, SDN12, SDN12PL, N412CD,
N412CSTD, N412CSSSTD, SN4 & SSN4X SERIES ENCLOSURES
DISCONNECT SPACE OCCUPIED & AVAILABLE WIRING SPACE INFORMATION**

G17

ABB CONTROLS DISCONNECT SWITCHES WITH FLANGE-MOUNTED OPERATORS

Type Number	Amp Rating	Fuse Clip	Fuse Class	Wire Bend Space "WB" Above Disconnect							
				Space Occupied			ABN12, SDN12, SDN12PL, N412CD, N412CSTD & N412CSSSTD (pages G2-G9)			SN4 & SSN4X wall-mounts (pages G10-G13)	
				F	G*	When D= 8.00 WB	When D= 10.00 WB	When D= 12 or 16 WB	When D= 8.00 WB	When D= 12.00 WB	
OETL-NF30-F	40A	No fuse	—	4.45	3.78	6.41	8.75	13.28	10.28	13.28	
OETL-NF60-F	80A	No fuse	—	4.86	3.78	6.22	8.56	13.09	10.09	13.09	
OETL-NF100-F	100A	No fuse	—	4.86	4.78	5.66	8	12.53	9.53	12.53	
OETL-NF175-F	175A	No fuse	—	7.3	6.49	—	5.75	10.28	7.28	10.28	
OETL-NF200-F	200A	No fuse	—	7.36	7.28	—	5.75	10.28	7.28	10.28	
OESA-F30J6-F	30A	30A-600V	J	4.28	6.58	4.73	7.07	11.61	8.61	11.61	
OESA-F60J6-F	60A	60A-600V	J	4.28	6.26	4.73	7.07	11.61	8.61	11.61	
OESA-F100J6-F	100A	100A-600V	J	6.54	7.65	4.3	6.64	11.17	8.17	11.17	

ABB CONTROLS CIRCUIT BREAKERS WITH FLANGE-MOUNTED OPERATORS

Mechanism	Amp Rating	Wire Bend Space "WB" Above Disconnect							
		Space Occupied			ABN12, SDN12, SDN12PL, N412CD, N412CSTD & N412CSSSTD (pages G2-G9)			SN4 & SSN4X wall-mounts (pages G10-G13)	
		F	G*	When D= 8.00 WB	When D= 10.00 WB	When D= 12 or 16 WB	When D= 8.00 WB	When D= 12.00 WB	
K2FHD-M	100A	6.92	3.94	3.39	5.73	10.26	7.26	10.26	
K3FHD-M	150A-225A	5.98	4.23	—	—	5.56	5.56	5.56	
K4FHD-M	250A	7.44	4.23	—	—	3.95	—	3.95	
K5FHD-M	400A	9.71	5.62	—	—	—	—	—	
K5FHD-M	600A/800A	8.28	11.26	—	—	—	—	—	
K5FHD-M	800A	10.11	11.26	—	—	—	—	—	

EATON CUTLER-HAMMER C361 CIRCUIT DISCONNECT SWITCHES

Switch Number	Type Number	Amp Rating	Fuse Clip	Fuse Class	Wire Bend Space "WB" Above Disconnect							
					Space Occupied			ABN12, SDN12, SDN12PL, N412CD, N412CSTD & N412CSSSTD (pages G2-G9)			SN4 & SSN4X wall-mounts (pages G10-G13)	
					F	G*	When D= 8.00 WB	When D= 10.00 WB	When D= 12 or 16 WB	When D= 8.00 WB	When D= 12.00 WB	
C361	NC	30A	No fuse	—	5.75	7.43	3.44	5.75	10.31	7.31	10.31	
C361	SC21	30A	30A-250V	H, K, R	8.38	7.43	3.44	5.75	10.31	7.31	10.31	
C361	SC61	30A	60A-250V	H, K, R	8.38	7.43	3.44	5.75	10.31	7.31	10.31	
C361	SC61	30A	30A-600V	H, J, K, R	8.38	7.43	3.44	5.75	10.31	7.31	10.31	
C361	ND	60A	No fuse	—	5.75	7.43	3.44	5.75	10.31	7.31	10.31	
C361	SD22	60A	60A-250V	H, K, R	8.38	7.43	3.44	5.75	10.31	7.31	10.31	
C361	SD22	60A	30A-600V	J	8.38	7.43	3.44	5.75	10.31	7.31	10.31	
C361	SD62	60A	60A-600V	H, K, R	8.38	7.43	3.44	5.75	10.31	7.31	10.31	
C361	SD62	60A	60A-600V	J	8.38	7.43	3.44	5.75	10.31	7.31	10.31	
C361	NE	100A	No fuse	—	5.56	8.95	3	5.38	9.91	7.47	9.91	
C361	SE263	100A	100A-250V	H, K, R	10.31	8.95	3	5.38	9.91	7.47	9.91	
C361	SE263	100A	100A-600V	H, K, R	10.31	8.95	3	5.38	9.91	7.47	9.91	
C361	SE263	100A	100A-600V	J	10.31	8.95	3	5.38	9.91	7.47	9.91	
C361	NF*	200A	No fuse	—	13.06	10	—	—	7.94	4.94	7.94	
C361	SF264*	200A	200A-250V	H, K, R	13.06	10	—	—	7.94	4.94	7.94	
C361	SF264*	200A	200A-600V	H, J, K, R	13.06	10	—	—	7.94	4.94	7.94	

*200 amp switch should be installed in an enclosure with an "H" dimension of 30.00" (762mm) or more.

ABN12, SDN12, SDN12PL, N412CD, N412CSTD, N412CSSSTD, SN4 & SSN4X SERIES ENCLOSURES DISCONNECT SPACE OCCUPIED & AVAILABLE WIRING SPACE INFORMATION

EATON CUTLER-HAMMER C371 CIRCUIT BREAKER OPERATORS FOR C-H CIRCUIT BREAKERS

Type Number	Max Amp Rating	Frame Type	Wire Bend Space "WB" Above Disconnect						
			Space Occupied		ABN12, SDN12, SDN12PL, N412CD, N412CSTD & N412CSSSTD (pages G2-G9)			SN4 & SSN4X wall-mounts (pages G10-G13)	
			F	G*	When D= 8.00 WB	When D= 10.00 WB	When D= 12 or 16 WB	When D= 8.00 WB	When D= 12.00 WB
C371E	225A	F Frame: EHD, FDB, FD, HFD, FDC	6	5.5	4.44	6.81	11.44	8.44	11.44
C371E	150A	F Frame: HMCP	6	5.5	4.44	6.81	11.44	8.44	11.44
C371F	250A	J Frame: JDB, JD, HJD, JDC	8.94	8	—	6.75	11.25	—	11.25
C371F	250A	J Frame: HMCP	10.94	8	—	6.75	11.25	—	11.25
C371F	400A	K Frame: dk, kdb, kd, hkd	9.75	8	—	—	10.75	—	10.75
C371F	400A	K Frame: HMCP	9.75	8	—	—	10.75	—	10.75
C371G	600A	L Frame: ld, hld, ldc	8.44	11.88	—	—	9.18	—	9.18
C371G	600A	L Frame: HMCP	8.44	11.88	—	—	9.18	—	9.18

EATON CUTLER-HAMMER FLEX SHAFT™ OPERATOR MECHANISM FOR C-H CIRCUIT BREAKERS

Complete Operator Mechanism	Amp Rating	Frame Type	Breaker Height	Breaker Width
F1S03	225A	F FRAME: EHD, FDB, FD, HFD, FDC	6	4.12
F1S03	150A	F FRAME: HMCP	6	4.12
F2S03	250A	J FRAME: JDB, JD, HJD, JDC	10	4.12
F2S03	250A	J FRAME: HMCP	10	4.12
F3S03	400A	K FRAME: DK, KDB, KD, HKD	10.12	5.5
F3S03	400A	K FRAME: HMCP	12.45	5.5
F4S04	600A	L FRAME: LD, HLD, LDC	10.75	8.25
F4S04	600A	L FRAME: HMCP	12.5	8.25
F7S04	800A	M FRAME: MD, MDS	16	8.25
F5S04	1200A	N FRAME: ND, HND, NDC	16	8.25
F6S04	2500A	R FRAME: RD, CRD, RDC	16	15.5

Catalog numbers for complete mechanisms include a flange-mounted handle, flexible shaft and circuit breaker mechanism. The last digit of the catalog number denotes the length of shaft (F1S03 = 3-foot shaft). The F, J, K frame Flex Shafts™ are available in 3-foot to 10-foot lengths. The L, N, R frame Flex Shafts are available in 4-foot to 6-foot lengths.

Space Occupied by Disconnect

- The Flex Shaft™ system allows the circuit breaker to be positioned independent from the flange-mounted handle mechanism.
- Refer to National Electrical Code® article 430-10(b) for wiring space "WB" required for line side conductors.
- Choose the length of shaft based on placement of the circuit breaker in the enclosure ensuring a 4-inch min. bending radius for the Flex Shaft™.
- Space occupied by circuit breaker is determined by overall height "X", width "Y", wire bend space "WB" and location "G" as selected from right to left.

**ABN12, SDN12, SDN12PL, N412CD,
N412CSTD, N412CSSSTD, SN4 & SSN4X SERIES ENCLOSURES
DISCONNECT SPACE OCCUPIED & AVAILABLE WIRING SPACE INFORMATION**

GENERAL ELECTRIC TYPE STDA OPERATORS FOR DISCONNECTS

Mechanism	Amp Rating	Fuse Clip	Fuse Class	Wire Bend Space "WB" Above Disconnect						
				Space Occupied		ABN12, SDN12, SDN12PL, N412CD, N412CSTD & N412CSSSTD (pages G2-G9)			SN4 & SSN4X wall-mounts (pages G10-G13)	
				F	G*	When D= 8.00 WB	When D= 10.00 WB	When D= 12 or 16 WB	When D= 8.00 WB	When D= 12.00 WB
TDOM1A	30A	No fuse	—	7.75**	5.25	6.18*	7.62	12.12	9.12	12.12
TDOM1A	30A	30A-250V	H, R	7.75**	5.25	6.18*	7.62	12.12	9.12	12.12
TDOM1B	30A	30A-600V	H, R	12.38**	5.25	6.18*	7.62	12.12	9.12	12.12
TDOM1B	30A	60A-250V	H, R	12.38**	5.25	6.18*	7.62	12.12	9.12	12.12
TDOM1B	30A	60A-600V	H, R	12.38**	5.25	6.18*	7.62	12.12	9.12	12.12
TDOM1A	60A	No fuse	—	7.75**	5.25	6.18*	7.62	12.12	9.12	12.12
TDOM1B	60A	60A-250V	H, R	12.38**	5.25	6.18*	7.62	12.12	9.12	12.12
TDOM1B	60A	60A-600V	H, R	12.38**	5.25	6.18*	7.62	12.12	9.12	12.12
TDOM1B	60A	100A-250V	H, R	12.38**	5.25	6.18*	7.62	12.12	9.12	12.12
TDOM1B	60A	100A-600V	H, R	12.38**	5.25	6.18*	7.62	12.12	9.12	12.12
TDOM1A	100A	No fuse	—	7.75**	5.25	6.18*	7.62	12.12	9.12	12.12
TDOM1B	100A	100A-250V	H, R	12.38**	5.25	6.18*	7.62	12.12	9.12	12.12
TDOM1B	100A	100A-600V	H, R	12.38**	5.25	6.18*	7.62	12.12	9.12	12.12
TDOM1B	100A	200A-250V	H, R	12.38**	5.25	6.18*	7.62	12.12	9.12	12.12
TDOM1B	100A	200A-600V	H, R	12.38**	5.25	6.18*	7.62	12.12	9.12	12.12
TDOM2	200A	No fuse	—	7	9.12	—	—	9.5	6.5	9.5
TDOM2	200A	200A-250V	H, R	15.38	9.12	—	—	9.5	6.5	9.5
TDOM2	200A	200A-600V	H, R	15.38	9.12	—	—	9.5	6.5	9.5

* Disconnect moved down .88" to fit on panel.

**Dimension applies to 8.00" (203mm) deep enclosures and is .88" less in deeper enclosures.

GENERAL ELECTRIC TYPE STDA OPERATORS FOR DISCONNECTS

Mechanism	Amp Rating	Frame Type	Wire Bend Space "WB" Above Disconnect						
			Space Occupied		ABN12, SDN12, SDN12PL, N412CD, N412CSTD & N412CSSSTD (pages G2-G9)			SN4 & SSN4X wall-mounts (pages G10-G13)	
			F	G*	When D= 8.00 WB	When D= 10.00 WB	When D= 12 or 16 WB	When D= 8.00 WB	When D= 12.00 WB
SDOM1A	150A	TEB, TED, THED	7.75**	5.25	6.06*	7.5	12.06	9.06	12.06
SDOM1A	150A	TEC	7.75**	5.25	6.06*	7.5	12.06	9.06	12.06
TDOM1B	150A	TB1	12.38**	5.25	6.06*	7.5	12.06	9.06	12.06
TDOM1B	150A	TEC, TECL	12.38**	5.25	6.06*	7.5	12.06	9.06	12.06
TDOM1C	150A	TEL	7.75**	5.25	6.06*	7.5	12.06	9.06	12.06
TDOM1D	150A	THLC1	7.75**	5.25	—	5.12	9.62	6.62	9.62
TDOM3	225A	TFJ	10.38	5.75	—	6.06	10.62	7.62	10.62
TDOM3	225A	TFK, THFK, TFL	10.38	5.75	—	6.06	10.62	7.62	10.62
TDOM4	400A	TJJ, TJK4, THJK4, TJL4V	8.25	9.38	—	5.12	9.69	6.69	9.69
TDOM4	600A	TJK6, THJK6, TJ4V, TJL4V	8.25	9.38	—	5.12	9.69	6.69	9.69
TDOM5	400A	TB4, TJH6S	14.25	9.38	—	5.12	9.69	6.69	9.69
TDOM6	225A	TLB2, THLC2	11.75	9.38	—	—	9.12	6.12	9.12
TDOM6	400A	TLB4, THLC4	11.75	9.38	—	—	7.75	4.75	7.75
SDOM1A	150A	SPECTRA SE150	7.75**	5.25	6.06*	7.5	12.06	9.06	12.06
SDOM3	250A	SPECTR SF250	10.38	5.75	—	6.06	10.62	7.06	10.06
SDOM4	600A	SPECTRA SG600	10	7	—	—	7.93	—	7.93

* Disconnect moved down .88" to fit on panel.

**Dimension applies to 8.00" (203mm) deep enclosures and is .88" less in deeper enclosures.

ABN12, SDN12, SDN12PL, N412CD, N412CSTD, N412CSSSTD, SN4 & SSN4X SERIES ENCLOSURES DISCONNECT SPACE OCCUPIED & AVAILABLE WIRING SPACE INFORMATION

GENERAL ELECTRIC CIRCUIT BREAKERS WITH SPECTRA FLEX™ CABLE OPERATORS

Frame Size	Maximum Amp Rating	Circuit Breaker Height X	Circuit Breaker Width Y	ABN12, SDN12, SDN12PL, N412CD, N412CSTD & N412CSSSTD (pages G2-G9)	SN4 & SSN4X wall-mounts (pages G10-G13)
E150	150A	6.31	4.12	For enclosures that accept these devices, see pages G2-G9.	For enclosures that accept these devices, see pages G10-G13
SE150	150A	6.31	4.12		
SF250	250A	10.12	4.12		
SG600	600A	10.09	5.5		
SK1200	1200A	15.5	8.25		

Frame Size	Breaker Mechanism	Flange Mounting Handle	Operating Cable
E150	SCOM1A	SCH1	SC3L
SE150/SF250	SCOM1EF	SCH1	SC3L
SG600	SCOM1G	SCH1	SC3L
SK1200	SCOM1K	SCH2K	SC3H

* Operating cables are available in 3-foot to 10-foot lengths. (The number 3 in the catalog number denotes 3-foot cable.)

** Add "X" for NEMA 4 or 4X flange-mounted handle.

Space Occupied by Circuit Breaker

- The General Electric Spectra-Flex™ system allows the circuit breaker to be positioned independent from the flange-mounted handle mechanism.
- Refer to **National Electrical Code®** article 430-10(b) for wiring space "WB" required for line side conductors.
- Choose the operating cable length based on placement of the circuit breaker in the enclosure ensuring a 3" minimum bending radius for the cable.
- Space occupied by circuit breaker is determined by overall circuit breaker size ("X" height and "Y" width) plus "WB" wire bend space and location "G" as selected from right to left.

I-T-E DISCONNECT SWITCHES FOR MAX-FLEX™ OPERATORS

Switch	Amp Rating	Fuse Clip	Fuse Class	Disconnect Height X	Disconnect Width Y	ABN12, SDN12, SDN12PL, N412CD, N412CSTD & N412CSSSTD (pages G2-G9)	SN4 & SSN4X wall-mounts (pages G10-G13)
MCS603R	30A	No fuse	—	5.52	6.13	For enclosures that accept these devices, see pages G2-G9.	For enclosures that accept these devices, see pages G10-G13
MCS603R	30A	30A-250V	H, K, R	8.11	6.13		
MCS603R	30A	30A-600V	H, K, R	10.11	6.13		
MCS603R	30A	30A-600V	J	8.48	6.13		
MCS606R	60A	No fuse	—	5.52	6.13		
MCS606R	60A	60A-250V	H, K, R	7.86	6.13		
MCS606R	60A	60A-600V	H, K, R	10.38	6.13		
MCS606R	60A	60A-600V	J	8.36	6.13		
MCS610R	100A	No fuse	—	7.59	7.38		
MCS610R	100A	100A-250V	H, K, R	11.85	7.38		
MCS610R	100A	100A-600V	H, K, R	13.85	7.38		
MCS610R	100A	100A-600V	J	10.6	7.38		
MCS620R	200A	No fuse	—	9.02	9.17		
MCS620R	200A	200A-250V	H, K, R	14.7	9.17		
MCS620R	200A	200A-600V	H, K, R	17.2	9.17		
MCS620R	200A	200A-600V	J	13.32	9.17		

ABN12, SDN12, SDN12PL, N412CD, N412CSTD, N412CSSSTD, SN4 & SSN4X SERIES ENCLOSURES DISCONNECT SPACE OCCUPIED & AVAILABLE WIRING SPACE INFORMATION

SIEMENS ITE CIRCUIT BREAKERS FOR MAX-FLEX™ OPERATORS

Complete Operator Mechanism	Circuit Breaker Frame	Maximum Amp Rating	Circuit Breaker Height X	Circuit Breaker Width Y	Circuit Breaker Type
FHOE036	ED	125A	6.34	3	ED2, ED4, ED6, HED4, HED6
FHOE036	CED	125A	9.58	3	CED6
FHOF036	FD	250A	9.5	4.5	FXD6-A, FD6-A, HFD6, FXD6-ETJ, HHFD6, HHFXD6
FHOJ036	CFD	250A	14.25	4.5	CFD6, CFD6-ETI
FHOJ036	JD	400A	11	7.5	JXD2, JXD6, JD6, HJD6, HHJD6, HHJXD6, JXD6-ETI
FHOJ036	CJD	400A	17.86	7.5	CJD6, CJD6-ETI
FHOJ036	LD	600A	11	7.5	LXD6, LD6, HLD6, HHLXD6, HHLXD6-ETI
FHOJ036	CLD	600A	17.86	7.5	CLD6, CLD6-ETI
FHOLM036	LMD	800A	16	9	LMD6, LMXD6, HLMXD6, HLMXD6-ETI
FHON048*	MD	800A	24	9	MD2, MXD6, HMD6, HMXD6, CMD6, MXD6-ETI, CMD6-ETI
FHON048*	ND	1200A	24	9	ND6, NXD6, HND6, HNXD6, CND6

Mechanisms and circuit breakers listed above will fit any disconnect wall-mounts on pages G10-G13, or SN4 wall-mounts on pages G2-G9 except as noted.

The last 3 digits of operator mechanism number indicates cable length in inches. Also 48" cables are available for ED, FD, JD/LD operators, and 60" cables for MD/ND, PD/RD operators.

For Type 4 applications order handle, cable and circuit breaker separately.

*This operator mechanism can only be installed in catalog number SDN12603812A (see page G4) which has the appropriate flange cutout.

Space Occupied by Disconnect

- The Siemens ITE Max-Flex™ cable system allows the disconnect to be positioned independent from the flange-mounted handle mechanism.
- Refer to **National Electrical Code®** article 430-10(b) for wiring space "WB" required for line side conductors.
- Refer to Siemens ITE Max-Flex™ installation instructions for limits on disconnect location when 36-inch or 48-inch Max-Flex™ cables.
- Space occupied by disconnect is determined by overall height "X", width "Y", wire bend space "WB" and location "G" as selected from right to left.

SCHNEIDER SQUARE D® CLASS 9422 DISCONNECT SWITCHES USED WITH CABLE MECHANISM 9422-CFT30 & 9422A-1 HANDLE MECHANISM

Switch	Amp Rating	Fuse Clip	Fuse Class	Disconnect Height X	Disconnect Width Y	ABN12, SDN12, SDN12PL, N412CD, N412CSTD & N412CSSSTD (pages G2-G9)	SN4 & SSN4X wall-mounts (pages G10-G13)
TCN-30C	30A	No fuse	—	5.9	6.2		
TCF-30C	30A	30A-250V	H, K, R	7.5	6.2		
TCF-33C	30A	30A-600V	H, K, R	10.15	6.2		
TCF-33C	30A	60A-250V	H, K, R	8.15	6.2		
TCF-33C	30A	30A-600V	J	7.5	6.2		
TDN-60C	60A	No fuse	—	5.9	6.2		
TDF-60C	60A	30A-600V	H, K, R	10.15	6.2	For enclosures that accept these devices, see pages G2-G9.	For enclosures that accept these devices, see pages G10-G13
TDF-60C	60A	60A-250V	H, K, R	8.15	6.2		
TDF-63C	60A	60A-600V	H, K, R	10.65	6.2		
TDF-63C	60A	60A-600V	J	7.5	6.2		
TEN-10C	100A	No fuse	—	5.9	6.2		
TEF-10C	100A	100A-250V	H, K, R	10.35	6.2		
TEF-10C	100A	100A-600V	H, K, R	10.35	6.2		
TEF-10C	100A	100A-600V	J	10.35	6.2		

Use switches listed above with appropriate cable mechanism and 9422-A1 handle mechanism.

SCHNEIDER SQUARE D® CLASS 9422 CABLE MECHANISM FOR CIRCUIT BREAKERS

Cable Type Switch	Amp Rating	Frame Type	Disconnect Height X	Disconnect Width Y	ABN12, SDN12, SDN12PL, N412CD, N412CSTD & N412CSSSTD (pages G2-G9)	SN4 & SSN4X wall-mounts (pages G10-G13)
9422 CGJ30	75A	GJL	4.75	3.5		
9422 CGJ300	100A	GJL	4.75	3.5		
9422 CGJ30	100A	FAL, FHL	6	4.5	For enclosures that accept these devices, see pages G2-G9.	For enclosures that accept these devices, see pages G10-G13
9422 CGJ30	250A	KAL, KHL	8	4.5		
9422 CGJ30	400A	LAL, LHL, Q4L	11	6		

Space Occupied by Disconnect Switch or Circuit Breaker

- Schneider Square D® cable mechanisms allows disconnect devices to be positioned independent from the flange-mounted handle mechanism.
- Refer to **National Electrical Code®** article 430-10(b) for wiring space "WB" required for line side conductors.

- Choose cable mechanism length based on placement of disconnect in enclosure. See Schneider Square D® Instruction Bulletin for minimum bend radius for cable.
- Space occupied by disconnect is determined by overall height "X", width "Y", wire bend space "WB" and location "G" as selected from right to left.

**ABN12, SDN12, SDN12PL, N412CD,
N412CSTD, N412CSSSTD, SN4 & SSN4X SERIES ENCLOSURES
DISCONNECT SPACE OCCUPIED & AVAILABLE WIRING SPACE INFORMATION**
SCHNEIDER SQUARE D® CLASS 9422 VARIABLE DEPTH DISCONNECT

Mechanism	Amp Rating	Fuse Clip	Fuse Class	Space Occupied		Wire Bend Space "WB" Above Disconnect				
						ABN12, SDN12, SDN12PL, N412CD, N412CSTD & N412CSSSTD (pages G2-G9)			SN4 & SSN4X wall-mounts (pages G10-G13)	
						When D= 8.00 WB	When D= 10.00 WB	When D= 12 or 16 WB	When D= 8.00 WB	When D= 12.00 WB
TCN-30	30A	No fuse	—	3.8	6.84	3.69	6.03	10.56	7.56	10.56
TCF-30	30A	30A-250V	H, K, R	5.53	6.84	3.69	6.03	10.56	7.56	10.56
TCF-33	30A	30A-600V	H, K, R	8.15	6.84	3.69	6.03	10.56	7.56	10.56
TCF-33	30A	60A-250V	H, K, R	6.15	6.84	3.69	6.03	10.56	7.56	10.56
TCF-33	30A	30A-600V	J	5.53	6.84	3.69	6.03	10.56	7.56	10.56
TDN-60	60A	No fuse	—	3.8	6.84	3.69	6.03	10.56	7.56	10.56
TDF-60	60A	30A-600V	H, K, R	8.15	6.84	3.69	6.03	10.56	7.56	10.56
TDF-60	60A	60A-250V	H, K, R	6.15	6.84	3.69	6.03	10.56	7.56	10.56
TDF-63	60A	60A-600V	H, K, R	8.65	6.84	3.69	6.03	10.56	7.56	10.56
TDF-63	60A	60A-600V	J	5.53	6.84	3.69	6.03	10.56	7.56	10.56
TEN-10	100A	No fuse	—	3.8	6.84	—	5.91	10.44	7.44	10.44
TEF-10	100A	100A-250V	H, K, R	8.25	6.84	—	5.91	10.44	7.44	10.44
TEF-10	100A	100A-600V	H, K, R	10.25	6.84	—	5.91	10.44	7.44	10.44
TEF-10	100A	100A-600V	J	7.05	6.84	—	5.91	10.44	7.44	10.44
TC-1	30A	No fuse	—	5.75	6	3.12	5.12	9.62	6.62	9.62
TC-2	30A	30A-250V	H, K, R	5.75	6	3.12	5.12	9.62	6.62	9.62
TC-3	30A	30A-600V	H, K, R	7.75	6	3.12	5.12	9.62	6.62	9.62
TC-3	30A	60A-250V	H, K, R	5.88	6	3.12	5.12	9.62	6.62	9.62
TC-3	30A	30A-600V	J	5.75	6	3.12	5.12	9.62	6.62	9.62
TD-1	60A	No fuse	—	6.38	6.62	3.62	6	10.5	7.5	10.5
TD-2	60A	30A-600V	H, K, R	8.5	6.62	3.62	6	10.5	7.5	10.5
TD-2	60A	60A-250V	H, K, R	6.5	6.62	3.62	6	10.5	7.5	10.5
TD-3	60A	60A-600V	H, K, R	9	6.62	3.62	6	10.5	7.5	10.5
TD-3	60A	60A-600V	J	6.38	6.62	3.62	6	10.5	7.5	10.5
TE-1	100A	No fuse	—	4.75	8.38	—	5.75	10.25	—	10.25
TE-2	100A	100A-250V	H, K, R	7.5	8.38	—	5.75	10.25	—	10.25
TE-2	100A	100A-600V	H, K, R	9.5	8.38	—	5.75	10.25	—	10.25
TE-2	100A	100A-600V	J	6.25	8.38	—	5.75	10.25	—	10.25
TE-3	100A	200A-600V	J	13.75	8.38	—	5.75	10.25	—	10.25
TF-1	200A	No fuse	—	5.5	11.62	—	—	8.88	—	8.88
TF-2	200A	200A-250V	H, K, R	11.5	11.62	—	—	8.88	—	8.88
TF-2	200A	200A-600V	H, K, R	14	11.62	—	—	8.88	—	8.88
TF-2	200A	200A-600V	J	10.12	11.62	—	—	8.88	—	8.88
TF-3	200A	400A-600V	J	14.5	11.62	—	—	8.88	—	8.88
SCHNEIDER SQUARE D® CLASS 9422 VARIABLE DEPTH										
RG-1	75A	GJL	Circuit breaker	3.53	3.74	3.59	5.93	10.47	7.47	10.47
RG-1	100A	GJL	Circuit breaker	3.53	3.74	3.59	5.93	10.47	7.47	10.47
RN-1	100A	FAL, FHL	Circuit breaker	5.12	5.25	3.75	6.12	10.62	7.62	10.62
RP-1	250A	KAL, KHL	Circuit breaker	7.12	5.62	4.25*	6.88	11.38	8.38	11.38
RR-1	400A	LAL,LHL,Q4L	Circuit breaker	7.62	8.75	—	—	7	—	7

*Not recommended except with #1 or smaller line conductors.



ABN12242108

Industry Standards

UL 508A, Type 12 & 13
CSA Certified, Type 12
NEMA/EEMAC Type 12 & 13

 UL File E64791

 CSA File LL66078

FEATURES-SPECIFICATIONS

Applications

Designed to house Allen-Bradley 1494F flange-mounted disconnect switches and 1494D flange-mounted operators for circuit breakers. Provides protection from dust, dirt, oil and water.

Construction

- Bodies and doors are fabricated from carbon steel
- Seams are continuously welded and ground smooth
- Rolled lip around all sides of the enclosure opening to exclude liquids and contaminants
- Doors are easily removed by pulling continuous hinge pin
- Doors are sealed with a poured in place gasket
- External mounting feet are provided
- Collar studs for mounting **optional** back panels are provided
- Grounding provisions are provided

- Holes are provided in body and door for mounting disconnect switch, operating mechanism and door hardware.
- Interlock Door latch is provided
- Locking bars are also provided for door hardware
- Spacers and screws are provided to secure disconnect switch and fuse block adapter plate to the panel
- Enclosures under 40" high require 2-point door hardware
- Enclosures 40" high and larger require 3-point door hardware
- Instructions to locate and install disconnect switches, circuit breakers, and operating mechanisms is provided

Finish

- ANSI 61 gray polyester powder inside and out
- **Optional** back panels are painted with a white polyester powder

- **Optional** "G" panels are pre-galvanized steel

Accessories

- Back panels (reference table)
- Blank Adapter Plates on page G60

IMPORTANT

- Disconnect switch or circuit breakers, operating handle, operating mechanism, and door hardware are not furnished with enclosure and must be ordered separately from the disconnect manufacturer
- Operator adapter plates are not required with this enclosure
- Disconnect and door hardware ordering information is located on page G25
- Review space occupied by disconnect drawing on page G25 and disconnect tables on page G26 to determine if the disconnect device you are using will fit the enclosure size you have selected

ABN12 FIXED DEPTH SERIES WALL-MOUNT DISCONNECT

Catalog Number	Enclosure Size HxWxD	Back Panel Catalog Number*		Back Panel Size AxB
		White	"G"	
ABN12242108	24.00x21.38x8.13 (610x543x206)	NP2420	NP2420	21.00x17.00 (533x432)
ABN12242508	24.00x25.38x8.13 (610x645x206)	NP2424	NP2424	21.00x21.00 (533x533)
ABN12302108	30.00x21.38x8.13 (762x543x206)	NP3020	NP3020	27.00x17.00 (686x432)
ABN12302508	30.00x25.38x8.13 (762x645x206)	NP3024	NP3024	27.00x21.00 (686x533)
ABN12362508	36.00x25.38x8.13 (914x645x206)	NP3624	NP3624	33.00x21.00 (838x533)
ABN12363108	36.00x31.38x8.13 (914x797x206)	NP3630	NP3630	33.00x27.00 (838x686)
ABN12423108	42.00x31.38x8.13 (1067x797x206)	NP4230	NP4230	39.00x27.00 (991x686)
ABN12242110	24.00x21.38x10.13 (610x543x257)	NP2420	NP2420	21.00x17.00 (533x432)
ABN12242510	24.00x25.38x10.13 (610x645x257)	NP2424	NP2424	33.00x21.00 (838x533)
ABN12302110	30.00x21.38x10.13 (762x543x257)	NP3020	NP3020	27.00x17.00 (686x432)

*Back panels must be ordered separately.

continued on page G24

ABN12 FIXED DEPTH SERIES ENCLOSURES NEMA 12 FLANGED SINGLE DOOR DISCONNECT

ABN12 FIXED DEPTH SERIES WALL-MOUNT DISCONNECT (CONT.)

Catalog Number	Enclosure Size HxWxD	Back Panel Catalog Number*		Back Panel Size AxB
		White	"G"	
ABN12362510	36.00x25.38x10.13 (914x645x257)	NP3624	NP3624G	33.00x21.00 (838x533)
ABN12363110	36.00x31.38x10.13 (914x797x257)	NP3630	NP3630G	33.00x27.00 (838x686)
ABN12423110	42.00x31.38x10.13 (1067x797x257)	NP4230	NP4230G	39.00x27.00 (991x686)
ABN12483710	48.00x37.38x10.13 (1219x949x257)	NP4836	NP4836G	45.00x33.00 (1143x838)
ABN12603710	60.00x37.38x10.13 (1524x949x257)	NP6036	NP6036G	57.00x33.00 (1448x838)
ABN12363212	36.00x32.38x12.13 (914x822x308)	NP3630	NP3630G	33.00x30.00 (838x762)
ABN12423212	42.00x32.38x12.13 (1067x822x308)	NP4230	NP4230G	45.00x30.00 (1143x762)
ABN12483812	48.00x38.38x12.13 (1219x975x308)	NP4836	NP4836G	45.00x34.00 (1143x864)
ABN12483812A***	48.00x38.38x12.13 (1219x975x308)	NP4836	NP4836G	45.00x34.00 (1143x864)
ABN12603812	60.00x38.38x12.13 (1524x975x308)	NP6036	NP6036G	57.00x34.00 (1448x864)
ABN12603812A***	60.00x38.38x12.13 (1524x975x308)	NP6036	NP6036G	57.00x34.00 (1448x864)
ABN12483816	48.00x38.38x16.13 (1219x975x410)	NP4836	NP4836G	45.00x33.00 (1143x838)
ABN12603816	60.00x38.38x16.13 (1524x975x410)	NP6036	NP6036G	57.00x33.00 (1448x838)

*Back panels must be ordered separately.

***Suitable for 200 AMP disconnect Switches and 1494F-L4 door hardware only. Blank adapter plate WA22BAP will not fit on these enclosures.

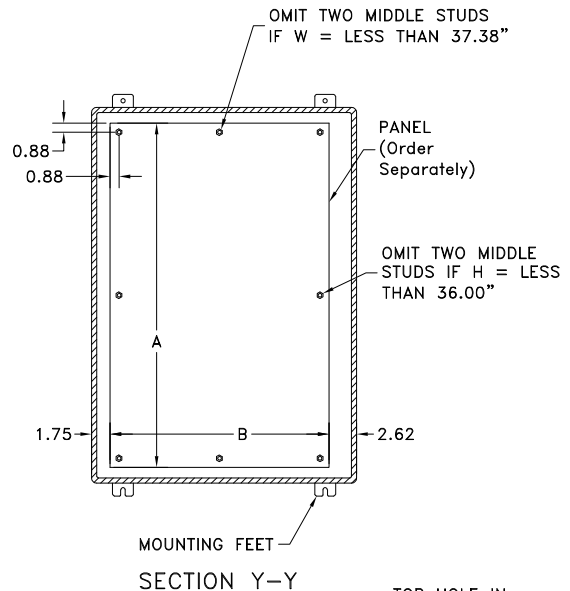
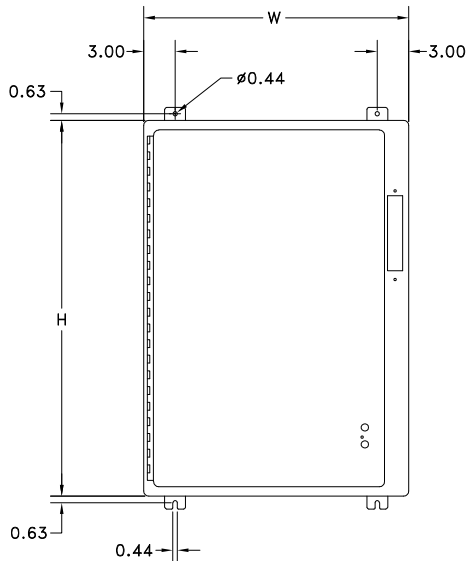

Note:

E = 3.84 when D = 8.00
 E = 6.75 when D = 10.00
 E = 9.50 when D = 12.00
 (Except enclosures for 200 amp switches)

E = 9.50 when D = 16.00
 E = 10.50 when D = 12.00
 (Except enclosures for 200 amp switches)
 WB = Wiring Space

Disconnects will occupy space on panel shown by Dimensions "E", "F", & "G". Wiring space "WB" is available when disconnect is installed in the enclosure.

Refer to National Electrical Code 1996 article 430-10(b) for wiring space required for line side conductors to be connected to disconnect. Verify your application to determine if wiring space is adequate.

THIS SPACE IS OCCUPIED BY DISCONNECT SWITCH AND FUSE CLIP (IF USED) OR CIRCUIT BREAKER.

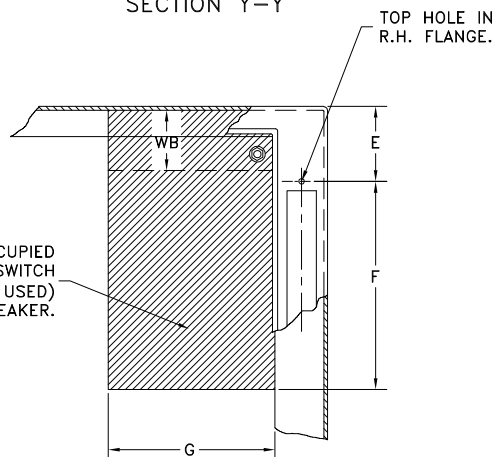

Space Occupied by Disconnect

- E = 3.84 when Depth = 8.00
- E = 6.75 when Depth = 10.00
- E = 9.50 when Depth = 12.00
(Except enclosures for 200 amp switches)
- E = 9.50 when Depth = 16.00
- E = 10.50 when Depth = 12.00
(Except enclosures for 200 amp switches)
- WB = Wiring Space

See page G26 for various brands of disconnects for "F", "G" & "WB" dimensions.

Disconnects will occupy space on panel shown by dimensions "E", "F" & "G". Wiring space "WB" is available when disconnect is installed in the enclosure.

Refer to *National Electrical Code*® article 430-10(b) for wiring space required for line side conductors to be connected to disconnect. Verify your application to determine if wiring space is adequate.

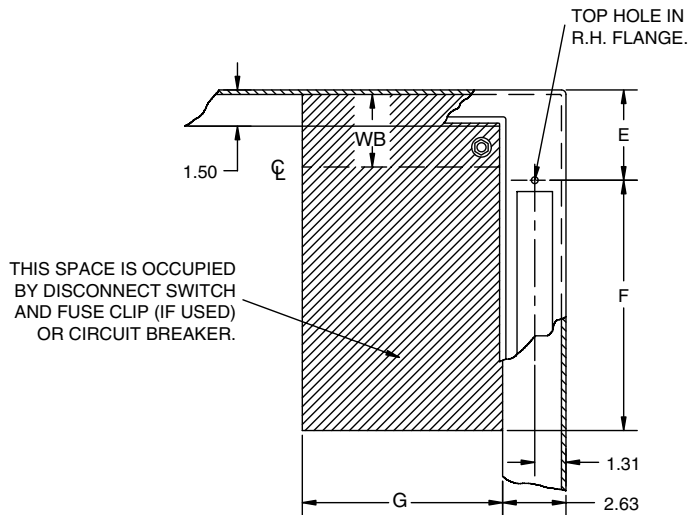

DISCONNECT ORDERING INFORMATION

When ordering wall-mounted disconnects from the following manufacturer, be sure to order all of the necessary items. Order the following items from the disconnect manufacturer.

Allen-Bradley

When using a Bulletin 1494F disconnect switch, order:

- * 1. A disconnect switch (30A, 60A, or 100A)
- 2. A fuse block adapter, if required
- 2. Line and load connectors, if required
- ** 4. Door hardware (Bulletin 1494F-L1 for 2-point latching, or Bulletin 1494F-L2 and 1494F-L3 for 3-point latching)

When using a Bulletin 1494D circuit breaker operating mechanism, order:

- 1. A circuit breaker (C-H)
- 2. An operating mechanism
- 3. A slide mechanism
- ** 4. Door hardware Bulletin 1494F-L1 for 2-point latching, or Bulletin 1494F-L2 and 1494F-L3 for 3-point latching)

PLEASE NOTE:

- 1. Operator adapter plates are not required with enclosures on page G60.
- 2. Various other switch accessories and circuit breaker accessories are available from disconnect manufacturers. The above information is subject to change without notice. Please contact Hubbell/Wiegmann or the disconnect manufacturer if there are further questions.
- 3. The "Space Occupied" tables (page G26) are based upon information supplied by the disconnect manufacturer. Hubbell/Wiegmann does not assume responsibility for the accuracy of these dimensions.

* Items available from disconnect manufacturer as complete kits.

**Enclosure "H" dimension less than 40" (1016mm) requires a 2-point door hardware (one Allen-Bradley catalog number 1494F-L1). Enclosures with an "H" dimension of 40.00-inches or more require a 3-point door hardware (one Allen-Bradley catalog number 1494F-L2 and one catalog number 1494F-L3).

**ABN12/1494F & 1494D SERIES ENCLOSURES
DISCONNECT SPACE OCCUPIED & AVAILABLE WIRING SPACE INFORMATION**

ALLEN-BRADLEY 1494F DISCONNECT SWITCHES

Fits Enclosure Depth				Type Number	Amp Rating	Fuse Clip	Fuse Class	Space Occupied		Wire Bend Space "WB" Above Disconnect ABN12, SDN12, SDN12PL, N412CD, N412CSTD & N412CSSSTD (pages G2-G9)		
8.00 (203)	10.00 (254)	12.00 (305)	16.00 (406)					F	G**	When E= 3.84 WB	When E= .75 WB	When E= 9.50 WB
•	•	•	•	N30	30A	No fuse	—	4.62	6.25	3.25	6.25	8.88
•	•	•	•	NF30	30A	30A-250V	H, K, R	6.25	6.25	3.25	6.25	8.88
•	•	•	•	NF30	30A	60A-250V	H, K, R	7.25	6.25	3.25	6.25	8.88
•	•	•	•	NF30	30A	30A-600V	H, K, R	9.25	6.25	3.25	6.25	8.88
•	•	•	•	NF30	30A	60A-600V	H, K, R	9.75	6.25	3.25	6.25	8.88
•	•	•	•	NF30	30A	30A-600V	J	6.5	6.25	3.25	6.25	8.88
•	•	•	•	NF30	30A	60A-600V	J	6.62	6.25	3.25	6.25	8.88
•	•	•	•	N60	60A	No fuse	—	4.62	6.25	2.5	5.25	8.12
•	•	•	•	NF60	60A	30A-600V	H, K, R	10.38	6.25	2.5	5.25	8.12
•	•	•	•	NF60	60A	60A-250V	H, K, R	8.38	6.25	2.5	5.25	8.12
•	•	•	•	NF60	60A	100A-250V	H, K, R	10.88	6.25	2.5	5.25	8.12
•	•	•	•	NF60	60A	60A-600V	H, K, R	10.88	6.25	2.5	5.25	8.12
•	•	•	•	NF60	60A	100A-600V	H, K, R	12.88	6.38	2.5	5.25	8.12
•	•	•	•	NF60	60A	60A-600V	J	7.75	6.25	2.5	5.25	8.12
•	•	•	•	NF60	60A	100A-600V	J	9.75	6.25	2.5	5.25	8.12
—	•	•	•	N100	100A	No fuse	—	4.62	7	—	3.5	6.25
—	•	•	•	NF100	100A	100A-250V	H, K, R	11.38	7	—	3.5	6.25
—	•	•	•	NF100	100A	200A-250V	H, K, R	12.25	7.25	—	3.5	6.25
—	•	•	•	NF100	100A	100A-600V	H, K, R	13.38	7.12	—	3.5	6.25
—	•	•	•	NF100	100A	200A-600V	H, K, R	14.75	7.38	—	3.5	6.25
—	•	•	•	NF100	100A	100A-600V	J	10.12	7	—	3.5	6.25
—	•	•	•	NF100	100A	200A-600V	J	10.88	7.25	—	3.5	6.25
—	—	•	—	N200	200A*	No fuse	—	7.12	10	—	—	7
—	—	•	—	NF200	200A*	200A-250V	H, K, R	15	10	—	—	7
—	—	•	—	NF200	200A*	400A-250V	H, K, R	16.56	10.38	—	—	7
—	—	•	—	NF200	200A*	200A-600V	H, K, R	17.56	10	—	—	7
—	—	•	—	NF200	200A*	400A-600V	H, K, R	19.56	10.62	—	—	7
—	—	•	—	NF200	200A*	200A-600V	J	13.69	10	—	—	7
—	—	•	—	NF200	200A*	400A-600V	J	15	10.25	—	—	7

ALLEN-BRADLEY 1494D CIRCUIT BREAKER OPERATORS

Fits Enclosure Depth				Type Number	Frame Rating	Breaker Type Frame Size (3 Pole)	Space Occupied		Wire Bend Space "WB" Above Disconnect ABN12/1494D (pages G23-25)		
8.00 (203)	10.00 (254)	12.00 (305)	16.00 (406)				F	G**	When E= 3.84 WB	When E= .75 WB	When E= 9.50 WB
•	•	•	•	N4/N40	150A	EHD, FD, FDB, FDC, HFD, HMCP	5.81	4.31	3.25	6.12	8.88
—	•	•	•	N5/N55	225A	General Electric TFK, THFK, TFC	8.81	4.5	—	5.34	8.09
—	•	•	•	N5/N50	250A	C-H JD, JDB, JDC, HJD, HMCP	8.81	4.5	—	5.31	8.06
—	•	•	•	N5/N60	400A	C-H KD, KDB, KDC, HKD, HMCP	8.81	5.62	—	5.44	8.19

* 200 amp switches can be installed only in 12.00-inch (305mm) deep enclosures that have provisions for 200 amp switches.

** The "G" dimension does not include space for auxiliary switches. See Allen-Bradley instructions for additional space required.



WA60X4912U



WA60CPX4912U

Industry Standards

UL 508A, Type 12
CSA Certified, Type 12
NEMA/EEMAC Type 12

 UL File E64791

 CSA File LL66078

FEATURES-SPECIFICATIONS

Construction

The Wiegmann universal cutout is used in large freestand and floorstand enclosures. Operator Adapter Kits are required in order to install the various manufacturers' hardware. Note that 400 A (or greater) disconnect switches and 600 A (or greater) circuit breakers need to use the "Large" or "High Amp" cutout, which is provided in the WA21ABVA kit for Allen-Bradley variable-depth disconnect switches or the WA21ITE kit for Siemens (and select other manufacturers) flex-cable devices. The "Large" or "High Amp" cutout accepts the larger operating handle whose mounting hole centers are 6.500-in. apart.

Allen-Bradley

- 1494V disconnect switches with flange-mount variable depth operating mechanisms and 1494V flange-mounted variable depth operating mechanisms for circuit breakers
- 140U flexible cable operating mechanisms and 140U molded case circuit breakers
- 1494C cable-operated disconnect switches with flange-mount handles
- 194RC cable-operated flange-mount handles for use with the NFPA 79 compliant 194R IEC rotary disconnect switches

Allen-Bradley 1494V-R1, -R2 and -W2 operating handles and Allen-Bradley 1494F disconnect devices or 1494D circuit breaker operators will NOT fit these enclosures.

- **ABB Controls** flange-mounted variable depth operating mechanisms for disconnect switches and circuit breakers
- **Eaton Cutler-Hammer** Type C361 disconnect switches and operating mechanisms, and Type C371 circuit breakers and circuit breakers operating mechanisms. Also Type SM safety handle mechanisms and Flex Shaft™ handle operators for circuit breakers
- **General Electric** Type STDA flange

handles and variable depth operating mechanisms for disconnect switches and circuit breakers. Also Spectra Flex™ cable operators for circuit breakers

- **Siemens ITE Max-Flex™** flange-mounted variable depth operating handles for disconnect switches and circuit breakers
- **Schneider Square D®** disconnect switches and circuit breakers used with Class 9422 flange-mounted variable depth operating mechanisms or cable mechanisms

These enclosures will not receive Class 9422 bracket-mounted disconnect devices, 9422TG1, or TG2 devices

Construction

- Bodies and doors are fabricated from carbon steel
- Seams are continuously welded and ground smooth
- Body stiffeners are provided for extra rigidity
- Heavy gauge continuous hinges to secure doors
- Heavy-duty 3-point padlocking handles on all doors
- 15-inch floor stands are welded to the enclosure
- Doors are sealed with a poured in place gasket
- Heavy-duty lifting eyes and provisions for lighting are provided
- Panel supports
- Collar studs are provided for mounting **optional** back panels
- Grounding provisions are provided
- Unless specified, the right door is considered to be the "Master" door on the "Right Flange" disconnect enclosures and the left door is the "Master" door on the "Center Post" disconnect enclosures

- A mechanical interlock is provided and prevents the slave door from opening before opening the master door
- Disconnects come with a universal cutout which provides mounting for most disconnect operators by using operator adapters
- Removable center post permits easy panel installation
- FTC rolled lip around all sides of the enclosure opening to exclude liquids and contaminants

Finish

- ANSI 61 gray polyester powder inside and out
- **Optional** back panels are painted with a white polyester powder
- **Optional** "G" panels are pre-galvanized steel

Accessories

- Back panels (reference table)
- See pages L1-L24
- Blank adapter plates on page G60

IMPORTANT

- Disconnect switch or circuit breakers, operating handle and operating mechanism are **not** furnished with the enclosure and must be ordered separately from the disconnect manufacturer.
- **Operator adapter plates are required** with this enclosure and must be purchased separately. See page G60 to select the proper operator adapter for the brand and type of disconnect being used
- Disconnect ordering information is located on page G30
- Review space occupied by disconnect drawings on page G29 and disconnect tables on pages G50-G59 to determine if the disconnect device you are using will fit the enclosure size you have selected

**WAX-U & WACPX-U SERIES ENCLOSURES
NEMA 12 TWO DOOR FLOOR-MOUNT DISCONNECT**

WAX-U AND WACPX-U SERIES TWO DOOR FLOOR-MOUNT DISCONNECTS

Catalog Number		Enclosure Size HxWxD	Back Panel Catalog Number*		Back Panel Size AxB*
Right Flange Mount	Center Post Mount		White	"G"	
WA60X4912U	WA60CPX4912U	60.13x49.75x12.13 (1527x1264x308)	NPDD6048	NPDD6048G	56.00x44.00 (1422x1118)
WA60X4918U	—	60.13x49.75x18.13 (1527x1264x460)	NPDD6048	NPDD6048G	56.00x44.00 (1422x1118)
WA60X4924U	WA60CPX4924U	60.13x49.75x24.13 (1527x1264x613)	NPDD6048	NPDD6048G	56.00x44.00 (1422x1118)
WA60X6112U	WA60CPX6112U	60.13x61.75x12.13 (1527x1568x308)	NPDD6060	NPDD6060G	56.00x56.00 (1422x1422)
WA60X6118U	—	60.13x61.75x18.13 (1527x1568x460)	NPDD6060	NPDD6060G	56.00x56.00 (1422x1422)
WA60X6124U	WA60CPX6124U	60.13x61.75x24.13 (1527x1568x613)	NPDD6060	NPDD6060G	56.00x56.00 (1422x1422)
WA72X6112U	—	72.13x61.75x12.13 (1832x1568x308)	NPDD7260	NPDD7260G	68.00x56.00 (1727x1422)
WA72X6118U	—	72.13x61.75x18.13 (1832x1568x460)	NPDD7260	NPDD7260G	68.00x56.00 (1727x1422)
WA72X7312U	WA72CPX7312U	72.13x73.75x12.13 (1832x1873x308)	NPDD7272	NPDD7272G	68.00x68.00 (1727x1727)
WA72X7318U	WA72CPX7318U	72.13x73.75x18.13 (1832x1873x460)	NPDD7272	NPDD7272G	68.00x68.00 (1727x1727)
WA72X7324U	—	72.13x73.75x24.13 (1832x1873x613)	NPDD7272	NPDD7272G	68.00x68.00 (1727x1727)

*Back panels must be ordered separately

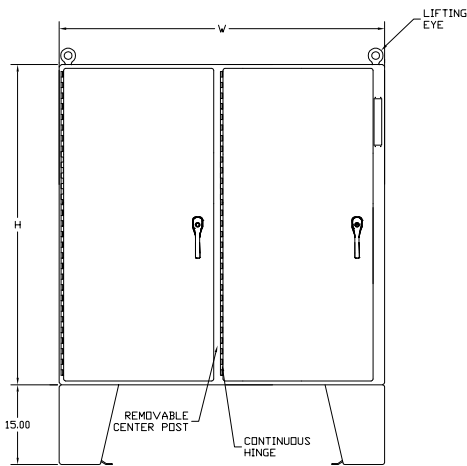

WAX-U

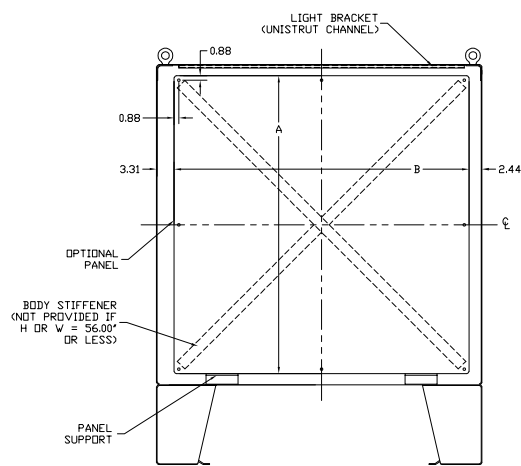

SECTION Y-Y

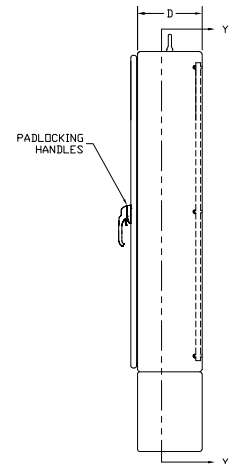

SIDE VIEW

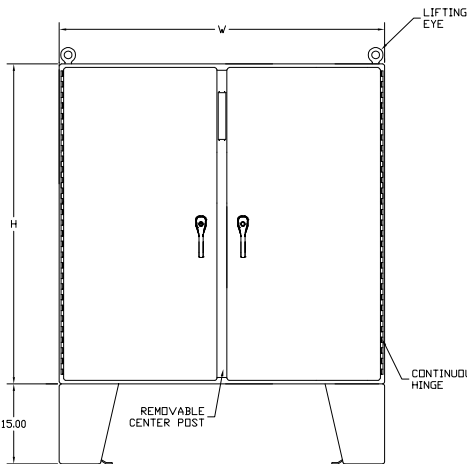

WACPX-U

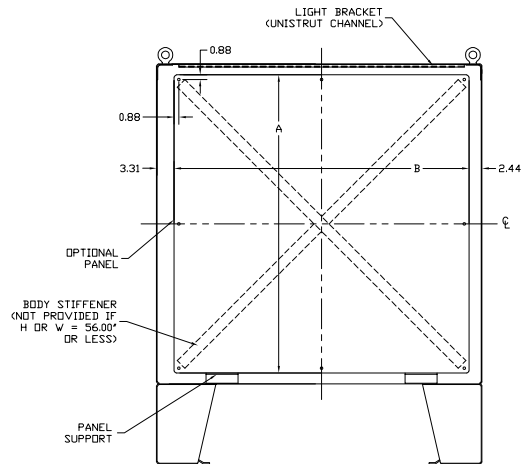

SECTION Y-Y

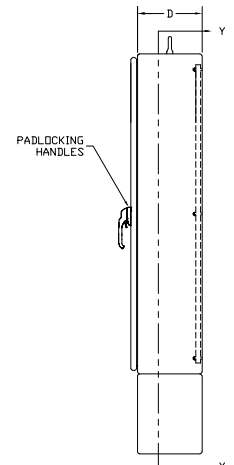

SIDE VIEW

Space Occupied by Disconnect

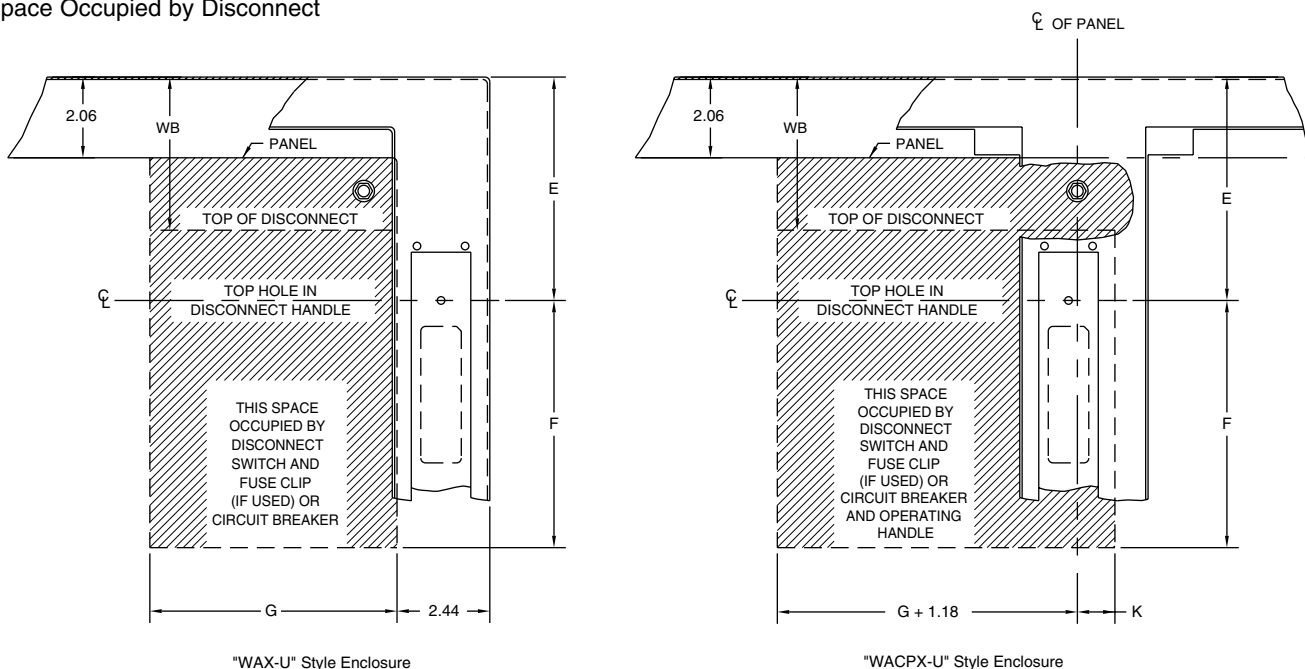

"WAX-U" Style Enclosure

"WACPX-U" Style Enclosure

Note:

1. See pages G50-G59 for various brands of disconnects for "E", "F", "G", "K" and "WB" dimensions.
2. Disconnects will occupy space on panel shown by dimensions "E", "F", "G" and "K". Wiring space "WB" is available when disconnect is installed in the enclosure.
3. When ordering 24.13 (613mm) deep enclosures, long connecting rods must be ordered. Long connecting rods are available from disconnect manufacturers.
 - ABB Controls flange-operated devices
 - Eaton Cutler-Hammer C361 devices
 - Eaton Cutler-Hammer C371 operating mechanisms C371E and C371F, order catalog number C371CS1 connecting rod. For C371G and C371K, order catalog number C371CS2 connecting rod.
 - General Electric TDA devices, order catalog number TDSR extended length drive rod
 - For Schneider Square D® 9422 devices, order catalog number 9422-R2 extra long operating rod(s). Some devices require two rods.

Refer to *National Electrical Code*® article 430-10(b) for wiring space required for line side conductors to be connected to disconnect. Verify your application to determine if wiring space is adequate.

DISCONNECT ORDERING INFORMATION

When ordering wall-mounted disconnects from the various manufacturers, be sure to order all of the necessary items. Each company has a different system, so care is required. Order the following items from the disconnect manufacturer.

Allen-Bradley

When using a Bulletin 1494F flange-mounted disconnect switch, order:

1. A disconnect switch
2. A fuse block adapter, if required
3. Line and load connectors, if required

When using a Bulletin 1494D flange-mounted operator for a circuit breaker, order:

1. A circuit breaker
2. A flange-mounted operating mechanism
3. A slide mechanism

When using a Bulletin 1494V disconnect switch, order:

- * 1. A disconnect switch
- * 2. An operating handle
- * 3. A connecting rod (long)
- * 4. A trailer fuse block kit, if required
- * 5. A fuse clip kit, if required
- 6. Line and load connectors, if required

When using a Bulletin 1494V circuit breaker operating mechanism, order:

1. A circuit breaker
2. A circuit breaker operating mechanism
3. An operating handle
4. A connecting rod (long)

An optional Allen-Bradley channel support kit is recommended when Allen-Bradley Bulletin 1494V devices are installed in 72.12" (1832mm) high enclosures with operating handle mounted on centerpost.

ABB Controls

When using a disconnect switch, order:

1. A flange operated switch (fusible or non-fusible)
2. A shaft [DSFHS-12 for 12.12" (308mm) deep or DSFHS-17 for 18.12" (460mm) deep enclosures; in 24.12" (613mm) deep enclosures a platform must be used with shaft]
3. A handle (DSFHN-HS12)

When using a circuit breaker, order:

- 1. A circuit breaker (ABB)
- * 2. An operating mechanism
- * 3. A shaft [FHS-12 for 12.12" (308mm) deep or FHS-17 for 18.12" (460mm) deep enclosures; in 24.12" (613mm) deep enclosures a platform must be used with shaft]
- * 4. Handle mechanism (FHN-HS12)

* Items available from disconnect manufacturer as complete kits.

PLEASE NOTE:

1. Various other switch accessories and circuit breaker accessories are available from disconnect manufacturers. The above information is subject to change without notice. Please contact Hubbell-Wiegmann or the disconnect manufacturer if there are further questions.
2. The "Space Occupied" tables (pages G50-G59) are based upon information supplied by disconnect manufacturers. Hubbell-Wiegmann does not assume responsibility for the accuracy of these dimensions.

Eaton Cutler-Hammer

When using a Type C361 disconnect switch, order:

- * 1. A disconnect switch with an operating mechanism
- * 2. An operating handle (C361H1 or C361H3)

When using a Type C371 circuit breaker operating mechanism with a circuit breaker, order:

1. A circuit breaker
- * 2. An operating mechanism
- * 3. An operating handle

When using a Type SM handle mechanism, order:

1. A circuit breaker
2. A type SM handle mechanism

When using a Flex Shaft™ handle mechanism, order:

1. A circuit breaker
2. A complete Flex Shaft™ handle mechanism

General Electric

When using a disconnect switch, order:

1. A disconnect switch (Type QMR or QMW)
2. A fuse clip kit or no-fuse kit
3. A flange handle (STDA1 or STDA2)
4. A variable depth operating mechanism
5. An extended length drive rod (if required)

When using a circuit breaker, order:

1. A circuit breaker
2. A flange handle (STDA1 or STDA2)
3. A variable depth operating mechanism
4. An extended length drive rod (if required)

When optional General Electric Flange Stiffener Kit (catalog number TDSR) is recommended when General Electric Type TDA devices are installed in 72.12" (1832) high enclosures with operating handle mounted on centerpost. Use with TDOM1, TDOM2, TDOM3, S100M1A, and S100M3 operating mechanisms.

When using a circuit breaker with a Spectra Flex™ cable operator, order:

1. A circuit breaker
2. A flange-mounted handle mechanism
3. A breaker-mounted mechanism
4. An operating cable

Siemens ITE Max-Flex™

When using a disconnect switch, order:

1. A basic switch (right-hand)
2. A fuse or no-fuse kit
- * 3. FHOHS flange-mounted handle
- * 4. Switch operator
- * 5. FHOECO36 cable for 12.12" (308mm) deep enclosures or FHOECO48 for 18.12 (460mm) and 24.12" (613mm) deep enclosures

When using a circuit breaker, order:

1. A circuit breaker
2. Pressure wire connectors
- * 3. A flange-mounted handle
- * 4. A circuit breaker operator mechanism
- * 5. An operating cable [12.12" (308mm) deep or 18.12 (460mm) deep enclosures accept 36.00" (914mm) or 48.00 (1219mm) cables; 24.12" (613mm) deep enclosures require a 48.00" (1219mm) cable]

* These items are available from Siemens ITE Max-Flex™ ITE as a complete mechanism with a 36.00" (914mm) operating cable only. Order items separately when using a 48.00" (1219mm) operating cable.

Schneider Square D®

When using a disconnect switch, order:

1. A disconnect switch with operating mechanism
2. A universal handle mechanism
3. A long operating rod, if required

When using a circuit breaker, order:

1. A circuit breaker
2. An operating mechanism
3. A universal handle mechanism
4. A long operating rod, if required

When using a Class 9422 Type "T" disconnect switch with a cable mechanism, order:

1. A disconnect switch with operating mechanism (Class 9422 Type T)
2. A handle mechanism (Class 9422 Type A-1)
3. A cable mechanism (Class 9422 CFT_O) 3-, 5-, or 10-foot

When using a circuit breaker with a cable mechanism, order:

1. A circuit breaker (Schneider Square D®)
2. A handle mechanism (Class 9422 Type A-1)
3. A cable mechanism (Class 9422 CFT_O) 3-, 5-, or 10-foot

An optional Schneider Square D® Channel Flange Support Kit (catalog number 9422-C1) is recommended when some Schneider Square D® devices are installed in 72.12" (1832mm) high enclosures with operating handle mounted on centerpost.



WA72XM2718U

Industry Standards

UL 508A, Type 12
CSA Certified, Type 12
NEMA/EEMAC Type 12

 UL File E64791

 CSA File LL66078

FEATURES-SPECIFICATIONS

Applications

The Wiegmann universal cutout is used in large freestand and floorstand enclosures. Operator Adapter Kits are required in order to install the various manufacturers' hardware. Note that 400 A (or greater) disconnect switches and 600 A (or greater) circuit breakers need to use the "Large" or "High Amp" cutout, which is provided in the WA21ABVA kit for Allen-Bradley variable-depth disconnect switches or the WA21ITE kit for Siemens (and select other manufacturers) flex-cable devices. The "Large" or "High Amp" cutout accepts the larger operating handle whose mounting hole centers are 6.500-in. apart.

Allen-Bradley

- 1494V disconnect switches with flange-mount variable depth operating mechanisms and 1494V flange-mounted variable depth operating mechanisms for circuit breakers
- 140U flexible cable operating mechanisms and 140U molded case circuit breakers
- 1494C cable-operated disconnect switches with flange-mount handles
- 194RC cable-operated flange-mount handles for use with the NFPA 79 compliant 194R IEC rotary disconnect switches

Allen-Bradley 1494V-R1, -R2 and -W2 operating handles and Allen-Bradley 1494F disconnect devices or 1494D circuit breaker operators will NOT fit these enclosures.

- **ABB Controls** flange-mounted variable depth operating mechanisms for disconnect switches and circuit breakers
- **Eaton Cutler-Hammer** Type C361 disconnect switches and operator mechanisms. Eaton Cutler-Hammer Type C371 circuit breaker operating mechanisms. Also Type SM safety handle mechanisms and Flex Shaft™ handle operators for circuit breakers

- **General Electric** Type STDA flange handles and variable depth operating mechanisms for disconnect switches and circuit breakers. Also Spectra Flex™ cable operators for circuit breakers
- **Siemens ITE Max-Flex™** flange-mounted variable depth operating handles for disconnect switches and circuit breakers
- **Schneider Square D®** disconnect switches and circuit breakers used with Class 9422 flange-mounted variable depth operating mechanisms or cable mechanism

These enclosures will not receive Class 9422 bracket-mounted disconnect devices or Class 9422TG1 or TG2 devices

Construction

- Bodies and doors are fabricated from carbon steel.
- Removable back panels are included and mounted on collar studs
- Seams are continuously welded and ground smooth
- Body stiffeners are provided for extra rigidity
- Heavy-duty lifting eyes and provisions for lighting are provided
- Heavy gauge continuous hinges support each door
- 3-point padlocking handles on all doors
- Panel supports
- Center posts are removable to permit easy panel installation.
- Grounding provisions are provided
- Doors are sealed with a poured in place gasket
- Unless specified, the far right door is considered to be the "Master" door. All other doors are considered slave doors

- The mechanical interlock is activated by the master door which prevents the slave doors from being opened first. Doors can be closed in any order
- Disconnects come with a universal cut-out which provides mounting for most disconnect operators by using operator adapters
- FTC rolled lip around all sides of the enclosure opening excludes liquids and contaminants

Finish

- ANSI 61 gray polyester powder inside and out
- Included back panels are painted with a white polyester powder

Accessories

- See pages L1-L24
- Blank adapter plates on page G60

IMPORTANT

- Disconnect switch circuit breakers, operating handle and operating mechanism are not furnished with the enclosure and must be ordered separately from the disconnect manufacturer
- Operator adapter plates are required with this enclosure and must be purchased separately. See page G60 to select the proper operator adapter for the brand and type of disconnect being used
- Disconnect ordering information is located on page G38
- Review space occupied by disconnect drawings on page G37 and disconnect tables on pages G50-G59 to determine if the disconnect device you are using will fit the enclosure size you have selected

**WAXM-U SERIES ENCLOSURES
NEMA 12 HEAVY-DUTY FREESTANDING DISCONNECT**

WAXM-U SERIES HEAVY-DUTY SINGLE DOOR DISCONNECT

Catalog Number	Enclosure Size HxWxD	Back Panel Size AxB*
WA72XM2718U	72.13x27.50x18.13 (1832x699x460)	60.00x21.75 (1524x552)
WA72XM3318U	72.13x33.50x18.13 (1832x851x460)	60.00x27.75 (1524x705)
WA72XM3918U	72.13x39.50x18.13 (1832x1003x460)	60.00x33.75 (1524x857)
WA84XM3918U	84.13x39.50x18.13 (2137x1003x460)	72.00x33.75 (1829x857)
WA90XM3920U	90.13x39.50x20.13 (2289x1003x511)	78.00x33.75 (1981x857)
WA90XM3924U	90.13x39.50x24.13 (2289x1003x613)	78.00x33.75 (1981x857)

*Back panels are furnished with enclosures.

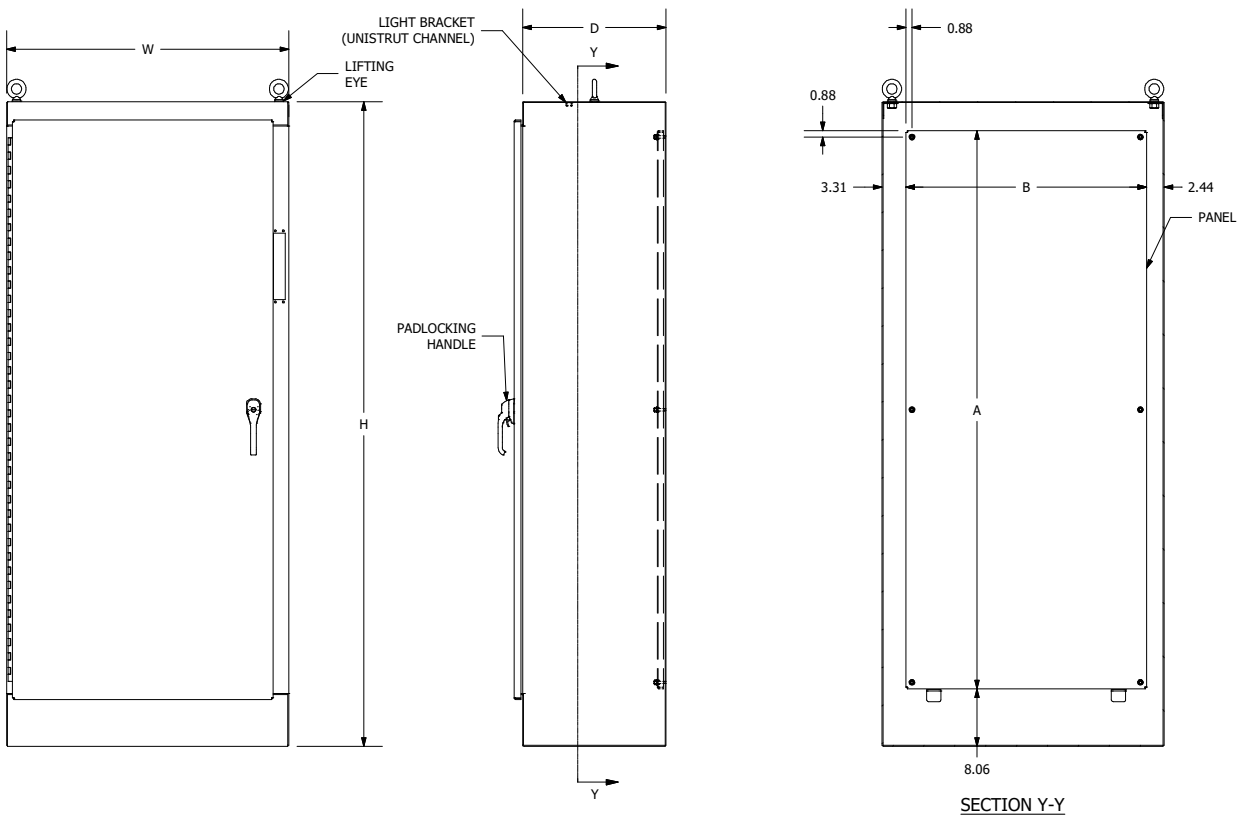

WAXM-U SERIES ENCLOSURES NEMA 12 HEAVY-DUTY FREESTANDING DISCONNECT

G33

WAXM-U SERIES HEAVY-DUTY TWO DOOR DISCONNECT

Catalog Number	Enclosure Size HxWxD	Back Panel Size AxB*
WA72XM5318U	72.13x54.30x18.13 (1832x1365x460)	60.00x48.00 (1524x1219)
WA72XM6518U	72.13x66.50x18.13 (1832x1670x460)	60.00x60.00 (1524x1524)
WA72XM7718U	72.13x78.50x18.13 (1832x1975x460)	60.00x72.00 (1524x1829)
WA72XM7724U	72.13x78.50x24.13 (1832x1975x613)	60.00x72.00 (1524x1829)
WA84XM7718U	84.13x78.50x18.13 (2137x1975x461)	72.00x72.00 (1829x1829)
WA90XM7720U	90.13x78.50x20.13 (2289x1975x511)	78.00x72.00 (1981x1829)
WA90XM7724U	90.13x78.50x24.13 (2289x1975x613)	78.00x72.00 (1981x1829)

*Back panels are furnished with enclosures.

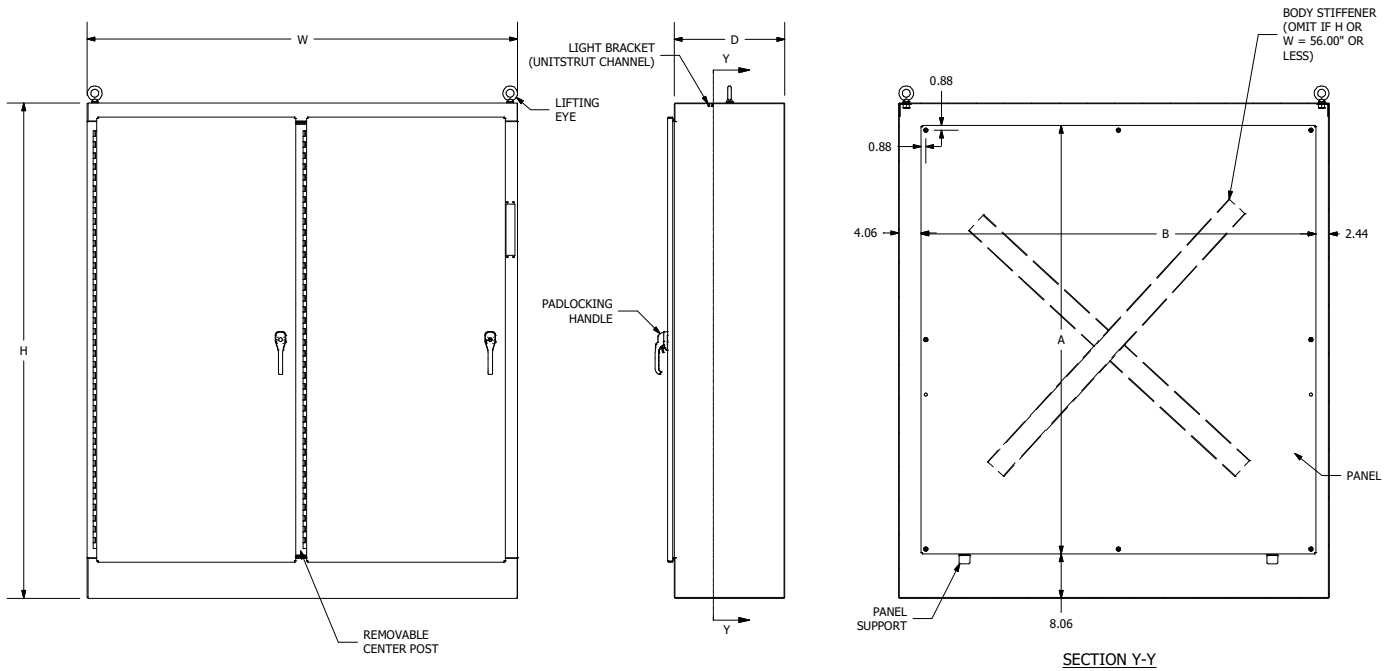

WAXM-U SERIES ENCLOSURES NEMA 12 HEAVY-DUTY FREESTANDING DISCONNECT

WAXM-U SERIES HEAVY-DUTY THREE DOOR DISCONNECT

Catalog Number	Enclosure Size HxWxD	Number of Panels	Back Panel Size AxB*
WA72XM3EW18U	72.13x99.50x18.13 (1832x2527x460)	1 1	60.00x60.00 (1524x1524) 60.00x27.75 (1524x705)
WA72XM3EW18U	72.13x117.50x18.13 (1832x2985x460)	1 1	60.00x72.00 (1524x1829) 60.00x33.75 (1524x857)
WA84XM3EW18U	84.13x117.50x18.13 (2137x2985x460)	1 1	72.00x72.00 (1829x1829) 72.00x33.75 (1829x857)
WA90XM3EW24U	90.13x117.50x24.13 (2289x2985x613)	1 1	78.00x72.00 (1981x1829) 78.00x33.75 (1981x857)

*Back panels are furnished with enclosures.

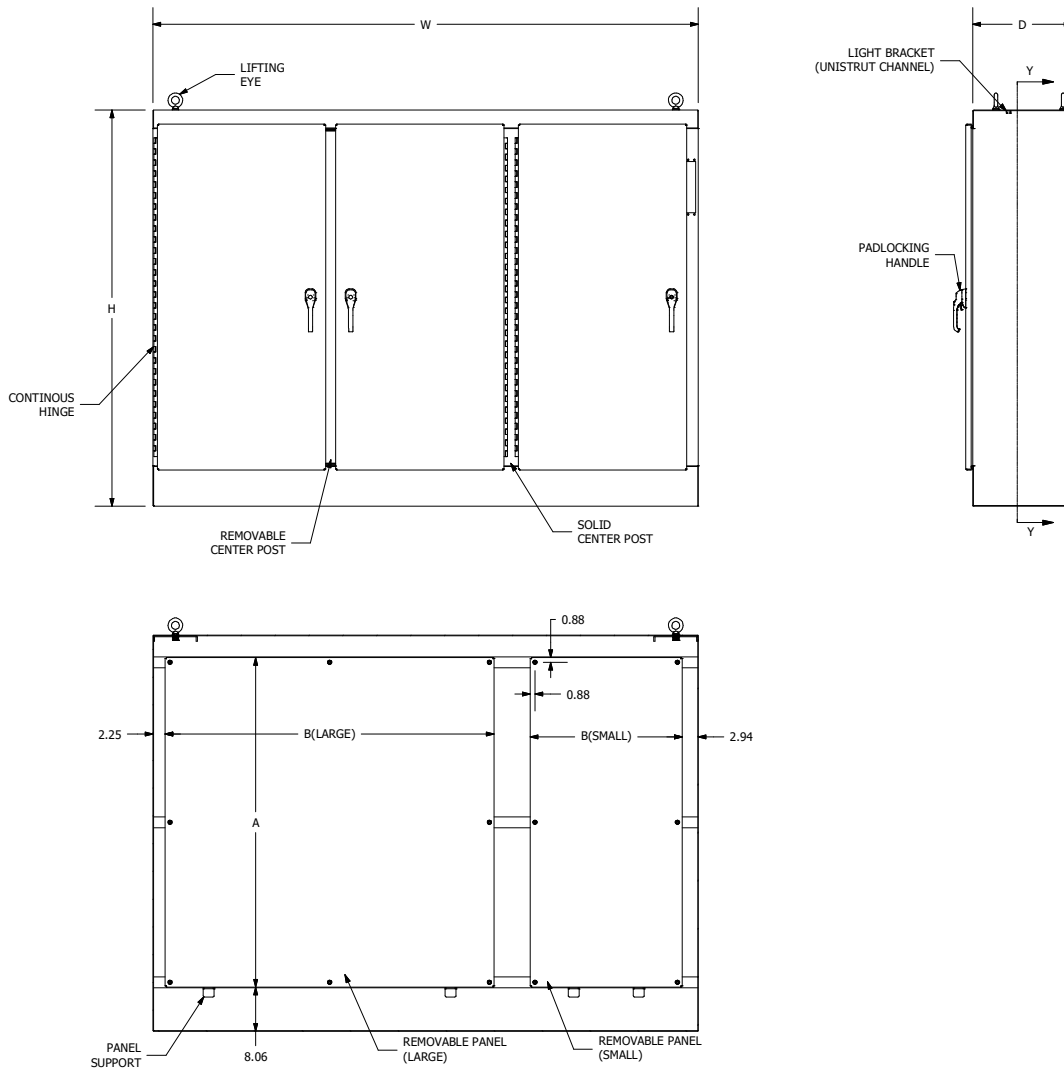

WAXM-U SERIES ENCLOSURES NEMA 12 HEAVY-DUTY FOUR DOOR FREESTANDING DISCONNECT

G35

WAXM-U SERIES HEAVY-DUTY FOUR DOOR DISCONNECT

Catalog Number	Enclosure Size HxWxD	Number of Panels	Back Panel Size AxB*
WA84XM4EW18U	84.13x157.50x18.13 (2137x4001x461)	2	72.00x72.00 (1829x1829)

*Back panels are furnished with enclosures.

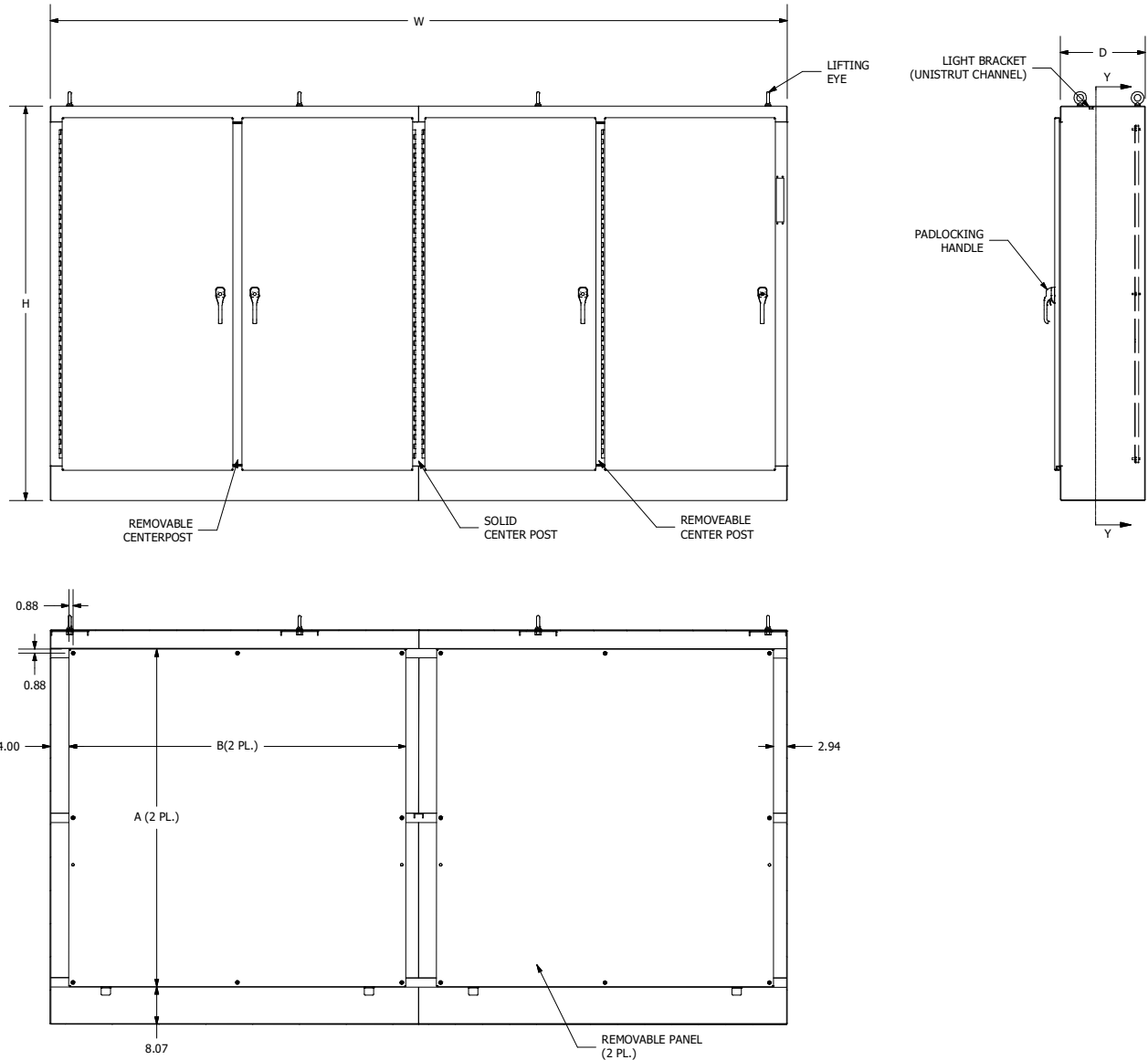

**WAXM-U SERIES ENCLOSURES
NEMA 12 HEAVY-DUTY FREESTANDING FIVE DOOR DISCONNECT**

WAXM-U SERIES HEAVY-DUTY FIVE DOOR DISCONNECT

Catalog Number	Enclosure Size HxWxD	Number of Panels	Back Panel Size AxB*
WA84XM5EW18U	84.13x196.75x18.13 (2137x4997x460)	2 1	72.00x72.00 (1829x1829) 72.00x33.75 (1829x857)

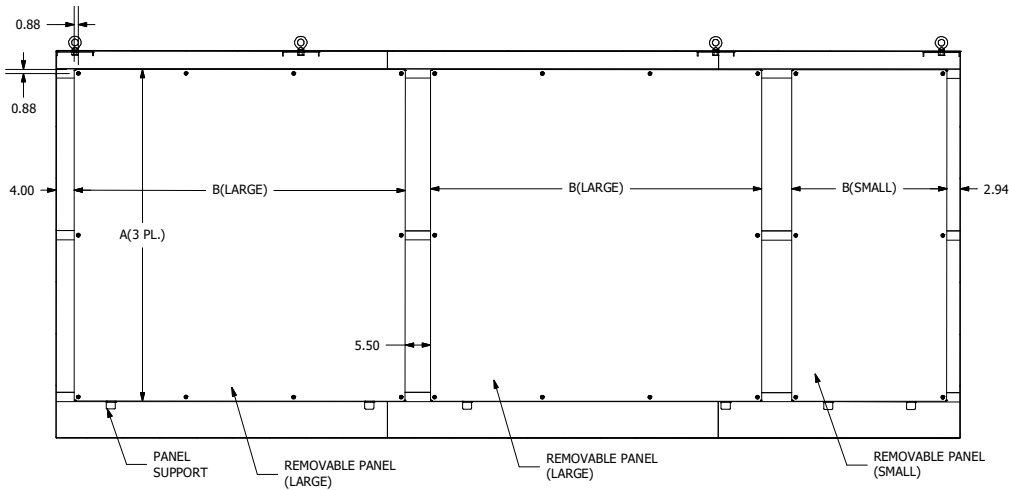
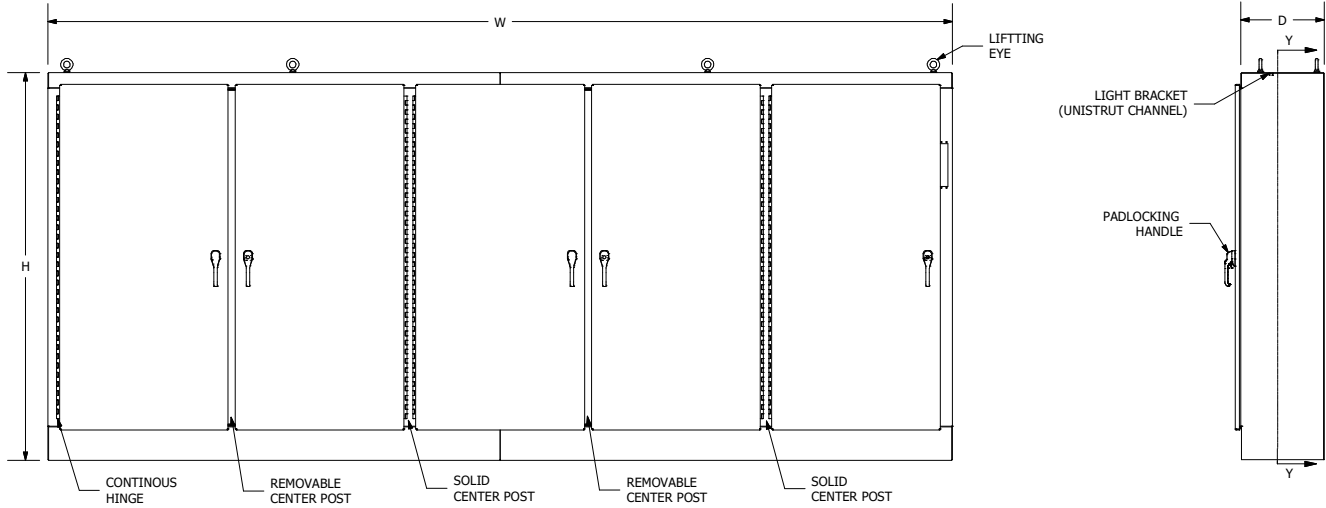

Space Occupied by Disconnect

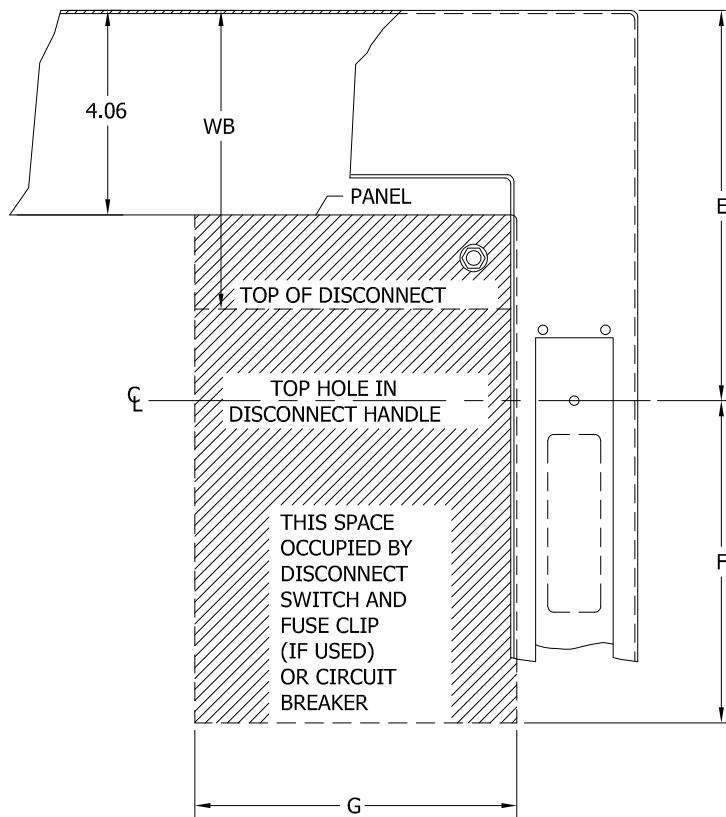

Notes:

1. See pages G50-G59 for various brands of disconnects for "E", "F", "G", and "WB" dimensions.
2. Disconnects will occupy space on panel shown by dimensions "E", "F" and "G". Wiring space "WB" is available when disconnect is installed in the enclosure.
3. When ordering 24.13 (613mm) deep enclosures, long connection rods must be ordered. Long connecting rods are available from disconnect manufacturers.
 - ABB Controls flange-operated devices
 - Cutler-Hammer C361 devices
 - Cutler-Hammer C371 operating mechanisms C371E and C371F, order catalog number C371CS1 connecting rod. For C371G and C371K, order catalog number C371CS2 connection rod.
 - General Electric TDA devices, order catalog number TDSR extended length drive rod.
 - For Schneider Square D® 9422 devices, order catalog number 9422-R2 extra long operating rod(s). Some devices require two rods.

Refer to National Electrical Code® 1996 article 430-10(b) for wiring space required for line side conductors to be connected to disconnect. Verify your application to determine if wiring space is adequate.

DISCONNECT ORDERING INFORMATION

When ordering wall-mounted disconnects from the various manufacturers, be sure to order all of the necessary items. Each company has a different system, so care is required. Order the following items from the disconnect manufacturer.

Allen-Bradley

When using a Bulletin 1494F flange-mounted disconnect switch, order:

1. A disconnect switch
2. A fuse block adapter, if required
3. Line and load connectors, if required

When using a Bulletin 1494D flange-mounted operator for a circuit breaker, order:

1. A circuit breaker
2. A flange-mounted operating mechanism
3. A slide mechanism

When using a Bulletin 1494V disconnect switch, order:

- *1. A disconnect switch
- *2. An operating handle
- *3. A connecting rod (long)
- *4. A trailer fuse block kit, if required
- *5. A fuse clip kit, if required
6. Line and load connectors, if required

When using a Bulletin 1494V circuit breaker operating mechanism, order:

1. A circuit breaker
2. A circuit breaker operating mechanism
3. An operating handle
4. A connecting rod (long)

ABB Controls

When using a disconnect switch, order:

1. A flange operated switch (fusible or non-fusible)
2. A shaft [DSFHS-17 for 18.12" (460mm) deep or DSFHS-22 for 20.12" (511mm) deep enclosures; in 24.12" (613mm) deep enclosures a platform must be used with shaft]
3. A handle (DSFHN-HS12)

When using a circuit breaker, order:

1. A circuit breaker (ABB)
- *2. An operating mechanism
- *3. A shaft [FHS-17 for 18.12" (460mm) deep or FHS-22 for 20.12" (511mm) deep enclosures; in 24.12" (613mm) deep enclosures a platform must be used with shaft]
- *4. Handle mechanism (FHN-HS12)

PLEASE NOTE:

1. Various other switch accessories and circuit breaker accessories are available from disconnect manufacturers. The above information is subject to change without notice. Please contact Hubbell-Wiegmann or the disconnect manufacturer if there are further questions.
2. The "Space Occupied" tables (pages G50-G59) are based upon information supplied by disconnect manufacturers. Hubbell-Wiegmann does not assume responsibility for the accuracy of these dimensions.

* Items available from disconnect manufacturer as complete kits.

Eaton Cutler-Hammer

When using a Type C361 disconnect switch, order:

- *1. A disconnect switch with an operating mechanism
- *2. An operating handle (C361H1 or C361H3)

When using a Type C371 circuit breaker operating mechanism with a C-H order:

1. A circuit breaker
- *2. An operating mechanism
- *3. An operating handle

When using a Type SM handle mechanism, order:

1. A circuit breaker
2. A type SM handle mechanism

When using a Flex Shaft™ handle mechanism, order:

1. A circuit breaker
2. A complete Flex Shaft™ handle mechanism

General Electric

When using a disconnect switch, order:

1. A disconnect switch (Type QMR or QMW)
2. A fuse clip kit or no-fuse kit
3. A flange handle (STDA1 or STDA2)
4. A variable depth operating mechanism
5. An extended length drive rod (if required)

When using a circuit breaker, order:

1. A circuit breaker
2. A flange handle (STDA1 or STDA2)
3. A variable depth operating mechanism
4. An extended length drive rod (if required)

When using a circuit breaker with a Spectra Flex™ cable operator, order:

1. A circuit breaker
2. A flange-mounted handle mechanism
3. A breaker-mounted mechanism
4. An operating cable

Siemens ITE Max-Flex™

When using a disconnect switch, order:

1. A basic switch (right-hand)
2. A fuse or no-fuse kit
- *3. FHOHS flange-mounted handle
- *4. Switch operator
- *5. FHOECO48 cable

When using a circuit breaker, order:

1. A circuit breaker
2. Pressure wire connectors
- *3. A flange-mounted handle
- *4. A circuit breaker operator mechanism
- *5. An operating cable [18.12" (460mm) deep or 20.12" (511mm) deep enclosures accept 36.00" (914mm) or 48.00" (1219mm) cables; 24.12" (613mm) deep enclosures require a 48.00" (1219mm) cable]

* These items are available from Siemens ITE Max-Flex™ as a complete mechanism with a 36.00" (914mm) operating cable only. Order items separately when using a 48.00" (1219mm) operating cable.

Schneider Square D®

When using a disconnect switch, order:

1. A disconnect switch with operating mechanism
2. A universal handle mechanism
3. A long operating rod, if required

When using a circuit breaker, order:

1. A circuit breaker
2. An operating mechanism
3. A universal handle mechanism
4. A long operating rod, if required

When using a Class 9422 Type "T" disconnect switch with a cable mechanism, order:

1. A disconnect switch with operating mechanism (Class 9422 Type T)
2. A handle mechanism (Class 9422 Type A-1)
3. A cable mechanism (Class 9422 CFT_O) 3-, 5-, or 10-foot

When using a circuit breaker with a cable mechanism, order:

1. A circuit breaker (Schneider Square D®)
2. A handle mechanism (Class 9422 Type A-1)
3. A cable mechanism (Class 9422 CFT_O) 3-, 5-, or 10-foot



WMOB72X4018U

Industry Standards
 UL 508A, Type 12
 CSA Certified, Type 12
 NEMA/EEMAC Type 12

 UL File E64791

 CSA File LL66078

FEATURES-SPECIFICATIONS

Applications

Modular single door and double door Modular free standing enclosures are designed to be bolted together in a variety of lengths and combinations to meet the customer's specific application. Modular disconnects enclosures are designed to house the following flange-mounted disconnect switches and circuit breakers:

The Wiegmann universal cutout is used in large freestanding and floorstand enclosures. Operator Adapter Kits are required in order to install the various manufacturers' hardware. Note that 400 A (or greater) disconnect switches and 600 A (or greater) circuit breakers need to use the "Large" or "High Amp" cutout, which is provided in the WA21ABVA kit for Allen-Bradley variable-depth disconnect switches or the WA21ITE kit for Siemens ITE Max-Flex™ (and select other manufacturers) flex-cable devices. The "Large" or "High Amp" cutout accepts the larger operating handle whose mounting hole centers are 6.500-in. apart.

Allen-Bradley

- 1494V disconnect switches with flange-mount variable depth operating mechanisms and 1494V flange-mounted variable depth operating mechanisms for circuit breakers
- 140U flexible cable operating mechanisms and 140U molded case circuit breakers
- 1494C cable-operated disconnect switches with flange-mount handles
- 194RC cable-operated flange-mount handles for use with the NFPA 79 compliant 194R IEC rotary disconnect switches

Allen-Bradley 1494V-R1, -R2 and -W2 operating handles and Allen-Bradley 1494F disconnect devices or 1494D circuit breaker operators will NOT fit these enclosures.

- **ABB Controls** flange-mounted variable depth operating mechanisms for disconnect switches and circuit breakers
- **Eaton Cutler-Hammer** Type C361 disconnect switches and operating mechanisms, and Type C371 circuit breaker operating mechanisms. Also Type SM safety handle

mechanisms and Flex Shaft™ handle operators for circuit breakers

- **General Electric** Type STDA flange handles and variable depth operating mechanisms for disconnect switches and circuit breakers. Also Spectra Flex™ cable operators for circuit breakers
- **Siemens ITE Max-Flex™** flange-mounted variable depth operating handles for disconnect switches and circuit breakers
- **Schneider Square D®** disconnect switches and circuit breakers used with Class 9422 flange-mounted variable depth operating mechanisms or cable mechanisms
These enclosures will not receive Schneider Square D® Class 9422 bracket-mounted disconnect devices or Class 9422TG1 or TG2 devices.

Construction

- Bodies and doors are fabricated from carbon steel
- Removable back panels are included and mounted on collar studs
- Seams are continuously welded and ground smooth
- Body stiffeners are provided for extra rigidity
- Door and side openings are flanged to provide extra strength and smooth edges
- Heavy-duty lifting eyes
- Heavy gauge continuous hinges
- Grounding provisions are provided
- 3-point padlocking handle on all doors
- Doors are sealed with a poured in place gasket
- Mechanical interlocks come standard on each enclosure. Parts required to connect interlock system between adjacent enclosures are provided

Finish

- ANSI 61 gray polyester powder inside and out
- Back panels are painted with a white polyester powder

Accessories

- See pages L1-L24
- Blank adapter plates on page G60

IMPORTANT

- Disconnect switch circuit breakers, operating handle and operating mechanism are not furnished with the enclosures and must be ordered separately from the disconnect manufacturer
- **Operator adapter plates are required** with the modular flange disconnect enclosure only and must be purchased separately. Modular non-disconnect enclosures do not require a operator adapter plate. See page G60 to select the proper operator adapter for the brand and type of disconnect being used
- Disconnect ordering information is located on page G43
- Review space occupied by disconnect drawings on page G42 and disconnect tables on pages G50-G59 to determine if the disconnect device you are using will fit the enclosure size you have selected

A modular enclosure system consists of:

- A disconnect (master) enclosure
- Any quantity of slave enclosures
- Gasket kits to be used between enclosures
- End plate
- An operator adapter plate or blank adapter plate
- Disconnect device (order from disconnect manufacturer)

Single and Two Door Master Enclosures

- Left side is open (see drawings on pages G40 and G41)
- Master door hinged on left
- Master door activates mechanical interlock which prevents slave enclosures from being opened first
- Doors may be closed in any order

Single and Two Door Slave Enclosures

- Both sides are open (see drawings on pages G40 and G41)
- Door cannot be opened until master enclosure is opened or the interlock is defeated

WMOD SERIES ENCLOSURES NEMA 12 MODULAR FREESTANDING DISCONNECT

WMOD SERIES SINGLE DOOR MODULAR FLANGE DISCONNECT (LEFT SIDE OPEN)

Catalog Number	Enclosure Size HxWxD	Back Panel Size AxB*
WMOD72X4018U	72.13x39.75x18.13 (1832x1010x460)	60.00x33.75 (1524x857)
WMOD84X4018U	84.13x39.75x18.13 (2137x1010x460)	72.00x33.75 (1829x857)
WMOD84X4024U	84.13x39.75x24.13 (2137x1010x613)	72.00x33.75 (1829x857)

WMOD SERIES SINGLE DOOR MODULAR NON-DISCONNECT (BOTH SIDES OPEN)

Catalog Number	Enclosure Size HxWxD	Back Panel Size AxB*
WMOD723818	72.13x38.75x18.13 (1832x984x460)	60.00x33.75 (1524x857)
WMOD843818	84.13x38.75x18.13 (2137x984x460)	72.00x33.75 (1829x857)
WMOD843824	84.13x38.75x24.13 (2137x984x613)	72.00x33.75 (1829x857)

*Back panels are furnished with enclosures.

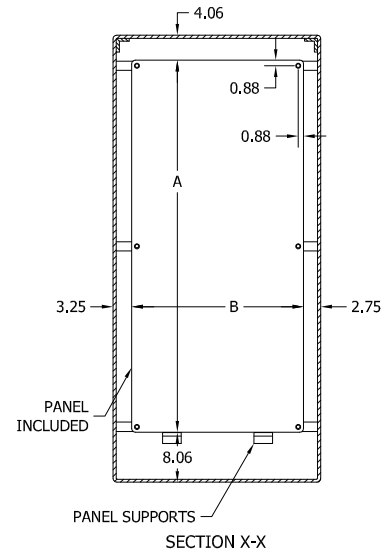
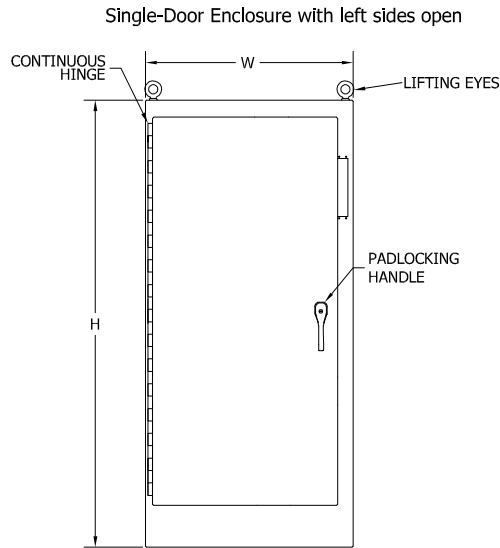
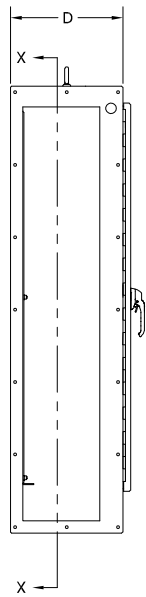

Single-Door Enclosure with both sides open

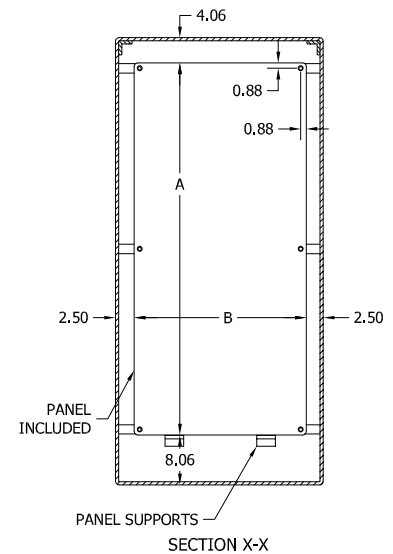
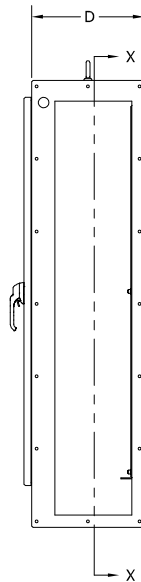
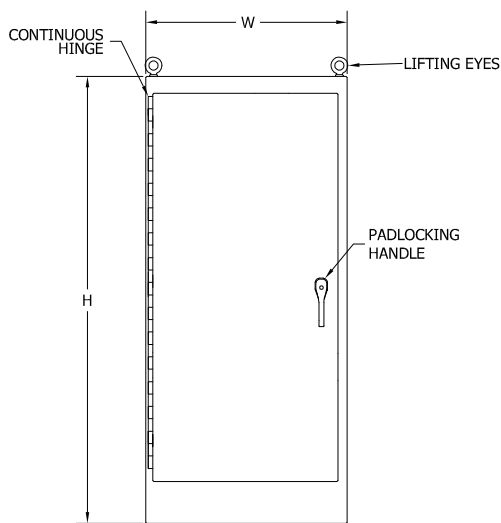

WMOD SERIES TWO DOOR MODULAR RIGHT FLANGE DISCONNECT (LEFT SIDE OPEN)

Catalog Number	Enclosure Size HxWxD	Back Panel Size AxB*
WMOD72X7818U	72.13x77.00x18.13 (1832x1956x460)	60.00x72.00 (1524x1829)
WMOD84X7818U	84.13x77.00x18.13 (2137x1956x460)	72.00x72.00 (1829x1829)
WMOD84X7824U	84.13x77.00x24.13 (2137x1956x613)	72.00x72.00 (1829x1829)

*Back panels are furnished with enclosures.

WMOD SERIES TWO DOOR MODULAR NON-DISCONNECT (BOTH SIDES OPEN)

Catalog Number	Enclosure Size HxWxD	Back Panel Size AxB*
WMOD727718	72.13x77.00x18.13 (1832x1956x460)	60.00x72.00 (1524x1829)
WMOD847718	84.13x77.00x18.13 (2137x1956x460)	72.00x72.00 (1829x1829)
WMOD847724	84.13x77.00x24.13 (2137x1956x613)	72.00x72.00 (1829x1829)

*Back panels are furnished with enclosures.

Two-Door Right Flange Disconnect with left side open

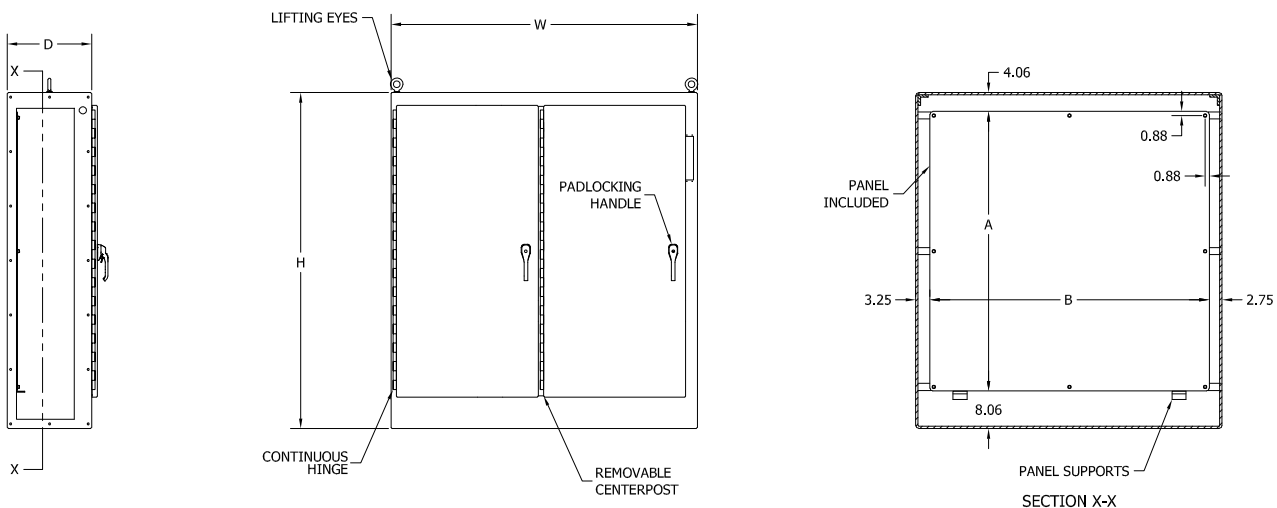

Two-Door enclosure with both sides open

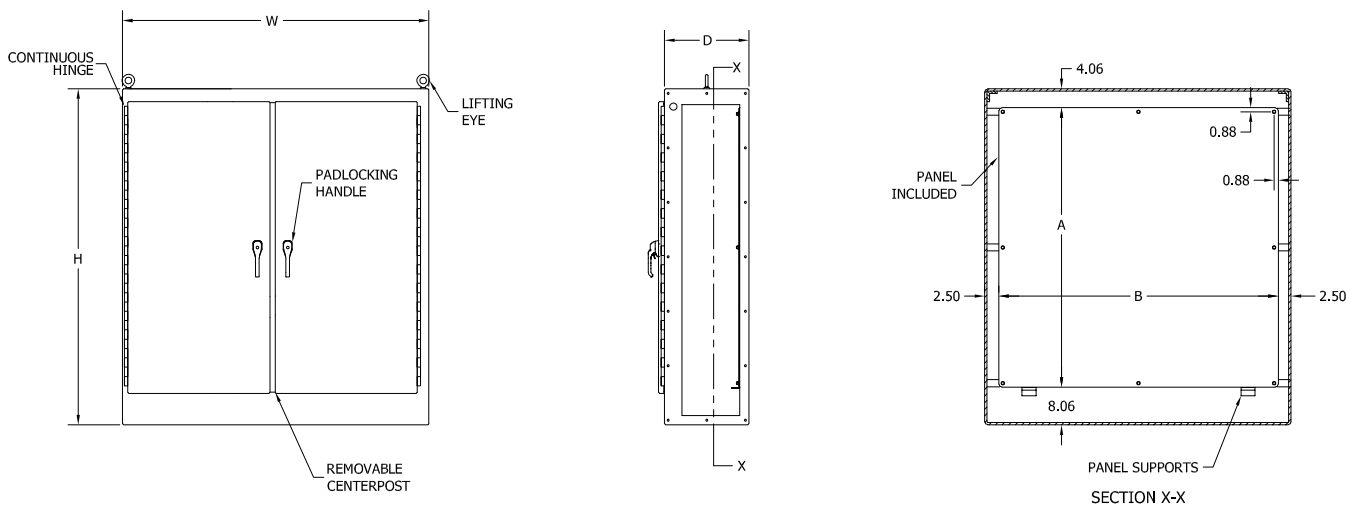

WMOD SERIES ENCLOSURES NEMA 12 MODULAR FREESTANDING DISCONNECT

ACCESSORIES FOR MODULAR WMOD SERIES NEMA 12 FLANGE-MOUNTED DISCONNECT

Catalog Number	Body/Door Steel Gauge	Size HxD (See Drawing Below)
WMOD7218EPT	Formed end plate with gasket and bolts	72.13x18.13 (1832x460)
WMOD7218FTPT	Flat end plate with gasket and bolts	72.00x18.50 (1829x470)
WMOD7218GK	Gasket kit with gasket and bolts	72.00x18.00 (1829x457)
WMOD8418EPT	Formed end plate with gasket and bolts	84.13x18.13 (2137x460)
WMOD8424EPT	Formed end plate with gasket and bolts	84.13x24.13 (2137x613)
WMOD8418FTPT	Flat end plate with gasket and bolts	84.00x18.50 (2134x470)
WMOD8424FTPT	Flat end plate with gasket and bolts	84.00x24.50 (2134x622)
WMOD8418GK	Gasket kit with gasket and bolts	84.00x18.00 (2134x457)
WMOD8424GK	Gasket kit with gasket and bolts	84.00x24.00 (2134x610)

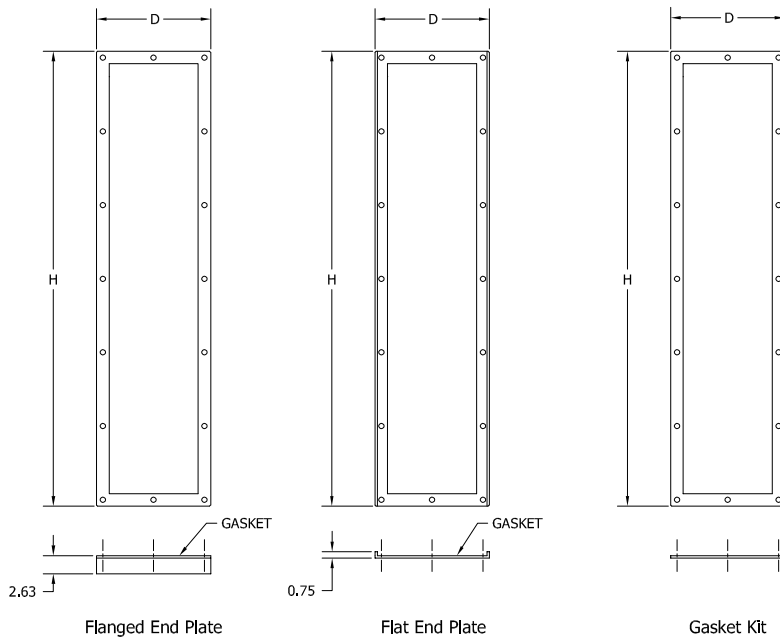

End Plates

Used to seal open end(s) of an assembly of modular enclosures. End plates are available in two types:

- The 2.63" thick End Plates allow extra wiring space. The end plate includes a gasket and mounting bolts.
- The Flat End Plate provides a low profile cover for the open end of a modular enclosure. The flat end plate includes gasket and mounting bolts.

Gasket Kit

Used to join modular enclosures together, includes gasket and mounting hardware.

Space Occupied by Disconnect

Notes:

1. See pages G50-G59 for various brands of disconnects for "E", "F", "G", and "WB" dimensions.
2. Disconnects will occupy space on panel shown by dimension "E", "F", and "G". Wiring space "WB" is available when disconnect is installed in the enclosure.
3. When ordering 24.13 (613mm) deep enclosures, long connecting rods must be ordered. Long connecting rods are available from disconnect manufacturers.
 - ABB Controls flange-operated devices
 - Cutler-Hammer C361 devices
 - Cutler-Hammer C371 operating mechanisms C371E and C371F, order catalog number C371CS1 connecting rod. For C371G and C371K, order catalog number C371CS2 connecting rod.
 - General Electric TDA devices, order catalog number TDSR extended length drive rod.
 - For Schneider Square D® 9422 devices, order catalog number 9422-R2 extra long operating rod(s). Some devices require two rods.

Refer to National Electrical Code® article 430-10(b) for wiring space required for line side conductors to be connected to disconnect. Verify your application to determine if wiring space is adequate.

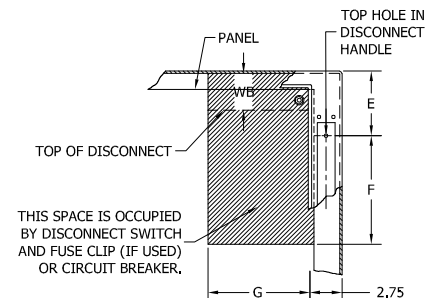

DISCONNECT ORDERING INFORMATION

When ordering wall-mounted disconnects from the various manufacturers, be sure to order all of the necessary items. Each company has a different system, so care is required. Order the following items from the disconnect manufacturer.

Allen-Bradley

When using a Bulletin 1494F flange-mounted disconnect switch, order:

1. A disconnect switch
2. A fuse block adapter, if required
3. Line and load connectors, if required

When using a Bulletin 1494D flange-mounted operator for a circuit breaker, order:

1. A circuit breaker
2. A flange-mounted operating mechanism
3. A slide mechanism

When using a Bulletin 1494V disconnect switch, order:

- *1. A disconnect switch
- *2. An operating handle
- *3. A connecting rod (long)
- *4. A trailer fuse block kit, if required
- *5. A fuse clip kit, if required
6. Line and load connectors, if required

When using a Bulletin 1494V circuit breaker operating mechanism, order:

1. A circuit breaker
2. A circuit breaker operating mechanism
3. An operating handle
4. A connecting rod (long)

ABB Controls

When using a disconnect switch, order:

1. A flange operated switch (fusible or non-fusible)
2. A shaft [DSFHS-17 for 18.12" (460mm) deep or DSFHS-22 for 20.12" (511mm) deep enclosures; in 24.12" (613mm) deep enclosures a platform must be used with shaft]
3. A handle (DSFHN-HS12)

When using a circuit breaker, order:

1. A circuit breaker (ABB)
- *2. An operating mechanism
- *3. A shaft [FHS-17 for 18.12" (460mm) deep or FHS-22 for 20.12" (511mm) deep enclosures; in 24.12" (613mm) deep enclosures a platform must be used with shaft]
- *4. Handle mechanism (FHN-HS12)

PLEASE NOTE:

1. Various other switch accessories and circuit breaker accessories are available from disconnect manufacturers. The above information is subject to change without notice. Please contact Hubbell-Wiegmann or the disconnect manufacturer if there are further questions.
2. The "Space Occupied" tables (pages G50-G59) are based upon information supplied by disconnect manufacturers. Hubbell-Wiegmann does not assume responsibility for the accuracy of these dimensions.

* Items available from disconnect manufacturer as complete kits.

Eaton Cutler-Hammer

When using a Type C361 disconnect switch, order:

- *1. A disconnect switch with an operating mechanism
- *2. An operating handle (C361H1 or C361H3)

When using a Type C371 circuit breaker operating mechanism with a C-H circuit breaker, order:

- *1. A circuit breaker
- *2. An operating mechanism
- *3. An operating handle

When using a Type SM handle mechanism, order:

1. A or circuit breaker
2. A type SM handle mechanism

When using a Flex Shaft™ handle mechanism, order:

1. A circuit breaker
2. A complete Flex Shaft™ handle mechanism

General Electric

When using a disconnect switch, order:

1. A disconnect switch (Type QMR or QMW)
2. A fuse clip kit or no-fuse kit
3. A flange handle (STDA1 or STDA2)
4. A variable depth operating mechanism
5. An extended length drive rod

When using a circuit breaker, order:

1. A circuit breaker
2. A flange handle (STDA1 or STDA2)
3. A variable depth operating mechanism
4. An extended length drive rod

When using a circuit breaker with a Spectra Flex™ cable operator, order:

1. A circuit breaker
2. A flange-mounted handle mechanism
3. A breaker-mounted mechanism
4. An operating cable

Siemens ITE Max-Flex™

When using a disconnect switch, order:

1. A basic switch (right-hand)
2. A fuse or no-fuse kit
- *3. FHOHS flange-mounted handle
- *4. Switch operator
- *5. FHOECO48 cable

When using a circuit breaker, order:

1. A circuit breaker
2. Pressure wire connectors
- *3. A flange-mounted handle
- *4. A circuit breaker operator mechanism
- *5. An operating cable [18.12" (460mm) deep or 20.12" (511mm) deep enclosures accept 36.00" (914mm) or 48.00" (1219mm) cables; 24.12" (613mm) deep enclosures require a 48.00" (1219mm) cable]

* These items are available from Siemens ITE Max-Flex™ as a complete mechanism with a 36.00" (914mm) operating cable only. Order items separately when using a 48.00" (1219mm) operating cable.

Schneider Square D®

When using a disconnect switch, order:

1. A disconnect switch with operating mechanism
2. A universal handle mechanism
3. A long operating rod, if required

When using a circuit breaker, order:

1. A circuit breaker
2. An operating mechanism
3. A universal handle mechanism
4. A long operating rod, if required

When using a Class 9422 Type "T" disconnect switch with a cable mechanism, order:

1. A disconnect switch with operating mechanism (Class 9422 Type T)
2. A handle mechanism (Class 9422 Type A-1)
3. A cable mechanism (Class 9422 CFT_O) 3-, 5-, or 10-foot

When using a circuit breaker with a cable mechanism, order:

1. A circuit breaker (Schneider Square D®)
2. A handle mechanism (Class 9422 Type A-1)
3. A cable mechanism (Class 9422)

WAX-SSN4 & WACPX-SSN4 ENCLOSURES NEMA 4X TWO DOOR FLOOR-MOUNT DISCONNECT



WA7CPX312SSN4

Industry Standards

UL 508A, Type 4, 4X & 12

CSA Certified, Type 4, 4X & 12

NEMA/EEMAC Type 4, 4X & 12

 UL File E64791

 CSA File LL66078

FEATURES-SPECIFICATIONS

Applications

Enclosure having the "WM" preferred cutout are sized for use with up to 200A disconnect switches and up to 400A circuit breakers unless otherwise specified. The "WM" preferred cutout accepts the smaller operating handle whose mounting hole centers are 4.677 in. apart.



**"WM" PREFERRED
CUTOUT
for WAXSSN4 &
WACPXSSN4**

Allen-Bradley

- 1494V disconnect switches with flange-mount variable depth operating mechanisms and 1494V flange-mounted variable depth operating mechanisms for circuit breakers
- 140U flexible cable operating mechanisms and 140U molded case circuit breakers
- 1494C cable-operated disconnect switches with flange-mount handles
- 194RC cable-operated flange-mount handles for use with the NFPA 79 compliant 194R IEC rotary disconnect switches

Allen-Bradley 1494V-R1, -R2 and -W2 operating handles and Allen-Bradley 1494F disconnect devices or 1494D circuit breaker operators will NOT fit these enclosures.

- **ABB Controls** flange-mounted variable depth operating mechanisms for disconnect switches and circuit breakers. Also the cable version for circuit breakers.
- **Eaton Cutler-Hammer** Type C361 flange-mount variable depth operating mechanisms with disconnect switches and Type C371 flange-mount variable-depth operating mechanisms for circuit breakers.

- **General Electric** Type STDA flange handles and variable depth operating mechanisms for disconnect switches and circuit breakers. Also Spectra Flex™ cable operators for circuit breakers
- **Siemens ITE Max-Flex™** flange-mounted variable depth operating handles for circuit breakers
- **Schneider Square D®** Class 9422 disconnect switches with flange-mounted variable depth operating mechanisms or cable mechanisms and Class 9422 flange-mount variable-depth operating mechanism or cable mechanisms for circuit breakers.

These enclosures will not accept Schneider Square D® Class 9422 bracket-mounted disconnect devices, Class 9422TG1 or TG2 devices.

All 24.12 in. and deeper enclosures using short connecting rods by the following manufacturers

- **ABB Controls** flange-operated devices
- **Eaton Cutler-Hammer** C361 devices
- **Eaton Cutler-Hammer** C371 mechanisms which use C371E, F, G, K operating mechanism (see Disconnect Enclosure Accessories)
- **General Electric** Type TDA devices (see Disconnect enclosure Accessories)
- **Schneider Square D** Class 9422 devices (see Disconnect enclosure Accessories)

Require long connecting rods ordered in place of short connecting rods.

- For **Eaton Cutler-Hammer** operating mechanisms C371E and C371F order catalog number C371CS1 connecting rod. For C371G and C371K order catalog number C371CS2 connecting rod.

- For **General Electric** devices, order catalog number TDSR extended length drive rod
- For **Schneider Square D** devices, order catalog number 9422-R2 extra long operating rod(s). Some devices require two rods.

IMPORTANT Ordering Information

- Disconnect switch or circuit breakers, operating handle and operating mechanism are **not** furnished with the enclosure and must be ordered separately from the disconnect manufacturer
- Disconnect ordering information is located on page G49
- Review space occupied by disconnect drawings on page G45 and disconnect tables on pages G50-G59 to determine if the disconnect device you are using will fit the enclosure size you have selected

Construction

- Bodies and doors are fabricated from 304 stainless steel.
- Seams are continuously welded and ground smooth
- Body stiffeners provided for extra rigidity
- Heavy gauge continuous hinges to secure doors
- Heavy-duty 3-point 316L SS padlocking handles on all doors
- 15-inch floor stands are welded to enclosure
- Doors are sealed with a poured in place gasket
- Heavy-duty lifting eyes and provisions for lighting are provided
- Collar studs are provided for mounting **optional** back panels
- Grounding provisions are provided

- Unless specified, the right door is considered to be the “Master” door on the “Right Flange” disconnect enclosures and the left door is the “Master” door on the “Center Post” disconnect enclosures.
- A mechanical interlock is provided and prevents the slave door from opening before opening the master door

- Disconnects come with a “WM” cutout
 - Removable center post permits easy panel installation
- Finish**
- Exterior surfaces of the enclosure have a smooth grained finish
 - **Optional** back panels are painted with a white polyester powder

- **Optional** “G” panels are pre-galvanized steel

Accessories

- See pages L1-L24
- Blank adapter plates on page G60

WAX-SSN4 ENCLOSURES NEMA 4X TWO DOOR RIGHT FLANGE DISCONNECT

Catalog Number	Enclosure Size HxWxD	Back Panel Catalog Number*		Back Panel Size AxB
		White	“G”	
WA60X4912SSN4	60.12x49.75x12.12 (1527x1264x308)	NPDD6048	NPDD6048G	56.00x44.00 (1422x1118)
WA60X4918SSN4	60.12x49.75x18.12 (1527x1264x460)	NPDD6048	NPDD6048G	56.00x44.00 (1422x1118)
WA60X6112SSN4	60.12x61.75x12.12 (1527x1568x308)	NPDD6060	NPDD6060G	56.00x56.00 (1422x1422)
WA60X6118SSN4	60.12x61.75x18.12 (1527x1568x460)	NPDD6060	NPDD6060G	56.00x56.00 (1422x1422)
WA72X6112SSN4	72.12x61.75x12.12 (1832x1568x308)	NPDD7260	NPDD7260G	68.00x56.00 (1727x1422)
WA72X6118SSN4	72.12x61.75x18.12 (1832x1568x460)	NPDD7260	NPDD7260G	68.00x56.00 (1727x1422)
WA72X7312SSN4	72.12x73.75x12.12 (1832x1873x308)	NPDD7272	NPDD7272G	68.00x68.00 (1727x1727)
WA72X7318SSN4	72.12x73.75x18.12 (1832x1873x460)	NPDD7272	NPDD7272G	68.00x68.00 (1727x1727)
WA72X7324SSN4	72.12x73.75x24.12 (1832x1873x613)	NPDD7272	NPDD7272G	68.00x68.00 (1727x1727)

WACPX-SSN4 ENCLOSURES NEMA 4X TWO DOOR CENTER POST DISCONNECT

Catalog Number	Enclosure Size HxWxD	Back Panel Catalog Number*		Back Panel Size AxB
		White	“G”	
WA60CPX4812SSN4	60.12x48.50x12.12 (1527x1273x308)	NPDD6048	NPDD6048G	56.00x44.00 (1422x1118)
WA60CPX6012SSN4	60.12x60.50x12.12 (1527x1273x308)	NPDD6060	NPDD6060G	56.00x56.00 (1422x1422)
WA72CPX7212SSN4	72.12x72.50x12.12 (1832x1273x308)	NPDD7272	NPDD7272G	68.00x68.00 (1728x1728)
WA72CPX7218SSN4	72.12x72.50x18.12 (1832x1273x460)	NPDD7272	NPDD7272G	68.00x68.00 (1728x1728)

*Back panels must be ordered separately.

Note:

1. See pages G50-G59 for various brands of disconnects for “E”, “F”, “G”, “K” and “WB” dimensions.
2. Disconnects will occupy space on panel shown by dimensions “E”, “F”, “G” and “K”. Wiring space “WB” is available when disconnect is installed in the enclosure.
3. When ordering 24.13 (613mm) deep enclosures, long connecting rods must be ordered. Long connecting rods are available from disconnect manufacturers.
 - ABB Controls flange-operated devices
 - Eaton Cutler-Hammer C361 devices
 - Eaton Cutler-Hammer C371 operating mechanisms C371E and C371F, order catalog number C371CS1 connecting rod. For C371G and C371K, order catalog number C371CS2 connecting rod.
 - General Electric TDA devices, order catalog number TDSR extended length drive rod
 - For Schneider Square D® 9422 devices, order catalog number 9422-R2 extra long operating rod(s). Some devices require two rods.

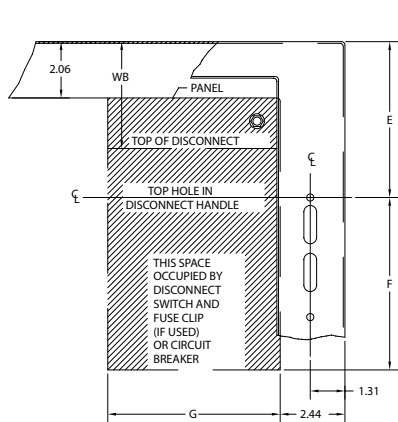

“WAX-SSN4” Style Enclosures

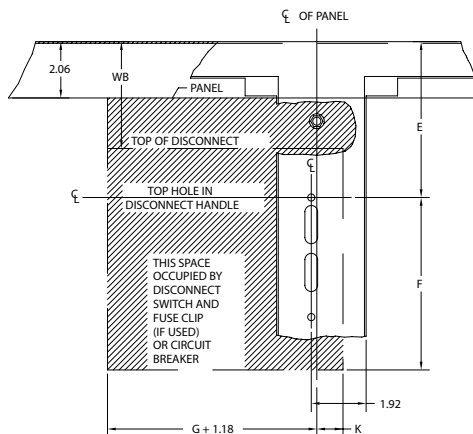

“WACPX-SSN4” Style Enclosures

Refer to *National Electrical Code®* article 430-10(b) for wiring space required for line side conductors to be connected to disconnect. Verify your application to determine if wiring space is adequate.

**WAX-SSN4 & WACPX-SSN4 ENCLOSURES
NEMA 4X TWO DOOR FLOOR-MOUNT DISCONNECT**

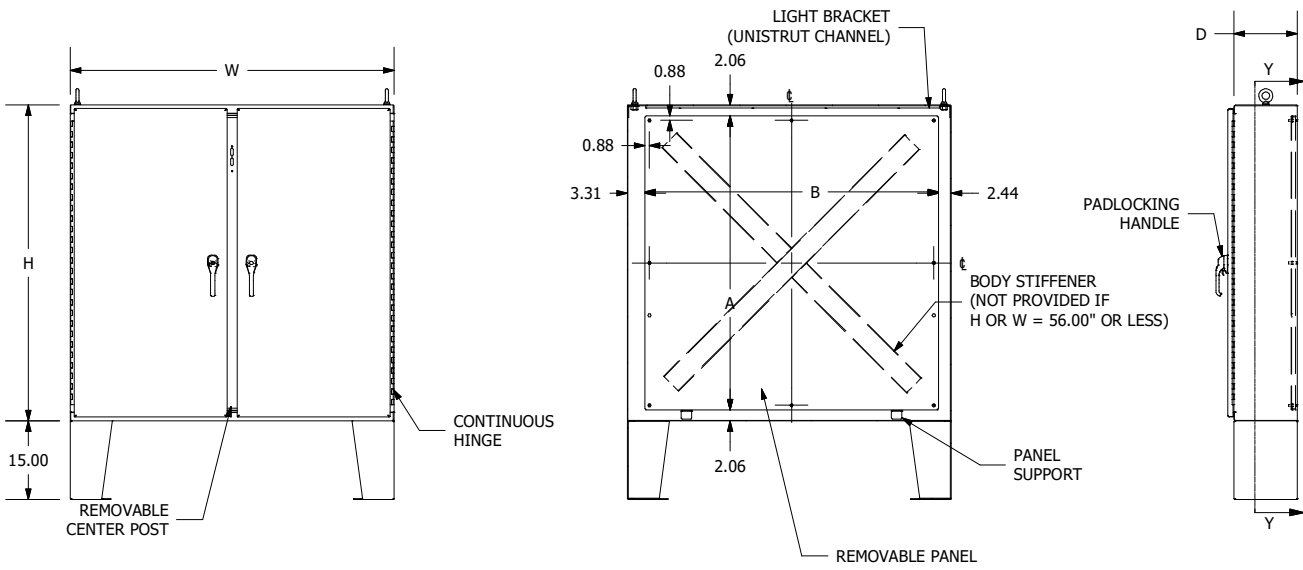
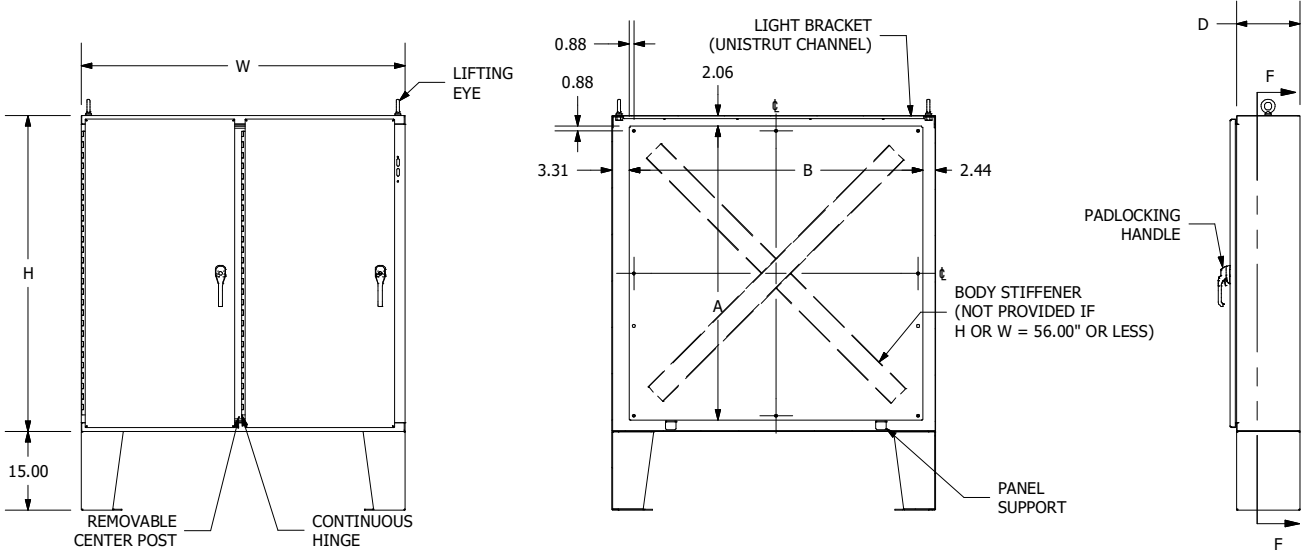



WA72XM2818SSN4

Industry Standards

UL 508A, Type 3R, 4, 4X & 12
CSA Certified, Type 4, 4X & 12
NEMA/EEMAC Type 3R, 4, 4X & 12

 UL File E64791

 CSA File LL66078

FEATURES-SPECIFICATIONS

Applications

Enclosure having the “WM” preferred cutout are sized for use with up to 200A disconnect switches and up to 400A circuit breakers unless otherwise specified. The “WM” preferred cutout accepts the smaller operating handle whose mounting hole centers are 4.677 in. apart. See Page G44 for Allen-Bradley, ABB, Eaton Cutler Hammer, General Electric, Siemens ITE & Schneider Square D options.



**“WM” PREFERRED CUTOUT
WAXM-SSN4**

- Heavy gauge continuous hinges to support each door
- Heavy-duty lifting eyes and provisions for lighting are provided
- 3-point 316L SS padlocking handles on all doors
- Center posts are removable to permit easy panel installation
- Grounding provisions are provided
- Doors are sealed with a poured in place gasket
- Unless specified, the far right door is considered to be the “Master” door. All other doors are considered slave doors.
- The mechanical interlock is activated by the master door which prevents the slave doors from being opened first. Doors can be closed in any order
- Disconnects come with a “WM” Preferred cutout which provides mounting for most disconnect operators by using operator adapters

IMPORTANT Ordering Information

- Disconnect switch, circuit breakers, operating handle and operating mechanism are **not** furnished with the enclosures and must be ordered separately from the disconnect manufacturer
- Disconnect ordering information is located on page G49
- Review space occupied by disconnect drawings on page G48 and disconnect tables on pages G50-G59 to determine if the disconnect device you are using will fit the enclosure size you have selected

Construction

- Bodies and doors are fabricated from 304 stainless steel.
- Removable back panels are included and mounted on collar studs
- Seams are continuously welded and ground smooth
- Body stiffeners provided for extra rigidity

Finish

- Exterior surfaces of the enclosure have a smooth grained finish
- Included back panels are painted with a white polyester powder

Accessories

- See pages L1-L24
- Back panels (reference table)

Space Occupied by Disconnect

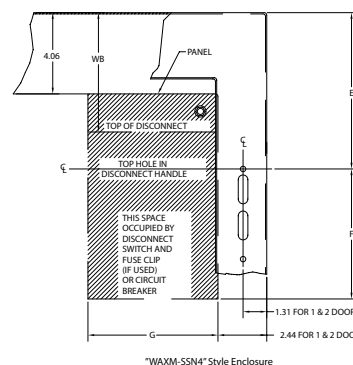

Note:

1. See pages G50-G59 for various brands of disconnects for “E”, “F”, “G” and “WB” dim.
2. Disconnects will occupy space on panel shown by dimensions “E”, “F” and “G”. Wiring space “WB” is available when disconnect is installed in the enclosure.
3. When ordering 24.13 (613mm) deep enclosures, long connecting rods must be ordered. Long connecting rods are available from disconnect manufacturers.
 - ABB Controls flange-operated devices
 - Eaton Cutler-Hammer C361 devices
 - Eaton Cutler-Hammer C371 operating mechanisms C371E and C371F, order catalog number C371CS1 connecting rod. For C371G and C371K, order catalog number C371CS2 connecting rod.
 - General Electric TDA devices, order catalog number TDSR extended length drive rod
 - For Schneider Square D® 9422 devices, order catalog number 9422-R2 extra long operating rod(s). Some devices require two rods.

Refer to National Electrical Code® article 430-10(b) for wiring space required for line side conductors to be connected to disconnect. Verify your application to determine if wiring space is adequate.

WAXM-SSN4 SERIES ENCLOSURES NEMA 4X RIGHT FLANGE SINGLE & DOUBLE DOOR FREESTANDING DISCONNECT

WAXM-SSN4 ENCLOSURES NEMA 4X SINGLE DOOR RIGHT FLANGE FREESTANDING DISCONNECT

Catalog Number	Size HxWxD	Back Panel Size AxB*
WA72XM2718SSN4	72.12x27.50x18.12 (1832x718x460)	60.00x21.75 (1524x552)
WA72XM3318SSN4	72.12x33.50x18.12 (1832x870x460)	60.00x27.75 (1524x705)
WA72XM3918SSN4	72.12x39.50x18.12 (1832x1022x460)	60.00x33.75 (1524x857)
WA84XM3918SSN4	84.12x39.50x18.12 (2137x1022x460)	72.00x33.75 (1829x857)
WA84XM3924SSN4	84.12x39.50x24.12 (2137x1022x613)	72.00x33.75 (1981x857)
WA90XM3918SSN4	90.12x39.50x18.12 (2289x1022x460)	78.00x33.75 (2007x857)
WA90XM3920SSN4	90.12x39.50x20.12 (2289x1022x511)	78.00x33.75 (2032x857)
WA90XM3924SSN4	90.12x39.50x24.12 (2289x1022x613)	78.00x33.75 (2057x857)

WA-XM-SSN4 ENCLOSURES NEMA 4X TWO DOOR RIGHT FLANGE FREESTANDING DISCONNECT

Catalog Number	Size HxWxD	Back Panel Size AxB*
WA72XM5318SSN4	72.12x54.50x18.12 (1832x1384x460)	60.00x48.00 (1524x1219)
WA72XM6518SSN4	72.12x66.50x18.12 (1832x1689x460)	60.00x60.00 (1524x1524)
WA72XM7718SSN4	72.12x78.50x18.12 (1832x1994x460)	60.00x72.00 (1524x1829)
WA72XM7724SSN4	72.12x78.50x24.12 (1832x1994x613)	60.00x72.00 (1524x1829)
WA84XM7718SSN4	84.12x78.50x18.12 (2137x1022x460)	72.00x72.00 (1829x1829)
WA84XM7724SSN4	84.12x78.50x24.12 (2137x1022x613)	72.00x72.00 (1829x1829)
WA90XM7718SSN4	90.12x78.50x18.12 (2289x1994x460)	78.00x72.00 (1981x1829)
WA90XM7720SSN4	90.12x78.50x20.12 (2289x1994x511)	78.00x72.00 (1981x1829)
WA90XM7724SSN4	90.12x78.50x24.12 (2289x1994x613)	78.00x72.00 (1981x1829)

*Back panels must be ordered separately.

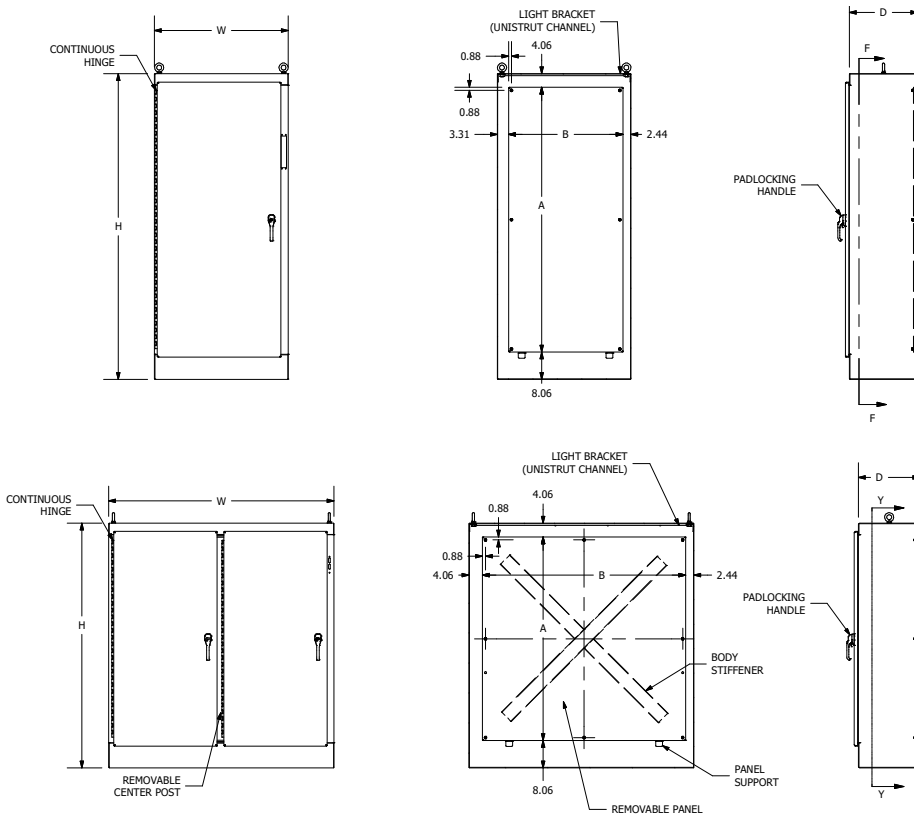

DISCONNECT ORDERING INFORMATION

When ordering wall-mounted disconnects from the various manufacturers, be sure to order all of the necessary items. Each company has a different system, so care is required. Order the following items from the disconnect manufacturer.

Allen-Bradley

When using a Bulletin 1494F flange-mounted disconnect switch, order:

1. A disconnect switch
2. A fuse block adapter, if required
3. Line and load connectors, if required

When using a Bulletin 1494D flange-mounted operator for a circuit breaker, order:

1. A circuit breaker
2. A flange-mounted operating mechanism
3. A slide mechanism

When using a Bulletin 1494V disconnect switch, order:

- *1. A disconnect switch
- *2. An operating handle
- *3. A connecting rod (long)
- *4. A trailer fuse block kit, if required
- *5. A fuse clip kit, if required
6. Line and load connectors, if required

When using a Bulletin 1494V circuit breaker operating mechanism, order:

1. A circuit breaker
2. A circuit breaker operating mechanism
3. An operating handle
4. A connecting rod (long)

ABB Controls

When using a disconnect switch, order:

1. A flange operated switch (fusible or non-fusible)
2. A shaft [DSFHS-17 for 18.12" (460mm) deep or DSFHS-22 for 20.12" (511mm) deep enclosures; in 24.12" (613mm) deep enclosures a platform must be used with shaft]
3. A handle (DSFHN-HS12)

When using a circuit breaker, order:

1. A circuit breaker (ABB)
- *2. An operating mechanism
- *3. A shaft [FHS-17 for 18.12" (460mm) deep or FHS-22 for 20.12" (511mm) deep enclosures; in 24.12" (613mm) deep enclosures a platform must be used with shaft]
- *4. Handle mechanism (FHN-HS12)

PLEASE NOTE:

1. Various other switch accessories and circuit breaker accessories are available from disconnect manufacturers. The above information is subject to change without notice. Please contact Hubbell-Wiegmann or the disconnect manufacturer if there are further questions.
2. The "Space Occupied" tables (pages G50-G59) are based upon information supplied by disconnect manufacturers. Hubbell-Wiegmann does not assume responsibility for the accuracy of these dimensions.

* Items available from disconnect manufacturer as complete kits.

Eaton Cutler-Hammer

When using a Type C361 disconnect switch, order:

- *1. A disconnect switch with an operating mechanism
- *2. An operating handle (C361H1 or C361H3)

When using a Type C371 circuit breaker operating mechanism with a C-H circuit breaker, order:

- *1. A circuit breaker
- *2. An operating mechanism
- *3. An operating handle

When using a Type SM handle mechanism, order:

1. A circuit breaker
2. A type SM handle mechanism

When using a Flex Shaft™ handle mechanism, order:

1. A circuit breaker
2. A complete Flex Shaft™ handle mechanism

General Electric

When using a disconnect switch, order:

1. A disconnect switch (Type QMR or QMW)
2. A fuse clip kit or no-fuse kit
3. A flange handle (STDA1 or STDA2)
4. A variable depth operating mechanism
5. An extended length drive rod

When using a circuit breaker, order:

1. A circuit breaker
2. A flange handle (STDA1 or STDA2)
3. A variable depth operating mechanism
4. An extended length drive rod

When using a circuit breaker with a Spectra Flex™ cable operator, order:

1. A circuit breaker
2. A flange-mounted handle mechanism
3. A breaker-mounted mechanism
4. An operating cable

Siemens ITE Max-Flex™

When using a disconnect switch, order:

1. A basic switch (right-hand)
2. A fuse or no-fuse kit
- ** 3. FHOHS flange-mounted handle
- ** 4. Switch operator
- ** 5. FHOECO48 cable

When using a circuit breaker, order:

1. A circuit breaker
2. Pressure wire connectors
- ** 3. A flange-mounted handle
- ** 4. A circuit breaker operator mechanism
- ** 5. An operating cable [18.12" (460mm) deep or 20.12" (511mm) deep enclosures accept 36.00" (914mm) or 48.00" (1219mm) cables; 24.12" (613mm) deep enclosures require a 48.00" (1219mm) cable]

** These items are available from Siemens ITE Max-Flex™ as a complete mechanism with a 36.00" (914mm) operating cable only. Order items separately when using a 48.00" (1219mm) operating cable.

Schneider Square D®

When using a disconnect switch, order:

1. A disconnect switch with operating mechanism
2. A universal handle mechanism
3. A long operating rod, if required

When using a circuit breaker, order:

1. A circuit breaker
2. An operating mechanism
3. A universal handle mechanism
4. A long operating rod, if required

When using a Class 9422 Type "T" disconnect switch with a cable mechanism, order:

1. A disconnect switch with operating mechanism (Class 9422 Type T)
2. A handle mechanism (Class 9422 Type A-1)
3. A cable mechanism (Class 9422 CFT_O) 3-, 5-, or 10-foot

When using a circuit breaker with a cable mechanism, order:

1. A circuit breaker (Schneider Square D®)
2. A handle mechanism (Class 9422 Type A-1)
3. A cable mechanism (Class 9422 CFT_O) 3-, 5-, or 10-foot

**FLOOR-MOUNT • FREESTANDING • MODULAR SERIES ENCLOSURES
DISCONNECT SPACE OCCUPIED & AVAILABLE WIRING SPACE INFORMATION**

ALLEN-BRADLEY TYPE 1494F DISCONNECT SWITCHES†

Type Number	Amp Rating	Fuse Clip	Fuse Class	Wire Bend Space "WB" Above Disconnect								
				Space Occupied			Two Door Floor-Mount (Pages G27-28 & G44-45)		Freestanding & Modular (Pages G31-G48)			
				F	G*	K	When H= 60.12 WB	When H= 72.12 WB	When H= 72.12 WB	When H= 84.12 WB	When H= 90.12 WB	
N30	30A	No fuse	—	4.62	6.5	0.99	5.31	11.31	9.31	15.31	18.31	
NF30	30A	30A-250V	H, K, R	6.5	6.5	0.99	5.31	11.31	9.31	15.31	18.31	
NF30	30A	60A-250V	H, K, R	7.25	6.5	0.99	5.31	11.31	9.31	15.31	18.31	
NF30	30A	30A-600V	H, K, R	9.25	6.5	0.99	5.31	11.31	9.31	15.31	18.31	
NF30	30A	60A-600V	H, K, R	9.75	6.5	0.99	5.31	11.31	9.31	15.31	18.31	
NF30	30A	30A-600V	J	6.5	6.5	0.99	5.31	11.31	9.31	15.31	18.31	
NF30	30A	60A-600V	J	6.62	6.5	0.99	5.31	11.31	9.31	15.31	18.31	
N60	60A	No fuse	—	4.62	6.5	0.99	4.62	10.62	8.62	14.62	17.62	
NF60	60A	30A-600V	H, K, R	10.38	6.5	0.99	4.62	10.62	8.62	14.62	17.62	
NF60	60A	60A-250V	H, K, R	8.38	6.5	0.99	4.62	10.62	8.62	14.62	17.62	
NF60	60A	100A-250V	H, K, R	10.88	6.5	0.99	4.62	10.62	8.62	14.62	17.62	
NF60	60A	60A-600V	H, K, R	10.88	6.5	0.99	4.62	10.62	8.62	14.62	17.62	
NF60	60A	100A-600V	H, K, R	12.88	6.62	0.99	4.62	10.62	8.62	14.62	17.62	
NF60	60A	60A-600V	J	7.75	6.5	0.99	4.62	10.62	8.62	14.62	17.62	
NF60	60A	100A-600V	J	9.75	6.5	0.99	4.62	10.62	8.62	14.62	17.62	
N100	100A	No fuse	—	4.62	7.25	0.99	—	8.75	6.75	12.75	15.75	
NF100	100A	100A-250V	H, K, R	11.38	7.38	0.99	—	8.75	6.75	12.75	15.75	
NF100	100A	200A-250V	H, K, R	12.25	7.62	0.99	—	8.75	6.75	12.75	15.75	
NF100	100A	100A-600V	H, K, R	13.38	7.5	0.99	—	8.75	6.75	12.75	15.75	
NF100	100A	200A-600V	H, K, R	14.75	7.75	0.99	—	8.75	6.75	12.75	15.75	
NF100	100A	100A-600V	J	10.12	7.38	0.99	—	8.75	6.75	12.75	15.75	
NF100	100A	200A-600V	J	10.88	7.5	0.99	—	8.75	6.75	12.75	15.75	
N200	200A	No fuse	—	7.12	10.38	1.06	—	7.12	5.12	11.12	14.12	
NF200	200A	200A-250V	H, K, R	15	10.38	1.06	—	7.12	5.12	11.12	14.12	
NF200	200A	400A-250V	H, K, R	16.56	10.75	1.06	—	7.12	5.12	11.12	14.12	
NF200	200A	200A-600V	H, K, R	17.56	10.38	1.06	—	7.12	5.12	11.12	14.12	
NF200	200A	400A-600V	H, K, R	19.56	11	1.06	—	7.12	5.12	11.12	14.12	
NF200	200A	200A-600V	J	13.69	10.38	1.06	—	7.12	5.12	11.12	14.12	
NF200	200A	400A-600V	J	15	10.62	1.06	—	7.12	5.12	11.12	14.12	

ALLEN-BRADLEY TYPE 1494D OPERATORS FOR CIRCUIT BREAKERS†

Type Number	Amp Rating	Circuit Breaker Type Frame Size	Wire Bend Space "WB" Above Disconnect								
			Space Occupied			Two Door Floor-Mount (Pages G27-28 & G44-45)		Freestanding & Modular (Pages G31-G48)			
			F	G*	K	When H= 60.12 WB	When H= 72.12 WB	When H= 72.12 WB	When H= 84.12 WB	When H= 90.12 WB	
N4/N40	150A	EHD, FD, FDB, FDC, HFD, HMCP General Electric	5.81	4.56	0.99	5.25	11.25	9.25	15.25	18.15	
N5/N55	225A	TFK, THFK, TFC	8.81	4.75	0.99	4.44	10.44	8.44	14.44	17.44	
N5/N50	250A	JD, JDB, JDC, HJD, HMCP	8.81	4.75	0.99	4.44	10.44	8.44	14.44	17.44	
N5/N60	400A	KD, KDB, KDC, HKD, HMCP	8.81	5.88	0.99	—	10.5	8.5	14.5	17.5	

*The "G" dimension does not include space for auxiliary switches. See Allen-Bradley instructions for additional space required.

†For Two Door Floor-Mount NEMA 12 (Pages G27-G28 & G44-G45)

"E" = 5.88 when "H" = 60.12

"E" = 11.38 when "H" = 72.12, except 200A switches

"E" = 10.06 when "H" = 72.12, 200A switches only

For Heavy Duty Freestanding and Modular Enclosures (Pages G31 - G48)

"E" = 9.88 when "H" = 72.12, except 200A switch "E" = 8.56 when "H" = 72.12, 200A switch

"E" = 15.38 when "H" = 84.12, except 200A switch "E" = 14.06 when "H" = 84.12, 200A switch

"E" = 18.38 when "H" = 90.12, except 200A switch "E" = 17.06 when "H" = 90.12, 200A switch

**FLOOR-MOUNT • FREESTANDING • MODULAR SERIES ENCLOSURES
DISCONNECT SPACE OCCUPIED & AVAILABLE WIRING SPACE INFORMATION**

ALLEN-BRADLEY TYPE 1494V OPERATORS FOR CIRCUIT BREAKERS†

Type Number	Amp Rating	Circuit Breaker Type Frame Size	Wire Bend Space "WB" Above Disconnect							
			Space Occupied			Two Door Floor-Mount (Pages G27-28 & G44-45)		Freestanding & Modular (Pages G31-G48)		
			F	G*	K	When H= 60.12 WB	When H= 72.12 WB	When H= 72.12 WB	When H= 84.12 WB	When H= 90.12 WB
M40	15A-150A	EHD, FD, FDB, FDC, HFD, HMCP	5	4.62	0.56	7.25	13.25	11.25	17.25	20.25
M50	70A-250A	JD, JDB, JDC, HJD, HMCP	9.75	4.88	0.56	6.81	12.81	10.81	16.81	19.81
M60	100A-400A	KD, KDB, KDC, HKD, HMCP	9.69	6.25	0.56	—	12.62	10.62	16.62	19.62

*The "G" dimension does not include space for auxiliary switches. See Allen-Bradley instructions for additional space required.

†For Two Door Floor-Mount NEMA 12 "E" = 7.88 when "H" = 60.12
(Pages G27-G28 & G44-G456) "E" = 13.38 when "H" = 72.12

For Heavy Duty Freestanding and Modular Enclosures (Pages G31 - G48) "E" = 11.88 when "H" = 72.12
"E" = 17.38 when "H" = 84.12, except 400A or 600A switches
"E" = 20.38 when "H" = 90.12, except 400A or 600A switches
"E" = 15.93 when "H" = 84.12, 400A and 600A switches only
"E" = 18.93 when "H" = 90.12, 400A and 600A switches only

ABB CONTROLS DISCONNECT SWITCHES WITH FLANGE-MOUNTED OPERATORS†

Type Number	Amp Rating	Fuse Clip	Fuse Class	Wire Bend Space "WB" Above Disconnect							
				Space Occupied			Two Door Floor-Mount (Pages G27-28 & G44-45)		Freestanding & Modular (Pages G31-G48)		
				F	G	K	When H= 60.12 WB	When H= 72.12 WB	When H= 72.12 WB	When H= 84.12 WB	When H= 90.12 WB
OETL-NF30-F	40A	No fuse	—	4.45	3.91	0.56	9.53	15.53	13.53	19.53	22.53
OETL-NF60-F	80A	No fuse	—	4.86	3.91	0.56	9.34	15.34	13.34	19.34	22.34
OETL-NF100-F	100A	No fuse	—	4.86	4.91	0.56	8.78	14.78	12.78	18.78	21.78
OETL-NF175-F	175A	No fuse	—	7.3	6.62	0.56	6.53	12.53	10.53	16.53	19.53
OETL-NF200-F	200A	No fuse	—	7.36	7.41	0.56	6.53	12.53	10.53	16.53	19.53
OESA-F30J6-F	30A	30A-600V	J	4.28	6.7	0.56	7.85	13.85	11.86	17.86	20.86
OESA-F60J6-F	60A	60A-600V	J	4.28	6.39	0.56	7.85	13.85	11.86	17.86	20.86
OESA-F100J6-F	100A	100A-600V	J	6.54	7.78	0.56	7.42	13.42	11.42	17.42	20.42

ABB CONTROLS CIRCUIT BREAKERS WITH FLANGE-MOUNTED OPERATORS†

Type Number	Amp Rating	Frame Type	Wire Bend Space "WB" Above Disconnect							
			Space Occupied			Two Door Floor-Mount (Pages G27-28 & G44-45)		Freestanding & Modular (Pages G31-G48)		
			F	G	K	When H= 60.12 WB	When H= 72.12 WB	When H= 72.12 WB	When H= 84.12 WB	When H= 90.12 WB
FHD-M	150A	D	6.92	4.06	0.56	8.42	13.92	12.42	17.92	20.92
FHF-M	150A, 225A	E/Q	5.98	4.55	0.56	6.97	12.47	10.97	16.47	19.47
FHF-M	225A	F	7.44	4.55	0.56	6.97	12.47	10.97	16.47	19.47
FHJ-M	400A	J	9.71	5.75	0.56	5.02	10.52	9.02	14.52	17.52
FHM-M	600A	L	8.28	11.39	0.56	—	10.03	8.53	14.03	17.03
FHM-M	800A	M	10.11	11.39	0.56	—	9.62	8.12	13.62	16.62
FHN-M	1200A	N	12.18	11.39	0.56	—	—	—	9.81	12.81

†For Two Door Floor-Mount NEMA 12 (Pages G27-G28 & G44-G45) "E" = 7.88 when "H" = 60.12
"E" = 13.38 when "H" = 72.12
For Heavy Duty Freestanding and Modular Enclosures (Pages G31- G48) "E" = 11.88 when "H" = 72.12
"E" = 17.38 when "H" = 84.12
"E" = 20.38 when "H" = 90.12

FLOOR-MOUNT • FREESTANDING • MODULAR SERIES ENCLOSURES DISCONNECT SPACE OCCUPIED & AVAILABLE WIRING SPACE INFORMATION

EATON CUTLER-HAMMER C361 DISCONNECT SWITCHES†

Type Number	Amp Rating	Fuse Clip	Fuse Class	Wire Bend Space "WB" Above Disconnect							
				Space Occupied			Two Door Floor-Mount (Pages G27-28 & G44-45)		Freestanding & Modular (Pages G31-G48)		
				F	G	K	When H= 60.12 WB	When H= 72.12 WB	When H= 72.12 WB	When H= 84.12 WB	When H= 90.12 WB
C361NC	30A	No fuse	—	5.75	7.55	0.56	6.5	12.5	10.5	16.5	19.5
C361SC21	30A	30A-250V	H, K, R	8.38	7.55	0.56	6.5	12.5	10.5	16.5	19.5
C361SC61	30A	60A-250V	H, K, R	8.38	7.55	0.56	6.5	12.5	10.5	16.5	19.5
C361SC61	30A	30A-600V	H, J, K, R	8.38	7.55	0.56	6.5	12.5	10.5	16.5	19.5
C361ND	60A	No fuse	—	5.75	7.55	0.56	6.5	12.5	10.5	16.5	19.5
C361SD22	60A	60A-250V	H, K, R	8.38	7.55	0.56	6.5	12.5	10.5	16.5	19.5
C361SD22	60A	30A-600V	J	8.38	7.55	0.56	6.5	12.5	10.5	16.5	19.5
C361SD62	60A	60A-600V	H, K, R	8.38	7.55	0.56	6.5	12.5	10.5	16.5	19.5
C361SD62	60A	60A-600V	J	8.38	7.55	0.56	6.5	12.5	10.5	16.5	19.5
C361NE	100A	No fuse	—	5.56	9.07	0.56	6.06	12.06	10.06	16.06	19.06
C361SE263	100A	100A-250V	H, K, R	10.31	9.07	0.56	6.06	12.06	10.06	16.06	19.06
C361SE263	100A	100A-250V	H, K, R	10.31	9.07	0.56	6.06	12.06	10.06	16.06	19.06
C361SE263	100A	100A-600V	J	10.31	9.07	0.56	6.06	12.06	10.06	16.06	19.06
C361NF	200A	No fuse	—	13.06	10.12	0.56	4.06	10.06	8.06	14.06	17.06
C361SF264	200A	200A-250V	H, K, R	13.06	10.12	0.56	4.06	10.06	8.06	14.06	17.06
C361SF264	200A	200A-600V	H, K, R	13.06	10.12	0.56	4.06	10.06	8.06	14.06	17.06

EATON CUTLER-HAMMER C371 CIRCUIT BREAKER OPERATORS‡

Type Number	Amp Rating	Frame Type	Wire Bend Space "WB" Above Disconnect							
			Space Occupied			Two Door Floor-Mount (Pages G27-28 & G44-45)		Freestanding & Modular (Pages G31-G48)		
			F	G	K	When H= 60.12 WB	When H= 72.12 WB	When H= 72.12 WB	When H= 84.12 WB	When H= 90.12 WB
C371E	225A	F Frame: EHD, FDB, FD, HFD, FDC	6	5.62	0.56	7.62	13.62	11.62	17.12	20.12
C371E	150A	F Frame: HMCP	6	5.62	0.56	7.62	13.62	11.62	17.12	20.12
C371F	225A	J Frame: JDB, JD, HJD, JDC	8.94	8.12	0.56	7.50*	13	11.44	16.94	20
C371F	225A	J Frame: HMCP	10.94	8.12	0.56	7.50*	13	11.44	16.94	20
C371F	400A	K Frame: DK, KDB, KD, HKD	9.75	8.12	0.56	7.00*	13	11	17	20
C371F	400A	K Frame: HMCP	9.75	8.12	0.56	7.00*	13	11	17	20
C371G	600A	L Frame: LD, HLD, LDC	8.44	12	0.56	—	10.88**	9.38	15.38	18.38
C371G	600A	L Frame: HMCP	8.44	12	0.56	—	10.88**	9.38	15.38	18.38
C371K	800A	M Frame: MD, MDS	10.25	12	0.56	—	—	—	11.81	14.81
C371K	1200A	N Frame: ND, HND, NDC	10.25	12	0.56	—	—	—	11.81***	14.81

* Available wire bend space "WB" does not allow cable sizes larger than 4/0 AWG in a 60.12-inch tall enclosure.

** Available wire bend space "WB" does not allow cable sizes larger than 300 MCM.

*** Available wire bend space "WB" does not allow cable sizes larger than 350 MCM in a 90.12-inch tall enclosure when using 4 cable per terminal.

See National Electrical Code®, table 373-6(b) for more information. Available wire bend space "WB" is insufficient for use with breakers equipped with TA1201NB1 terminals.

†For Two Door Floor-Mount NEMA 12
(Pages G27-G28 & G44-G45)

"E" = 7.88 when "H" = 60.12
"E" = 13.38 when "H" = 72.12

For Heavy-Duty Freestanding
and Modular Enclosures
(Pages G31- G48)

"E" = 11.88 when "H" = 72.12
"E" = 17.38 when "H" = 84.12
"E" = 20.38 when "H" = 90.12

**FLOOR-MOUNT • FREESTANDING • MODULAR SERIES ENCLOSURES
DISCONNECT SPACE OCCUPIED & AVAILABLE WIRING SPACE INFORMATION**

EATON CUTLER-HAMMER FLEX SHAFT™ OPERATOR MECHANISMS

Complete Operator Mechanism	Amp Rating	Frame Type	Breaker Type	Breaker width
F1S03	225A	F Frame: EHD, FDB, FD, HFD	6	4.12
F1S03	150A	F Frame: HMCP	6	4.12
F2S03	250A	J Frame: jdb, jd, hjd, jdc	10	4.12
F2S03	250A	J Frame: HMCP	10	4.12
F3S03	400A	K Frame: dk, kdb, kd, hkd	10.12	5.5
F3S03	400A	K Frame: HMCP	12.45	5.5
F4S04	600A	L Frame: LD, HLD, LDC	10.75	8.25
F4S04	600A	L Frame: HMCP	12.5	8.25
F7S04	800A	M Frame: MD, MDS	16	8.25
F5S04	1200A	N Frame: ND, HND, NDC	16	8.25
F6S04	2500A	R Frame: RD, CRD, RDC	16	15.5

- Catalog numbers for complete mechanisms include a flange-mounted handle, flexible shaft and circuit breaker mechanism.
- The last digit of the catalog number denotes the length of shaft (F1S03 = 3-foot shaft). The F, J, K frame Flex Shafts™ are available in 3-foot to 10-foot lengths. The L, N, R frame Flex Shafts are available in 4-foot to 6-foot lengths.

Space Occupied by Disconnect

- The Flex Shaft™ system allows the circuit breaker to be positioned independent from the flange-mounted handle mechanism.
- Refer to **National Electrical Code®** article 430-10(b) for wiring space "WB" required for line side conductors.
- Choose the length of shaft based on placement of the circuit breaker in the enclosure ensuring a 4-inch min. bending radius for the Flex Shaft.™
- Space occupied by circuit breaker is determined by overall height "X", width "Y", wire bend space "WB" and location "G" as selected from right to left.

EATON CUTLER-HAMMER C371 CIRCUIT BREAKER OPERATORS†

Handle Mechanism	Use With Circuit Breaker	Wire Bend Space "WB" Above Disconnect							
		Space Occupied			Two Door Floor-Mount (Pages G27-28 & G44-45)		Freestanding & Modular (Pages G31-G48)		
		F	G	K	When H= 60.12 WB	When H= 72.12 WB	When H= 72.12 WB	When H= 84.12 WB	When H= 90.12 WB
SM101PR	FB Tri-Pac	8	5.38	0.81	6.5	12.5	10.5	16.5	19.5
SM150R	F Frame: EHD, FDB, FD, HFD, FDC	8	5.38	0.81	6.5	12.5	10.5	16.5	19.5
SM250JR	J Frame: JDB, JD, HJD, JDC	8.5	7.5	0.81	—	10	8	14	17
SM400KR	K Frame: DK, KDB, KD, HKD	9.06	7.5	0.81	—	9.62	7.62	13.62	16.62
SM400PR	LA Tri-Pac	14.44	9.75	0.81	—	9.75	7.75	13.75	16.75
SM600R	L Frame: LD, HLD, LDC	8.81	7.62	0.81	—	—	—	12.88	15.88
SM800R	M Frame: MD, MDS, HMD	10.68	9.75	0.81	—	—	—	10.16	13.16
SM800PR	NB Tri-Pac	16.81	9.75	0.81	—	—	—	10.16	13.16

† For Two Door Floor-Mount NEMA 12 (Pages G27-G28 & G44-G45)
 "E" = 7.31 when "H" = 60.12 for up to type SM200
 "E" = 12.81 when "H" = 72.12 for up to type SM200
 "E" = 6.88 when "H" = 60.12 for type SM200 and larger
 "E" = 12.38 when "H" = 72.12 for type SM200 and larger

For Heavy-Duty Freestanding and Modular Enclosures (Pages G31 - G48)
 "E" = 11.31 when "H" = 72.12 for up to type SM200
 "E" = 16.81 when "H" = 84.12 for up to type SM200
 "E" = 19.81 when "H" = 90.12 for up to type SM200
 "E" = 10.88 when "H" = 72.12 for type SM200 and larger
 "E" = 16.38 when "H" = 84.12 for type SM200 and larger
 "E" = 19.38 when "H" = 90.12 for type SM200 and larger

FLOOR-MOUNT • FREESTANDING • MODULAR SERIES ENCLOSURES DISCONNECT SPACE OCCUPIED & AVAILABLE WIRING SPACE INFORMATION

GENERAL ELECTRIC TYPE STD A DISCONNECT SWITCH OPERATORS†

Switch Mechanism	Amp Rating	Fuse Clip	Fuse Class	Wire Bend Space "WB" Above Disconnect							
				Space Occupied			Two Door Floor-Mount (Pages G27-28 & G44-45)		Freestanding & Modular (Pages G31-G48)		
				F	G	K	When H= 60.12 WB	When H= 72.12 WB	When H= 72.12 WB	When H= 84.12 WB	When H= 90.12 WB
TDOM1A	30A	No fuse	—	6.88	5.38	0.56	8.38	14.38	12.38	18.38	21.38
TDOM1A	30A	30A-250V	H, R	6.88	5.38	0.56	8.38	14.38	12.38	18.38	21.38
TDOM1B	30A	30A-600V	H, R	11.5	5.38	0.56	8.38	14.38	12.38	18.38	21.38
TDOM1B	30A	60A-250V	H, R	11.5	5.38	0.56	8.38	14.38	12.38	18.38	21.38
TDOM1B	30A	60A-600V	H, R	11.5	5.38	0.56	8.38	14.38	12.38	18.38	21.38
TDOM1A	60A	No fuse	—	6.88	5.38	0.56	8.38	14.38	12.38	18.38	21.38
TDOM1B	60A	60A-250V	H, R	11.5	5.38	0.56	8.38	14.38	12.38	18.38	21.38
TDOM1B	60A	60A-600V	H, R	11.5	5.38	0.56	8.38	14.38	12.38	18.38	21.38
TDOM1B	60A	100A-250V	H, R	11.5	5.38	0.56	8.38	14.38	12.38	18.38	21.38
TDOM1B	60A	100A-600V	H, R	11.5	5.38	0.56	8.38	14.38	12.38	18.38	21.38
TDOM1A	100A	No fuse	—	6.88	5.38	0.56	8.38	14.38	12.38	18.38	21.38
TDOM1B	100A	100A-250V	H, R	11.5	5.38	0.56	8.38	14.38	12.38	18.38	21.38
TDOM1B	100A	100A-600V	H, R	11.5	5.38	0.56	8.38	14.38	12.38	18.38	21.38
TDOM1B	100A	200A-250V	H, R	11.5	5.38	0.56	8.38	14.38	12.38	18.38	21.38
TDOM1B	100A	200A-600V	H, R	11.5	5.38	0.56	8.38	14.38	9.69	18.38	21.38
TDOM2	200A	No fuse	—	7	9.25	0.56	5.69	11.69	9.69	15.69	18.69
TDOM2	200A	200A-250V	H, R	15.38	9.25	0.56	5.69	11.69	9.69	15.69	18.69
TDOM2	200A	200A-600V	H, R	15.38	9.25	0.56	5.69	11.69	9.69	15.69	18.69

GENERAL ELECTRIC TYPE STD A CIRCUIT BREAKERS OPERATORS†

Circuit Breaker Mechanism	Amp Rating	Frame Type	Wire Bend Space "WB" Above Disconnect							
			Space Occupied			Two Door Floor-Mount (Pages G27-28 & G44-45)		Freestanding & Modular (Pages G31-G48)		
			F	G	K	When H= 60.12 WB	When H= 72.12 WB	When H= 72.12 WB	When H= 84.12 WB	When H= 90.12 WB
SDOM1A	150A	TEB, TED, THED	6.88	5.38	0.56	7.24	13.24	11.24	17.24	20.24
SDOM1A	150A	TEC	6.88	5.38	0.56	7.24	13.24	11.24	17.24	20.24
TDOM1B	150A	TBI	11.5	5.38	0.56	7.24	13.24	11.24	17.24	20.24
TDOM1B	150A	TEC, TECL	11.5	5.38	0.56	7.24	13.24	11.24	17.24	20.24
TDOM1C	150A	TEL	6.88	5.38	0.56	7.24	13.24	11.24	17.24	20.24
TDOM1D	150A	THLCI	6.88	5.38	0.56	5.87	11.87	9.87	15.87	18.87
TDOM3	225A	TFJ	10.38	5.88	0.56	6.81	12.81	10.81	16.31	19.81
TDOM3	225A	TFK, THFK, TFL	10.38	5.88	0.56	6.81	12.81	10.81	16.31	19.81
TDOM4	400A	TJJ, TJK4, THJK4, TJL4V	8.25	9.5	0.56	—	11.91	9.91	15.91	18.91
TDOM4	600A	TJK6, THJK6, TJ4V, TJL4V	8.25	9.5	0.56	—	11.91	9.91	15.91	18.91
TDOM5	400A	TB4, TJH6S	14.25	9.5	0.56	—	11.91	9.91	15.91	18.91
TDOM6	225A	TLB2, THLC2	11.75	9.5	0.56	—	11.35	—	15.35	18.35
TDOM6	400A	TLB4, THLC4	11.75	9.5	0.56	—	9.97	—	13.97	16.97
TDOM6	800A-1200A	TKMA, THKMA, TK4V	11.75	9.5	0.56	—	—	—	—	18.38
TDOM6	1200A	TK4V, THK4V	11.75	9.5	0.56	—	—	—	—	18.38
TDOM7	600A	TB6	18.12	9.5	0.56	—	—	—	12.25	15.25
TDOM7	800A	TB8	18.12	9.5	0.56	—	—	—	12.25	15.25
TDOM7	1200A	TKLI2S	18.12	9.5	0.56	—	—	—	—	15.25
SDOM1A	150A	SPECTRA SE150	6.88	5.38	0.56	7.24	12.74	11.24	16.74	19.74
SDOM3	250A	SPECTRA SF250	10.38	5.88	0.56	6.81	11.38	10.81	16.31	19.31
SDOM4	600A	SPECTRA SG600	10	7.12	0.56	—	8.68	—	12.68	15.68

†For Two Door Floor-Mount NEMA 12
(Pages G27-G28 & G44-G45)

"E" = 7.88 when "H" = 60.12
"E" = 13.38 when "H" = 72.12

For Heavy-Duty Freestanding
and Modular Enclosures
(Pages G31 - G48)

"E" = 11.88 when "H" = 72.12
"E" = 17.38 when "H" = 84.12
"E" = 20.38 when "H" = 90.12

FLOOR-MOUNT • FREESTANDING • MODULAR SERIES ENCLOSURES DISCONNECT SPACE OCCUPIED & AVAILABLE WIRING SPACE INFORMATION

GENERAL ELECTRIC CIRCUIT BREAKERS WITH SPECTRA-FLEX™ CABLE OPERATORS†

Frame Size	Maximum Amp Rating	Circuit Breaker Height X	Circuit Breaker Width Y	Two Door Floor-Mount	Freestanding & Modular
E150	150A	6.31	4.12	For enclosures that accept these devices, (See pages G27-G28 & G44-G45)	For enclosures that accept these devices, (See pages G31-G48)
SE150	150A	6.31	4.12		
SF250	250A	10.12	4.12		
SG600	600A	10.09	5.5		

Frame Size	Breaker Mechanism	Flange Mounting Handle	Operating Cable*
E150	SCOM1A	SCH1	SC3L
SE150/SF250	SCOM1EF	SCH1	SC3L
SG600	SCOM1G	SCH1	SC3L
SK1200	SCOM1K	SCH2K	SC3H

*Operating cables are available in 3-foot to 10-foot lengths. (The number 3 in the catalog number denotes 3-foot cable.)

Space Occupied by Circuit Breaker

- The General Electric Spectra-Flex™ system allows the circuit breaker to be positioned independent from the flange-mounted handle mechanism.
- Refer to **National Electrical Code®** article 430-10(b) for wiring space "WB" required for line side conductors.
- Choose the length based on placement of the circuit breaker in the enclosure ensuring a 3-inch minimum bending radius for the cable.
- Space occupied by circuit breaker is determined by overall height "X", width "Y", wire bend space "WB" and location "G" as selected from right to left.

†For Two Door Floor-Mount NEMA 12 (Pages G27-G28 & G44-G45) "E" = 7.88 when "H" = 60.12
"E" = 13.38 when "H" = 72.12

For Heavy-Duty Freestanding and Modular Enclosures (Pages G31 & G48) "E" = 11.88 when "H" = 72.12
"E" = 17.38 when "H" = 84.12
"E" = 20.38 when "H" = 90.12

FLOOR-MOUNT • FREESTANDING • MODULAR SERIES ENCLOSURES DISCONNECT SPACE OCCUPIED & AVAILABLE WIRING SPACE INFORMATION

SIEMENS ITE MAX-FLEX™ DISCONNECT SWITCHES FOR MAX-FLEX™ OPERATORS†

Switch	Amp Rating	Fuse Clip	Fuse Class	Disconnect Height X	Disconnect Width Y	Two Door Floor-Mount	Freestanding & Modular
MCS603R	30A	No fuse	—	5.52	6.13		
MCS603R	30A	30A-250V	H, K, R	8.11	6.13		
MCS603R	30A	30A-600V	H, K, R	10.11	6.13		
MCS603R	30A	30A-600V	J	8.48	6.13		
MCS606R	60A	No fuse	—	5.52	6.13		
MCS606R	60A	60A-250V	H, K, R	7.86	6.13		
MCS606R	60A	60A-600V	H, K, R	10.38	6.13		
MCS606R	60A	60A-600V	J	8.36	6.13		
MCS610R	100A	No fuse	—	7.59	7.38		
MCS610R	100A	100A-250V	H, K, R	11.85	7.38		
MCS610R	100A	100A-600V	H, K, R	13.85	7.38		
MCS610R	100A	100A-600V	J	10.6	7.38		
MCS620R	200A	No fuse	—	9	9.17		
MCS620R	200A	200A-250V	H, K, R	14.7	9.17		
MCS620R	200A	200A-600V	H, K, R	17.2	9.17		
MCS620R	200A	200A-600V	J	13.32	9.17		

For enclosures that accept these devices, (See pages G27-G28 & G44-G45) For enclosures that accept these devices, (See pages G31-G48)

2 Door Floor-Mount NEMA 12, Heavy Duty Freestanding and Modular Enclosures, that are 24.00-inches deep, require a 48-inch Max-Flex™ cable (minimum cable length).

SIEMENS ITE MAX-FLEX™ CIRCUIT BREAKERS FOR MAX-FLEX™ OPERATORS†

Complete Operator Mechanism	Circuit Frame Size	Maximum Amp Rating	Circuit Breaker Height X	Circuit Breaker Height Y	Circuit Breaker Type
FHOE036	ED	125A	6.34	3	ED2, ED4, ED6, HED4, HED6
FHOE036	CED	125A	9.58	3	CED6
FHOF036	FD	250A	9.5	4.5	FXD6-A, FD6-A, HFD6, FXD6-ETJ, HHFD6, HHFXD6
FHOF036	CFD	250A	14.25	4.5	CFD6, CFD6-ETI
FHOJ036	JD	400A	11	7.5	JXD2, LXD6, JD6, HJD6, HHJD6, HHJXD6, JXD6-ETI
FHOJ036	CJD	400A	17.86	7.5	CJD6, CJD6-ETI
FHOJ036	LD	600A	11	7.5	LXD6, LD6, HLD6, HHL6, HHLXD6, LXD6-ETI
FHOJ036	CLD	600A	17.86	7.5	CLD6, CLD6-ETI
FHOLM036	LMD	800A	16	9	LMD6, LMXD6, HLM6, HLMXD6, LMXD6-ETI
FHON048	MD	800A	24	9	MD6, MXD6, HMD6, HMXD6, CMD6, MXD6-ETI, CMD6-ETI
FHON048	ND	1200A	24	9	ND6, NXD6, HND6, HNXD6, CND6
FHON048*	PD	1600A	24.5	13.63	PD6, PXD6, HPD6, HPXD6, CPD6
FHON048*	RD	2000A	24.5	13.63	RD6, RXD6, HRD6, HRXD6

Mechanisms and circuit breakers listed above will fit any 2 Door Floor-Mount NEMA 12, Heavy-Duty Freestanding and Modular Enclosure.

Catalog numbers are for complete mechanisms which include flange-mounted handle, flexible operating cable, and circuit breaker operator. The last 3 digits indicate cable length in inches.

24" deep enclosures require longer operating cables. Order components separately.

*Circuit breakers size includes required base mounting block.

Space Occupied by Circuit Breaker

- The Siemens ITE Max-Flex™ cable system allows the disconnect to be positioned independent from the flange-mounted handle mechanism.
- Refer to **National Electrical Code®** article 430-10(b) for wiring space "WB" required for line side conductors.
- Refer to Siemens ITE Max-Flex™ installation instructions for limits on disconnect location when using 36" or 48" Max-Flex™ cables.
- Space occupied by disconnect is determined by overall height "X", width "Y", wire bend space "WB" and location "G" as selected from right to left.

†For Two Door Floor-Mount NEMA 12 (Pages G27-G28 & G44-G45) "E" = 7.88 when "H" = 60.12
"E" = 13.38 when "H" = 72.12
(Deduct 1.45 inches from "E" for FHON048 operator mechanism for MD, ND, PD, RD circuit breakers.)

For Heavy-Duty Freestanding and Modular Enclosures (Pages G31 & G48) "E" = 11.88 when "H" = 72.12
"E" = 17.38 when "H" = 84.12
"E" = 20.38 when "H" = 90.12
(Deduct 1.45 inches from "E" for FHON048 operator mechanism for MD, ND, PD, RD circuit breakers.)

**FLOOR-MOUNT • FREESTANDING • MODULAR SERIES ENCLOSURES
DISCONNECT SPACE OCCUPIED & AVAILABLE WIRING SPACE INFORMATION**

SCHNEIDER SQUARE D® CLASS 9422 VARIABLE DEPTH DISCONNECT SWITCHES†

Type Number	Amp Rating	Fuse Clip	Fuse Class	Space Occupied			Wire Bend Space "WB" Above Disconnect				
				F	G*	K	Two Door Floor-Mount (Pages G27-28 & G44-45)		Freestanding & Modular (Pages G31-G48)		
							When H= 60.12 WB	When H= 72.12 WB	When H= 72.12 WB	When H= 84.12 WB	When H= 90.12 WB
TCN-30	30A	No fuse	—	3.8	6.97	0.56	6.75	12.75	10.75	16.75	19.75
TCF-30	30A	30A-250V	H, K, R	5.53	6.97	0.56	6.75	12.75	10.75	16.75	19.75
TCF-33	30A	30A-600V	H, K, R	8.15	6.97	0.56	6.75	12.75	10.75	16.75	19.75
TCF-33	30A	60A-250V	H, K, R	6.15	6.97	0.56	6.75	12.75	10.75	16.75	19.75
TCF-33	30A	30A-600V	J	5.53	6.97	0.56	6.75	12.75	10.75	16.75	19.75
TDN-60	60A	No fuse	—	3.8	6.97	0.56	6.75	12.75	10.75	16.75	19.75
TDF-60	60A	30A-600V	H, K, R	8.15	6.97	0.56	6.75	12.75	10.75	16.75	19.75
TDF-60	60A	60A-250V	H, K, R	6.15	6.97	0.56	6.75	12.75	10.75	16.75	19.75
TDF-63	60A	60A-600V	H, K, R	8.65	6.97	0.56	6.75	12.75	10.75	16.75	19.75
TDF-63	60A	60A-600V	J	5.53	6.97	0.56	6.75	12.75	10.75	16.75	19.75
TEN-10	100A	No fuse	—	3.8	6.97	0.56	6.62	12.62	10.62	16.62	19.62
TEF-10	100A	100A-250V	H, K, R	8.25	6.97	0.56	6.62	12.62	10.62	16.62	19.62
TEF-10	100A	100A-600V	H, K, R	10.25	6.97	0.56	6.62	12.62	10.62	16.62	19.62
TEF-10	100A	100A-600V	J	7.05	6.97	0.56	6.62	12.62	10.62	16.62	19.62
TEF-13	100A	200A-600V	J	—	—	0.56	6.62	12.62	10.62	16.62	19.62
TC-1	30A	No fuse	—	5.75	6.12	0.56	5.88	11.88	9.88	15.88	18.88
TC-2	30A	30A-250V	H, K, R	5.75	6.12	0.56	5.88	11.88	9.88	15.88	18.88
TC-3	30A	30A-600V	H, K, R	7.75	6.12	0.56	5.88	11.88	9.88	15.88	18.88
TC-3	30A	60A-250V	H, K, R	5.88	6.12	0.56	5.88	11.88	9.88	15.88	18.88
TC-3	30A	30A-600V	J	5.75	6.12	0.56	5.88	11.88	9.88	15.88	18.88
TD-1	60A	No fuse	—	6.38	6.75	0.56	6.75	12.75	10.75	16.75	19.75
TD-2	60A	30A-600V	H, K, R	8.5	6.75	0.56	6.75	12.75	10.75	16.75	19.75
TD-2	60A	60A-250V	H, K, R	6.5	6.75	0.56	6.75	12.75	10.75	16.75	19.75
TD-3	60A	60A-600V	H, K, R	9	6.75	0.56	6.75	12.75	10.75	16.75	19.75
TD-3	60A	60A-600V	J	6.38	6.75	0.56	6.75	12.75	10.75	16.75	19.75
TE-1	100A	No fuse	—	4.75	8.5	0.56	6.5	12.5	10.5	16.5	19.5
TE-2	100A	100A-250V	H, K, R	7.5	8.5	0.56	6.5	12.5	10.5	16.5	19.5
TE-2	100A	100A-600V	H, K, R	9.5	8.5	0.56	6.5	12.5	10.5	16.5	19.5
TE-2	100A	100A-600V	J	6.25	8.5	0.56	6.5	12.5	10.5	16.5	19.5
TE-3	100A	200A-600V	J	13.75	8.5	0.56	6.5	12.5	10.5	16.5	19.5
TF-1	200A	No fuse	—	5.5	11.75	0.56	5.12	11.12	9.12	15.12	18.12
TF-2	200A	200A-250V	H, K, R	11.5	11.75	0.56	5.12	11.12	9.12	15.12	18.12
TF-2	200A	200A-600V	H, K, R	14	11.75	0.56	5.12	11.12	9.12	15.12	18.12
TF-2	200A	200A-600V	J	10.12	11.75	0.56	5.12	11.12	9.12	15.12	18.12
TF-3	200A	400A-600V	J	14.5	11.75	0.56	5.12	11.12	9.12	15.12	18.12

†For Two Door Floor-Mount NEMA 12 (Pages G27-G28 & G44-G45)

"E" = 7.88 when "H" = 60.12
"E" = 13.38 when "H" = 72.12

For Heavy-Duty Freestanding and Modular Enclosures (Pages G31 & G48)

"E" = 11.88 when "H" = 72.12
"E" = 17.38 when "H" = 84.12
"E" = 20.38 when "H" = 90.12

FLOOR-MOUNT • FREESTANDING • MODULAR SERIES ENCLOSURES DISCONNECT SPACE OCCUPIED & AVAILABLE WIRING SPACE INFORMATION

SCHNEIDER SQUARE D® CLASS 9422 VARIABLE DEPTH OPERATOR CIRCUIT BREAKERS†

Type Number	Amp Rating	Fuse Clip	Fuse Class	Wire Bend Space "WB" Above Disconnect							
				Space Occupied			Two Door Floor-Mount (Pages G27-28 & G44-45)		Freestanding & Modular (Pages G31-G48)		
				F	G*	K	When H= 60.12 WB	When H= 72.12 WB	When H= 72.12 WB	When H= 84.12 WB	When H= 90.12 WB
RG-1	75A	GJL	3.53	3.87	0.56	6.69	12.69	10.69	16.69	19.69	19.75
RG-1	100A	GJL	3.53	3.87	0.56	6.69	12.69	10.69	16.69	19.69	19.75
RN-1	100A	FAL, FHL	5.12	5.38	0.56	6.88	12.88	10.88	16.88	19.88	19.75
RP-1	250A	KAL, KHL	7.12	5.75	0.56	7.56	13.06	11.56	17.56	20.56	19.75
RR-1	400A	LAL,LHL,Q4L	7.62	8.88	0.56	—	9.25	—	13.25	16.25	19.75
RT-1	800A	MEL, MXL	9.12	12	0.56	—	—	—	13.25	16.25	19.75
RT-1	1000A	MAL, MHL	9.12	12	0.56	—	—	—	13.25	16.25	19.75

SCHNEIDER SQUARE D® CLASS 9422 DISCONNECT SWITCHES USED WITH CABLE MECHANISM 9422-CFT30 AND 9422-A1 HANDLE MECHANISM

Switch	Amp Rating	Fuse Clip	Fuse Class	Disconnect Height X	Disconnect Width Y	Two Door Floor-Mount	Freestanding & Modular
TCN-30C	30A	No fuse	—	5.9	6.2		
TCF-30C	30A	30A-250V	H, K, R	7.5	6.2		
TCF-33C	30A	30A-600V	H, K, R	10.15	6.2		
TCF-33C	30A	60A-250V	H, K, R	8.15	6.2		
TCF-33C	30A	30A-600V	J	7.5	6.2		
TDN-60C	60A	No fuse	—	5.9	6.2		
TDF-60C	60A	30A-600V	H, K, R	10.15	6.2	For enclosures that accept these devices, (See pages G27-G28 & G44-G45)	For enclosures that accept these devices, (See pages G31-G48)
TDF-60C	60A	60A-250V	H, K, R	8.15	6.2		
TDF-63C	60A	60A-600V	H, K, R	10.65	6.2		
TDF-63C	60A	60A-600V	J	7.5	6.2		
TEN-10C	100A	No fuse	—	5.9	6.2		
TEF-10C	100A	100A-250V	H, K, R	10.35	6.2		
TEF-10C	100A	100A-600V	H, K, R	10.35	6.2		
TEF-10C	100A	100A-600V	J	10.35	6.2		

Use switches listed above with appropriate cable mechanism and 9422-A1 handle mechanism. Cable operators are available in 3-foot, 5-foot, and 10-foot lengths. Numbers shown (30) are for 3-foot cables.

SCHNEIDER SQUARE D® CLASS 9422 CABLE MECHANISM FOR CIRCUIT BREAKERS

Cable Type Switch	Circuit B Amp Rating	Circuit B Frame Type	Circuit Breaker Height X	Circuit Breaker Height Y	Two Door Floor-Mount	Freestanding & Modular
9422 CGJ30	75A	GJL	4.75	3.5		
9422 CGJ30	100A	GJL	4.75	3.5		
9422 CFA30	100A	FAJ, FHL	6	4.5	For enclosures that accept these devices, (See pages G27-G28 & G44-G45)	For enclosures that accept these devices, (See pages G31-G48)
9422 CKA30	250A	KAL, KHL	8	4.5		
9422 CLA30	400A	LAL, LHL, Q4L	11	6		

Use cable mechanism with appropriate circuit breaker and 9422-A1 handle mechanism. Cable operators are available in 3-foot, 5-foot, and 10-foot lengths. Numbers shown (30) are for 3-foot cables.

Space Occupied by Disconnect Switch or Circuit Breaker

- Schneider Square D® cable mechanisms allows disconnect devices to be positioned independent from the flange-mounted handle mechanism.
- Refer to National Electrical Code® article 430-10(b) for wiring space "WB" required for line side conductors.
- Choose cable mechanism length based on placement of disconnect in enclosure. See Schneider Square D® instruction Bulletin for minimum bend radius for cable.
- Space occupied by disconnect is determined by overall height "X", width "Y", wire bend space "WB" and location "G" as selected from right to left.

†For Two Door Floor-Mount NEMA 12
(Pages G27-G28 & G44-G45)

"E" = 7.88 when "H" = 60.12
"E" = 13.38 when "H" = 72.12

For Heavy-Duty Freestanding
and Modular Enclosures
(Pages G31 & G48)

"E" = 11.88 when "H" = 72.12
"E" = 17.38 when "H" = 84.12
"E" = 20.38 when "H" = 90.12



WA21ABA



WA22BAP

FEATURES-SPECIFICATIONS

OPERATOR ADAPTER PLATES

- Used on all disconnect enclosures with universal flange cutouts
- An operator adapter plate is required to install a disconnect in all enclosures with a universal cutout on pages G27-G48.
- Operator adapters include an adapter plate and additional parts used to interlock the master door with the disconnect operating mechanism. Panel drilling and installation instructions are furnished with each adapter
- Each brand and type of disconnect requires a different operator adapter. It is important to select the proper operator adapter and enclosure for the disconnect that you have selected

BLANK ADAPTER PLATES

- Used to cover flange cutouts in disconnect enclosures when disconnects are not installed. This greatly increases the versatility of the disconnect enclosures, enabling them to also be used as a regular NEMA 12 enclosure
- Blank adapter plates are made from heavy gauge steel, with a oil-resistant gasket to maintain the dust-tight and oil-tight qualities of the enclosure
- All blank adapter plates are painted ANSI 61 gray polyester powder
- All necessary mounting hardware and instructions are included

OPERATOR ADAPTER PLATES

Catalog Number	Type of Operator Adapter
WA21ABA	Allen-Bradley 1494F and 1494D
WA21ABVA	Allen-Bradley 1494V, 140U, 1494C, 194RC
WA21CHVA	Eaton Cutler-Hammer C361, C371 and C371 Flex Shaft™
WA21CHVA	ABB Controls Variable Depth, S1, S2, T5 cable size
WA21FUFA	Fuji
WA21GETDA	General Electric STDA
WA21ITE	Siemens ITE Max-Flex™, ABB Controls Cable S3-S5, S6, S7
WA21SDA	Schneider Square D® Class 9422, (variable depth and cable mechanism)
WA21WHA	Eaton Cutler-Hammer/WestinghouseSM

BLANK ADAPTER PLATES

Catalog Number	Type of Operator Adapter
WA21BAP	Blank adapter for universal cutouts on pages G27- G48
WA22BAP	Blank adapter for enclosures on page G24
WA3456BAP	Blank adapter for single door wall-mount enclosures on pages G2- G13.