

Section M

General Information/Sizing M2-M3

Guardian/Guardian X Series Air Conditioners M4

SlimKool Series Air Conditioners M13

Micro-Mini Series Air Conditioners M17

Compact Top Mount Series Air Conditioners

Vortex Coolers M19

FBF Series
Filtered Box Fans & Grilles M21-22

WAAXFN/WAGARD Series
Muffin Fans & Finger Guards M23

WAVK/WAFLT Series
Louver Plate & Filter Kits M24

RH/RHPC Series Radiant Heaters M26

WHVL Series Fan Heaters M27

FH Series Fan Heaters M28-30

TAN/TTA/TCT Series Thermostats M31

Thermostats/Humidistats/Hygrostats M32

STFX Series
Universal Thermostat Mount M33

WAFMP Series
Fan Mounting Plate Kit M34

FF Series Filter Fans
Filter Fan/Exhaust Filter/Mats M35-36

FF Series Filterfans M37-39

FFA Series Exhaust Grilles & Filter M40

ENVIRONMENTAL CONTROL



Wiegmann has always recognized that our customers in the electrical and electronic marketplace need reliable, high quality enclosures and environmental control products to meet their protection requirements. Protection Requirements today not only mandate NEMA TYPE 12, 3R, 4, & 4X, but also require a broad mix of BTU & size selections. Wiegmann is proud to offer those choices via a whole new line of A/C products. They are: Advantage Series, Trim Line Series, Micro-Mini Series, Integrity Series, and the Top Mount Series.

Three Basic Cooling Methods

When selecting a cooling method there are three types to consider.

1 *Passive Ventilation* — If there is only a minimal heat gain in your

circumstance, use of louvers or grilles with filters can be effective. This method, however, usually provides less cooling effect than is necessary with today's components.

2 *Forced Convection Air Cooling* — If the installation will be in a clean, non-hazardous environment with an acceptable ambient (outside the enclosure) temperature range, a simple forced-air cooling system utilizing outside air is usually adequate. Combined with an air filter, such devices generally meet the heat removal needs of typical electronic equipment and many electrical applications (Fig. 1). Examples of forced convection air cooling are filtered fans, fan trays, and blowers of various types.

3 *Closed-Loop Cooling* — In harsh environments involving high temperatures, wash-down requirements, heavy particulate matter or the presence of chemicals capable of damaging components (NEMA 4 or 12 environments), ambient air must be kept out of the enclosure. Closed-loop cooling consists of two separate circulation systems. One system, sealed against the ambient air, cools and recirculates the clean cool air throughout the enclosure. The second system uses ambient air or water to remove and discharge the heat. Examples of closed-loop cooling equipment employed with electronics and process controls are heat exchangers and air conditioners.

FIGURE 1 — Forced Convection Method

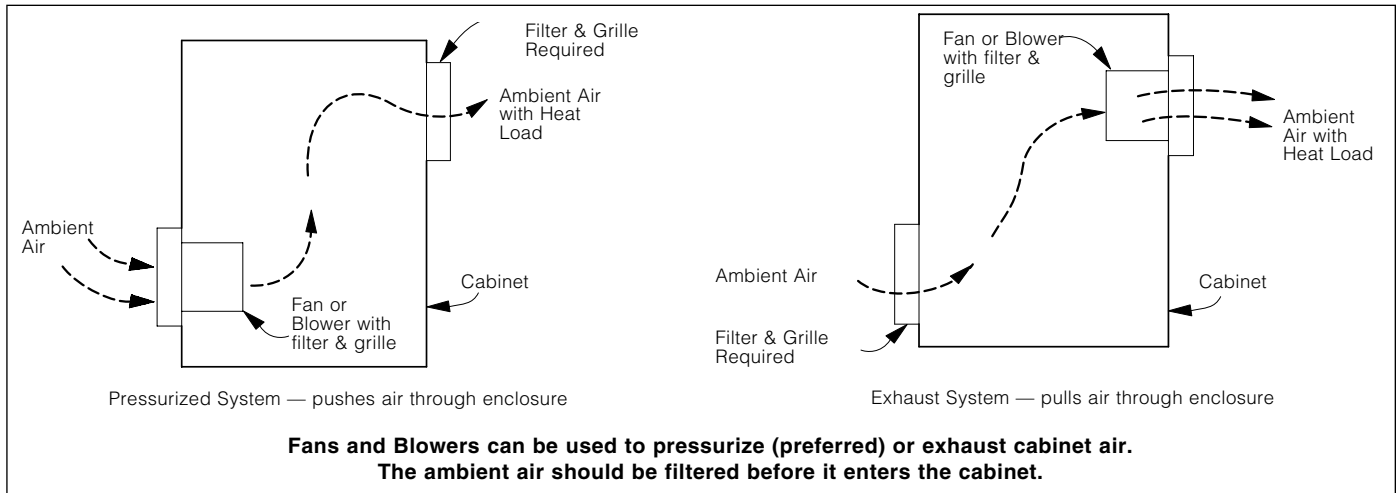
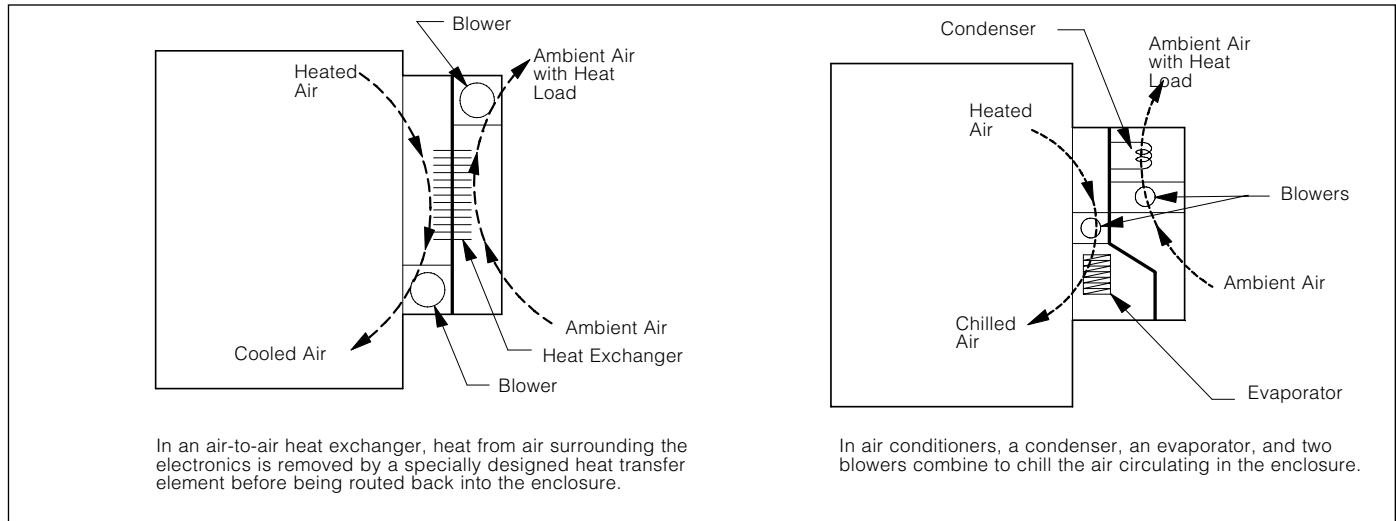

FIGURE 2 - Closed Loop Cooling Method



Cooling Control Cabinets

Most electrical & electronic control systems generate a substantial amount of heat during operation. This heat factor is intensified as controls are made more compact, perform more functions, and are placed in more confined areas. Additional problems are encountered when the electronic process control system is located on-site in an industrial setting, rather than in a clean computer room. The factory environment can be hostile to the point that performance and effective life of the electronic components are materially reduced, or the control system fails completely. Ambient temperature might be excessively high, as that found in a steel mill. Moisture-laden air and air-borne particulate matter might be present to adversely affect the electronic components, as in the paper manufacturing industry.

Air conditioners are designed to perform reliably under many of these harsh conditions and to provide the cooling and environmental protection required by sensitive electronic production control systems.

Factors Affecting Model Selection

This selection is presented as a basic outline or checklist of the various conditions to be considered when choosing a cooling unit for a certain application. The following are factors which must be considered when selecting a cooling unit:

Internal Heat Load — This is the heat dissipated by the electronic controls. It is expressed in watts. One watt equals 3.413 BTU/HR. Thus, to obtain the approximate cooling capacity required to remove a specific heat load, the following formula can be used:

$$\text{Watts} \times 3.413 = \text{BTU/HR}$$

For example, a heat load of 800 watts requires an air conditioner capable of removing at least 2,730 BTU/HR.

Resistance to Air Flow in the Enclosure

Air Flow is measured in cubic feet per minute (CFM). To create an air flow of any desired velocity requires that pressure be produced by the blower in the air conditioner. Resistance to this blower-produced air flow is created by obstruction within the cabinet in the air flow path. The resistance itself is called pressure drop (P.D.) and is measured in inches of water column.

The effect of significant restrictions in the cabinet air flow path are as follows: The obstructions cause pressure drops, which leads to cool air flow reduction. This reduction in cool air flow will decrease the effective capacity of the cooling unit. When selecting the proper cooling unit, allowance must be made for pressure drop.

Heat Load From The Surroundings

Ambient conditions can cause a heat gain in the enclosure. The rated capacity of the cooling unit must be sufficient to handle this heat gain. When evaluating the additional heat load gained from the surroundings, the subject more or less breaks down into two situations: (1) the cabinet is insulated and well sealed, or (2) the cabinet is not insulated (most cabinets are uninsulated.)

(1) Cabinet Insulated — Normally, well insulated cabinets will not gain sufficient ambient heat to affect air conditioner's operation. Maximum operating temperature for our air conditioners is 125°F. When the air conditioner operates in ambient temperatures below 125°F, the cooling capacity of the air conditioner substantially increases.

(2) Cabinet Not Insulated — Obviously, this design placed more of a burden on the cooling unit. Heat is conducted to the cool side. Thus, high ambient heat will be readily transmitted into the cooler enclosure. To determine the additional capacity required of our air conditioner installed in an uninsulated cabinet, the surface square footage of the enclosure must be

calculated to obtain the total effective heat transfer area. For this calculation, use the surface area of the sides, plus the area of the top, and omit the bottom area of the cabinet.

Air movement outside the uninsulated cabinet will increase the heat conducted from the ambient into the enclosure. When there is little or no air circulation outside the cabinet, the layer of air immediately adjacent to the exterior cabinet walls acts as an insulating film. Exterior air movement dissipates this insulating layer of air in proportion to the velocity of the air flow. Substantial ambient air circulation will increase the transmitted heat load imposed on the cooling unit.

If the cabinet being cooled is not air tight, then high ambient relative humidity will adversely affect the cooling effectiveness of the air conditioner. When humid air infiltrates a poorly sealed enclosure, the air conditioner is required to use up valuable BTU/HR capacity just to condense the moisture from the internal air. Conversely, if the cabinet is well sealed, high ambient relative humidity, has very little effect on the heat capacity of the air conditioner.

Steps For Sizing an Air Conditioner

Proper selection of an air conditioner is determined by the following criteria:

- Required cooling capacity BTU/hr. (complete Steps #1-4)
- Mounting requirements (top or side mounting options)
- Dimension of air conditioner and enclosure

Cooling And Control Cabinets

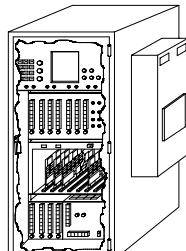
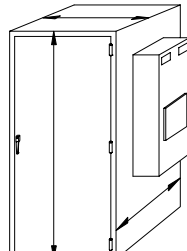
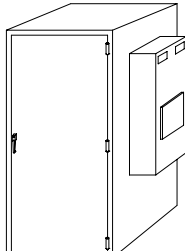
STEP ONE	STEP TWO	STEP THREE	STEP FOUR
			<p><i>(Watts x 3.413) + [1.25 x Area ft.2 x Δ T (°F)] =BTU/HR.</i></p> <p><i>Capacity Required BTU/HR. Capacity Rating</i></p>
<p><i>1 Watt = 3.413 BTU/HR. Determine the internal heat load in Watts that must be dissipated.</i></p>	<p><i>1 m2 = 10.76 ft.2 Calculate the exposed surface area of the enclosure: 2(h' x w') + 2(h' x d') + (w' x d') = Area (ft2)</i></p>	<p><i>1oC or 1oKΔT=1.8oF T Determine the temperature differential by subtracting the maximum allowable temperature inside the enclosure (Ti) from the maximum ambient temperature outside the enclosure (To) To-Ti=ΔT</i></p>	

**ENVIRONMENTAL CONTROLS
GUARDIAN/GUARDIAN X SERIES SIDE-MOUNT AIR CONDITIONERS**



Industry Standards
NEMA 3R, 4, 4X, & 12
UL50



FEATURES-SPECIFICATIONS

The Guardian Series consists of units with heights from 15 to 60 inches, offering 1,000 to 26,000 BTU/H ratings. Available in painted steel or stainless steel and 115, 230, or 480 volts.

The features engineered into the Guardian Series make them a tamper-resistant choice for external applications. With all models UL/

CUL Listed, the Guardian Series is an excellent choice for telecommunications, food and beverage and other challenging applications.

- Available in Painted Steel or Stainless Steel (4X Models Only)
- Built-in Condensate Evaporator
- Closed-Loop Cooling

- Condenser Blower Controller
- Epoxy-Coated Evaporator and Condenser Coils
- Internal Corrosion Protection
- Programmable Thermostat
- Programmable Temperature Alarm
- Filters
- Zero ODP Refrigerant

SEE PAGES M5-M12 FOR DIAGRAMS AND DIMENSIONAL DRAWINGS

	Overall Size (H x W x D)	NEMA Rating	Volts	HZ	95/95 Rating BTU/H	Running Amps	Ambient Temp Max/Min	Approx Weight (lb)
DP 15 Series (1,000 BTU/H)								
WNA4C1DP15L	15 x 8 x 7	4	115	60	950	4.3	131/-20	26
WNA4C1DP15LV*	15 x 8 x 7	4X	115	60	950	4.3	131/-20	26
DP 21 Series (3,000 BTU/H)								
WNA4C3DP21L	21 x 12 x 10	4	115	60	2470	6.0	131/-20	54
WNA4C3DP21LV*	21 x 12 x 10	4X	115	60	2470	6.0	131/-20	54
DP 24 Series (3,000 BTU/H)								
W2NA4C3DP24L	24 x 12 x 10	4	230	60	2500	3.0	125/-20	61
W2NA4C3DP24LV*	24 x 12 x 10	4X	230	60	2500	3.0	125/-20	61
W3NA4C3DP24L	24 x 12 x 10	4	480	60	2500	1.4	125/-20	61
W3NA4C3DP24LV*	24 x 12 x 10	4X	480	60	2500	1.4	125/-20	61
DP 33 Series (5,000 BTU/H)								
WNA4C5DP33L	33 x 17 x 11	4	115	60	4000	10.6	131/-20	95
WNA4C5DP33LV*	33 x 17 x 11	4X	115	60	4000	10.6	131/-20	95
W2NA4C5DP33L	33 x 17 x 11	4	230	60	4000	4.5	131/-20	95
W2NA4C5DP33LV*	33 x 17 x 11	4X	230	60	4000	4.5	131/-20	95
DP 38 Series (5,000 BTU/H)								
W3NA4C5DP38L	39 x 17 x 11	4	480	60	4800	2.0	131/0	115
W3NA4C5DP38LV*	39 x 17 x 11	4X	480	60	4800	2.0	131/0	115
DP 43 Series (7,000 BTU/H)								
WNA4C7DP43L	43 x 17 x 10	4	115	60	5500	13.8	131/-20	125
WNA4C7DP43LV*	43 x 17 x 10	4X	115	60	5500	13.8	131/-20	125
W2NA4C7DP43L	43 x 17 x 10	4	230	60	5500	6.7	131/-20	125
W2NA4C7DP43LV*	43 x 17 x 10	4X	230	60	5500	6.7	131/-20	125

continued on page M5

	Overall Size (H x W x D)	NEMA Rating	Volts	HZ	95/95 Rating BTU/H	Running Amps	Ambient Temp Max/Min	Approx Weight (lb)
DP 47 Series (9,000 BTU/H)								
WNA4C9DP47L	47 x 17 x 10	4	115	60	7400	19.2	131/-20	135
WNA4C9DP47LV*	47 x 17 x 10	4X	115	60	7400	19.2	131/-20	135
W2A4C9DP47L	47 x 17 x 10	4	230	60	7400	9.0	131/-20	135
W2A4C9DP47LV*	47 x 17 x 10	4X	230	60	7400	9.0	131/-20	135
DP 50 Series (14,000 BTU/H)								
W2NA6C14DP50L	50 x 20 x 12	4	230	60	13000	13.5	131/-20	207
W2NA6C14DP50LV*	50 x 20 x 12	4X	230	60	13000	13.5	131/-20	207
W3NA6C14DP50L	50 x 20 x 12	4	480	60	13000	5.0	131/-20	207
W3NA6C14DP50LV*	50 x 20 x 12	4X	480	60	13000	5.0	131/-20	207
DP 52 Series (7,000 and 9,000 BTU/H)								
W3NA4C7DP52L	52 x 17 x 10	4	480	60	6300	3.0	131/0	160
W3NA4C7DP52LV*	52 x 17 x 10	4X	480	60	6300	3.0	131/0	160
W3NA4C9DP52L	52 x 17 x 10	4	480	60	8100	4.0	131/0	164
W3NA4C9DP52LV*	52 x 17 x 10	4X	480	60	8100	4.0	131/0	164
DP 53 Series (18,000 BTU/H)								
W2NA6C18DP53L	53 x 22 x 13	4	230	60	15800	20.0	125/-20	224
W2NA6C18DP53LV*	53 x 22 x 13	4X	230	60	15800	20.0	125/-20	224
W3NA6C18DP53L	53 x 22 x 13	4	480	60	15800	5.7	125/-20	224
W3NA6C18DP53LV*	53 x 22 x 13	4X	480	60	15800	5.7	125/-20	224
DP 60 Series (26,000 BTU/H)								
W2NA6C26DP60L	60 x 24 x 13	4	230	60	22800	24.0	131/-20	262
W2NA6C26DP60LV*	60 x 24 x 13	4X	230	60	22800	24.0	131/-20	262
W3NA6C26DP60L	60 x 24 x 13	4	480	60	22800	7.4	131/-20	262
W3NA6C26DP60LV*	60 x 24 x 13	4X	480	60	22800	7.4	131/-20	262

*STAINLESS STEEL NEMA 4X MODEL

DP 15 Series (1,000 BTU/H)

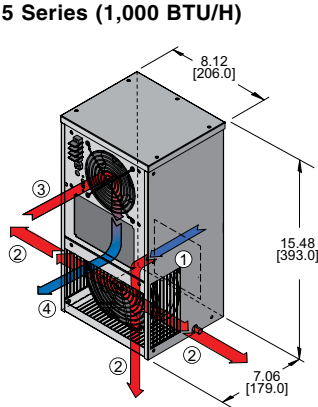

- ① FILTERED CONDENSER AIR INLET (Ambient Air In)
- ② CONDENSER OUTLET (Warm Ambient Air Out)
- ③ WARM AIR RETURN FROM ENCLOSURE
- ④ COOL AIR OUTLET TO ENCLOSURE

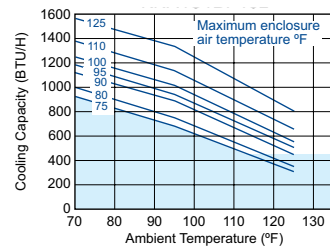
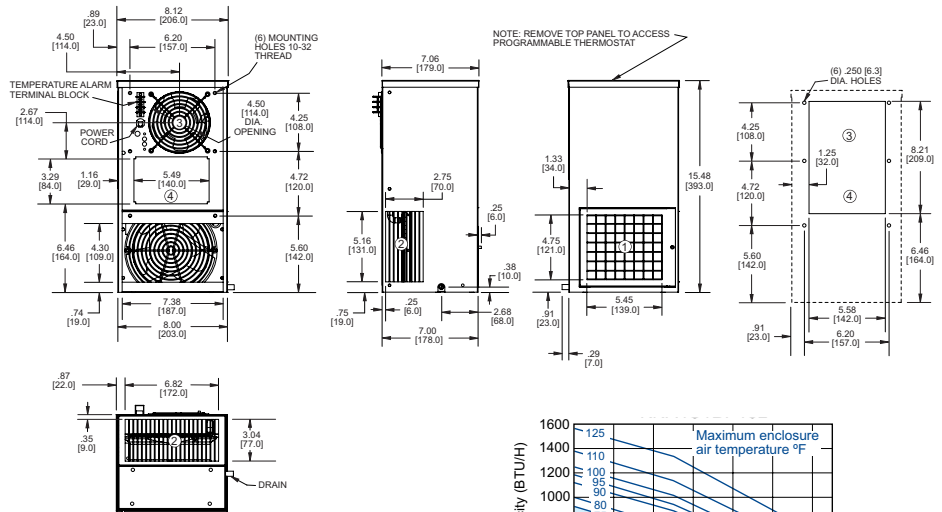

DP 21 Series (3,000 BTU/H)

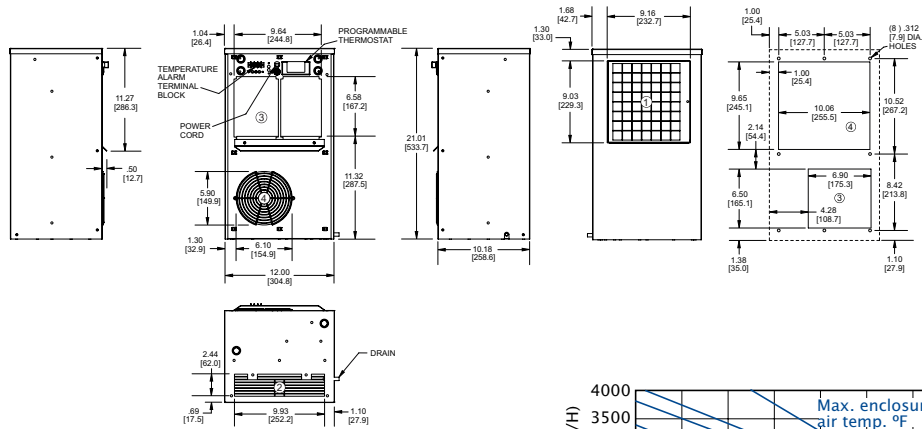
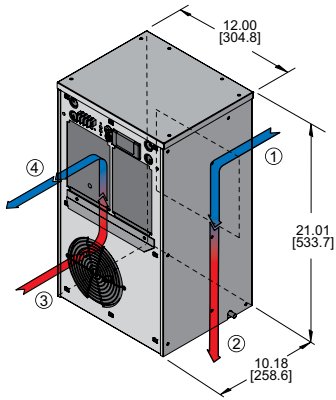

- ① FILTERED CONDENSER AIR INLET (Ambient Air In)
- ② CONDENSER OUTLET (Warm Ambient Air Out)
- ③ WARM AIR RETURN FROM ENCLOSURE
- ④ COOL AIR OUTLET TO ENCLOSURE

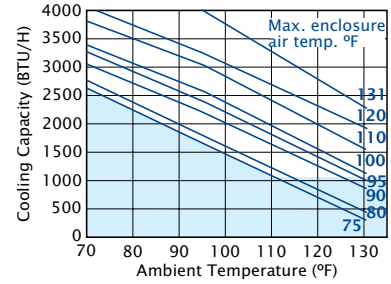

DP 24 Series (3,000 BTU/H)

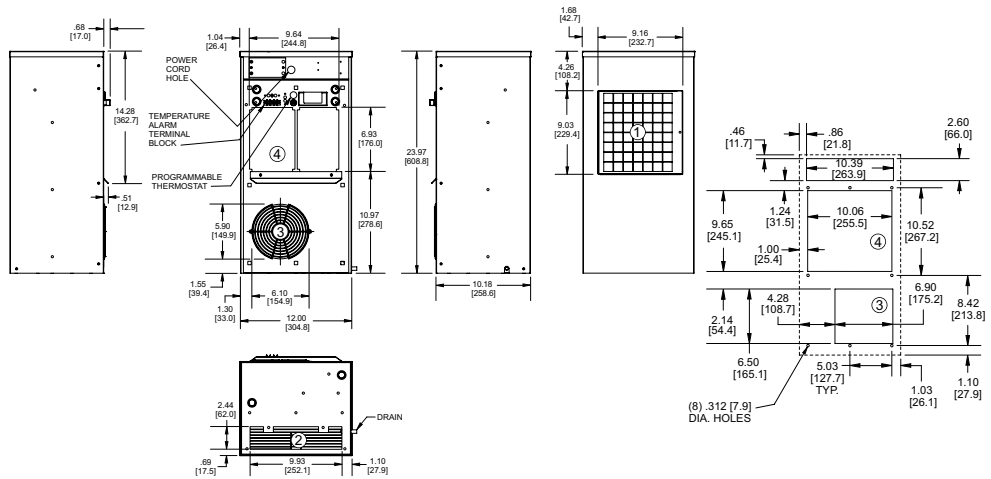
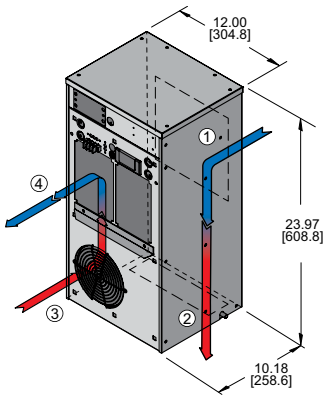

- ① FILTERED CONDENSER AIR INLET (Ambient Air In)
- ② CONDENSER OUTLET (Warm Ambient Air Out)
- ③ WARM AIR RETURN FROM ENCLOSURE
- ④ COOL AIR OUTLET TO ENCLOSURE

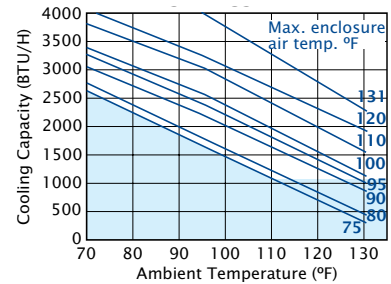

DP 33 Series (5,000 BTU/H)

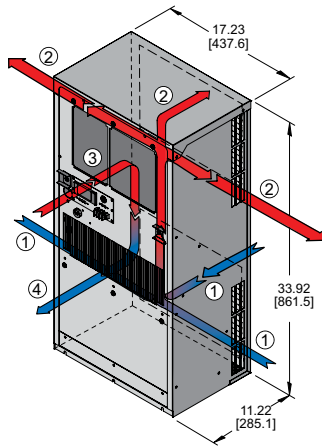

- ① FILTERED CONDENSER AIR INLET (Ambient Air In)
- ② CONDENSER OUTLET (Warm Ambient Air Out)
- ③ WARM AIR RETURN FROM ENCLOSURE
- ④ COOL AIR OUTLET TO ENCLOSURE

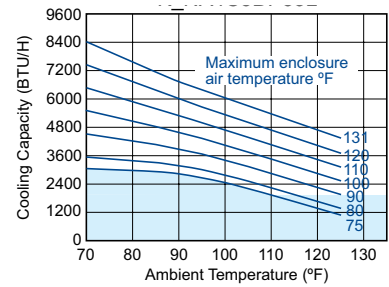
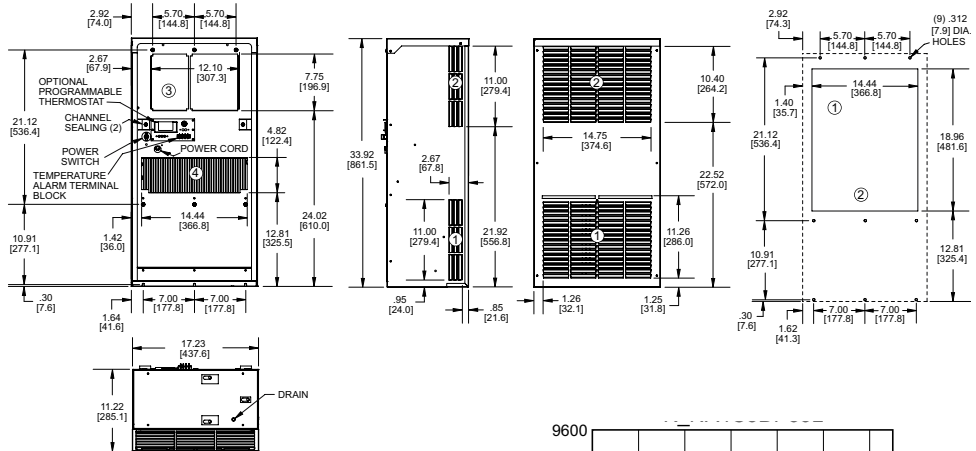

DP 38 Series (5,000 BTU/H)

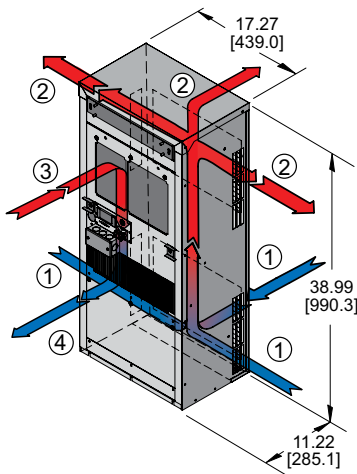

- ① FILTERED CONDENSER AIR INLET (Ambient Air In)
- ② CONDENSER OUTLET (Warm Ambient Air Out)
- ③ WARM AIR RETURN FROM ENCLOSURE
- ④ COOL AIR OUTLET TO ENCLOSURE

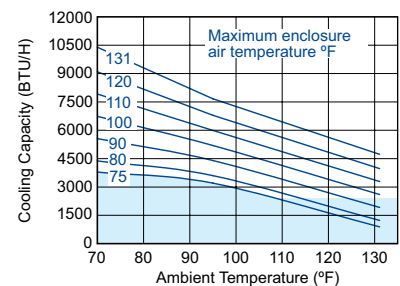
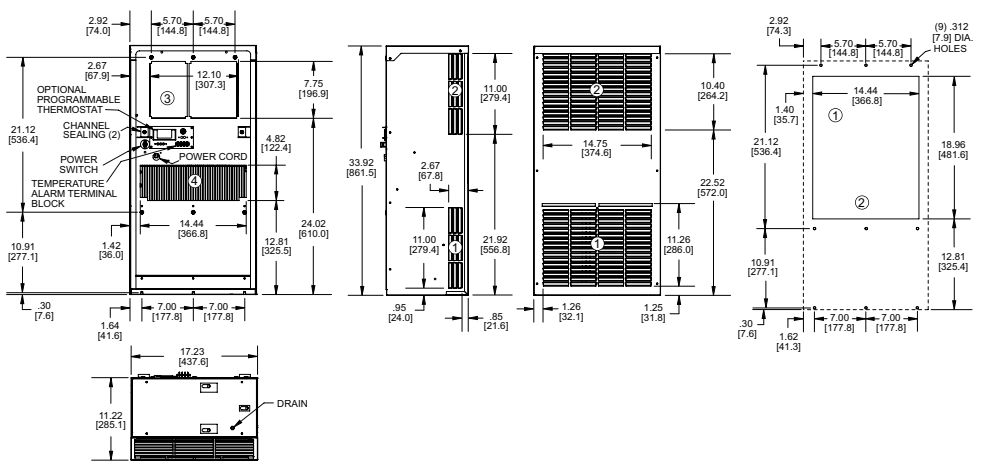

DP 43 Series (7,000 BTU/H)

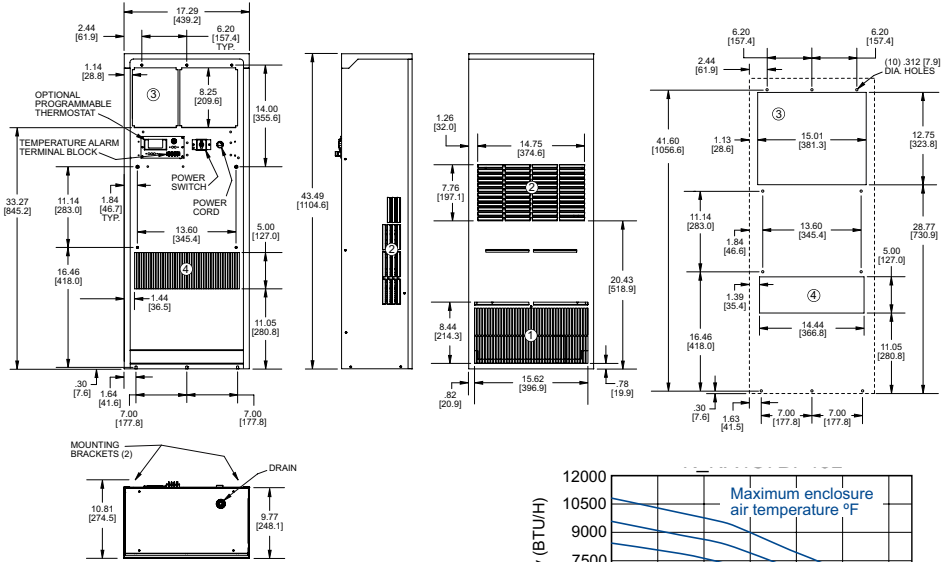
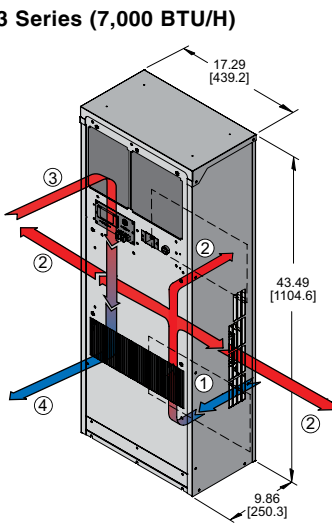

- ① FILTERED CONDENSER AIR INLET (Ambient Air In)
- ② CONDENSER OUTLET (Warm Ambient Air Out)
- ③ WARM AIR RETURN FROM ENCLOSURE
- ④ COOL AIR OUTLET TO ENCLOSURE

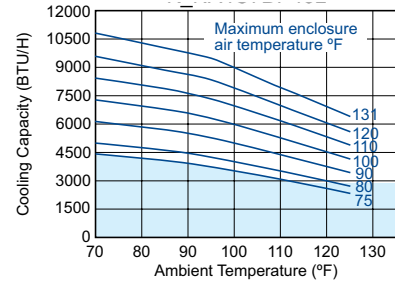

DP 47 Series (9,000 BTU/H)

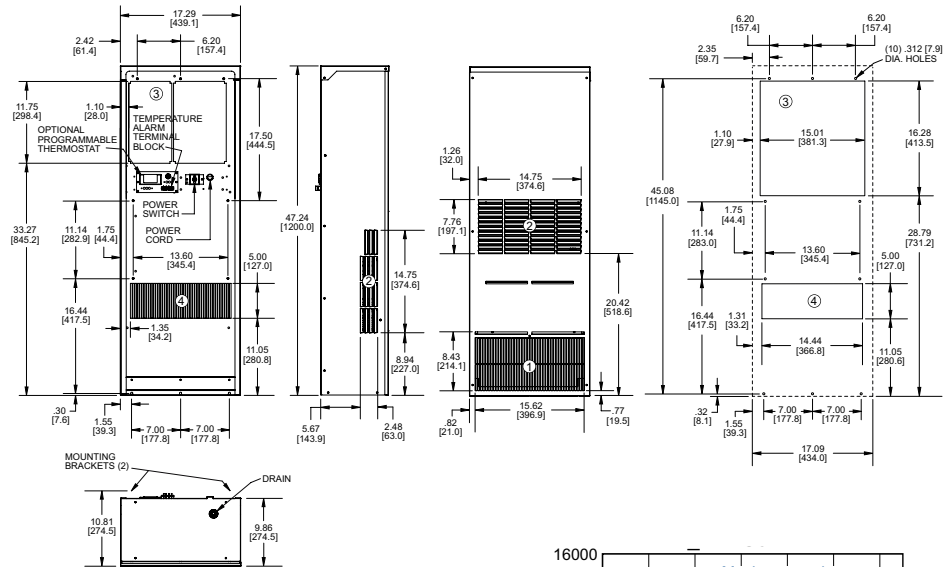
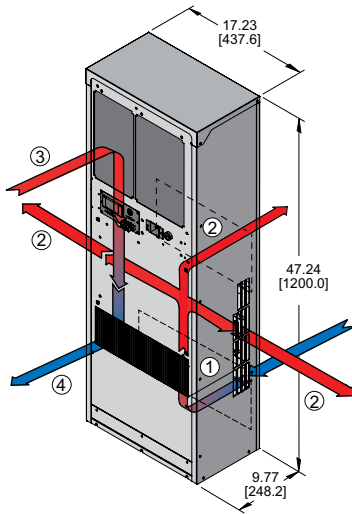

- ① FILTERED CONDENSER AIR INLET (Ambient Air In)
- ② CONDENSER OUTLET (Warm Ambient Air Out)
- ③ WARM AIR RETURN FROM ENCLOSURE
- ④ COOL AIR OUTLET TO ENCLOSURE

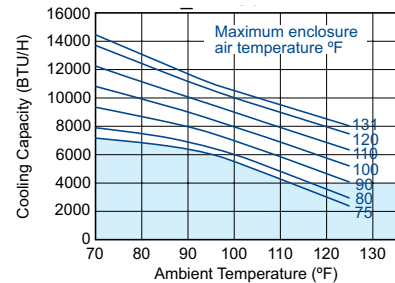

DP 50 Series (14,000 BTU/H)

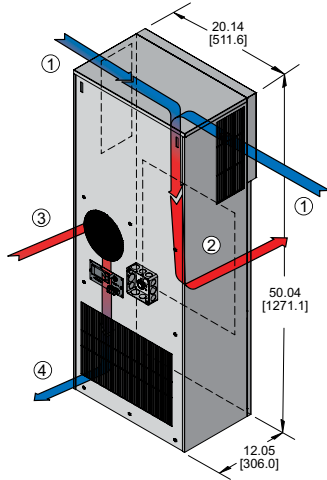

- ① FILTERED CONDENSER AIR INLET (Ambient Air In)
- ② CONDENSER OUTLET (Warm Ambient Air Out)
- ③ WARM AIR RETURN FROM ENCLOSURE
- ④ COOL AIR OUTLET TO ENCLOSURE

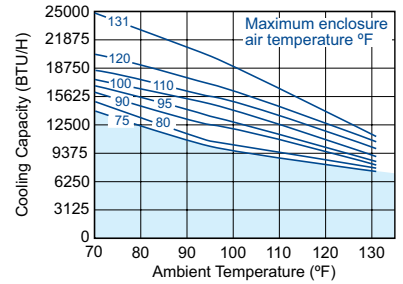
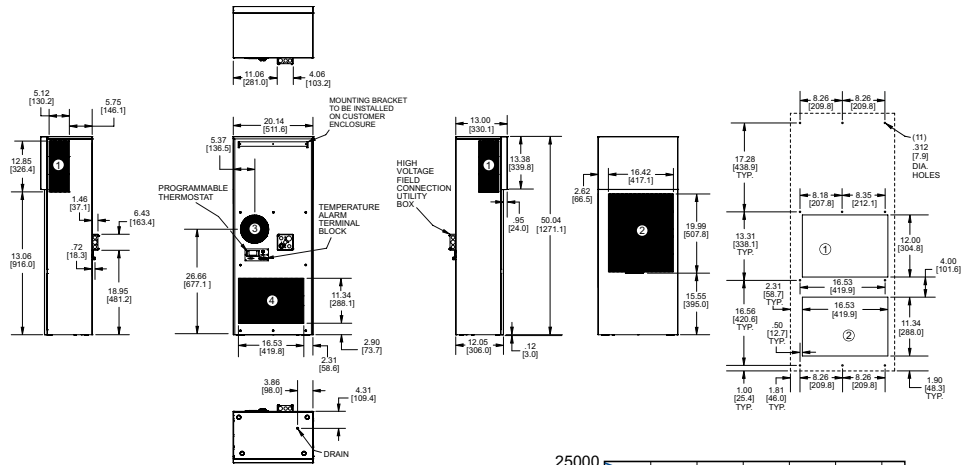

DP 50 480V Series (14,000 BTU/H)

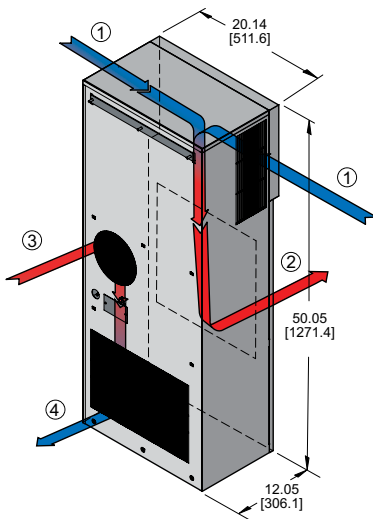

- ① FILTERED CONDENSER AIR INLET (Ambient Air In)
- ② CONDENSER OUTLET (Warm Ambient Air Out)
- ③ WARM AIR RETURN FROM ENCLOSURE
- ④ COOL AIR OUTLET TO ENCLOSURE

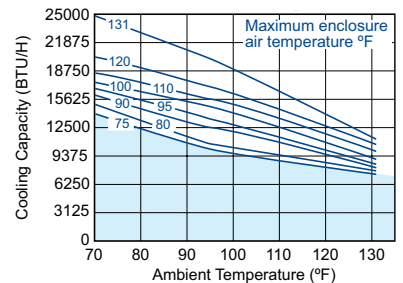
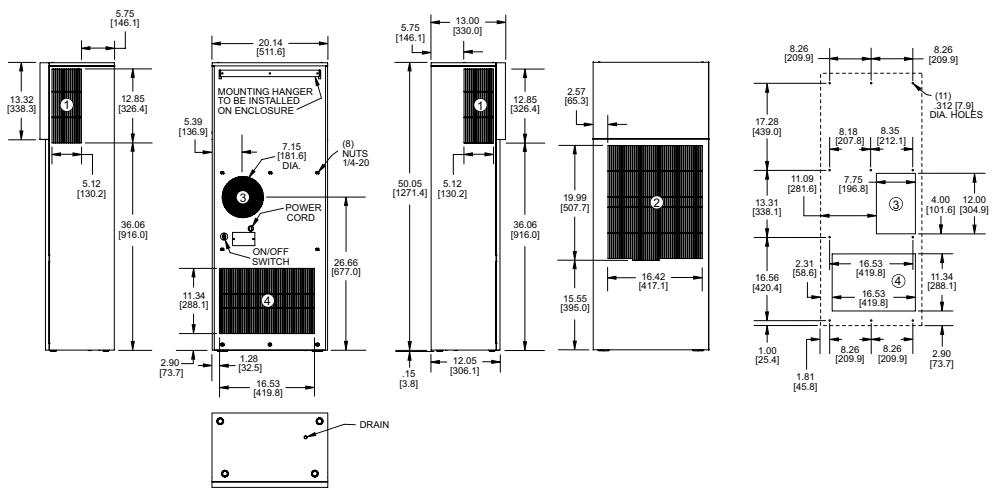

DP 52 480V Series (7,000 and 9,000 BTU/H)

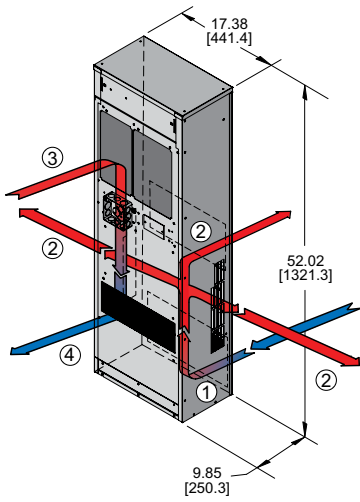

- ① FILTERED CONDENSER AIR INLET (Ambient Air In)
- ② CONDENSER OUTLET (Warm Ambient Air Out)
- ③ WARM AIR RETURN FROM ENCLOSURE
- ④ COOL AIR OUTLET TO ENCLOSURE

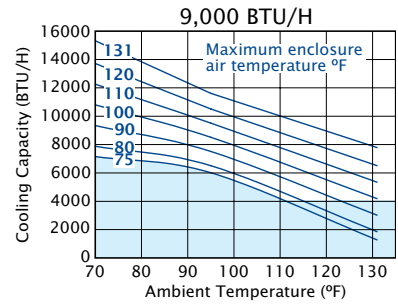
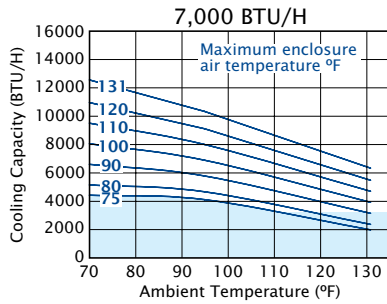
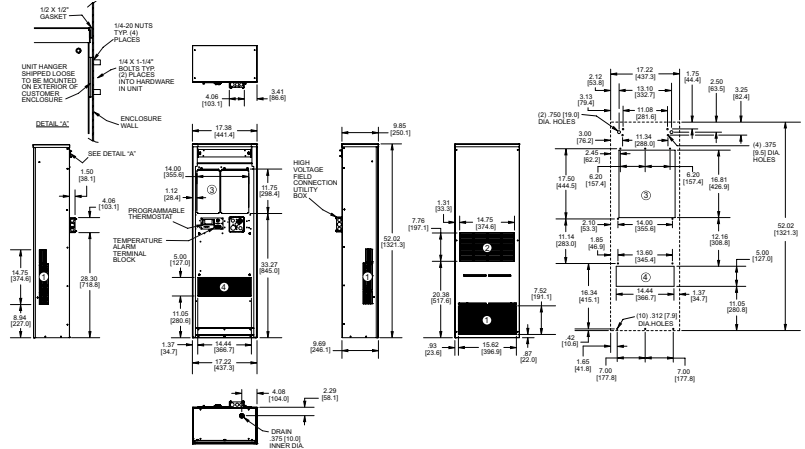

DP 53 480V Series (18,000 BTU/H)

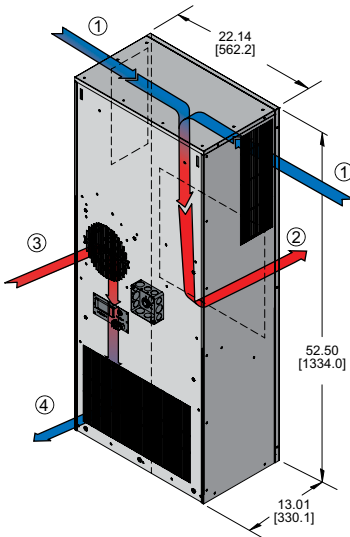

- ① FILTERED CONDENSER AIR INLET (Ambient Air In)
- ② CONDENSER OUTLET (Warm Ambient Air Out)
- ③ WARM AIR RETURN FROM ENCLOSURE
- ④ COOL AIR OUTLET TO ENCLOSURE

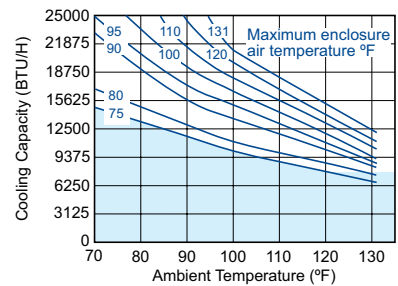
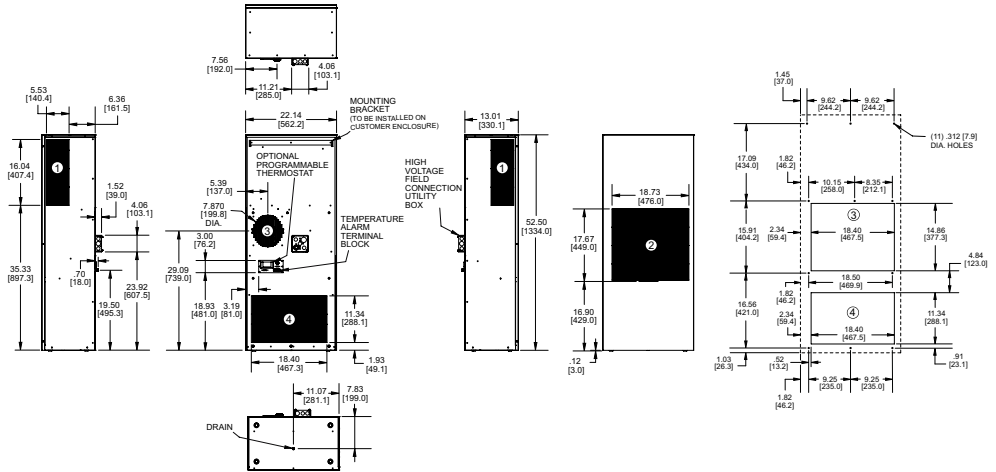

DP 53 Series (18,000 BTU/H)

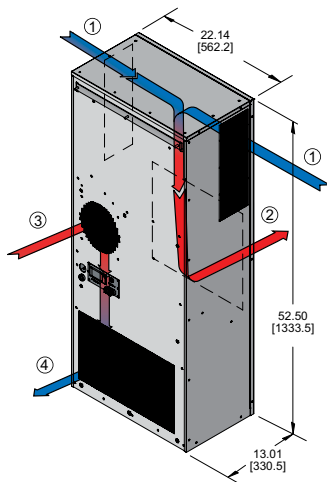

- ① FILTERED CONDENSER AIR INLET (Ambient Air In)
- ② CONDENSER OUTLET (Warm Ambient Air Out)
- ③ WARM AIR RETURN FROM ENCLOSURE
- ④ COOL AIR OUTLET TO ENCLOSURE

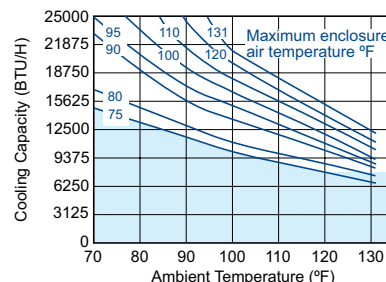
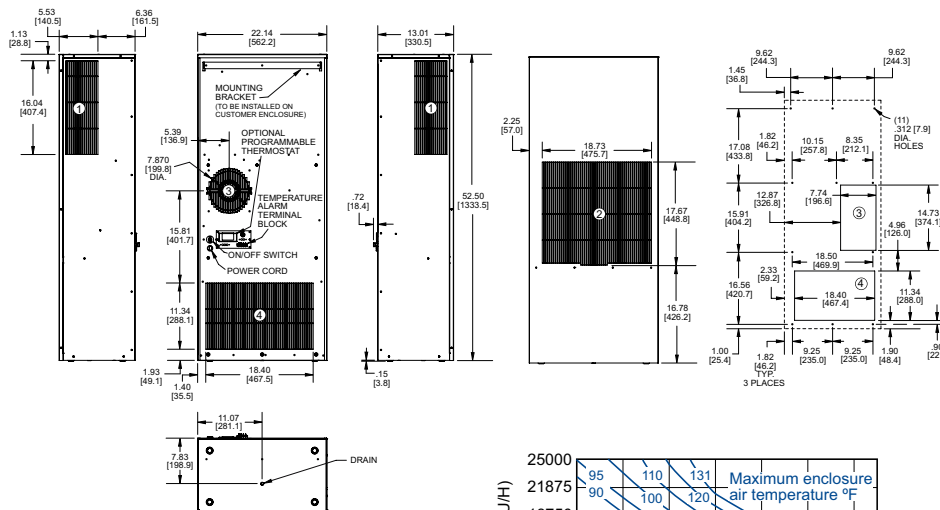

DP 60 480V Series (26,000 BTU/H)

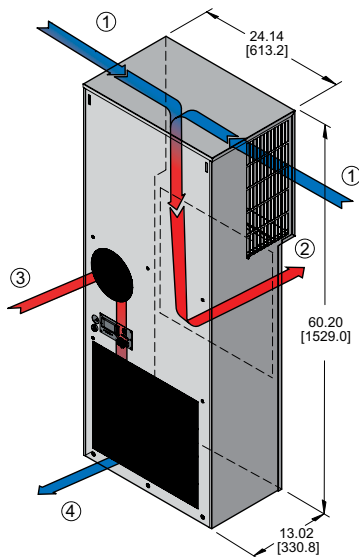

- ① FILTERED CONDENSER AIR INLET (Ambient Air In)
- ② CONDENSER OUTLET (Warm Ambient Air Out)
- ③ WARM AIR RETURN FROM ENCLOSURE
- ④ COOL AIR OUTLET TO ENCLOSURE

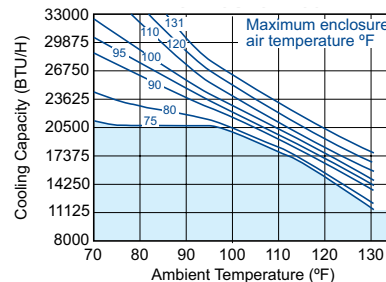
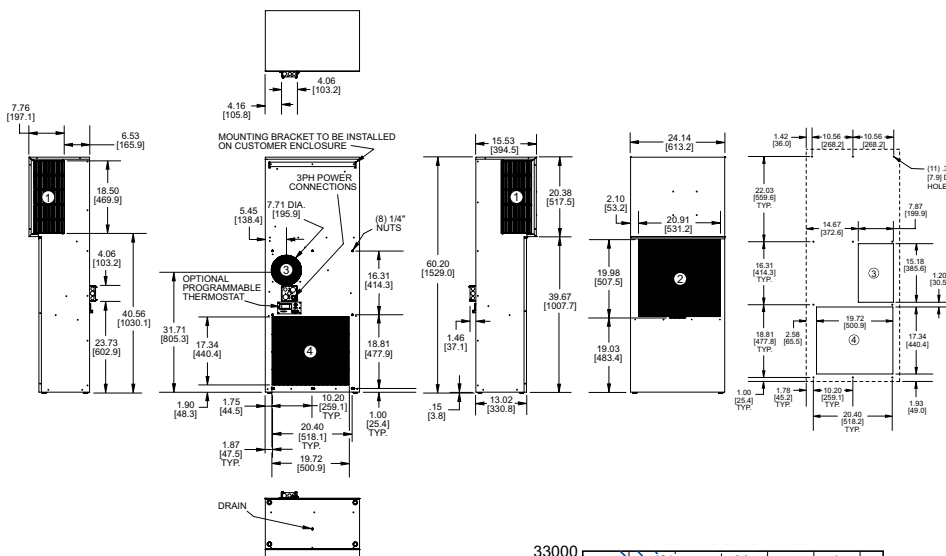

Operation within shaded area not recommended.

DP 60 Series (26,000 BTU/H)

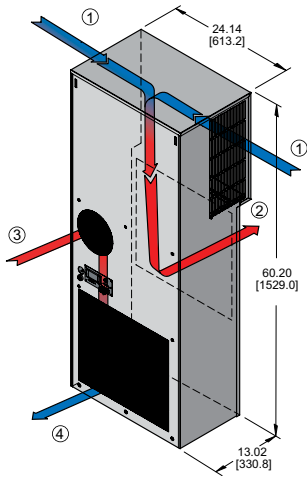

- ① FILTERED CONDENSER AIR INLET (Ambient Air In)
- ② CONDENSER OUTLET (Warm Ambient Air Out)
- ③ WARM AIR RETURN FROM ENCLOSURE
- ④ COOL AIR OUTLET TO ENCLOSURE

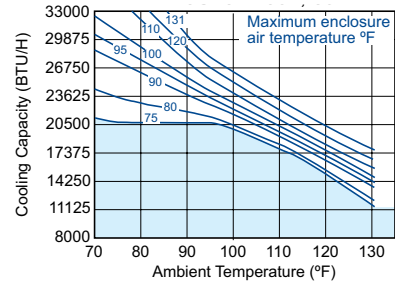
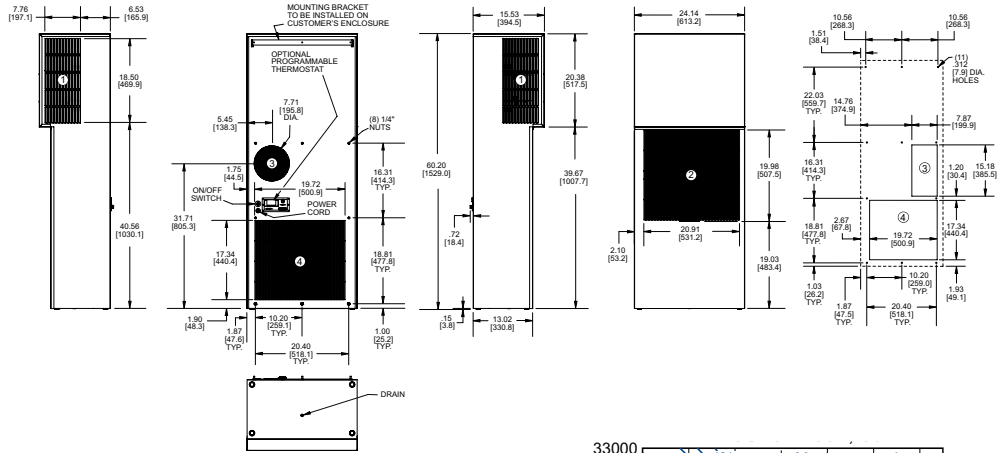



Industry Standards
NEMA 3R, 4, 4X, & 12
UL50



FEATURES-SPECIFICATIONS

The SlimKool Series indoor/outdoor Air Conditioners can be mounted on the exterior of shallow electrical enclosures common in the industry today. The SlimKool Series consists of compact models with a standard width of 11.75 inches, and a standard depth of 15.1 inches, with heights ranging from 28 to 43 inches. These models offer capacities from 4,000

to 11,000 BTU/H, and can operate in ambient temperatures between -20 and 131°F.

- Available in Painted Steel or Stainless Steel (4X Models Only)
- Built-in Condensate Evaporator
- Closed-Loop Cooling
- Compressor Short Cycle Protector

- Epoxy-Coated Evaporator and Condenser Coils
- Internal Corrosion Protection
- Programmable Thermostat
- Programmable Temperature
- Alarm
- Filters
- Zero ODP Refrigerant

SEE PAGES M14-M16 FOR DIAGRAMS AND DIMENSIONAL DRAWINGS

	Overall Size (H x W x D)	NEMA Rating	Volts	HZ	95/95 Rating BTU/H	Running Amps	Ambient Temp Max/Min	Approx Weight (lb)
SP 28 Series (4,000 BTU/H)								
WNA4C4SP28L	28 x 12 x 15	4	115	60	3700	8.4	131/-20	85
W2NA4C4SP28L	28 x 12 x 15	4	230	60	3700	4.1	131/-20	85
W3NA4C4SP28L	28 x 12 x 15	4	480	60	3500	2.1	131/-20	95
WNA4C4SP28LV*	28 x 12 x 15	4X	115	60	3700	8.4	131/-20	85
W2NA4C4SP28LV*	28 x 12 x 15	4X	230	60	3700	4.1	131/-20	85
W3NA4C4SP28LV*	28 x 12 x 15	4X	480	60	3500	2.1	131/-20	95
SP 36 Series (6,000 BTU/H)								
WNA4C6SP36L	36 x 12 x 15	4	115	60	5600	9.6	131/-20	100
W2NA4C6SP36L	36 x 12 x 15	4	230	60	5600	4.6	131/-20	100
W3NA4C6SP36L	36 x 12 x 15	4	480	60	5400	2.2	131/-20	110
WNA4C6SP36LV*	36 x 12 x 15	4X	115	60	5600	9.6	131/-20	100
W2NA4C6SP36LV*	36 x 12 x 15	4X	230	60	5600	4.6	131/-20	100
W3NA4C6SP36LV*	36 x 12 x 15	4X	480	60	5400	2.2	131/-20	110
SP 36 Series (8,000 BTU/H)								
WNA4C8SP36L	36 x 12 x 15	4	115	60	7500	9.6	131/-20	100
W2NA4C8SP36L	36 x 12 x 15	4	230	60	7500	4.6	131/-20	100
W3NA4C8SP36L	36 x 12 x 15	4	480	60	7500	2.7	131/-20	110
WNA4C8SP36LV*	36 x 12 x 15	4X	115	60	7500	9.6	131/-20	100
W2NA4C8SP36LV*	36 x 12 x 15	4X	230	60	7500	4.6	131/-20	100
W3NA4C8SP36LV*	36 x 12 x 15	4X	480	60	7500	2.7	131/-20	110
SP 43 Series (11,000 BTU/H)								
WNA4C11SP43L	43 x 12 x 15	4	115	60	9300	20.0	131/-20	115
W2NA4C11SP43L	43 x 12 x 15	4	230	60	9300	11.0	131/-20	115
W3NA4C11SP43L	43 x 12 x 15	4	480	60	9300	3.5	131/-20	125
WNA4C11SP43LV*	43 x 12 x 15	4X	115	60	9300	20.0	131/-20	115
W2NA4C11SP43LV*	43 x 12 x 15	4X	230	60	9300	11.0	131/-20	115
W3NA4C11SP43LV*	43 x 12 x 15	4X	480	60	9300	3.5	131/-20	125

*STAINLESS STEEL NEMA 4X MODEL

SP 28 480V Series (4,000 BTU/H)

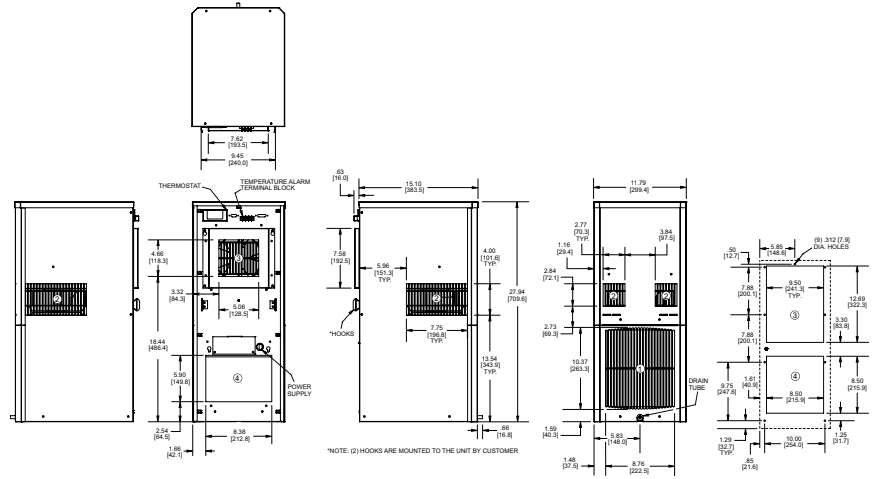
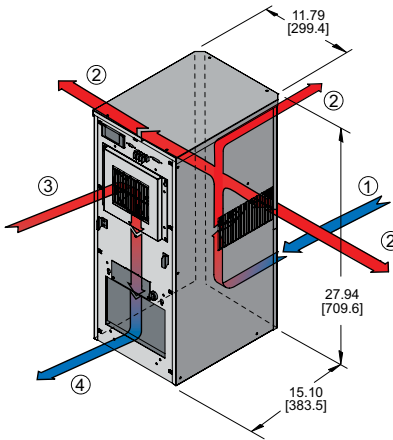

- ① FILTERED CONDENSER AIR INLET (Ambient Air In)
- ② CONDENSER OUTLET (Warm Ambient Air Out)
- ③ WARM AIR RETURN FROM ENCLOSURE
- ④ COOL AIR OUTLET TO ENCLOSURE

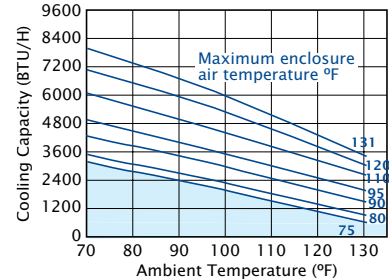

SP 28 Series (4,000 BTU/H)

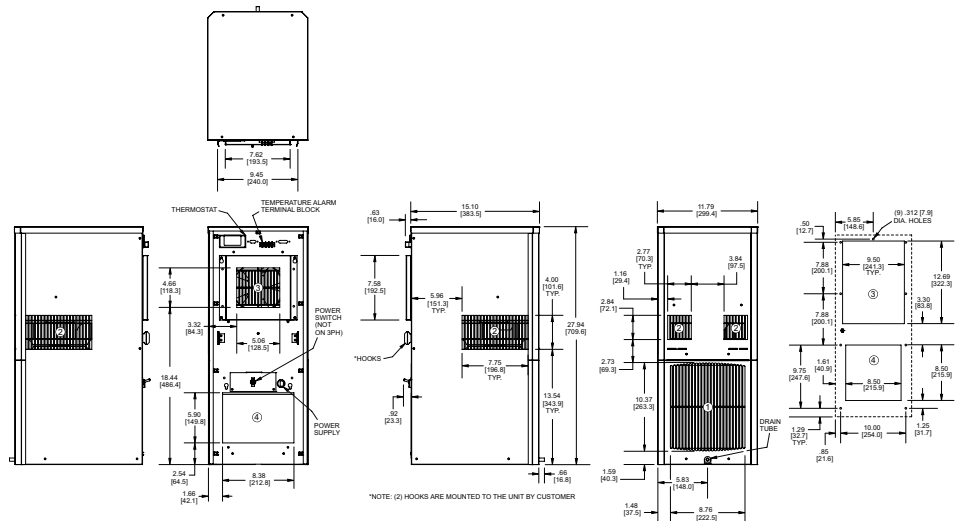
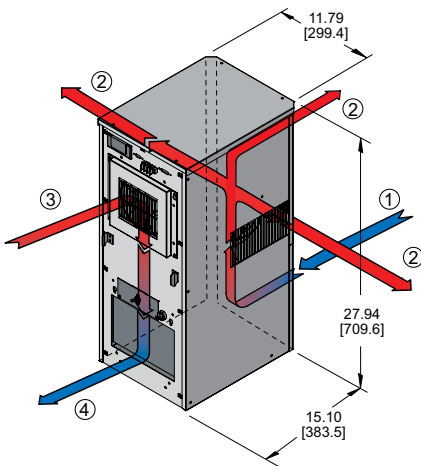

- ① FILTERED CONDENSER AIR INLET (Ambient Air In)
- ② CONDENSER OUTLET (Warm Ambient Air Out)
- ③ WARM AIR RETURN FROM ENCLOSURE
- ④ COOL AIR OUTLET TO ENCLOSURE

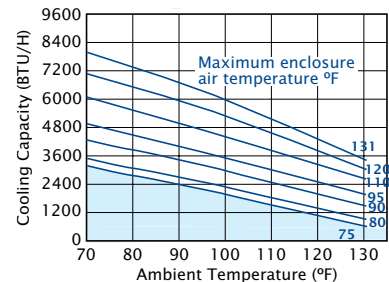

SP 36 480V Series (6,000 and 8,000 BTU/H)

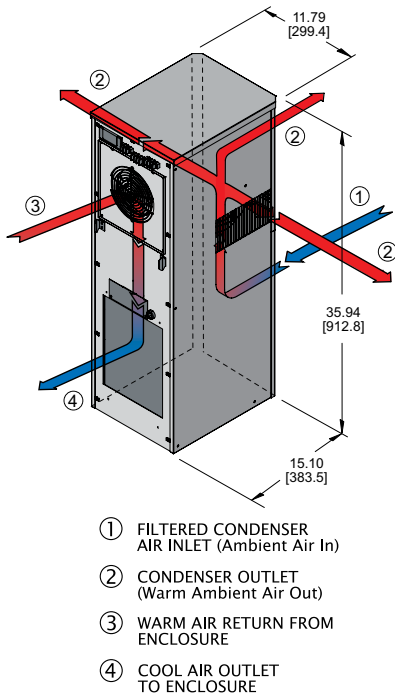

- ① FILTERED CONDENSER AIR INLET (Ambient Air In)
- ② CONDENSER OUTLET (Warm Ambient Air Out)
- ③ WARM AIR RETURN FROM ENCLOSURE
- ④ COOL AIR OUTLET TO ENCLOSURE

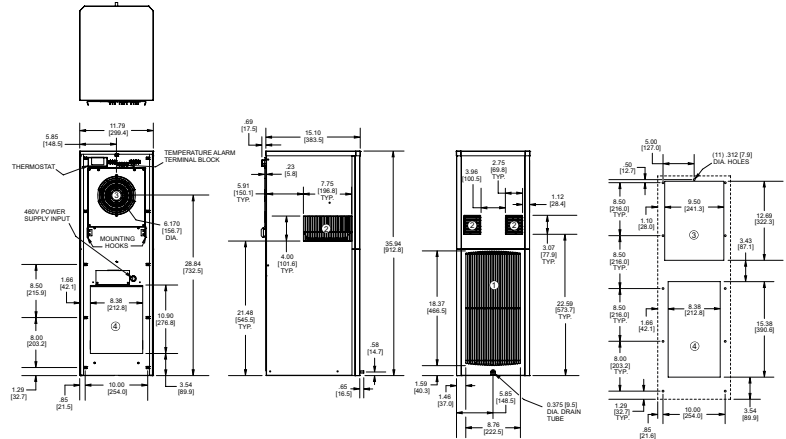
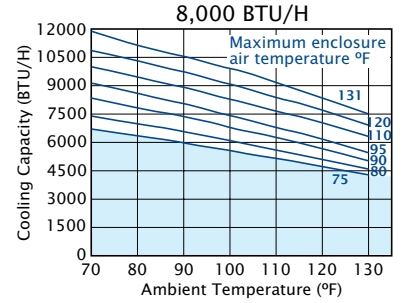
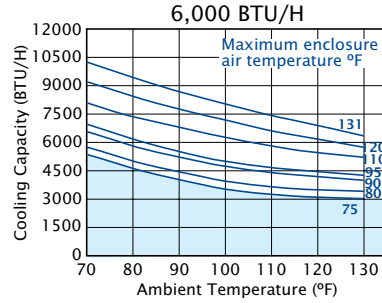

SP 36 Series (6,000 and 8,000 BTU/H)

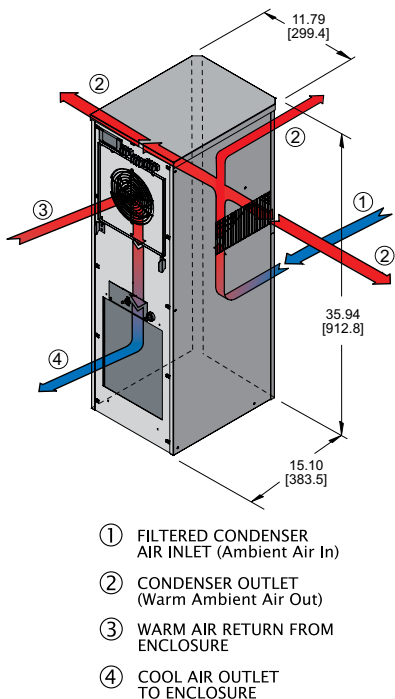

- ① FILTERED CONDENSER AIR INLET (Ambient Air In)
- ② CONDENSER OUTLET (Warm Ambient Air Out)
- ③ WARM AIR RETURN FROM ENCLOSURE
- ④ COOL AIR OUTLET TO ENCLOSURE

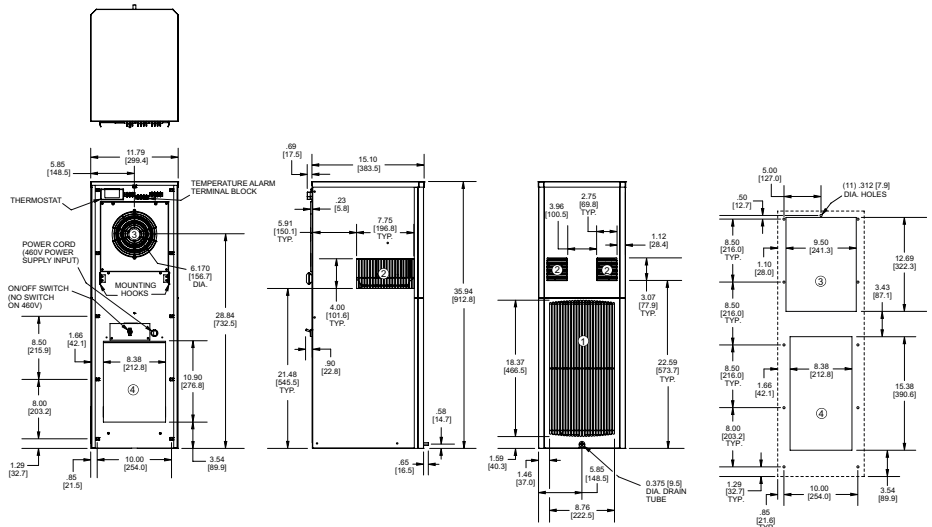
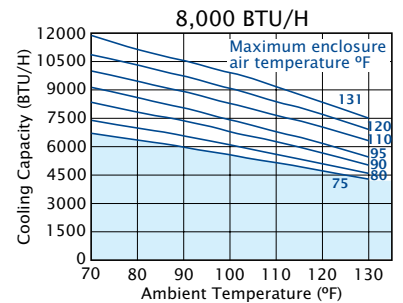
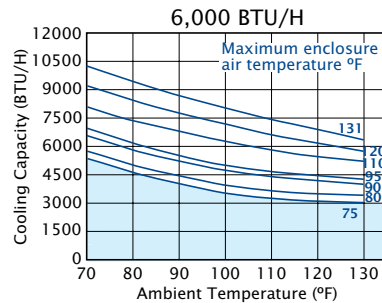

SP 43 480V Series (11,000 BTU/H)

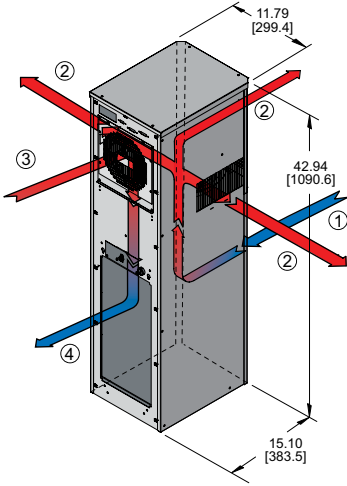

- ① FILTERED CONDENSER AIR INLET (Ambient Air In)
- ② CONDENSER OUTLET (Warm Ambient Air Out)
- ③ WARM AIR RETURN FROM ENCLOSURE
- ④ COOL AIR OUTLET TO ENCLOSURE

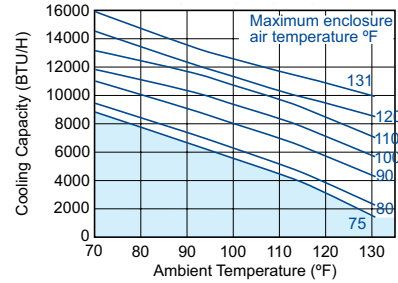
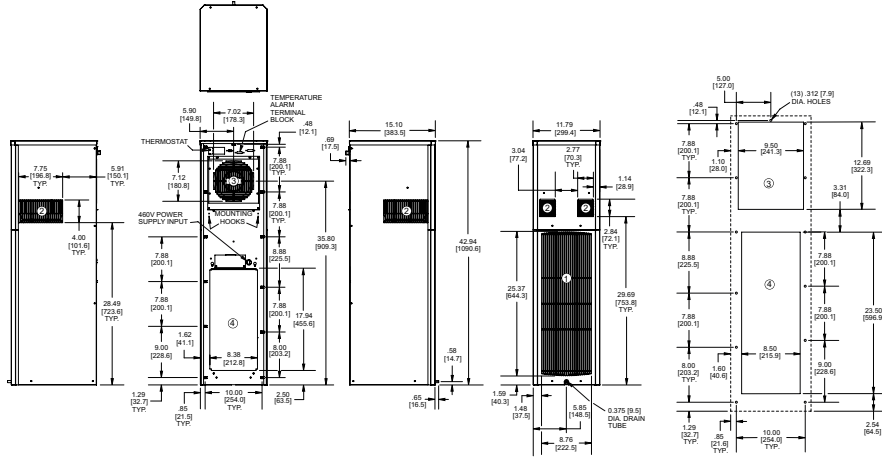

SP 43 Series (11,000 BTU/H)

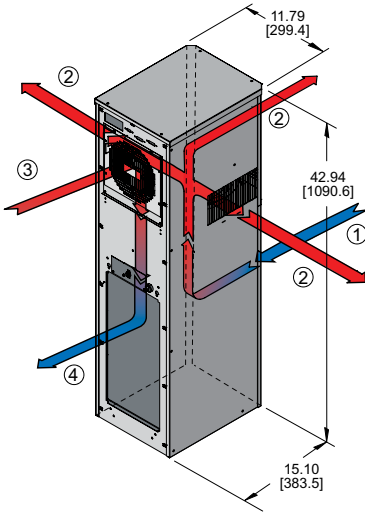

- ① FILTERED CONDENSER AIR INLET (Ambient Air In)
- ② CONDENSER OUTLET (Warm Ambient Air Out)
- ③ WARM AIR RETURN FROM ENCLOSURE
- ④ COOL AIR OUTLET TO ENCLOSURE

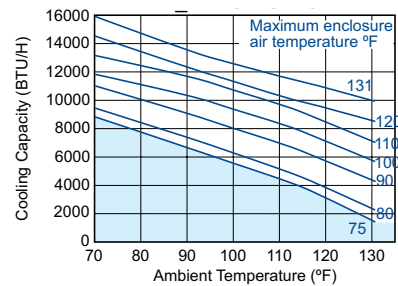
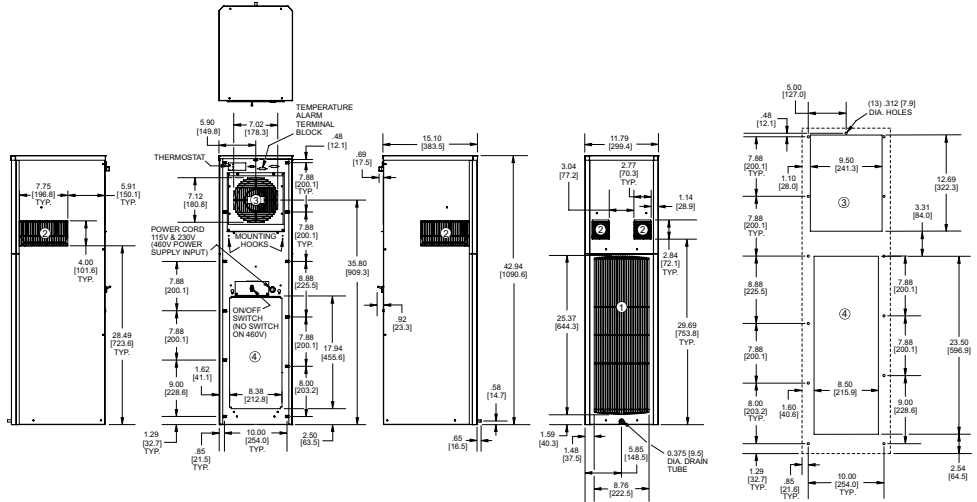



**NEMA
TYPE 12
MAINTAINED**

- ① FILTERED CONDENSER AIR INLET (Ambient Air In)
- ② CONDENSER OUTLET (Warm Ambient Air Out)
- ③ WARM AIR RETURN FROM ENCLOSURE
- ④ COOL AIR OUTLET TO ENCLOSURE

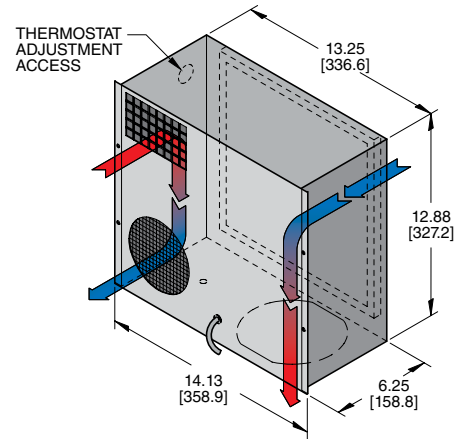

FEATURES-SPECIFICATIONS

Standard Features

- Ball-bearing Motors
- CFC-Free Refrigerant
- EMI/RFI Suppressor
- Low Temperature Control Thermostat
- NEMA 12 Rating Maintained (UL50)
- UL/CUL Listed
- Gray Powder Finish

Accessories and Options

- Adapter Plate for rack mounting
- Compressor Heater
- Condensate Evaporator
- Cooling Effect Detector
- Filter Recoating Adhesive
- Filters for replacement
- Internal corrosion protection
- Lifting Eyes

- Low Ambient Kit and Compressor Heater
- Mounting Hinge
- Short Cycle Protector
- Special materials or finishes
- Special motors, line cords, or connectors
- Stainless or Aluminum Cabinet
- Weather Protection Kit

MICRO-MINI SERIES AIR-COOLED PANEL-MOUNTED AIR CONDITIONERS

Model	Rate Capacity (btu/h)	95/95 Rating (btu/h)	Ambient Temp. °F Max./Min.	Volts	Hz	Running Amps	Approximate Weight (lbs.)
WA4C10MML	1000	600	125/50	115/100	60/50	4.5	43
W2A4C10MML	1000	600	125/50	230/200	60/50	2.3	43

MOUNTING PLAN

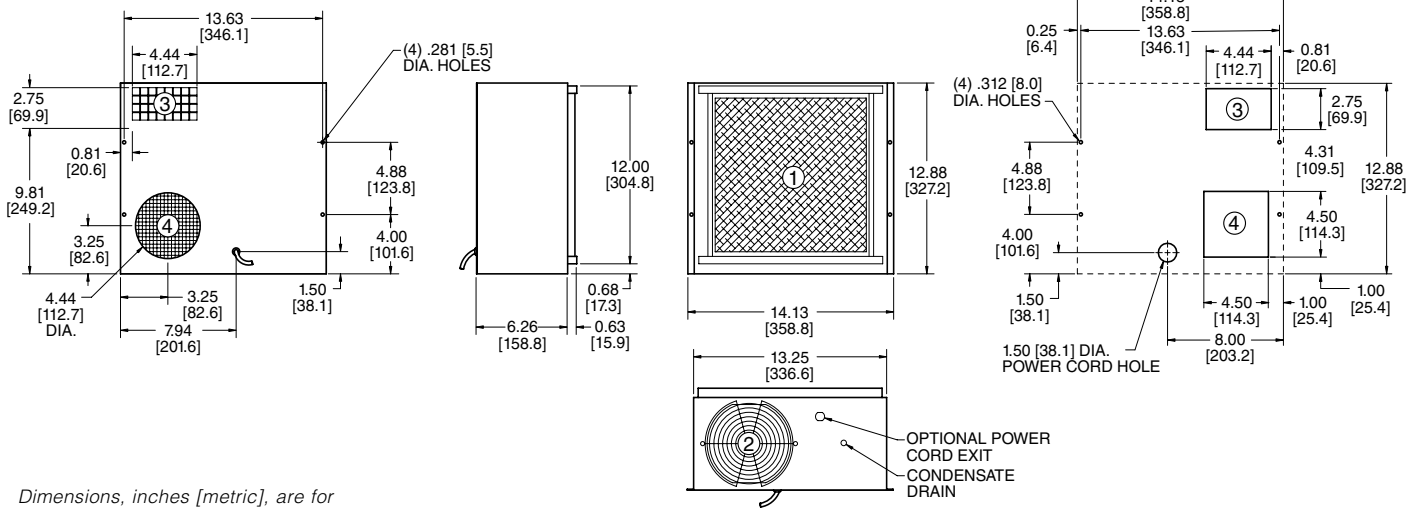

Dimensions, inches [metric], are for reference only and subject to change.



Standard Features

- Built-in Condensate Evaporator
- CFC-Free Refrigerant
- EMI/RFI Suppressor
- Low Temperature Control Thermostat
- UL/CUL Listed
- Gray Powder Finish

Accessories and Options

- Cooling Effect Detector
- Enclosure Heater
- Filter Recoating Adhesive

- Filters for replacement
- Internal corrosion protection
- Lifting Eyes
- Low Airflow Detector
- Low Ambient Kit
- Short Cycle Protector
- Special materials or finishes
- Special motors, linecords or protectors
- Stainless or Aluminum Cabinet

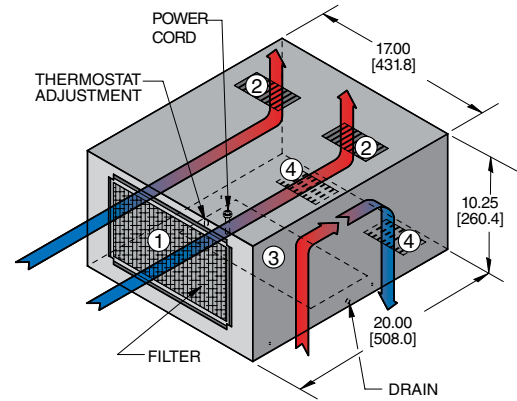

- ① FILTERED CONDENSER AIR INLET (Ambient Air In)
- ② CONDENSER OUTLET (Warm Ambient Air Out)
- ③ WARM AIR RETURN FROM ENCLOSURE
- ④ COOL AIR OUTLET TO ENCLOSURE

PERFORMANCE CHART

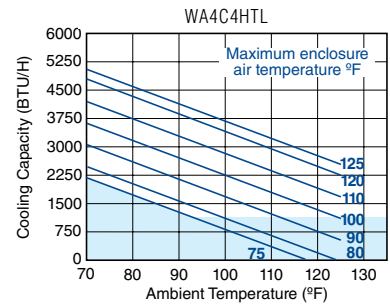

Operation within shaded areas not recommended.

COMPACT SERIES AIR-COOLED TOP-MOUNTED AIR CONDITIONERS

Model	Rate Capacity (btu/h)	95/95 Rating (btu/h)	Ambient Temp. °F Max./Min.	Volts	Hz	Running Amps	Approximate Weight (lbs.)
WA4C4HTR	4000	2200	125/50	115/100	60/50	13.1	85
W2A4C4HTR	4000	2200	115/50	230/200	60/50	5.9	85

MOUNTING PLAN

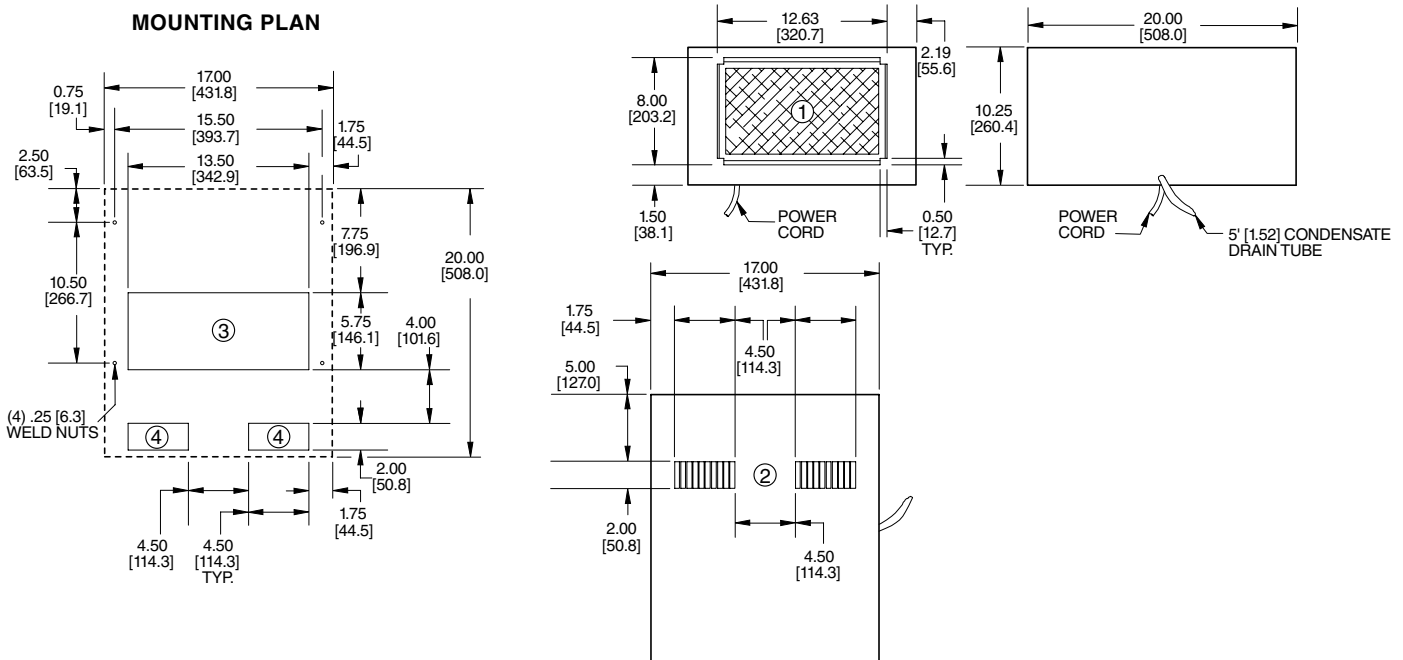



NEMA 4/4X



NEMA 12

Industry Standards

UL Listed
NEMA 12, 4 or 4X



FEATURES-SPECIFICATIONS

Applications

Compressed air cooling is used where conventional enclosure cooling (air conditioners or heat exchangers) is not possible. Example: Small to medium size enclosures; nonmetallic enclosures; areas where the size of cooling devices is restricted.

Features

- Suitable for harsh environments
- Small physical size
- Creates cool air without refrigerants (no CFC's, HFC's)
- Exceptionally reliable—no moving parts
- Virtually no maintenance

Requirements

- Clean, dry, oil-free compressed air (100 PSIG/70°F or below) required

to achieve published BTU/hr. ratings. Lower pressures and higher temperatures will reduce BTU/hr. ratings

- A 5 micron water and particulate removal filter must be installed prior to operating any Vortex Cooler (included in kits)
- An oil removable filter can be installed between the 5 micron filter and the Vortex cooler if oil is present in the compressed air line
- Mounting holes:
 - NEMA 12 kits — (1) 1-3/32" (28mm) or 3/4" knockout hole for cooling tube and (1) 11/16" hole for thermostat
 - NEMA 4 & NEMA 4X kits — (1) 1-5/16" (49mm) or 1-1/2" knockout hole for cooling tube and (2) #8 holes for thermostat

Kit Includes the Following

- Vortex Cooling Tube
- Solenoid Valve 120V 60Hz – 110V 50 Hz (230V available)
- 5 micron water and particulate removal filter
- Ducting Kit
- Thermostat

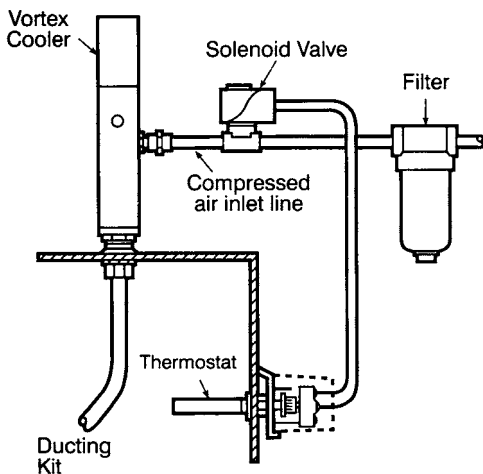

How Enclosure Coolers Create Cold Air

Vortex Coolers are powered by a vortex tube – a unique device that creates a vortex from compressed air and separates it into hot and cold airstreams. Here's how it works. The vortex tube's cylindrical generator causes the input compressed air to rotate, reaching speeds up to 1,000,000 rpm as it is forced down the inner walls of the hot, or longer end of the vortex tube. At the end of the hot tube, a small portion of this air exits through a needle valve as hot air exhaust. The remaining air is forced back through the center of the incoming air stream at a slower speed. The heat in the slower moving air is transferred to the faster moving incoming air. This super-cooled air flows through the center of the generator and exits through the cold air exhaust port.

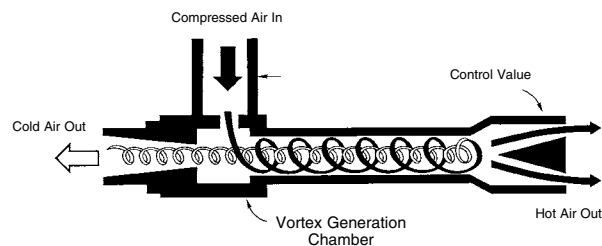

VORTEX COOLERS

Catalog Number	Capacity		Air Consumption			Tube Surface Temp at BTU	Thermostat Mounting	NEMA Type	UL Type	Cooling Tube Materials
	BTU/H	K CAL/H	SCFM	SLPM	Thermostat (Factory Set)					
W750400	400	101	8	227	90°F ± 2°	150°F	External	12	12	Aluminum
W740900	900	225	15	425	90°F ± 2°	150°F	External	12	12	Aluminum
W7901500	1500	378	25	708	90°F ± 2°	150°F	External	12	12	Aluminum
W7971700	1700	425	25	708	90°F ± 2°	150°F	Internal	4	4	Aluminum
W797SS1700	1700	425	25	708	90°F ± 2°	150°F	Internal	4X	4X	Stainless Steel

ACCESSORIES

Catalog Number	Filter and Type Size
W38OILFILTER	Auto-drain oil removal filter, 3/8" NPT (F), rated to 25 SCFM/708 SLPM
W12OILFILTER	Auto-drain oil removal filter, 1/2" NPT (F), rated to 50 SCFM/1415 SLPM

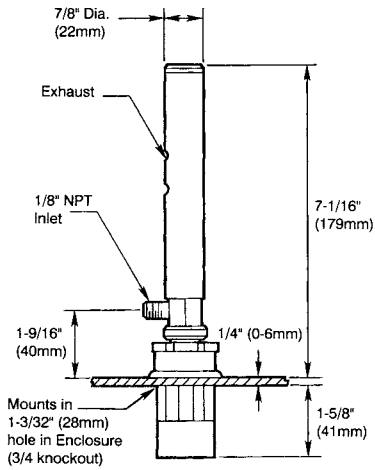

Model W750400

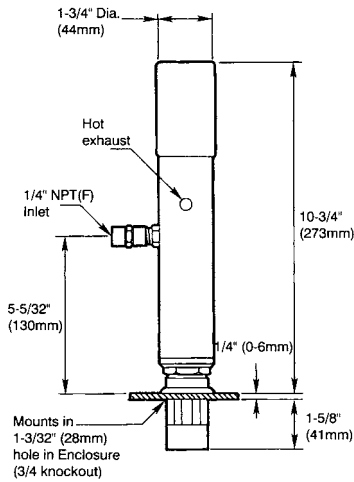

Model W740900 & W7901500

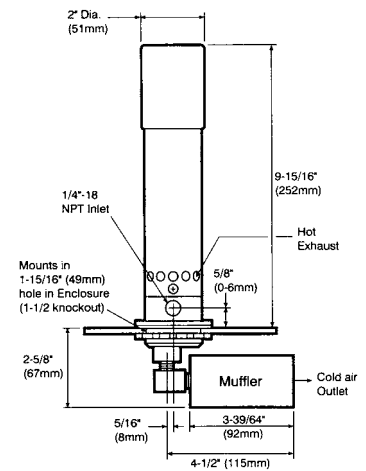

Model W7971700 & W797SS1700

Note: Thermostats for Models W750400, W740900 and W7901500 mounts in an 11/16" (18mm) diameter hole.



FBF1010115V

Industry Standards

UL Recognized Component
cUL Recognized Component
CE Recognized

FEATURES-SPECIFICATIONS

Applications

Used for enclosure cooling in low static pressure applications

Features

- High airflow, low noise operation
- Reliable cooling is achieved particularly in areas with minimum space requirements
- The cooling system incorporates the filtered fan boxes as its air inlet, while the exhaust grille is the air outlet

- The washable exhaust grille and aluminum filter are easily accessible and can be removed for cleaning
- Available in 115 VAC or 230 VAC 50/60 HZ versions
- Steel construction
- Attractive, aesthetically appealing grille design
- All models can pressurize or exhaust
- Included aluminum filter is coated with adhesive baffle surfaces for dust and dirt collection. The filter can be recoated after cleaning for optimum performance

Note: One grille and filter are included with each fan package. Normally, an additional exhaust grille and filter is required for each installation and must be ordered separately.

Accessories

- Exhaust Grille and Filters (see page M22)

FILTERED BOX FANS

Catalog Number	Free-Flow Air Delivery (CFM)	Rated Voltage	Nominal (RPM)	Watts
FBF44115V	117	115	0.24	20
FBF44230V	117	230	0.12	21
FBF66115V	239	115	0.23	27
FBF66230V	239	230	0.11	26
FBF1010115V	630	115	0.62	68
FBF1010230V	630	230	0.30	63

FBF44 (115V, 230V)

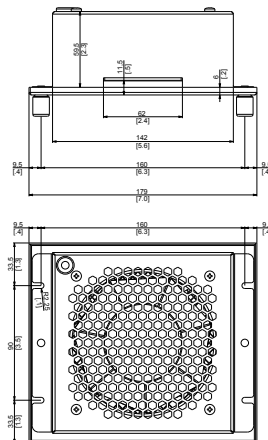

FBF66 (115V - 230V)

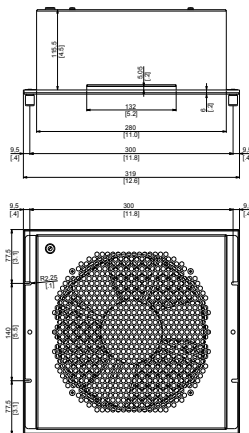

FBF1010 (115V -230V)

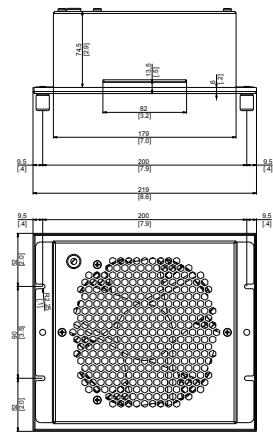



FRFBF44, FRFBF66, FRFBF1010

Industry Standards

UL Recognized Component
 cUL Recognized Component
 CE Recognized

FEATURES-SPECIFICATIONS

Features

- Mounting holes on filter brackets align with Exhaust Grille for easy mouting
- Filters are designed to mount behind Exhuast Grille
- Kit includes washable Exhaust Grille, aluminum filter, mounting brackets, and all necessary hardware for installation

EXHAUST GRILLE W/FILTER KIT

Catalog Number	For use with
EGFBF44	FBF44115V & FBF44230V
EGFBF66	FBF66115V & FBF66230V
EGFBF1010	FBF1010115V & FBF1010230V

REPLACEMENT ALUMINUM FILTER ONLY

Catalog Number	For use with
FRFB44	FBF44115V & FBF44230V
FRFB66	FBF66115V & FBF66230V
FRFB1010	FBF1010115V & FBF1010230V



WA4AXFN

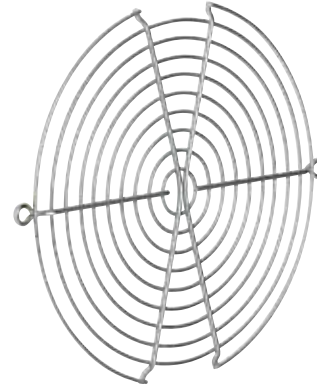

WAGARD6

FEATURES-SPECIFICATIONS

MUFFIN FANS & FINGER GUARDS

Applications

Designed for use in enclosures where space is limited and reliable cooling is required.

Features

- Fan furnished standard with 24" lead wire. 90 degree plug attached
- Black color
- Impeller and frame are glass reinforced thermoplastic, UL94-VO
- Die cast aluminum housing

- Finger guards are welded electroplated nickel chrome steel wire. Guards withstand 200 lbs. separation force to meet UL, CSA standards
- One finger guard and all mounting hardware is provided. Additional finger guards can be mounted on either side for maximum safety

WAXFN SERIES MUFFIN FANS & WAGARD SERIES FINGER GUARDS

Catalog Number		Voltage Rating	Rated Input (Watts)	Freq. (Hz)	Rated Speed (RPM)	Noise Level	Maximum Air flow		Maximum Static Pressure/H2O	Dimensions HxWxD
Fan	Fan Guard						(M3/MIN)	CFM		
WA4AXFN	WAGARD4	115	17/15	50/60	2500/3000	37 ± 2	2.5/3.1	88/110	5.8/7.0	4.71x4.71x1.50 (120x120x38)
WA4AXFN2	WAGARD4	230	17/15	50/60	3500/3000	37 ± 2	2.5/3.1	88/110	5.8/7.0	4.71x4.71x1.50 (120x120x38)
WA6AXFN	WAGARD6	115	26/35	50/60	2800/3500	46 ± 2	5.4/6.6	190/235	5.4/6.6	6.77x6.77x2.01 (172x172x51)
WA6AXFN2	WAGARD6	230	26/35	50/60	2800/3500	46 ± 2	5.4/6.6	190/235	5.4/6.6	6.77x6.77x2.01 (172x172x51)
WA10AXFN	WAGARD10	115	35	50/60	1650	55	—	547	10	10.00x10.00x3.50 (254x254x89)
WA10AXFN2	WAGARD10	230	33	50/60	1650	55	—	547	10	10.00x10.00x3.50 (254x254x89)

ENVIRONMENTAL CONTROLS
WAVK, WAVK-SS & WAFLT LOUVER PLATE KITS & FILTER KITS



WAVK0303SSA



WAFLT33

FEATURES-SPECIFICATIONS

LOUVER PLATE KITS

Description

Designed to provide ventilation or cooling in enclosures where excessive moisture or excessive internal heat is a problem. These kits are fabricated from carbon steel or 316L stainless steel and include all hardware for mounting. Kits are easily field installed by making a cutout of the proper size and attaching the louver plate in place. Finish is ANSI 61 gray polyester powder finish. Filter kit must be ordered separately.

FILTER KITS FOR LOUVER PLATES KITS

Description

Designed for use with Louver Plate Kit. Mounting holes on filter brackets align with mounting holes on louver kits. Aluminum filters are good for stopping dust and dirt from penetrating the enclosures. Filters are designed to mount behind louver kits. Kit consists of aluminum filter, brackets and all necessary hardware for installation. Louver kit must be ordered separately.

WAVK SERIES LOUVER PLATE KIT AND WAFLT SERIES FILTER KITS FOR LOUVER PLATES

Louver Kit Painted	Catalog Number		Number of Louvers	Number of Louver rows	Louver Length	A	B	L	M	P	R	S
	Louver Kit 316 SS	Filter Kit										
WAVK0203	WAVK0203SSA	—	3	1	2.00 (51)	3.25 (83)	3.25 (83)	2.00 (51)	2.00 (51)	2.50 (64)	2.50 (64)	—
WAVK0303	WAVK0303SSA	WAFLT33	3	1	3.00 (76)	3.87 (98)	4.50 (114)	2.62 (67)	3.25 (83)	3.12 (79)	3.75 (95)	—
WAVK0304	WAVK0304SSA	WAFLT34	4	1	3.00 (76)	4.75 (121)	4.50 (114)	3.50 (89)	3.25 (83)	4.00 (102)	3.75 (95)	—
WAVK0404	WAVK0404SSA	WAFLT44	4	1	4.00 (102)	5.62 (143)	5.50 (140)	4.37 (111)	4.25 (108)	4.87 (124)	4.75 (121)	—
WAVK0604	WAVK0604SSA	WAFLT64	8	2	3.00 (76)	5.62 (143)	7.50 (191)	4.37 (111)	6.25 (159)	4.87 (124)	6.75 (171)	—
WAVK0606	WAVK0606SSA	WAFLT66	12	2	3.00 (76)	7.87 (200)	7.50 (191)	6.62 (168)	6.25 (159)	7.12 (181)	6.75 (171)	3.56 (90)
WAVK0806	WAVK0806SSA	WAFLT86	12	2	4.00 (102)	8.18 (208)	9.50 (241)	6.93 (176)	8.25 (210)	7.43 (189)	8.75 (222)	3.71 (94)
WAVK0808	WAVK0808SSA	WAFLT88	16	2	4.00 (102)	10.56 (268)	9.50 (241)	9.31 (236)	8.25 (210)	9.81 (249)	8.75 (222)	4.90 (124)
WAVK0812	WAVK0812SSA	WAFLT812	24	2	4.00 (102)	15.31 (389)	9.50 (241)	14.06 (357)	8.25 (210)	14.56 (370)	8.75 (222)	7.28 (185)

Note: Center holes (dimension "S") are not needed on any filter kits. Only 6 x 6 and larger louver kits require center holes.

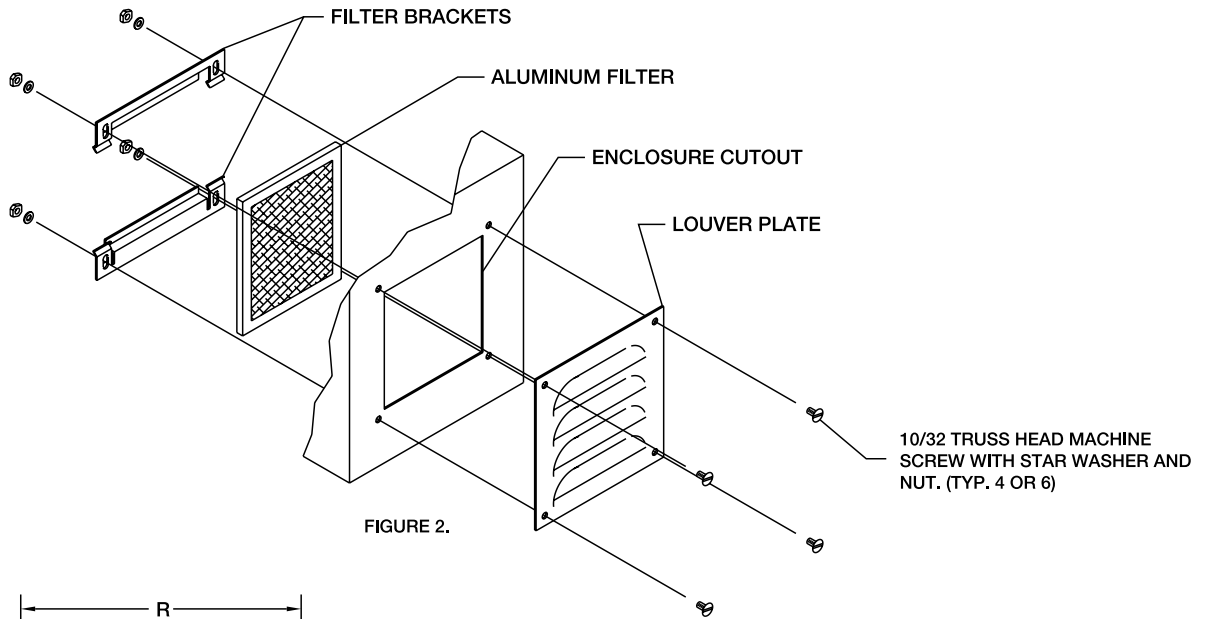

FIGURE 2.

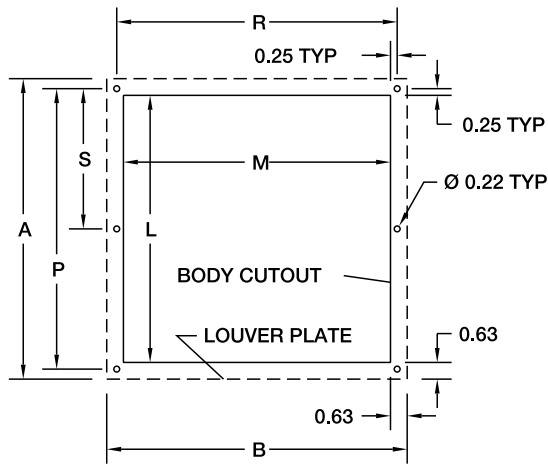

FIGURE 1

Notes:

Installation Instructions

1. Make sure the proper louver kit and/or filter kit has been ordered.
2. Locate and mark holes and cutout as shown in figure 1.
3. Drill holes using a 7/32" drill bit making sure there are no electrical wires or internal components in the way.
4. Assemble louver kits and/or filter kits as shown in figure 2.

Note: After installation is complete, make sure louver and filter kits do not interfere with any internal or external equipment.



RH115230V100W



RHPC115230V25W

Industry Standards

- UL Recognized Component
- cUL Recognized Component
- CE Recognized

FEATURES-SPECIFICATIONS

Applications

Designed to provide enclosed electronic, pneumatic, hydraulic and mechanical equipment with protection from low temperatures, condensation and corrosion

Features

- Heater maintains a stable temperature within the enclosure, allowing critical components to perform with consistent reliability

- Heaters include DIN rail clip 1.37"
- Connection is silicon cable, 2 x 20 AWG, 15.75" length on 25W and 50W units, 2 screw terminal block for 14 AWG on 75W, 100W and 150W units
- RHPC heaters are supplied with a heat guard to protect the heating element

- CAUTION—do not mount on wooden structures, avoid placement near heat sensitive components

Accessories

- Thermostats (see pages M31-M32)

RH/RHPC SERIES RADIANT HEATERS

Catalog Number	Watts	Rated Voltage	Dimensions HxWxD
RH115230V25W	25	110-240	3.94x1.57x1.57 (100x40x40)
RH115230V50W	50	110-240	3.94x1.57x1.57 (100x40x40)
RH115230V75W	75	110-240	5.51x2.32x2.40 (140x59x61)
RH115230V100W	100	110-240	5.51x2.32x2.40 (140x59x61)
RH115230V150W	150	110-240	8.66x2.32x2.40 (220x59x61)
RHPC115230V25W	25	110-240	4.92x1.61x1.61 (125x41x41)
RHPC115230V50W	50	110-240	4.92x1.61x1.61 (125x41x41)
RHPC115230V75W	75	110-240	5.51x2.76x2.48 (140x70x63)
RHPC115230V100W	100	110-240	5.51x2.76x2.48 (140x70x63)
RHPC115230V150W	150	110-240	8.66x2.76x2.48 (225x70x63)

RHPC SERIES 25&50W

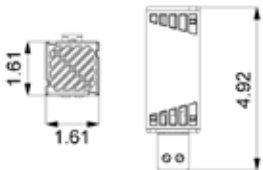

RH SERIES 25&50W

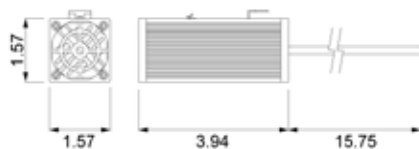

RHPC SERIES 150W

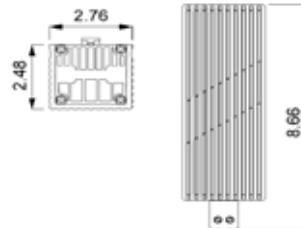

RH SERIES 150W

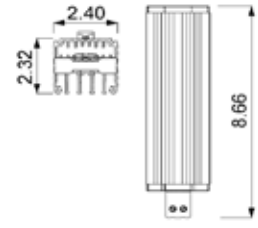

RHPC SERIES 75&100W

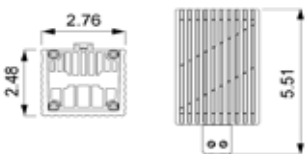

RH SERIES 75&100W

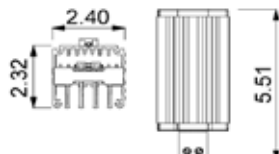



WHVLO31100120

Industry Standards

- UL Recognized Component
- cUL Recognized Component
- CE Recognized

FEATURES-SPECIFICATIONS

Applications

Used when larger heating capacities or internal forced air circulation is required and space is limited.

Features

- Compact design to prevent condensation and maintain a minimum temperature inside of the enclosure

- Cartridge heater heating element
- 50,000 hour life expectancy at 77°F ambient temperature
- Connection: 5 pole terminal for max. 14 AWG
- Easily installed by clip mounting on 35mm DIN rails
- Protection class 1 (tested for grounding at 1,500 V)
- Heater comes fully assembled

with fan

- **CAUTION**—Do not mount on wooden structures. Avoid placement near heat-sensitive components. Note that fan must be used in conjunction with heating element

Accessories

- Thermostats (see pages M31-M32)

WHVL SERIES FAN HEATERS

Catalog Number	Rated Voltage	Watts	Operating Current (AMPS)	Maximum Temperature With Fan	Dimensions HxWxD
WHVLO31100120	120	100	0.89	250°F (120°C)	1.85x3.15x4.41(47x80x112)
WHVLO31150120	120	150	1.30	320°F (160°C)	1.85x3.15x4.41(47x80x112)
WHVLO31200120	120	200	1.79	250°F (120°C)	1.85x4.68x5.94(47x119x151)
WHVLO31300120	120	300	2.62	320°F (160°C)	1.85x4.68x5.94(47x119x151)
WHVLO31400120	120	400	3.45	360°F (180°C)	1.85x4.68x5.94(47x119x151)
WHVLO31400230	230	400	3.45	360°F (180°C)	1.85x4.68x5.94(47x119x151)

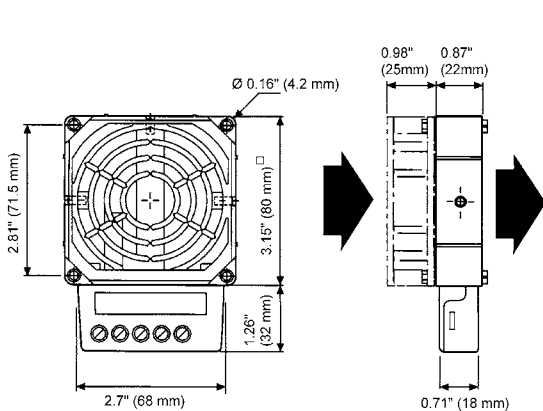

100 & 150W Heaters

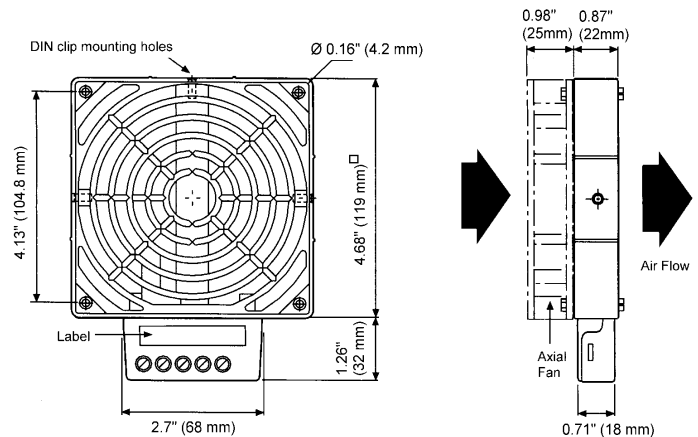

200, 300 & 400W Heaters



FH125W/200W



FH400W/800W

Industry Standards

- UL Recognized Component
- cUL Recognized Component
- CE Recognized

FEATURES-SPECIFICATIONS

Applications

Designed to prevent condensation and to maintain a minimum temperature inside of an enclosure

Features

- Built in adjustable thermostat

- Aluminum housing
- Includes an auto fan control switch to prolong motor life
- Light weight design allows for easy panel mounting
- Pilot light for “heat on” indication

- Integrated overheat protection
- CAUTION— do not mount on wooden structures, avoid placement near heat sensitive components

FH SERIES FAN HEATERS

Catalog Number	Rated Voltage	Watts	Thermostat Range	Fan	Temperature Scale	Dimensions HxWxD
FH115V125W	115	125	-4 to 104 deg F	16 CFM	Fahrenheit	5.39x4.09x4.61 (137x104x117)
FH230V125W	230	125	-4 to 104 deg F	16 CFM	Fahrenheit	5.39x4.09x4.61 (137x104x117)
FH115V200W	115	200	-4 to 104 deg F	16 CFM	Fahrenheit	5.39x4.09x4.61 (137x104x117)
FH230V200W	230	200	-4 to 104 deg F	16 CFM	Fahrenheit	5.39x4.09x4.61 (137x104x117)
FH115V400W	115	400	-4 to 104 deg F	26 CFM	Fahrenheit	7.48x4.09x4.61 (190x104x117)
FH230V400W	230	400	-4 to 104 deg F	26 CFM	Fahrenheit	7.48x4.09x4.61 (190x104x117)
FH115V800W	120	800	-4 to 104 deg F	26 CFM	Fahrenheit	7.48x4.09x4.61 (190x104x117)
FH230V800W	230	800	-4 to 104 deg F	26 CFM	Fahrenheit	7.48x4.09x4.61 (190x104x117)

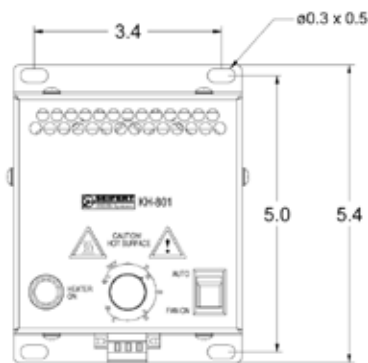
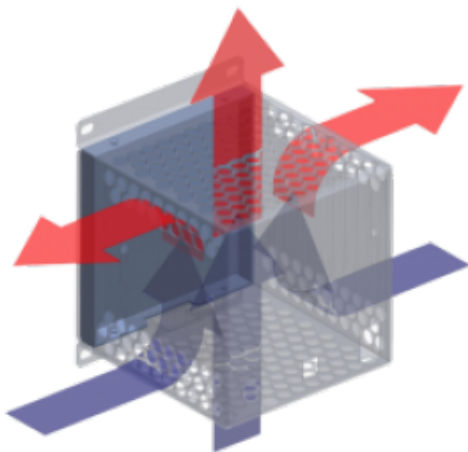

FH115V125W - FH230V200W

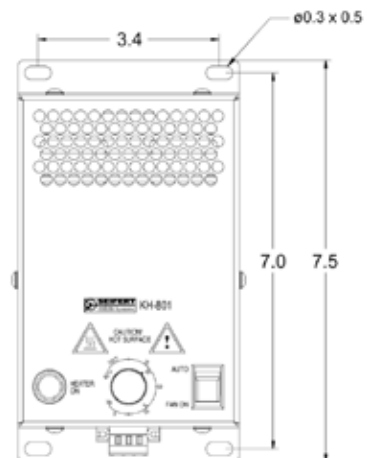

FH115V400W - FH230V800W



FH250W



FH400W/500W



FH750W

Industry Standards

- UL Recognized Component
- cUL Recognized Component
- CE Recognized
- VDE Approval

FEATURES-SPECIFICATIONS

Applications

This fan assisted register heater is designed for when larger heating capacities or internal forced air circulation is required. The heater prevents condensation and maintains a minimum temperature inside of an enclosure.

Features

- Supplied with DIN rail clip installed
- Easily installed on 35mm DIN rail
- Connection is 3 screw terminal for 14 AWG
- CAUTION— do not mount on wooden structures, avoid placement near heat sensitive components

Accessories

- Thermostats (see pages M31-M32)

FH SERIES FAN HEATERS

Catalog Number	Rated Voltage	Watts	Starting Amps	Circulation Power	Dimensions HxWxD
FH115V250W	115	250	2.4	20 CFM	5.30x4.40x3.20 (135x112x81)
FH230V250W	230	250	1.2	20 CFM	5.30x4.40x3.20 (135x112x81)
FH115V400W20	115	400	3.8	20 CFM	6.50x4.40x3.20 (165x112x81)
FH230V400W20	230	400	1.9	20 CFM	6.50x4.40x3.20 (165x112x81)
FH115V500W	115	500	4.8	20 CFM	6.50x4.40x3.20 (165x112x81)
FH230V500W	230	500	2.4	20 CFM	6.50x4.40x3.20 (165x112x81)
FH115V750W	115	750	7.2	26 CFM	8.80x4.40x3.20 (224x112x81)
FH230V750W	230	750	3.6	26 CFM	8.80x4.40x3.20 (224x112x81)

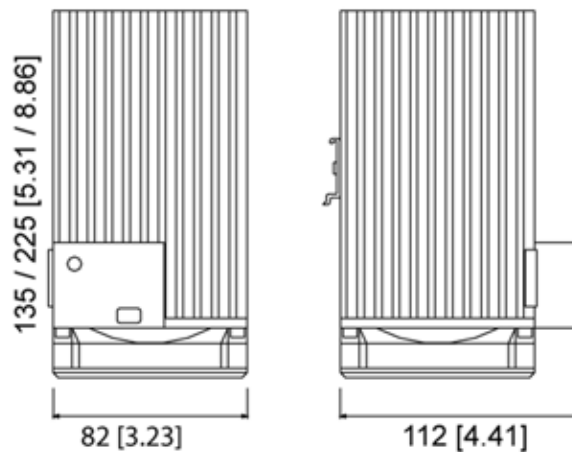

FH SERIES with height variance
(5.30, 6.50, & 8.80 inches)

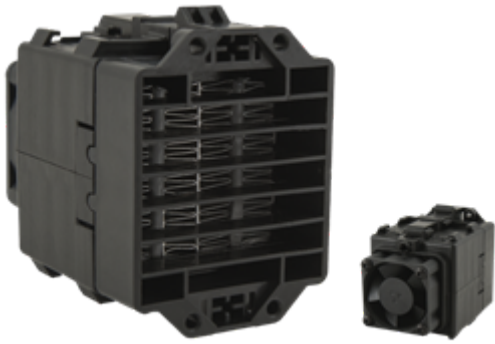

FH115230V300W

Industry Standards
 UL Recognized Component
 cUL Recognized Component
 CE Recognized
 VDE Approval

FEATURES-SPECIFICATIONS

Applications

- Designed for when larger heating capacities or internal forced air circulation is required
- Prevents condensation and maintains a minimum temperature inside of an enclosure

Features

- The small size makes it a cost effective solution for temperature control
- Delivery includes DIN rail clips and screw mount capabilities
- DIN rail clips for 15 and 35mm

- CAUTION— do not mount on wooden structures, avoid placement near heat sensitive components

Accessories

- Thermostats (see pages M31-M32)

FH SERIES FAN HEATERS

Catalog Number	Product Description	Voltage/Frequency	Watts	Circulation Power	Temperature Range	Dimensions HxWxD
FH115230V300W	Heater, Fan, 300W, 6CFM, 115/230V	110-240VAC, 50/60 Hz, Fan 24VOC	300	6 CFM	14 - 158 deg. F	3.60x2.10x3.10 (91x53x79)
FH115230V350W	Heater, Fan, 350W, 10CFM, 115/230V	110-240VAC, 50/60 Hz, Fan 24VOC	350	10 CFM	14 - 158 deg. F	3.60x2.10x3.10 (91x53x79)

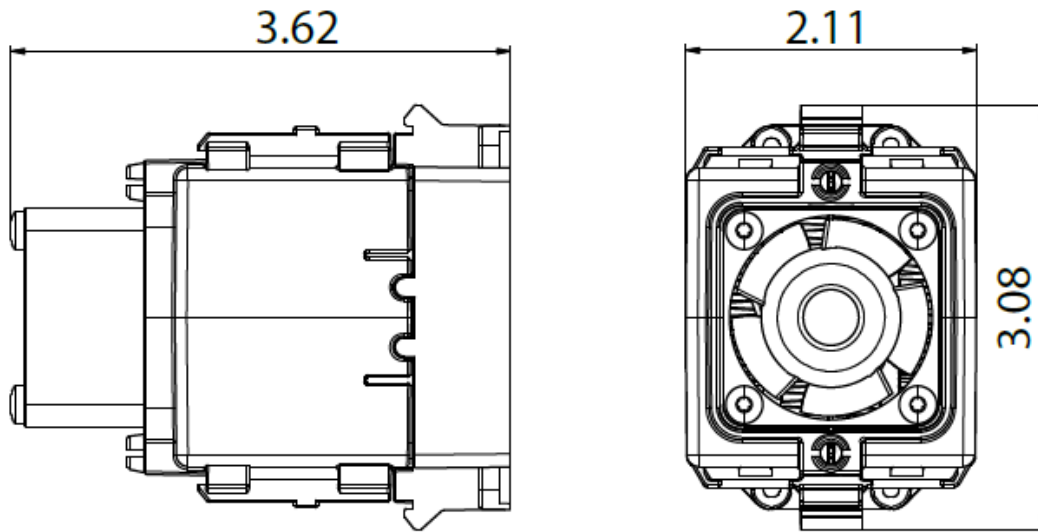

FH115230V (300W and 350W)



TANC1080C



TANO1080C



TTANCNC1080C



TTANCNO1080C



TTANONO1080C



TCTF060C

Industry Standards

- UL Recognized Component
- cUL Recognized Component
- CE Recognized
- CSA Rated

FEATURES-SPECIFICATIONS

Applications

- Designed to provide air temperature control and monitoring in enclosures that are set up to operate with heaters, fans, filter ventilators, heat exchangers and signal transmitters
- TTA (Twin Thermostat Adjustable) houses two separate thermostats, allowing the independent control

of heating and cooling equipment. Both thermostats have color coded dial disks for easy function recognition

Features

- Normally Closed Thermostat - for the control of heaters
- Normally Open Thermostat - for the control of cooling units, fans, filter ventilators or signal transmitters

- Color coded dial disk for easy identification (Red = NC / Blue = NO)
- Available in Fahrenheit or Celsius scale
- Easily installed by clip mounting on 35mm DIN rail
- Connection is 2 pole terminal for 14-20 AWG

TAN & TTA & TCT SERIES THERMOSTATS

Catalog Number	Temperature Scale	Temperature Range	Switching	Max Switching Capacity	For Product Type	Dimensions HxWxD
TANC14176F	Fahrenheit	14-176 deg F	Normally closed	16A-250V AC, 10A-50/60Hz, 72V DC - max. 30W	Heating	2.36x1.54x1.67 (60x39x42)
TANC1080C	Celsius	-10-80 deg C	Normally closed	16A-250V AC, 10A-50/60Hz, 72V DC - max. 30W	Heating	2.36x1.54x1.67 (60x39x42)
TANO14176F	Fahrenheit	14-176 deg F	Normally open	16A-250V AC, 10A-50/60Hz, 72V DC - max. 30W	Cooling	2.36x1.54x1.67 (60x39x42)
TANO1080C	Celsius	-10-80 deg C	Normally open	16A-250V AC, 10A-50/60Hz, 72V DC - max. 30W	Cooling	2.36x1.54x1.67 (60x39x42)
TTANCNO14176F	Fahrenheit	14-176 deg F	Normally closed/ Normally open	16A-250V AC, 10A-50/60Hz, 72V DC - max. 30W	Heating/Cooling	2.36x2.85x1.67 (60x72x42)
TTANCNO1080C	Celsius	-10-80 deg C	Normally closed/ Normally open	16A-250V AC, 10A-50/60Hz, 72V DC - max. 30W	Heating/Cooling	2.36x2.85x1.67 (60x72x42)
TTANCNC1080C	Celsius	-10-80 deg C	Normally closed/ Normally closed	16A-250V AC, 10A-50/60Hz, 72V DC - max. 30W	Heating	2.36x2.85x1.67 (60x72x42)
TTANCNC14176F	Fahrenheit	14-176 deg F	Normally closed/ Normally closed	16A-250V AC, 10A-50/60Hz, 72V DC - max. 30W	Heating	2.36x2.85x1.67 (60x72x42)
TTANONO1080C	Celsius	-10-80 deg C	Normally open/ Normally open	16A-250V AC, 10A-50/60Hz, 72V DC - max. 30W	Cooling	2.36x2.85x1.67 (60x72x42)
TTANONO14176F	Fahrenheit	14-176 deg F	Normally open/ Normally open	16A-250V AC, 10A-50/60Hz, 72V DC - max. 30W	Cooling	2.36x2.85x1.67 (60x72x42)
TCTF060C	Celsius	0-60 deg C	Changeover w/ thermal feedback	16A-250V AC, 10A-50/60Hz, 72V DC - max. 30W	Heating/Cooling	2.36x1.54x2.10 (60x39x53)
TCTF32140F	Fahrenheit	32-140 deg F	Changeover w/ thermal feedback	16A-250V AC, 10A-50/60Hz, 72V DC - max. 30W	Heating/Cooling	2.36x1.54x2.10 (60x39x53)



ETF-3000



HMC230V

Industry Standards

- UL Recognized Component
- cUL Recognized Component
- CE recognized

FEATURES-SPECIFICATIONS

Applications

- Designed to provide both air temperature and humidity control as well as monitoring in electrical and electronic enclosures
- Highly effective in ATM's, parking control gates, ticket dispensers and traffic control systems where equipment is exposed to a wide range of outdoor elements
- Resistive and inductive loads (heaters or fans) can be switched
- Easily installed by clip mounting on 35mm DIN rail

Features

- Independently senses the relative humidity and temperature

THERMOSTATS/HUMIDISTATS/HYGROSTATS

Catalog Number	Type	Operating Voltage	Temperature Scale	Switching Difference (Hysteresis)	Temperature Range	Relative Humidity Range	Dimensions HxWxD
ETF3000120F	Thermostat/Humidistat	120	Fahrenheit	Approx. 3.6 deg F (2 deg K)	32-140 deg F	50 to 90%	2.64x1.97x1.54 (67x50x39)
ETF3000	Thermostat/Humidistat	230	Celsius	Approx. 3.6 deg F (2 deg K)	0-60 deg C	50 to 90%	2.64x1.97x1.54 (67x50x39)
HMC230V	Hygrostat (mechanical changeover)	max. 230	Fahrenheit	4 +/- 1%	32-140 deg F	40 to 90%	2.36x1.54x1.67 (60x39x42)

HMC 230V

ETF 3000

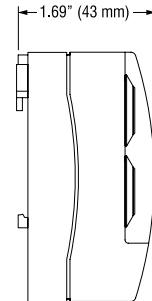
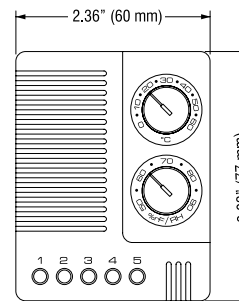
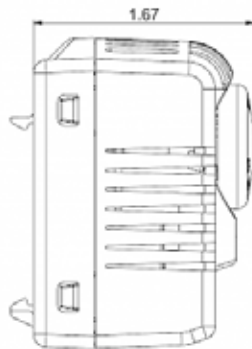
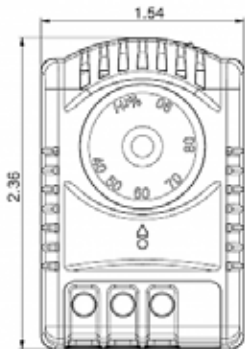

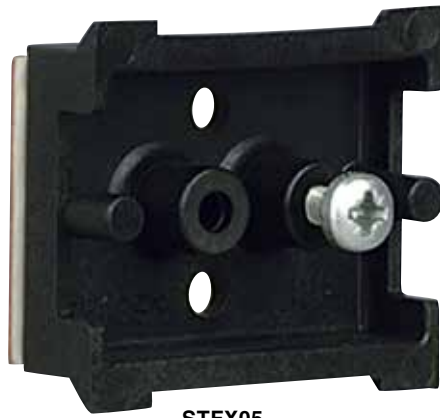

STFX05

Applications

Effective substitute for DIN rail or “Unistrut”. Multipurpose mounting device which allows the mounting of small DIN rail mountable appliances.

Features

- Provides direct snap-in mounting for thermostats, time relays, small heaters, terminals and other appliances with DIN rail mounting or by the use of screw holes
- Includes self adhesive backing which holds a continuous load of 1.1 lbs after a 24 hour curing period
- Holes for screw mounting are provided for heavier applications

STFX SERIES UNIVERSAL THERMOSTAT MOUNT

Catalog Number	Holding Capacity	Package Quantity	Temp. Range of Mounting Material	Dimensions HxWxD
STFX05	.44 lbs. (200g) initially 1.1 lbs. (500g) after 24 hour curing period	5	22-131°F (-30-55°C)	1.50x1.70x.55 (38x43x14)

**Sold in package quantity only*

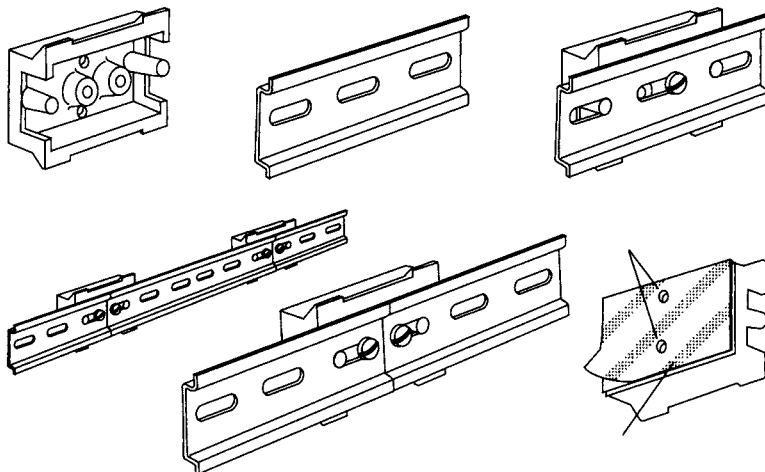
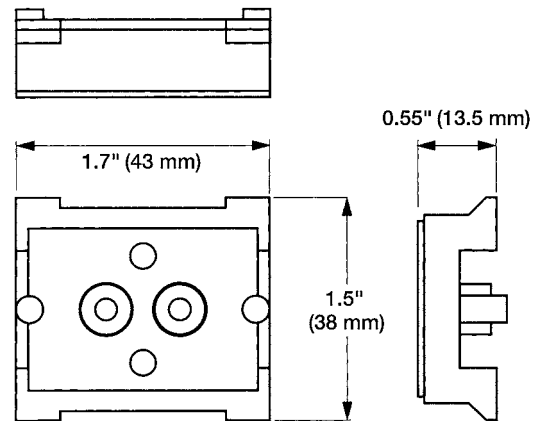



WAFMP4

FEATURES-SPECIFICATIONS

Features

- Designed to mount a fan and louver kit together
- Filter can be removed, cleaned, and replaced without any disassembly
- Fan mounting plate kit consists of the fan mounting plate, filter and all necessary mounting hardware

WAFMP SERIES FAN MOUNTING PLATE KIT

Filter & Fan Mounting Plate Kit	Fan*	Louver Kit Painted**	Fan Guard***
WAFMP4	WA4AXFN	WAVK0606	WAGARD4
WAFMP4	WA4AXFN2	WAVK0606	WAGARD4
WAFMP6	WA6AXFN	WAVK0806	WAGARD6
WAFMP6	WA6AXFN2	WAVK0806	WAGARD6
WAFMP10	WA10AXFN	WAVK0812	WAGARD10
WAFMP10	WA10AXFN2	WAVK0812	WAGARD10

Note: Fan, louver kit and fan guard are not included in the WAFMP kit and must be ordered separately

*See page M23 for information on fans.

**See page M24 for information on louver kits.

***See page M23 for information on fan guards.

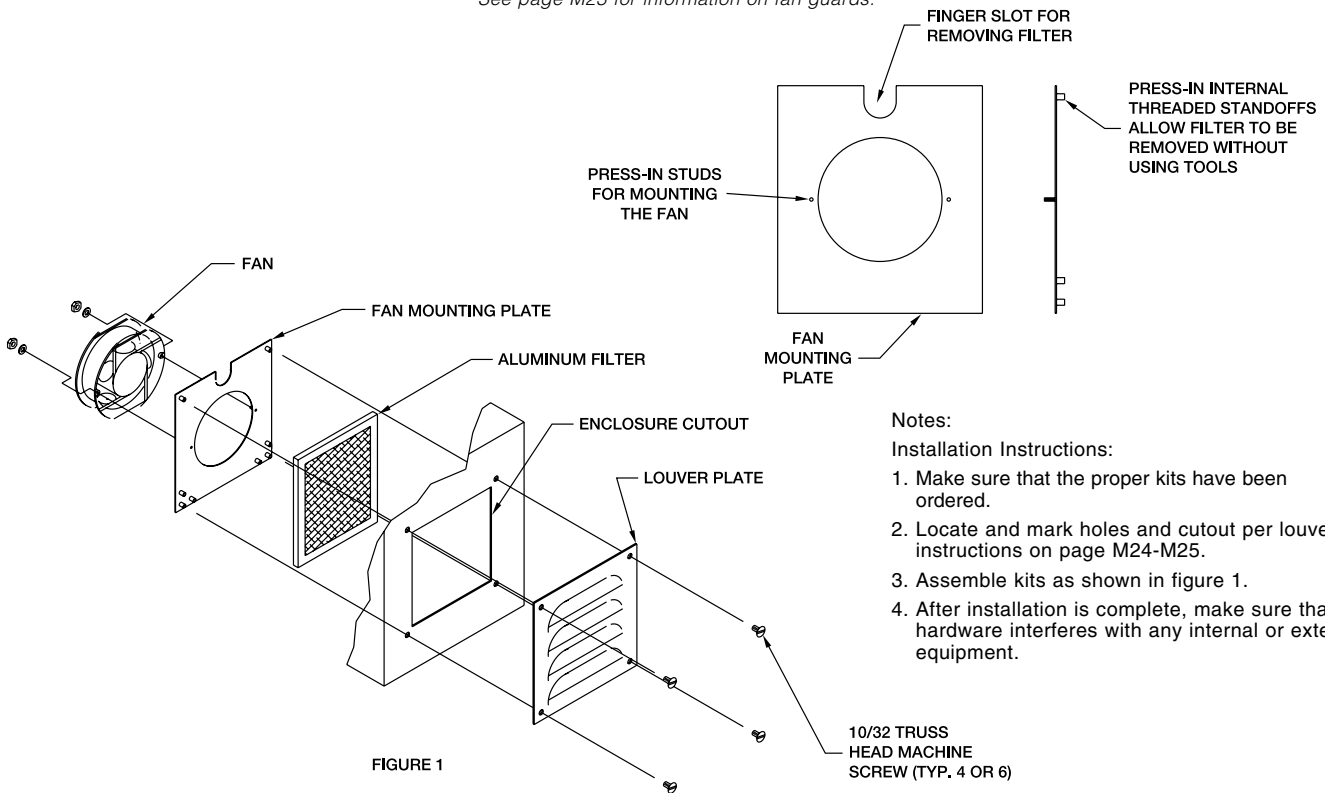

FIGURE 1

Notes:

Installation Instructions:

1. Make sure that the proper kits have been ordered.
2. Locate and mark holes and cutout per louver kit instructions on page M24-M25.
3. Assemble kits as shown in figure 1.
4. After installation is complete, make sure that no hardware interferes with any internal or external equipment.



FF8865CFM115VB

- CE Industry Standards**
 IP54
 IP55 (with fine filter mat)
 UR Recognized component

FEATURES-SPECIFICATIONS

Application

- The latest passive technology for fan cooling and pressurizing of enclosures
- Filtered passive ventilation can be provided by an exhaust filter for either convection cooling or in combination with a fan in forced air cooling
- Used in combination with thermostats, energy costs are reduced as the fan is only operating when needed

Features

- Available in 115 or 230 volt
- Polyurethane foam gasketed seal on mounting frame
- Shielded and self lubricating ball bearing fans
- Air channeling makes the filter fan particularly quiet in operation

- Durable, reusable filter mat included that can be cleaned up to 10 times by washing, blowing dry and lightly beating
- Replacement of the filter is done from the outside of the enclosure, without tools
- No tools or hardware required for installing cut-out on enclosure with mounting wall thickness of 0.039" - 0.098". Holes also provided in fan frame for screw mounting with wall mounting thickness under 0.039" or over 0.098"
- Available in light gray or black

Exhaust Grille & Filter Features

- Polyurethane foam gasketed seal on mounting frame
- Durable, reusable G3 filter mat included that can be cleaned up to 10 times by washing, blowing dry and lightly beating

- Replacement of the filter is done from the outside of the enclosure, without tools
- No tools or hardware required for installing cut-out on enclosure with mounting wall thickness of 0.039" - 0.098". Holes also provided in grille frame for screw mounting with wall mounting thickness under 0.039" or over 0.098"
- Available in light gray or black

Replacement Filter Mat Features

- Available in both G3 and G4 filter mat options
- Can be cleaned up to 10 times by washing, blowing dry and lightly beating

ENVIRONMENTAL CONTROLS FF SERIES - FILTER FANS/EXHAUST FILTER & MATS



EG44B



EG88G

FF SERIES FILTER FANS

Catalog Number		Operating Voltage	CFM	Current Consumption	Power Consumption	Noise Level	Mounting Depth	Enclosure Cut-out +/- 0.03(0.76)	Weight
Black Grille	Gray Grille								
FF4415CFM115VB	FF4415CFM115VG	115	15	127 mA	10W	42 dB	2.87 (73)	3.63x3.63 (92 x 92)	1.2 lbs (0.54 kg)
FF4415CFM230VB	FF4415CFM230VG	230	15	68 mA	11W	42 dB	2.87 (73)	3.63x3.63 (92 x 92)	1.2 lbs (0.54 kg)
FF6650CFM115VB	FF6650CFM115VG	115	50	220 mA	17W	44 dB	2.56 (65)	4.95x4.95 (126x126)	1.8 lbs (0.82 kg)
FF6650CFM230VB	FF6650CFM230VG	230	50	100 mA	16W	44 dB	2.56 (65)	4.95x4.95 (126x126)	1.8 lbs (0.82 kg)
FF8865CFM115VB	FF8865CFM115VG	115	65	202 mA	18W	49 dB	3.46 (88)	7.00x7.00 (178x178)	2.7 lbs (1.22 kg)
FF8865CFM230VB	FF8865CFM230VG	230	65	100 mA	18W	54 dB	3.46 (88)	7.00x7.00 (178x178)	2.7 lbs (1.22 kg)
FF1010159CFM115VB	FF1010159CFM115VG	115	159	270 mA	31W	55 dB	4.53 (115)	8.81x8.81 (224x224)	3.3 lbs (1.50 kg)
FF1010159CFM230VB	FF1010159CFM230VG	230	159	160 mA	36W	55 dB	4.53 (115)	8.81x8.81 (224x224)	3.3 lbs (1.50 kg)

EG SERIES EXHAUST GRILLE & FILTER

Catalog Number		For use with	Filter Material	Mounting Depth	Enclosure Cut-out +/- 0.03(0.76)	Weight
Black Grille	Gray Grille					
EG44B	EG44G	FF4415CFM115V	G3	0.65 (17)	3.63x3.63 (92 x 92)	0.15 lbs (0.07 kg)
EG44B	EG44G	FF4415CFM230V	G3	0.65 (17)	3.63x3.63 (92 x 92)	0.15 lbs (0.07 kg)
EG66B	EG66G	FF6650CFM115V	G3	0.84 (21)	4.95x4.95 (126x126)	0.40 lbs (0.18 kg)
EG66B	EG66G	FF6650CFM230V	G3	0.84 (21)	4.95x4.95 (126x126)	0.40 lbs (0.18 kg)
EG88B	EG88G	FF8865CFM115V	G3	0.84 (21)	7.00x7.00 (178x178)	0.57 lbs (0.26 kg)
EG88B	EG88G	FF8865CFM230V	G3	0.84 (21)	7.00x7.00 (178x178)	0.57 lbs (0.26 kg)
EG1010B	EG1010G	FF1010159CFM115V	G3	0.98 (25)	8.81x8.81 (224x224)	0.93 lbs (0.42 kg)
EG1010B	EG1010G	FF1010159CFM230V	G3	0.98 (25)	8.81x8.81 (224x224)	0.93 lbs (0.42 kg)

REPLACEMENT FILTER MATS

Catalog Number	
G3 Filter	G4 Filter
FR44G3	—
FR44G3	—
FR66G3	FR66G4
FR66G3	FR66G4
FR88G3	FR88G4
FR88G3	FR88G4
FR1010G3	FR1010G4
FR1010G3	FR1010G4



Industry Standards

UR, cUR, and CE recognized

IP43

(IP54 with optional WPFG Series gasket)

FEATURES-SPECIFICATIONS

Application

- The latest passive technology for fan cooling and pressurizing of enclosures
- Filtered passive ventilation can be provided by an exhaust filter for either convection cooling or in combination with a fan in forced air cooling
- Used in combination with thermostats, energy costs are reduced as the fan is only operating when needed

Features

- Available in 115 or 230 volt
- Polyurethane foam gasketed seal on mounting frame
- Shielded and self lubricating ball bearing fans

Application

- Air channeling makes the filter fan particularly quiet in operation
- Durable, reusable filter mat included that can be cleaned up to 10 times by washing, blowing dry and lightly beating
- Replacement of the filter is done from outside of enclosure, without tools
- No tools or hardware required for installing in cut out on enclosure with mounting wall thickness of 0.039" - 0.098", holes also provided in fan frame for screw mounting with wall mounting thickness under 0.039" or over 0.098"
- Available in light gray or black

Exhaust Grille & Filter Features

- Polyurethane foam gasketed seal on mounting frame
- Durable, reusable G3 filter mat included that can be cleaned up to 10 times by washing, blowing dry and lightly beating
- Replacement of the filter is done from outside of enclosure, without tools
- No tools or hardware required for installing in cut out on enclosure with mounting wall thickness of 0.039" - 0.098", holes also provided in grille frame for screw mounting with wall mounting thickness under 0.039" or over 0.098"
- Available in light gray or black



FF1313340CFM115VG



FF6629CFM230VB



FF SERIES FILTER FANS WITH GRILLE

Catalog Number		Voltage	CFM	Temperature Range (Fahrenheit)	Filtering Level DIN 24185	Sound Level	Required Cut out DIM +/- 0.03 (0.76)
Black Grille	Gray Grille						
FF449CFM12VB	FF449CFM12VG	12 VDC	9	14/131	85%	30	3.63x3.63 (92 x 92)
FF449CFM24VB	FF449CFM24VG	24 VDC	9	14/131	85%	30	3.63x3.63 (92 x 92)
FF449CFM115VB	FF449CFM115VG	115 VAC	9	14/131	85%	33	3.63x3.63 (92 x 92)
FF449CFM230VB	FF449CFM230VG	230 VAC	9	14/131	85%	33	3.63x3.63 (92 x 92)
FF4415CFM115VB	FF4415CFM115VG	115 VAC	15	14/131	85%	42	3.63x3.63 (92 x 92)
FF4415CFM230VB	FF4415CFM230VG	230 VAC	15	14/131	85%	42	3.63x3.63 (92 x 92)
FF4429CFM24VB	FF4429CFM24VG	24 VDC	29	14/131	85%	59	3.63x3.63 (92 x 92)
FF6628CFM24VB	FF6628CFM24VG	24 VDC	28	14/131	85%	48	4.95x4.95 (126x126)
FF6628CFM48VB	FF6628CFM48VG	48 VDC	28	14/131	85%	48	4.95x4.95 (126x126)
FF6629CFM115VB	FF6629CFM115VG	115 VAC	29	14/131	85%	49	4.95x4.95 (126x126)
FF6629CFM230VB	FF6629CFM230VG	230 VAC	29	14/131	85%	54	4.95x4.95 (126x126)
FF6650CFM115VB	FF6650CFM115VG	115 VAC	50	14/131	85%	44	4.95x4.95 (126x126)
FF6650CFM230VB	FF6650CFM230VG	230 VAC	50	14/131	85%	44	4.95x4.95 (126x126)
FF8859CFM24VB	FF8859CFM24VG	24 VDC	59	14/131	85%	42	7.00x7.00 (178x178)
FF8865CFM115VB	FF8865CFM115VG	115 VAC	65	14/131	85%	49	7.00x7.00 (178x178)
FF8865CFM230VB	FF8865CFM230VG	230 VAC	65	14/131	85%	54	7.00x7.00 (178x178)
FF8877CFM115VB	FF8877CFM115VG	115 VAC	77	14/131	85%	44	7.00x7.00 (178x178)
FF8877CFM230VB	FF8877CFM230VG	230 VAC	77	14/131	85%	44	7.00x7.00 (178x178)
FF101071CFM115VB	FF101071CFM115VG	115 VAC	71	14/131	85%	49	8.81x8.81 (224x224)
FF101071CFM230VB	FF101071CFM230VG	230 VAC	71	14/131	85%	54	8.81x8.81 (224x224)
FF101082CFM24VB	FF101082CFM24VG	24 VDC	82	14/131	85%	42	8.81x8.81 (224x224)
FF101082CFM48VB	FF101082CFM48VG	48 VDC	82	14/131	85%	43	8.81x8.81 (224x224)
FF1010132CFM24VB	FF1010132CFM24VG	24 VDC	132	14/131	85%	58	8.81x8.81 (224x224)
FF1010132CFM48VB	FF1010132CFM48VG	48 VDC	132	14/131	85%	60	8.81x8.81 (224x224)
FF1010159CFM115VB	FF1010159CFM115VG	115 VAC	159	14/131	85%	50	8.81x8.81 (224x224)
FF1010159CFM230VB	FF1010159CFM230VG	230 VAC	159	14/131	85%	55	8.81x8.81 (224x224)
FF1010159CFM115VB	FF1010159CFM115VG	115 VAC	159	14/131	85%	50	8.81x8.81 (224x224)
FF1313317CFM400VB	FF1313317CFM400VG	400 VAC3	317	14/158	85%	73	11.49x11.49 (292x292)
FF1313340CFM115VB	FF1313340CFM115VG	115 VAC	340	14/131	85%	69	11.49x11.49 (292x292)
FF1313340CFM115VB	FF1313340CFM115VG	115 VAC	340	14/131	85%	69	11.49x11.49 (292x292)
FF1313340CFM230VB	FF1313340CFM230VG	230 VAC	340	14/131	85%	68	11.49x11.49 (292x292)
FF1313547CFM400VB	FF1313547CFM400VG	400 VAC3	547	-13/113	85%	71	11.49x11.49 (292x292)
FF1313547CFM115VB	FF1313547CFM115VG	115 VAC	547	-13/113	85%	72	11.49x11.49 (292x292)
FF1313547CFM230VB	FF1313547CFM230VG	230 VAC	547	-13/113	85%	70	11.49x11.49 (292x292)
TOP MOUNT FILTER FANS - LIGHT GRAY ONLY							
	FFTM288CFM115VG	115 VAC	288	14/131	85%	72	6.89x6.89 (175x175)
	FFTM288CFM230VG	230 VAC	288	14/131	85%	72	6.89x6.89 (175x175)

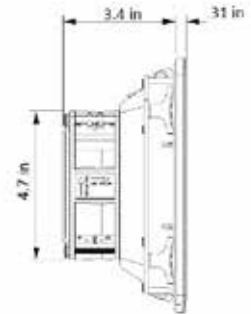
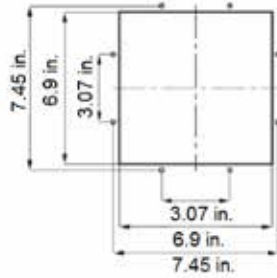
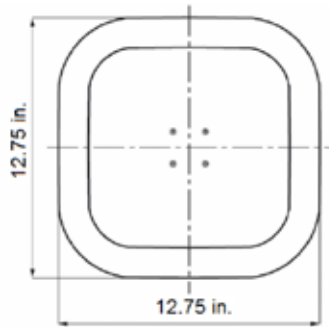

FF8865CFM (115V & 230V)

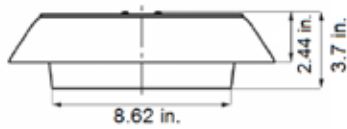

FFTM288CFM

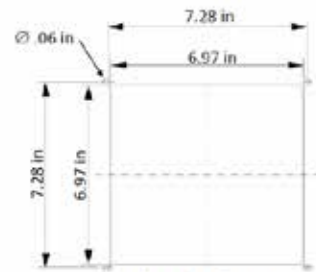

Mounting Cutout

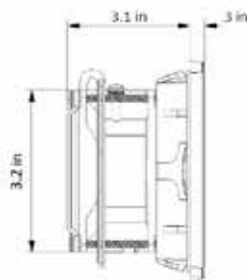

FF4415CFM (115V & 230V)

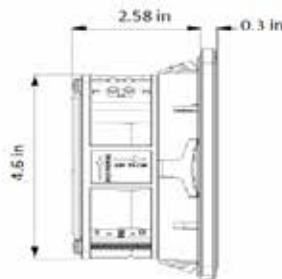

FF6650CFM (115V & 230V)

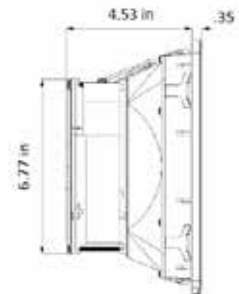

FF1010159CFM (115V & 230V)

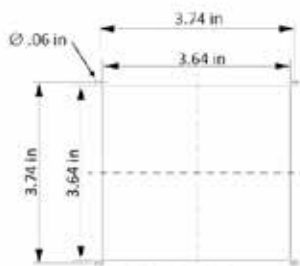

Mounting Cutout

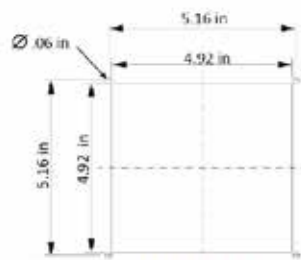

Mounting Cutout

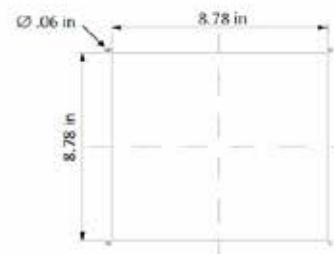

Mounting Cutout



EG44B



EG88G

Industry Standards

IP43

(IP54 with optional WPF Series gasket)

FEATURES-SPECIFICATIONS

FF SERIES EXHAUST GRILLE WITH FILTER

Catalog Number		Filtering Level	Required Cut out DIM +/- 0.03 (0.76)
Black Grille	Gray Grille		
EG44B	EG44G	85%	3.63x3.63 (92 x 92)
EG66B	EG66G	85%	4.95x4.95 (126x126)
EG88B	EG88G	85%	7.00x7.00 (178x178)
EG1010B	EG1010G	85%	8.81x8.81 (224x224)
EG1313B	EG1313G	85%	11.49x11.49 (292x292)

FF SERIES EXHAUST FILTER MATS

Catalog Number		Use With Filter Fan	Use With Exhaust Filter	Filtering Level
G3 Filter	G4 Filter			
FR44G3	—	FF44's	EG44B & EG44G	85%
FR66G3	FR66G4	FF66's	EG66B & EG66G	85%
FR88G3	FR88G4	FF88's	EG88B & EG88G	85%
FR1010G3	FR1010G4	FF1010's	EG1010B & EG1010G	85%
FR1313G3	FR1313G4	FF1313's	EG1313B & EG1313G	85%

Screw Mounting Kit For When Enclosure Wall
Mounting Thickness Is Under 0.039" (19 Ga.) Or Over 0.098" (13 Ga.)
Catalog Number = FFSMK
(1 Kit Needed For Each Unit When Required)

Mounting Frame Features: Snap In design requires no tools or hardware
for installing from the exterior of the enclosure into the cut out on enclosure
with mounting wall thickness of 0.039" - 0.098", holes also provided
in frame for screw mounting with wall mounting thickness under 0.039"
or over 0.098"

