

# SECTION F

## Table of Contents



### Circuit-Lock® Unfused Disconnect Switches



### Fused Disconnects, MotorQuick® and VFDs



### Hazardous Locations



Product	Page	Product	Page
Products at a Glance	F-2	Ratings Quick Reference Guide	F-17
New Innovations		Hazardous Locations	
<b>inSIGHT™</b> Phase Indicating Disconnect Switches	F-3	Unfused Disconnect Switches	F-19
Circuit-Lock® Switched Disconnect Enclosures		600V AC Manual Toggle Controllers/Disconnects	F-21
Non-Metallic Labelless Units	F-5	NEMA 1 Disconnect Switches	F-22
Stainless Steel, Square Top and Sloped Top Units	F-7	NEMA 3 and 3R Disconnect Switches	F-23
Accessories and Replacement Parts	F-8	Manual Motor Controllers	
Dimensions and Specifications	F-9	30 Amp, 600 Volts AC	F-24
MotorQuick® Disconnect Switches		40, 50, 60 and 85 Amp, 600 Volts AC	F-25
Cost of Ownership Analysis	F-10	NEMA 4X Disconnect Switches	F-26
Labelless Disconnect Switches and Accessories	F-11	Pendant Pushbutton Stations	
Dimensions and Specifications	F-12	CPB2 and PBS Series	F-27
200 Amp Disconnect Switches	F-13	Accessories and Replacement Parts	F-28
Circuit-Lock® Fused Disconnect Switches			
30 and 60 Amp Units	F-15		
Horsepower Ratings and Specifications	F-16		

# Switched Disconnects and Enclosures

## Products at a Glance

### UL508/UL60947 Circuit-Lock® Motor Disconnects



#### Labelless Circuit-Lock® Disconnect Switches

- Non-metallic and stainless steel options
- Available in 30, 60 and 100 Amp versions
- IP69k and Type 4X, 12K water ingress protection
- Permanent labelless markings
- Available with six highly visible LED Indicators
- Certified by NSF for hygiene in Food Processing applications
- Highly visible red handle which meets OSHA LO/TO capabilities
- Accepts up to 2 auxiliary contacts
- Cover cannot be removed with switch in the "ON" position



#### Enhanced Features:

- **inSIGHT** - LED indicators provide visual confirmation of power by phase
- **MotorQuick**® - Plug and play functionality to reduce Total Cost of Ownership
- **VFDs** - Factory installed auxiliary contact for safe disconnecting in VFD applications
- **JOG** - Factory installed Jog switch for point of use communication to PLC/VFD
- **Stainless Steel Sloped Top** - 15° rounded top aids run-off by minimizing horizontal surfaces



### UL98 Circuit-Lock® Motor Disconnects



#### 200A Circuit-Lock® Disconnect Switches

- Non-metallic & stainless steel
- Type 4X, 12
- Accepts up to 2 auxiliary contacts
- OSHA Compliant Lockout/Tagout handle
- Unable to open the cover when "ON"; cover locked when energized



#### Circuit-Lock® 30 and 60 Amp Fused Disconnect Switches

- Non-metallic enclosure meets UL 50E Type 4X (watertight) 12 (dust-tight) and IP66 suitability requirements
- Removable door for ease of wiring and installation
- Switch accepts Class "J" fuses and up to 2 auxiliary contacts

### UL98 and UL508 Disconnect Switches



#### Hazardous Locations

- Compact NEMA 4X enclosure and footprint allows easy installation in tight locations
- Top and bottom drilled and tapped conduit entrances
- For use as motor disconnects

### UL508 Switches



#### Disconnect Switches

- Thermoset body provides high resistance to electrical arc tracking
- Withstands high temperatures
- Provides long-life reliability

## New Innovations

### Circuit-Lock® 30A Disconnects with LED Indicators

Hubbell's new 30A Circuit-Lock Disconnect with integral phase indication LEDs redefines the benchmark for safety by providing insight into the enclosure while in use. Six highly visible LEDs (3 line side/3 load side) communicate the electrical status of the switch by phase. This voltage detection feature significantly improves existing safety and maintenance procedures by visually providing personnel critical information prior to removing the enclosure cover; e.g. a welded contact or dropped phase.

Hubbell **inSIGHT™** phase indicating disconnect switches are available in non-metallic and stainless steel versions. Replacement covers are available for upgrades to existing installations. With an ever growing focus on safety improvements Hubbell **inSIGHT™** disconnects provide a difference you literally can see.

# inSIGHT™

*Insight (n): the power or act of seeing into a situation*



#### Housing Design

- Six highly visible integral phase identification LEDs
- LEDs provide secondary means of visual confirmation of make/break on all phases
- Cover cannot be removed with switch in the "ON" position



#### Safety

- Verification of opening of load side contacts
- Highly visible red handle can be locked in the OFF position as a method of compliance with OSHA Lockout/Tagout requirements



### 30 Amp Unfused Disconnect Switches with LEDs\*

Description	Non-Metallic	Stainless Steel Square Top	Stainless Steel Sloped Top
Disconnect switch with LEDs.	<b>HBLDS3P</b>	<b>HBLDS3SSP</b>	<b>HBLDS3SSRP</b>
Disconnect switch with HBLAC1 auxiliary contact.	<b>HBLDS3PAC</b>	—	—
Disconnect with Jog switch and LEDs.	<b>HBLDS3PJ</b>	—	<b>HBLDS3SSRPJ</b>

### LED Replacement Covers

Description	Non-Metallic	Stainless Steel Square Top	Stainless Steel Sloped Top
Replacement cover for 30A switches with LEDs.	<b>HBLDS3RCP</b>	<b>HBLDS3SSRCP</b>	<b>HBLDS3SSRRCP</b>

Note: For use with 3Ø Y configurations only.

### Auxiliary Contacts

Description	Catalog Number
"Break After Main Break", 1 set of n/o contacts, 1 set of n/c contacts.	<b>HBLAC1**</b>
"Break Before Main Break", 1 set of n/o contacts for use with variable frequency drives.	<b>HBLAC2**</b>

Note: \*Certified by NSF, International.

\*\*Up to two auxiliary contacts per enclosure.



**HBLDS3P**



**HBLDS3SSRP**

## Features and Benefits

### Non-Metallic Labelless Circuit-Lock® Switched Disconnect Enclosures

NEC section 430.102(B) requires each motor controller to have a disconnect within line of sight from the motor and driven equipment. Hubbell's Circuit-Lock® Unfused Disconnect Switches are UL listed as a manual motor controller and also "suitable as a motor disconnect" and meet these code requirements.

- Constructed from corrosion and impact resistant UV stabilized non-metallic material
- IP69k and Type 4X, 12K water ingress protection
- Certified by NSF for hygiene in food processing applications
- Highly visible red handle which meets OSHA Lockout/Tagout capabilities
- Cover cannot be removed with switch in the "ON" position
- Accepts up to 2 Auxiliary contacts
- Reversible interior accommodates top or bottom conduit opening



**HBLDS3**  
(Cover off)

**HBLDS3**  
(Cover)

#### Enhanced Features:

- Adjustable mounting feet are now 40% stronger to help prevent nuisance breakage
- Product ratings are permanently laser-marked to the HBLDS3 devices and will not wash off
- Truly captive screws prevent lost screws
- Now shipped from factory as bottom feed for quicker installation in 4X applications



#### LED Indicators

- Six highly visible integral phase identification LEDs
- External LEDs provide secondary means of visual confirmation of make/break on all phases



#### Variable Frequency Drive (VFD)

- Integrates a verified break before break auxiliary contact factory installed in our HBLDS series
- Prevents downtime from out of sequence equipment shutdowns



#### Jog Switch

- Cost savings by utilizing existing space in the motor disconnect enclosure reducing parts and labor costs
- Convenience by having point of use control circuit to PLC within line of sight of the motor
- Added safety by allowing maintenance personnel the functionality to "Try Out" after Lockout/Tagout



#### MotorQuick® Version

- Significantly reduces the time it takes to replace motors by combining the plug-and-play technology of the LINKOSITY® power system
- Motor rotation can be pre-checked in a maintenance shop to further speed the installation

## Non-Metallic Labelless Circuit-Lock® Switched Disconnect Enclosures\*

Description	30 Amp	60 Amp	100 Amp
Disconnect switch.	<b>HBLDS3</b>	<b>HBLDS6</b>	<b>HBLDS10</b>
Disconnect switch for use with variable frequency drives.	<b>HBLDS3VFD</b>	<b>HBLDS6VFD</b>	<b>HBLDS10VFD</b>
Disconnect switch with HBLAC1 auxiliary contact.	<b>HBLDS3AC</b>	<b>HBLDS6AC</b>	<b>HBLDS10AC</b>
Disconnect switch without conduit knockout or conduit fitting.	<b>HBLDS3NK</b>	—	—
Disconnect switch with HBLAC1 auxiliary contact without conduit knockout or conduit fitting.	<b>HBLDS3ACNK</b>	—	—
Disconnect switch with 3 auxiliary contacts, without conduit knockouts. Break before main break – 1 set “normally open”, 1 set “normally closed”. Break after main break – 2 sets “normally open”, 1 set “normally closed”.	<b>HBLDS33ACNK</b>	—	—



**HBLDS3**



**HBLDS3VFD**



**HBLDS3P**



**HBLDS3J**



**HBLAC1**

**HBLAC2**

## Non-Metallic Disconnects with LEDs

Description	30 Amp	60 Amp	100 Amp
Disconnect switch with LEDs.	<b>HBLDS3P</b>	—	—
Disconnect with Jog switch and LEDs.	<b>HBLDS3PJ</b>	—	—

Note: For use with 3Ø Y configurations only.

## Non-Metallic Labelless Disconnects with Jog Switch

Description	30 Amp	60 Amp	100 Amp
Disconnect switch.	<b>HBLDS3J</b>	<b>HBLDS6J</b>	—
Disconnect switch for use with variable frequency drives.	<b>HBLDS3VFDJ</b>	—	—
Disconnect switch with HBLAC1 auxiliary contact.	<b>HBLDS3ACJ</b>	—	—

## Auxiliary Contacts for 30, 60 and 100 Amp Switch, NEMA A600 Pilot Duty

Description	Catalog Number
“Break After Main Break”, 1 set of n/o contacts, 1 set of n/c contacts.	<b>HBLAC1**</b>
“Break Before Main Break”, 1 set of n/o contacts for use with variable frequency drives.	<b>HBLAC2**</b>

Note: \*Certified by NSF, International.

\*\*Up to two auxiliary contacts per enclosure. Not for use with HBLDS33ACNK.

30A Units are supplied with one ¼ in. NPT Raintight conduit fitting.

60A and 100A Units are supplied with two 1¼ in. NPT Raintight conduit fittings.

## Variable Frequency Drive Diagram

When installing a disconnect in series with a VFD it is critical to include the correct auxiliary contact. Through extensive testing, Hubbell has determined the timing of our early break auxiliary contact HBLAC2 safely disconnects the power by signaling the VFD that the motor disconnect is being turned OFF. The VFD then executes a coast-to-stop preventing any damage to the disconnect switch and the VFD output device.

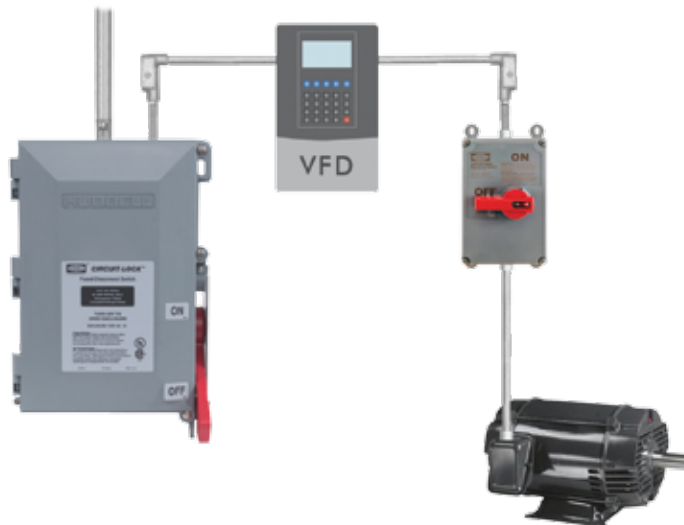

## Features and Benefits

### Stainless Steel Circuit-Lock® Unfused Switched Disconnect Enclosures\*

NEC section 430.102(B) requires each motor controller to have a disconnect within line of sight from the motor and driven equipment. Hubbell's Circuit-Lock® Unfused Disconnect Switches are UL listed as a manual motor controller and also "suitable as a motor disconnect" and meet these code requirements.

- Formed in nonporous 304 stainless steel
- IP69k and Type 4X, 12K water ingress protection
- Certified by NSF for hygiene in food processing applications
- Fixed offset 1/4 inch mounting feet meet NEC airspace requirements for metal enclosures
- Labelless markings on the cover
- Highly visible red handle which meets OSHA Lockout/Tagout capabilities
- Cover cannot be removed with switch in the "ON" position
- Accepts up to 2 Auxiliary contacts

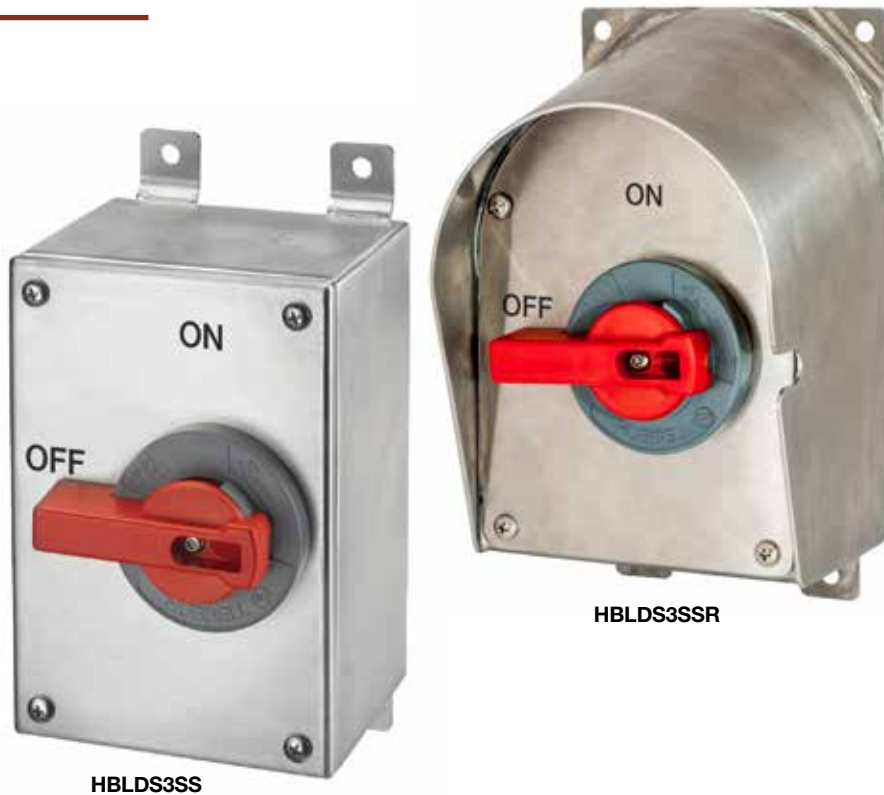

**More than ever food and beverage processing facilities see the value of investing in intelligent design and following best practices in hygiene.**

The sloped top enclosure is consistent with these best practices. Horizontal surfaces have been minimized to assist with getting it clean and keeping it clean.



#### LED Indicators

- Six highly visible integral phase identification LEDs
- External LEDs provide secondary means of visual confirmation of make/break on all phases



#### Housing Design

- Sloped top design sheds water and debris
- Fully shrouded handle prevents damage to the handle
- Captive screws prevent lost screws



#### Jog Switch

- Cost Savings by utilizing existing space in the motor disconnect enclosure reducing parts and labor costs
- Convenience by having point of use control circuit to PLC within line of sight of the motor
- Added Safety by allowing maintenance personnel the functionality to "Try Out" after Lockout/Tagout



#### Labor Savings

- 15° Sloped Top version available pre-drilled with 3/4 inch stainless steel hubs for bottom feed applications
- Ample gutter space for hassle free installation

## Stainless Steel Circuit-Lock® Unfused Switched Disconnect Enclosures\*

Description	30 Amp	60 Amp	100 Amp
Square Top disconnect switch.	<b>HBLDS3SS</b>	<b>HBLDS6SS</b>	<b>HBLDS10SS</b>
Square Top disconnect switch for use with variable frequency drives.	<b>HBLDS3SSVFD</b>	<b>HBLDS6SSVFD</b>	<b>HBLDS10SSVFD</b>
Square Top disconnect switch with HBLAC1 auxiliary contact.	<b>HBLDS3SSAC</b>	<b>HBLDS6SSAC</b>	<b>HBLDS10SSAC</b>
Sloped Top disconnect switch.	<b>HBLDS3SSR</b>	<b>HBLDS6SSR</b>	<b>HBLDS10SSR</b>
Sloped Top disconnect, 4X with (2) 3/4 inch stainless steel hubs.	<b>HBLDS3SSR2K</b>	—	—
Sloped Top disconnect switch for use with variable frequency drives.	<b>HBLDS3SSRVFD</b>	<b>HBLDS6SSRVFD</b>	<b>HBLDS10SSRVFD</b>
Sloped Top disconnect switch with HBLAC1 auxiliary contact.	<b>HBLDS3SSRAC</b>	<b>HBLDS6SSRAC</b>	<b>HBLDS10SSRAC</b>
Sloped Top enclosure, Blank.	<b>HBLDSSRNK3</b>	<b>HBLDSSRNK6</b>	—



**HBLDS3SS**



**HBLDS3SSJ**

## Stainless Steel Disconnects with LEDs

Description	Stainless Steel Square Top	Stainless Steel Sloped Top
Disconnect switch with LEDs.	<b>HBLDS3SSP</b>	<b>HBLDS3SSRP</b>
Disconnect with Jog switch and LEDs.	—	<b>HBLDS3SSRPJ</b>

Note: For use with 3Ø Y configurations only.

## Stainless Steel Disconnects with Jog Switch

Description	Stainless Steel Square Top	Stainless Steel Sloped Top
30A disconnect with Jog switch.	<b>HBLDS3SSJ</b>	<b>HBLDS3SSRJ</b>



**HBLDS3SSR**

## Stainless Steel Conduit Hubs

Description	Catalog Number
3/4 inch stainless steel conduit hub.	<b>HUB75SS</b>
1 1/4 inch stainless steel conduit hub.	<b>HUB125SS</b>

## Auxiliary Contacts for 30, 60 and 100 Amp Switch, NEMA A600 Pilot Duty

Description	Catalog Number
"Break After Main Break", 1 set of n/o contacts, 1 set of n/c contacts.	<b>HBLAC1**</b>
"Break Before Main Break", 1 set of n/o contacts for use with variable frequency drives.	<b>HBLAC2**</b>

Note: \*Certified by NSF, International.

\*\*Up to two auxiliary contacts per enclosure. Not for use with HBLDS33ACNK.

30A Units are supplied with one 3/4 in. NPT Raintight conduit fitting.

60A and 100A Units are supplied with two 1 1/4 in. NPT Raintight conduit fittings.



**HBLDS3SSRPJ**

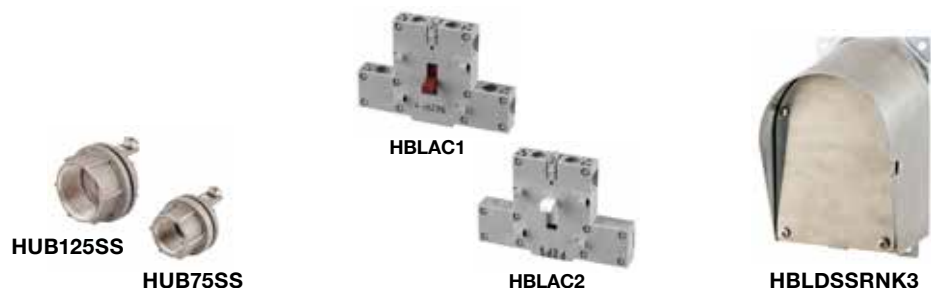

**HUB125SS**

**HUB75SS**

**HBLAC1**

**HBLAC2**

**HBLDSSRNK3**



HBLDS3RCP



HBLDS3RCJ



HBLDS3SSRC



HBLDS3SSRRC



HBLDS3SSRRCP

## Non-Metallic Replacement Covers

Description	30 Amp	60 Amp	100 Amp
For disconnect switch.	<b>HBLDS3RC</b>	<b>HBLDS6RC</b>	<b>HBLDS10RC</b>
For disconnect switch with LEDs.	<b>HBLDS3RCP</b>	—	—
For disconnect switch with LEDs and Jog.	<b>HBLDS3RCPJ</b>	—	—
For disconnect with Jog switch.	<b>HBLDS3RCJ</b>	<b>HBLDS6RCJ</b>	—

## Stainless Steel Replacement Covers

Description	30 Amp	60 Amp	100 Amp
For square top disconnect switch.	<b>HBLDS3SSRC</b>	<b>HBLDS60100SSRC</b>	<b>HBLDS60100SSRC</b>
For square top disconnects with LEDs.	<b>HBLDS3SSRCP</b>	—	—
For square top disconnect with Jog switch.	<b>HBLDS3SSRCJ</b>	—	—
For sloped top disconnect switch.	<b>HBLDS3SSRRC</b>	<b>HBLDS60100SSRRC</b>	<b>HBLDS60100SSRRC</b>
For sloped top disconnect with LEDs.	<b>HBLDS3SSRRCP</b>	—	—
For sloped top disconnect with Jog switch.	<b>HBLDS3SSRRCJ</b>	—	—

## Replacement Ground Block

Description	Catalog Number
For 30A switches.	<b>HBL30RGB</b>
For 60A and 100A switches.	<b>HBL60100RGB</b>

## Replacement Neutral Block

Description	Catalog Number
For 30A switches.	<b>HBL30RNB</b>
For 60A switches.	<b>HBL60RNB</b>
For 100A switches.	<b>HBL100RNB</b>

## Replacement Switches

Description	Catalog Number
For 30A switches.	<b>HBLDS3RS</b>
For 60A and 100A switches.	<b>HBLDS60100RS</b>
For HBLDS33ACNK.	<b>HBLDS33ACRS</b>

## Replacement Mounting Feet

Description	Catalog Number
For 30A non-metallic switches.	<b>HBLRFT1<sup>Δ</sup></b>
For 60A and 100A non-metallic switches.	<b>HBLRFT2<sup>Δ</sup></b>

Note: <sup>Δ</sup> Package of 10 feet and 10 screws.



HBL30RGB



HBL30RNB



HBLDS3RS



HBLRFT1



# Switched Disconnects and Enclosures

## Dimensions

Key	Labelless Non-Metallic		Stainless Steel, Square Top		Stainless Steel, Sloped Top	
	30A inch (mm)	60A/100A inch (mm)	30A inch (mm)	60A/100A inch (mm)	30A inch (mm)	60A/100A inch (mm)
<b>A</b>	6.00 (152)	7.75 (197)	—	—	—	—
<b>B</b>	5.12 (130)	6.87 (175)	4.87 (124)	7.30 (185)	5.41 (137)	7.66 (195)
<b>C</b>	4.12 (105)	4.75 (121)	3.30 (84)	5.50 (140)	4.50 (114)	6.45 (164)
<b>D</b>	6.62 (168)	8.00 (203)	—	—	—	—
<b>E</b>	7.62 (194)	9.95 (253)	7.05 (179)	10.30 (262)	8.60 (218)	11.41 (290)
<b>F</b>	8.50 (216)	11.00 (279)	8.38 (213)	11.63 (296)	8.22 (209)	11.17 (284)
<b>G</b>	4.12 (105)	5.94 (151)	5.39 (137)	5.93 (151)	4.92 (125)	6.10 (155)

## Horsepower Ratings

Voltage	30A	30A*	60A	100A
1Ø 120V AC	1	1	7.5	7.5
1Ø 200–240V AC	3	2.5	15	15
1Ø 480V AC	5	5	30	30
3Ø 200–240V AC	7.5	5	30	30
3Ø 480V AC	15	10	50	50
3Ø 600V AC	15	10	50	50

Note: \*HBLDS33ACNK.

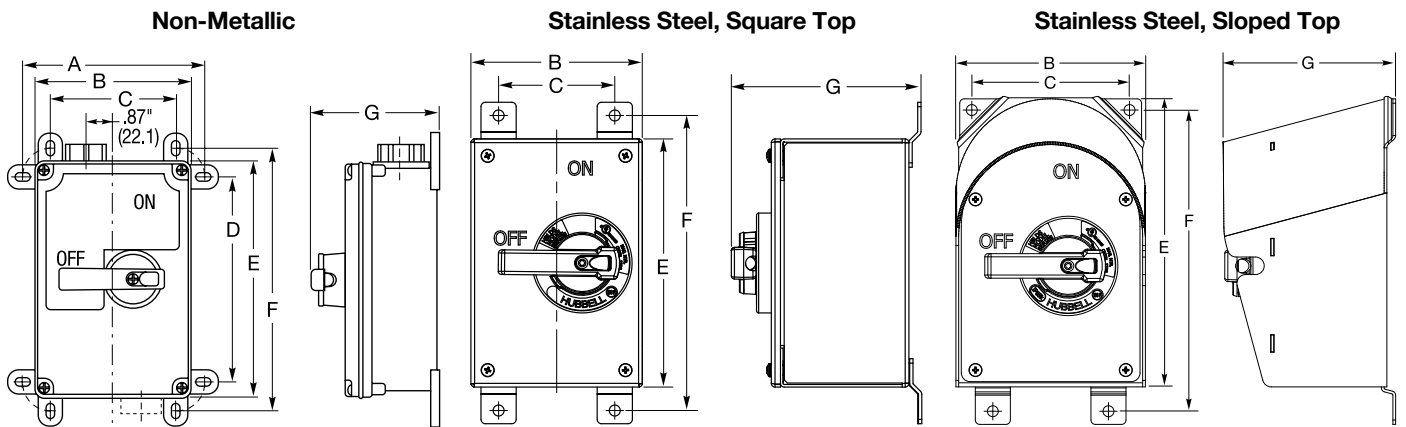

## Circuit-Lock® Unfused Disconnect Switches

### Specifications

#### Moisture Resistance

Indoor and Outdoor – Type 4X (Wash down, Corrosion resistant);  
Indoor – 30, 60A and 100A Type 12 (Dust-tight, Falling Dirt, Noncorrosive Liquids).  
UL94-5VA and V0 Classification.

#### Flammability

#### Operating Temperature

Maximum Continuous 75°C; Minimum Continuous -40°C without impact.

#### UV Resistance

All materials are UV stabilized.

#### Dielectric Voltage

Withstands 3000V AC minimum.

#### Max. Working Voltage

600V AC RMS.

#### Current Interrupting

Certified for current interrupting at full rated current and voltage.

#### Short Circuit Current Ratings (SCCR): (Motor Disconnect)

- 30/60/100A: Suitable for use on a circuit capable of delivering not more than 10kA RMS symmetrical, 600V AC max.
- 30A: Suitable for use on a circuit capable of delivering not more than 65kA RMS symmetrical, 600V AC max. when protected by Class J fuses rated 30A max.
- 60/100A: Suitable for use on a circuit capable of delivering not more than 65kA RMS symmetrical, 600V AC max. when protected by Class J fuses rated 100A max.

In accordance with UL, CSA and international conventions.

#### Terminal Identification

Identification and ratings are part of external label.

#### Product Identification

#### Mounting

Non-Metallic - External fully adjustable feet. Stainless Steel - Feet are fixed.

#### Impact Resistance

In accordance with UL 746C.

### Materials

Part	Non-Metallic	Stainless Steel
Base	PBT	#14 Gauge Type 304 Stainless Steel
Top	PBT	#14 Gauge Type 304 Stainless Steel
Handle	PBT	PBT
Conduit Hub	Zinc 30A Unfused - ¾ in. Zinc 60/100A Unfused - 1¼ in.	Zinc 30A - ¾ in. Zinc 60/100A - 1¼ in.
Enclosure Gasket	Neoprene	Neoprene
Shaft (Unfused)	PBT	PBT
Shaft Seal	Molded Neoprene	Molded Neoprene
Frame	Galvanized Steel	N/A
Enclosure Screws	Stainless Steel 300 Series	Stainless Steel

Dimensions in Inches (mm)

# Switched Disconnects and Enclosures

## Plug and Play Technology

MotorQuick® significantly reduces the time it takes to replace motors by combining the plug-and-play technology of the LINKOSITY® power system with the versatility of Circuit-Lock® motor disconnect switches. Quick disconnect terminations will reduce motor change-out time by approximately 65%. Keeping spare motors

already pre-wired with a LINKOSITY® inlet enables wiring to be done off-line when it is convenient, not critical. Motor rotation can be pre-checked in a maintenance shop to further speed the installation. The net result is that equipment is up and running in a fraction of the time, helping improve the bottom line.



## MotorQuick® Cost of Ownership Analysis

### Traditional Motor Changeout

Catalog Number	Total Material Cost	Labor Cost/ Hr	Downtime	Total Labor Cost	Downtime Cost/hr	Total Downtime Cost	Total Cost
<b>HBL1389D</b>	\$106.00	\$53.00	1 hour	\$53.00	\$750.00	\$750.00	\$909.00
<b>HBLDS3</b>	\$185.00	\$53.00	1 hour	\$53.00	\$750.00	\$750.00	\$988.00

### MotorQuick® Motor Changeout

Catalog Number	Total Material Cost	Labor Cost/ Hr	Downtime	Total Labor Cost	Downtime Cost/hr	Total Downtime Cost	Total Cost	Total Savings
<b>HBL1389MQ*</b>	\$299.00	\$53.00	20 minutes	\$17.67	\$750.00	\$250.00	\$566.67	<b>\$342.33</b>
<b>HBLDS3MQ*</b>	\$411.00	\$53.00	20 minutes	\$17.67	\$750.00	\$250.00	\$678.67	<b>\$309.33</b>

Note: \*MotorQuick catalog numbers are based on the average cost of the various designs.



**IP67**  
SUITABILITY

### Housing Design

- Thermoplastic Cover on Plated Steel Base
- NEMA 1 Enclosure
- Pre-wired with LINKOSITY® Components
- Crush and Impact Resistance of MC Cable



HBL1389MQ5

### Housing Design

- High Impact PBT Enclosure
- Type 4X Enclosure
- Permanent Labelless Marking
- Lockable Handle to Meet OSHA Lockout/Tagout Regulations
- Cable Ratings: TC-ER, MTW, STOOW



HBLDS3MQ5

## MotorQuick® Disconnect Switches

Type 1 Non-Metallic Enclosure 30A 3 Pole 600V AC	Catalog Number	
HBL1389D with one pre-wired LINKOSITY® female receptacle (load side).	HBL1389MQR	
HBL1389D with 5 foot pre-wired LINKOSITY® female cable (load side).	HBL1389MQ5	
HBL1389D with one pre-wired LINKOSITY® male receptacle (line side) and one pre-wired LINKOSITY® female receptacle (load side).	HBL1389MQR2	
Type 4X Non-Metallic Labelless Enclosure 30A 3 Pole 600V AC	Catalog Number	
HBLDS3 with one pre-wired LINKOSITY® female receptacle (load side).	HBLDS3MQR	
HBLDS3 with 5 foot pre-wired LINKOSITY® female cable (load side).	HBLDS3MQ5	
HBLDS3 with one pre-wired LINKOSITY® male receptacle (line side) and one pre-wired LINKOSITY® female receptacle (load side).	HBLDS3MQR2	
Type 4X Stainless Steel Enclosure 30A 3 Pole 600V AC	Catalog Number	
	Sloped Top	Square Top
HBLDS3SS with one pre-wired LINKOSITY® female receptacle (load side).	HBLDS3SSRMQR	HBLDS3SSMQR
HBLDS3SS with 5 foot pre-wired LINKOSITY® female cable (load side).	HBLDS3SSRMQ5	HBLDS3SSMQ5
HBLDS3SS with one pre-wired LINKOSITY® male receptacle (line side) and one pre-wired LINKOSITY® female receptacle (load side).	HBLDS3SSRMQR2	HBLDS3SSMQR2



### Accessories

Description	Catalog Number
3P 4W LINKOSITY® male receptacle for installation on motor.	RM3004PA001
3P 4W LINKOSITY® female receptacle for installation in switch.	RF3004PA001
3P 4W LINKOSITY® double ended (male/female) 5-50 foot cable.	PH3004PAxxx*
3P 4W LINKOSITY® single ended (female) 5-50 foot cable.	PF3004PAxxx*
Cord connector, 3/4 in. NPT .63-.75 in. (16.0-19.1) diameter.	SHC1037CR
Lock-on cover for LINKOSITY® connections.	PH2030C

Note: \*Cables available from 5-50 feet in 5 foot increments. To purchase larger cable, replace the **xxx** with the required length in feet. (Examples: PH3004PA005 = 5 foot cable, PH3004PA050 = 50 foot cable.)

### Sample Set Up

(1) HBLDS3MQR + (1) PH3004PAxxx + (1) RM3004PA001 = Total Set Up\*\*

Note: \*\* Retrofit parts available for pre-existing disconnect switch installations. Please consult factory for availability.



PH2030C

# Switched Disconnects and Enclosures

## Dimensions

### Type 1

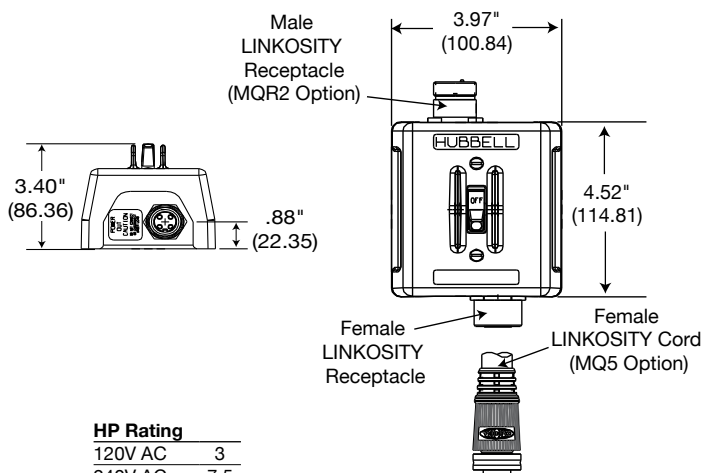

HP Rating	
120V AC	3
240V AC	7.5
480V AC	15
600V AC	20

### Type 4X

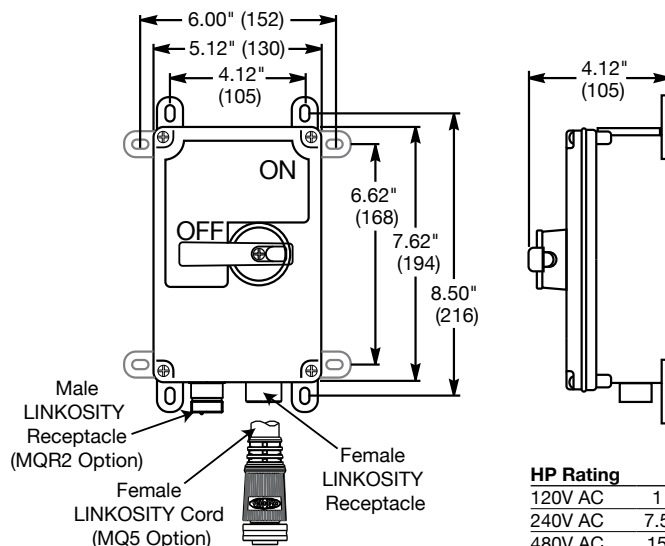

HP Rating	
120V AC	1
240V AC	7.5
480V AC	15
600V AC	15

## Specifications

### Type 1

### Type 4X

#### Electrical Performance

Dielectric Voltage	2,200V AC minimum for 1 minute.	2,200V AC minimum for 1 minute.
Electrical Life	6,000 cycles with load.	6,000 cycles with load.
Max. Working Voltage	600V AC RMS.	600V AC RMS.
Short Circuit Current Ratings (SCCR): (Motor Disconnect)	10,000 RMS symmetrical amps when tested with 60A max J fuses.	<ul style="list-style-type: none"> <li>30: Suitable for use on a circuit capable of delivering not more than 10kA RMS symmetrical, 600V AC max.</li> </ul>
Short Circuit Current Ratings (SCCR): (Motor Controller)	10,000 RMS symmetrical amps when tested with 125A RK5 fuses.	<ul style="list-style-type: none"> <li>30A: Suitable for use on a circuit capable of delivering not more than 65kA RMS symmetrical, 600V AC max. when protected by Class J fuses rated 30A max.</li> </ul>

#### Mechanical

Mechanical Life	10,000 minimum cycles.	10,000 minimum cycles.
Terminal Accommodations	Amps AWG Min. AWG Max.	Amps AWG Min. AWG Max.
Terminal Torque	30 20 inch pounds	30 20 inch pounds
Impact Resistance	— — —	UL746C

#### Environmental

Flammability	UL94HB/V-0.	UL94-5VA and V0 Classification.
Operating Temp.	Max. continuous 60°C Min. continuous w/o impact -40°C	Max. continuous 75°C Min. continuous -40°C

#### Listings

UL 508	Industrial Control Equipment File #E36355	Industrial Control Equipment File #E36355
--------	---	---

## LINKOSITY® Connection

#### Certifications

Connecting Components	Listed to UL 2238 and UL 50E.
-----------------------	-------------------------------

#### Electrical Performance

Voltage	Up to 600V AC.
Amperage	Up to 30A.

#### Environmental

Connectivity System Components	
Moisture Resistance	UL Type 4, 4X, 12 and 13.
Ingress Protection	IP67 Suitability.
Flammability	UL94HB cables / UL94V-0 receptacles.

#### Materials

##### Connectivity System Components

Contact Carrier	Nylon 6/6, white.
Contact Materials	Pins - brass. Sockets - leaded nickel copper w/ stainless steel sleeve.
Contact Plating	Hard gold over palladium/nickel.
Overmold Material	Glass filled polyurethane, gray.
Coupling Hardware	Nickel plated brass.
Cable (16 AWG and Up)	UL 600V Type TC-ER, MTW 90°C or STOOW 600V 105°C.

Dimensions in Inches (mm)

# Switched Disconnects and Enclosures

## Features and Benefits

### Circuit-Lock® 200A Disconnect Switches

Hubbell's 200A Disconnect Switches are the latest addition to the Circuit-Lock® family of switched enclosures. The enclosures are designed to withstand harsh environments with exposure to water, chemicals, oils and frequent washdowns. Available in non-metallic or stainless steel, the enclosures are UL Listed Type 4X and 12.

- UL 98 Rated Switch
- Non-Metallic and Stainless Steel
- Type 4X, 12
- Accepts up to 2 Auxiliary Contacts
- Highly Visible Red Rotary Handle
- OSHA Compliant Lockout/Tagout Handle
- Unable to Open the Cover when ON; Cover Locked when Energized
- 200kA SCCR Rating when Protected by a Class "J" Fuse



*Designed to Withstand Harsh Environments*

HBLDS20

HBLDS20SS

### Circuit-Lock® 200A Disconnect Switches

Description	Catalog Number
200A non-metallic disconnect.	<b>HBLDS20</b>
200A stainless steel disconnect.	<b>HBLDS20SS</b>
N/O auxiliary contact - "Break Before Main".	<b>HBLAC200</b>
200A replacement switch.	<b>HBLDS20RS</b>
200A replacement handle.	<b>HBL200HDL</b>

### Materials - 200A Non-Metallic

Description	Material	Finish
Enclosure	FR Polyester	—
Handle	Plastic	Red/Yellow
Switch	Plastic	—
Backplate	12 Ga. Aluminum	None
Terminals	Aluminum	Tin Plated
Fasteners	Steel	Zinc Plated

### Materials - 200A Stainless Steel

Description	Material	Finish
Enclosure	14 Ga. 304 SST	Smooth Grain
Handle	Plastic	Red/Yellow
Switch	Plastic	—
Backplate	14 Ga. 304 SST	304 Ann 2B
Terminals	Aluminum	Tin Plated
Fasteners	Steel	Zinc Plated
Mounting Feet	304 SST	—

## Dimensions

### Non-Metallic

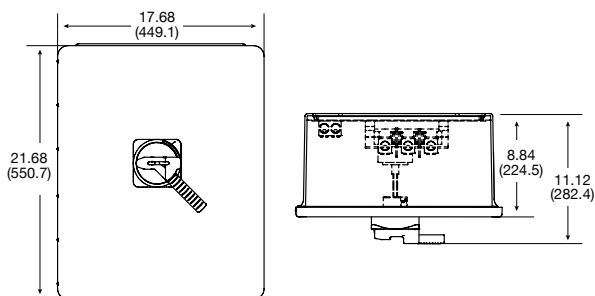

### Stainless Steel

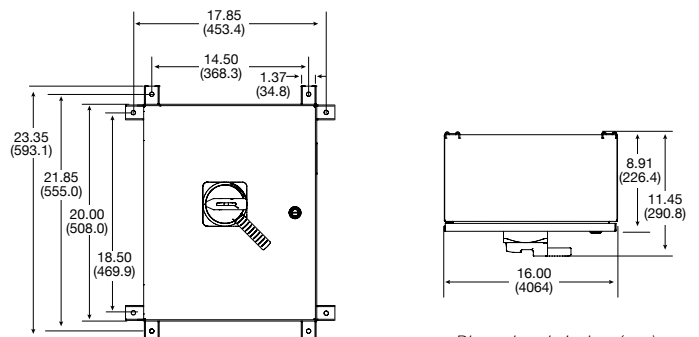

Dimensions in Inches (mm)

# Switched Disconnects and Enclosures

## Features and Benefits

### Circuit-Lock® 30 and 60 Ampere Fused Disconnect Switches

The Circuit-Lock Fused Disconnect Switch provides fused switched control of a directly wired load. The switch cannot be turned ON unless the enclosure cover is closed. The fuses cannot be accessed until the switch is turned OFF. The fuse holder accepts Class "J" fuses. This enclosure is non-metallic and is listed for Outdoor/Indoor (Type 4X Wash down, Corrosion resistant). The handle can be locked in the OFF position to comply with OSHA Lockout/Tagout regulations.

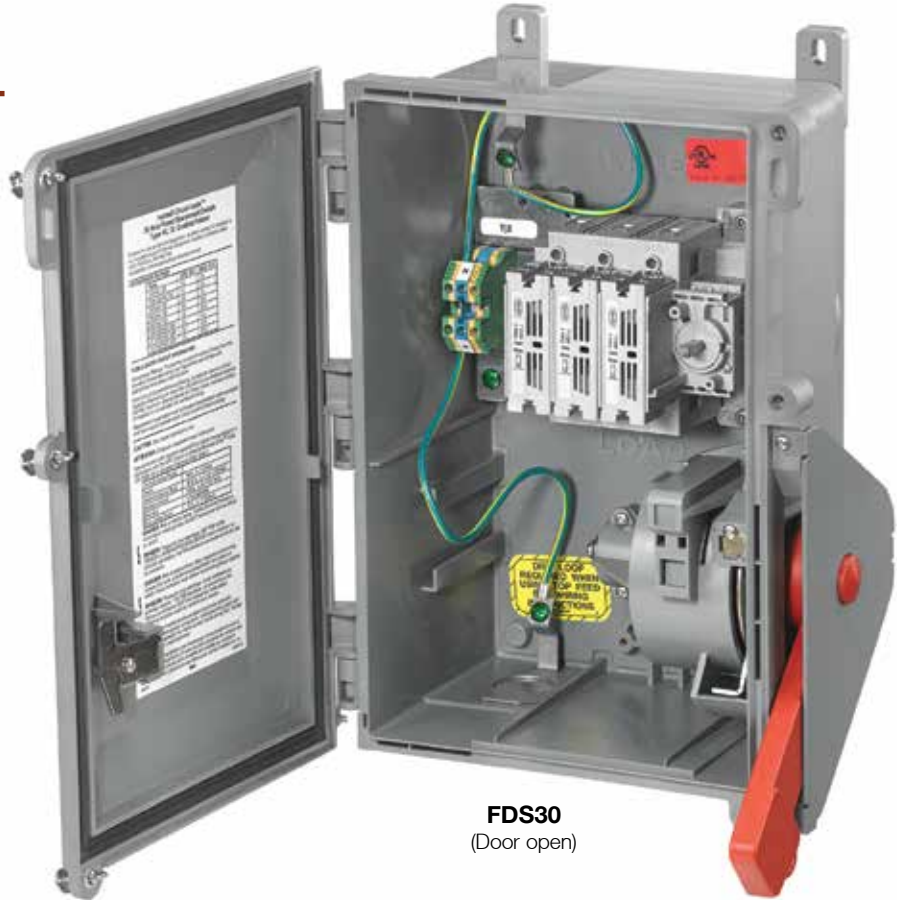

**FDS30**  
(Door open)



#### Housing Design

- Non-metallic enclosure meets UL 50E Type 4X (watertight) 12 (dust-tight) and IP66 suitability requirements
- Enclosure is molded of rugged PBT to resist abuse, corrosion and enhance safety
- Stainless steel ¼ in. turn door fasteners for quick, easy access to fuses.

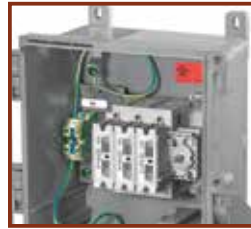

#### Internal Design

- Fused disconnect switches accept Class "J" fuses
- Internal frame automatically bonds all grounds
- Captured neoprene gasket provides a watertight seal between cover and base



#### Safety

- Enclosure door can be locked to prevent unauthorized access. Additionally, if the switch is ON, the door cannot be opened
- Lockable highly visible red handle to meet OSHA lockout/tagout
- Safety interlocked fuse access door



#### Interior

- Removable door for ease of wiring and installation
- Three molded-in conduit drill points are located on the top, bottom and back surface of enclosure. Conduit hub provided: 30A 1 in. NPT, 60A 1¼ in. NPT



#### Installation

- Conduit hub and adjustable mounting feet are supplied with each Circuit-Lock® fused disconnect switch.
- Adjustable mounting feet (4) can be mounted in any of three positions for ease of installation



#### Switch

- Compact Fused Disconnect Switch accepts Class "J" fuses. Fuse holders are top mounted for easy access. The switch accepts auxiliary contacts for control circuit applications including the ON/OFF control of remote pilot lights or signal for programmable controllers.

**IP66**  
SUITABILITY

## 30 and 60 Amp Fused Disconnect Switches

Description	Catalog Number
30A Circuit-Lock fused disconnect switch.	<b>FDS30*</b>
60A Circuit-Lock fused disconnect switch.	<b>FDS60*</b>

Note: \*Class "J" fuses not included.



**FDS30**

## Auxiliary Contacts

Description	Black Style Switch Catalog Number	Gray Style Switch Catalog Number
Auxiliary contact, normally open, A600 pilot duty, break before break.	<b>ACFSNO</b>	<b>HBLACFSNO</b>
Auxiliary contact, normally closed, A600 pilot duty, break before break.	<b>ACFSNC</b>	<b>HBLACFSNC</b>

Note: Auxiliary contacts are specific to the style switch noted and are NOT interchangeable.

## Replacement Switches

Description	Gray Style Switch Catalog Number
For 30A fused switches.	<b>HBL30MIFRS</b>
For 60A fused switches. Gray Style switch will retro fit Black Style switch.	<b>HBL60MIFRS</b>



**HBLACFSNO**

**HBL30MIFRS**

## Watertight Closure Plug Kits

Description	Catalog Number
For 30A Circuit-Lock® unfused and fused Pin and Sleeve mechanical interlocks.	<b>MICPK30</b>
For 60 and 100A Circuit-Lock® unfused and fused Pin and Sleeve mechanical interlocks.	<b>MICPK60</b>

## Black Style Switch



**ACFSNO**

## Replacement Mounting Feet

Description	Catalog Number
Replacement mounting feet and screws for 30 and 60A fused mechanical interlocks.	<b>HBLRFT2<sup>^</sup></b>

Note: 30A Units supplied with two 1 in. NPT raintight conduit fittings.  
60A Units supplied with two 1 1/4 in. NPT raintight conduit fittings.  
<sup>^</sup> Package of 10 feet and 10 screws.



**HBLRFT2**



**MICPK30**

## Dimensions

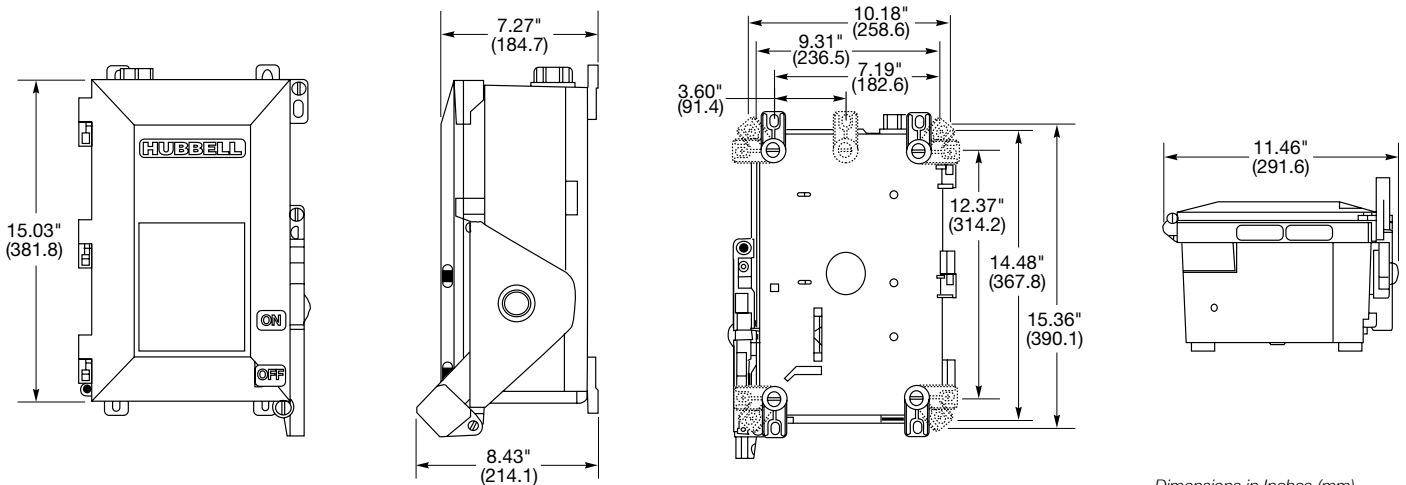

Dimensions in Inches (mm)

# Switched Disconnects and Enclosures

## Horsepower Ratings

Ratings	Volts	Standard HP	Maximum HP*	Catalog Number
30A	120V AC	0.5	2	<b>FDS30</b>
600V AC	208-240V AC	1.5	3	
Max.	3Ø 240V AC	3	7.5	
	3Ø 480V AC	5	15	
	3Ø 600V AC	7.5	20	
	3Ø Y 120/208V AC	3	5	
	3Ø Y 277/480V AC	5	15	
	3Ø Y 347/600V AC	7.5	20	
60A	120V AC	1.5	3	<b>FDS60</b>
600V AC	208-240V AC	3	7.5	
Max.	3Ø 240V AC	7.5	15	
	3Ø 480V AC	15	30	
	3Ø 600V AC	15	50	
	3Ø Y 120/208V AC	7.5	15	
	3Ø Y 277/480V AC	15	30	
	3Ø Y 347/600V AC	15	40	

Note: \*Requires time delay fuses.

## Fuse and Short Circuit Information

Horsepower Ratings	The starting current of motors of more than the standard horsepower rating may require the use of fuses with appropriate time-delay characteristics.
Short Circuit Withstand Rating	Suitable for use on a circuit capable of delivering not more than 200,000 RMS symmetrical amperes at the voltage rating of receptacle when protected by Class "J" fuses.

Note: Replacement fused switch must be the same type Hubbell switch as original and have equal or greater short circuit current withstand rating.

## Circuit-Lock® Fused Disconnect Switch

### Specifications

Moisture Resistance	Indoor and Outdoor – Type 4X (Wash down, Corrosion resistant); Indoor – Type 12 (Dust-tight, Falling Dirt, Noncorrosive Liquids).
Flammability	UL94-5VA and V0 Classification.
Operating Temperature	Maximum Continuous 75°C; Minimum Continuous -40°C without impact.
UV Resistance	All materials are UV stabilized.
Dielectric Voltage	Withstands 3000V AC minimum.
Max. Working Voltage	600V AC RMS.
Impact Resistance	In accordance with UL 746C.
Terminal Identification	In accordance with UL, CSA and international conventions.
Product Identification	Identification and ratings are part of external label.
Mounting	External fully adjustable feet.
Fuse Types	UL Listed, Class "J"; CSA Certified, HRCI-J.

### Materials

Part	Material
Base	PBT
Door	PBT
Handle	PBT
Conduit Hub	Zinc, 30A Fused – 1 in., 60A Fused – 1¼ in.
Enclosure Gasket	Neoprene
Shaft	Brass
Shaft Seal	Neoprene
Frame	Galvanized Steel
Ground Plate	Galvanized Steel
Enclosure Screws	Stainless Steel 300 Series



# Switched Disconnects and Enclosures

## Ratings Quick Reference Guide

### Circuit-Lock® Switched Enclosures

Amp Description	Phase	Poles	HP				Catalog Number
			120	240	480	600	
30 TYPE 1 Non-Metallic	3	3	3	7.5	15	20	<b>HBL1389MQR</b>
TYPE 1 Non-Metallic	3	3	3	7.5	15	20	<b>HBL1389MQ5</b>
TYPE 1 Non-Metallic	3	3	3	7.5	15	20	<b>HBL1389MQR2</b>
NEMA 1 Aluminum	1	2	2	5	10	15	<b>HBL1372D</b>
NEMA 1 Aluminum	3	3	3	7.5	15	20	<b>HBL1379D</b>
NEMA 1 Non-Metallic	1	2	2	5	10	15	<b>HBL1392D</b>
NEMA 1 Non-Metallic	3	3	3	7.5	15	20	<b>HBL1389D</b>
NEMA 3/3R Non-Metallic	1	2	2	5	10	15	<b>HBL13R22D</b>
NEMA 3/3R Non-Metallic	3	3	3	7.5	15	20	<b>HBL13R23D</b>
NEMA 3R Die Cast Aluminum	1	2	2	5	10	15	<b>HBL13R12D</b>
NEMA 3R Die Cast Aluminum	3	3	3	7.5	15	20	<b>HBL13R13D</b>
NEMA 3R Aluminum	1	2	2	5	10	15	<b>HBL13R92D</b>
NEMA 3R Aluminum	3	3	3	7.5	15	20	<b>HBL13R89D</b>
IP69k TYPE 4X Labelless Non-Metallic	3	3	1	7.5	15	15	<b>HBLDS3</b>
IP69k TYPE 4X Labelless Non-Metallic	3	3	1	7.5	15	15	<b>HBLDS3AC</b>
IP69k TYPE 4X Labelless Non-Metallic	3	3	1	7.5	15	15	<b>HBLDS3NK</b>
IP69k TYPE 4X Labelless Non-Metallic	3	3	1	7.5	15	15	<b>HBLDS3ACNK</b>
IP69k TYPE 4X Labelless Non-Metallic	3	3	1	5	10	10	<b>HBLDS33ACNK</b>
TYPE 4X Labelless Non-Metallic	3	3	1	7.5	15	15	<b>HBLDS3MQR</b>
TYPE 4X Labelless Non-Metallic	3	3	1	7.5	15	15	<b>HBLDS3MQ5</b>
TYPE 4X Labelless Non-Metallic	3	3	1	7.5	15	15	<b>HBLDS3MQR2</b>
IP69k TYPE 4X Stainless Steel	3	3	1	7.5	15	15	<b>HBLDS3SS</b>
IP69k TYPE 4X Stainless Steel	3	3	1	7.5	15	15	<b>HBLDS3SSAC</b>
IP69k TYPE 4X Stainless Steel	3	3	1	7.5	15	15	<b>HBLDS3SSVFD</b>
TYPE 4X Stainless Steel	3	3	1	7.5	15	15	<b>HBLDS3SSMQR</b>
TYPE 4X Stainless Steel	3	3	1	7.5	15	15	<b>HBLDS3SSMQ5</b>
IP69k TYPE 4X, 12 and IP69k Sloped, SS	1	3	1	3	5	15	<b>HBLDS3SSR</b>
IP69k TYPE 4X, 12 and IP69k Sloped, SS	1	3	1	3	5	15	<b>HBLDS3SSR2K</b>
IP69k TYPE 4X, 12 and IP69k Sloped, SS	1	3	1	3	5	15	<b>HBLDS3SSRVFD</b>
IP69k TYPE 4X, 12 and IP69k Sloped, SS	1	3	1	3	5	15	<b>HBLDS3SSRAC</b>
IP69k TYPE 4X, 12 and IP69k Sloped, SS	1	3	1	3	5	15	<b>HBLDS3SSRMQR</b>
IP69k TYPE 4X, 12 and IP69k Sloped, SS	1	3	1	3	5	15	<b>HBLDS3SSRMQ5</b>
IP69k TYPE 4X, 12 and IP69k Sloped, SS	1	3	1	3	5	15	<b>HBLDS3SSRMQR2</b>
TYPE 4X Non-Metallic Fused Disconnect	3	3	1	7.5	15	20	<b>FDS30</b>
NEMA 4X Stainless Steel	3	3	3	7.5	15	20	<b>HBL13S33D</b>
NEMA 4X Non-Metallic	3	3	3	7.5	15	20	<b>HBL13X33D</b>
60 NEMA 3R Aluminum	1	2	—	10	15	20	<b>HBL16R92D</b>
NEMA 3R Aluminum	3	3	—	10	25	30	<b>HBL16R93D</b>
IP69k TYPE 4X Non-Metallic	3	3	7.5	30	50	50	<b>HBLDS6</b>
IP69k TYPE 4X Non-Metallic	3	3	7.5	30	50	50	<b>HBLDS6AC</b>
IP69k TYPE 4X Stainless Steel	3	3	7.5	30	50	50	<b>HBLDS6SS</b>
IP69k TYPE 4X Stainless Steel	3	3	7.5	30	50	50	<b>HBLDS6SSAC</b>
IP69k TYPE 4X, 12 and IP69k Sloped, SS	3	3	7.5	30	50	50	<b>HBLDS6SSR</b>
IP69k TYPE 4X, 12 and IP69k Sloped, SS	3	3	7.5	30	50	50	<b>HBLDS6SSRVFD</b>
IP69k TYPE 4X, 12 and IP69k Sloped, SS	3	3	7.5	30	50	50	<b>HBLDS6SSRAC</b>
TYPE 4X Non-Metallic Fused Disconnect	3	3	3	15	30	40	<b>FDS60</b>
NEMA 4X Stainless Steel	3	3	—	10	25	30	<b>HBL16S63D</b>
NEMA 4X Non-Metallic	3	3	—	10	25	30	<b>HBL16X63D</b>
100 IP69k TYPE 4X Non-Metallic	3	3	7.5	30	50	50	<b>HBLDS10</b>
IP69k TYPE 4X Non-Metallic	3	3	7.5	30	50	50	<b>HBLDS10AC</b>
IP69k TYPE 4X Stainless Steel	3	3	7.5	30	50	50	<b>HBLDS10SS</b>
IP69k TYPE 4X Stainless Steel	3	3	7.5	30	50	50	<b>HBLDS10SSAC</b>
IP69k TYPE 4X, 12 and IP69k Sloped, SS	3	3	7.5	30	50	50	<b>HBLDS10SSR</b>
IP69k TYPE 4X, 12 and IP69k Sloped, SS	3	3	7.5	30	50	50	<b>HBLDS10SSRVFD</b>
IP69k TYPE 4X, 12 and IP69k Sloped, SS	3	3	7.5	30	50	50	<b>HBLDS10SSRAC</b>
200 Type 4X, 12 Non-Metallic			10	75	150	200	<b>HBLDS20</b>
Type 4X, 12 Stainless Steel			10	75	150	200	<b>HBLDS20SS</b>

Note: HP ratings apply to Jog and LED versions.



HBL1379D



HBL1389D



HBL1392D



HBL13R22D



HBLDS3



FDS30



HBLDS3P



HBLDS3J



HBLDS3MQR



HBLDS3MQ5



HBLDS3SS



HBLDS3SSR



HBLDS20



HBLDS20SS

## Features and Benefits

### Hazardous Location Non-Fused Disconnect Switches

Hubbell's hazardous location line of non-fused disconnect switches are typically used for applications with the presence of flammable gasses or vapors, ignitable dusts and fibers. They are also suitable for use in outdoor or indoor damp, wet and dirty locations or in areas where frequent wash downs, heavy rain, or water spray routinely occurs. These switches are compact in size to reduce cost and make it easier to position on the wall or piece of equipment. The enclosures are made of copper-free aluminum and have a polyester/epoxy finish to prevent corrosion. The highly visible handles can be locked out to comply with OSHA Lockout/Tagout regulations.

Class I, Div. 1 & 2, Groups B,C,D

Class I, Zones 1 & 2, Groups IIB+ H2, IIA

Class II, Div. 1 & 2, Groups E,F,G

Class III, NEMA 3, 4, 4X, 7(B,C,D), 9(E,F,G)

### Applications

- Grain manufacturing and storage
- Industrial chemical and gas manufacturing
- Petroleum refining
- Fertilizer manufacturing
- Vehicle repair/paint shops
- Coal mining
- Cotton and fabric mills



HBLB7NFD13A



HBLB7NFD26A



#### Housing Design

- Copper-free aluminum construction with electrostatically applied polyester/epoxy finish to prevent corrosion
- Compact NEMA 4X enclosure and footprint allows easy installation in tight locations
- Top and bottom drilled and tapped conduit entrances



#### Internal Design

- Gasketed flange with O-ring located inside bolt circle to seal out moisture
- Bodies have top and bottom drilled and tapped conduit entrances for power connection



#### Safety

- Lockable handle to meet OSHA Lockout/Tagout regulations
- For use as motor disconnects

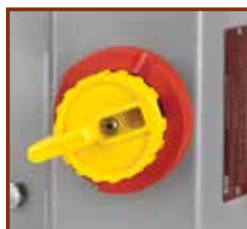

#### Safety

- Lockable handle to meet OSHA Lockout/Tagout regulations
- Large visible rotary handle with "ON-OFF" indicator allows a quick means of disconnecting power
- For use as motor disconnects



#### Installation

- Fewer cover bolts reduces installation and maintenance time
- Removable ductile mounting lugs adjust to irregular mounting surfaces
- 316 Stainless steel bolts



#### Switch

- Disconnects contain UL98 certified switch
- MI include UL508/UL60947 disconnect switch
- Optional to add one (1) N/O "Break Before Main Break" auxiliary contact

## Standard Materials/Finish

- Enclosures: Copper-free aluminum (less than 4/10 of 1% copper content)
- Cover Bolts: 316 Stainless Steel
- O-Ring Gasket: Silicone
- Finish: Grey Powder Polyester painted exterior, electrostatically applied
- Ratings: 600V AC, 230V DC 30–100 Amp
- Optimal to include up to one (1) N/O “Break Before Main Break” auxiliary contact



## Unfused Hazardous Location Disconnect Switches

Description	30 Amp	60 Amp	100 Amp
3 Pole disconnect switch.	<b>HBLB7NFD13A</b>	<b>HBLB7NFD26A</b>	<b>HBLB7NFD21A</b>
3 Pole disconnect switch with auxiliary contact.	<b>HBLB7NFD13AA</b>	<b>HBLB7NFD26AA</b>	<b>HBLB7NFD21AA</b>

## Disconnect Horsepower Ratings

Switch Amps/Phase	Single Phase HP			Three Phase HP			DC HP	Terminal Wire Size	Conduit Sizes	Catalog Number
	120V AC	230V AC	208V AC	230V AC	480V AC	600V AC	230V DC			
30A / 3P	2	5	10	10	20	30	1	#14-10	1 NPT	<b>HBLB7NFD13A</b>
60A / 3P	3	7.5	20	20	40	40	10	#14-4	1½ NPT	<b>HBLB7NFD26A</b>
100A / 3P	5	15	25	30	50	50	20	#8-1	1½ NPT	<b>HBLB7NFD21A</b>

## Dimensions

	Outside Box			Inside Box				Mounting Dimensions			
	A	B	C	D	E	F	G	H	I	J	K
30 Amp	5¾	8½ <sub>16</sub>	6 <sup>5</sup> / <sub>16</sub>	3 <sup>5</sup> / <sub>8</sub>	5 <sup>13</sup> / <sub>16</sub>	5 <sup>1</sup> / <sub>16</sub>	3 <sup>1</sup> / <sub>8</sub>	8 <sup>1</sup> / <sub>8</sub>	–	–	1¼
60 & 100 Amp	8 <sup>1</sup> / <sub>8</sub>	13 <sup>1</sup> / <sub>16</sub>	7 <sup>13</sup> / <sub>16</sub>	4¼	9 <sup>9</sup> / <sub>16</sub>	6 <sup>5</sup> / <sub>16</sub>	2½	11 <sup>1</sup> / <sub>8</sub>	6 <sup>3</sup> / <sub>8</sub>	7½	1 <sup>13</sup> / <sub>16</sub>

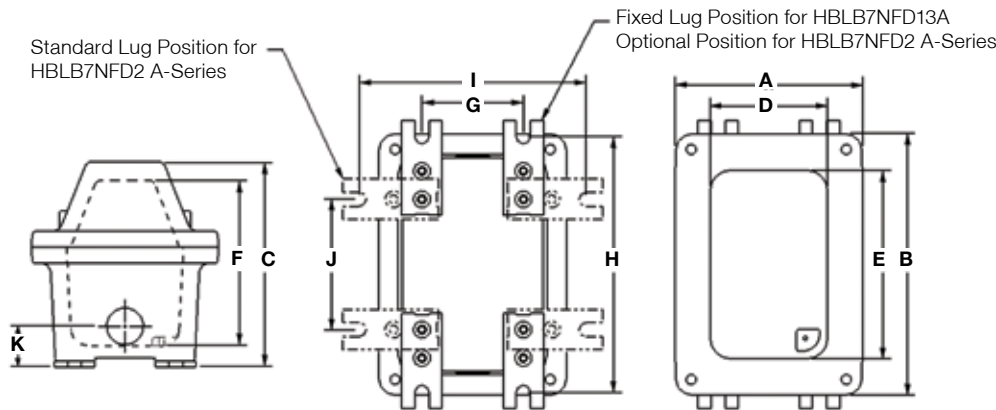

## Non-Fused UL1686 Mechanical Interlocks and Plugs

Amp	Circuit	Mechanical Interlock	Metallic Plug	Insulgrip Plug
30 Amp	2W 3P	<b>HBLVSQ3023</b>	<b>HBLVP3385</b>	<b>HBL330PS2W</b>
600V AC	3W 4P	<b>HBLVSQ3034</b>	<b>HBLVP3485</b>	<b>HBL430PS2W</b>
60 AMP	2W 3P	<b>HBLVSQ6023</b>	<b>HBLVP6385</b>	<b>HBL360PS2W</b>
600V AC	3W 4P	<b>HBLVSQ6034</b>	<b>HBLVP6485</b>	<b>HBL460PS2W</b>

Note: Early break contact comes standard with mechanical interlocks.

HBLVSQ 30 Amp models come standard with 1 inch drilled and tapped conduit openings top and bottom plus two 1 inch x ¼ inch reducers and one ¼ inch close-up plug for maximum flexibility. 60 amp models come with one 1½ inch opening on top and bottom and one 1½ inch close-up plug.

See page G-44 for Dimensions on Mechanical Interlocks and Plugs.

## Horsepower Ratings (VAC)\*

Amp	Circuit	120	240	480	600	Catalog Number
30 Amp	1Ø	2	5	10	15	<b>HBLVSQ3023</b>
	3Ø	3	7.5	15	20	<b>HBLVSQ3034</b>
60 Amp	1Ø	–	10	15	20	<b>HBLVSQ6023</b>
	3Ø	–	10	25	30	<b>HBLVSQ6034</b>

Note: \*Internal switch only.



Dimensions in Inches (mm)

# Switched Disconnects and Enclosures

## Features and Benefits

### AC Manual Toggle Controllers/Disconnects

The most complete offering of Circuit-Lock® controllers rated “Suitable as Motor Disconnect” with top horsepower and high amperage ratings in such a compact device.



30A, 40A and 50A



60A and 85A



#### Housing Design

- Thermoset body provides high resistance to electrical arc tracking
- Withstands high temperatures
- Excellent dimensional stability
- Superior dielectric strength



#### Internal Design

- Strong ON/OFF action with quick-make, slow break operation
- Provides long-life reliability
- 10,000 Amp high fault short circuit withstand rating



#### Safety

- Optional Side Finger Guards for close wall applications and finger safe environments
- For 30A, 40A and 50A controllers
- Recessed wiring wells makes it finger safe environment



#### Contacts

- Four large silver alloy contacts per pole has excellent conductivity with maximum longevity
- 100% Copper contact arm has high heat management and reliability



#### Installation

- #10 Brass terminal screw with clamping plate for secure back or side wiring (30A only)
- Front and back wiring steel screws and copper terminals



#### Switch

- Lubrication-free controller with continued ON/OFF cycling even in harsh, dust and high heat environments

# Switched Disconnects and Enclosures

## 600V AC Manual Toggle Controllers/Disconnects

For use in almost any industrial environment. Ideal component switch for motor control and as a disconnect. Toggle controllers can be built into equipment and enclosures for either box or panel-mount installation.

Amp	Poles	ToggleType	Wire	HP Rating				Catalog Number
				120V AC 1Ø	240V AC 3Ø	480V AC 3Ø	600V AC 3Ø	
30	2	Standard	Back/Side	2	5	10	15	<b>HBL7832D</b>
	2	Short	Back/Side	2	5	10	15	<b>HBL7832DS</b>
	2	Standard	Back/Side	2	5	10	15	<b>HBL7832DX</b>
	3	Standard	Back/Side	3	7.5	15	20	<b>HBL7810D</b>
	3	Short	Back/Side	3	7.5	15	20	<b>HBL7810DS</b>
40	2	Standard	Side	2	5	10	15	<b>HBL7842D</b>
	3	Standard	Side	3	7.5	15	20	<b>HBL7843D</b>
50	2	Standard	Side	2	5	10	15	<b>HBL7852D</b>
	3	Standard	Side	3	7.5	15	25	<b>HBL7853D</b>
60	2	Standard	Back	—	10	15	20	<b>HBL7862D</b>
	3	Standard	Back	—	10	25	30	<b>HBL7863D</b>
	2	Standard	Front	—	10	15	20	<b>HBL7862FWD</b>
	3	Standard	Front	—	10	25	30	<b>HBL7863FWD</b>
85	2	Standard	Back	—	10	15	20	<b>HBL7882D</b>
	3	Standard	Back	—	10	25	40	<b>HBL7883D</b>
Optional Side Guard, for close wall applications and finger safe environments.								<b>HBLFG30*</b>

Note: \*For 30A, 40A and 50A controllers.



## Specifications

Electrical Performance		
Dielectric Voltage	Min. 2,200V AC minimum for 1 minute	
Electrical Life	Min. 6,000 Cycles at rated switch load	
Max. Working Voltage	600V AC RMS	
Switches	10,000 RMS	
Short Circuit	30A & 40A	60A max. when protected by J fuses
Withstand Rating	50A	50A max. when protected by J fuses
as Motor Disconnect	60A & 85A	80A max. when protected by J fuses
Short Circuit		
Withstand Rating	All Switches	125A max. RK5 fuses
as Motor Controller		
Mechanical		
Mechanical Life	Min. 10,000 minimum cycles	
Terminal	Switch Rating	AWG Max.
Accommodations	30A	#10
	40A & 50A	#8**
	60A & 85A	#4
Wire Type	Solid and stranded copper wire only.	
Terminal Torque	30A – 50A	20 inch pounds
Switch Rating	60A – 85A	25 inch pounds
Environmental		
Flammability	UL94HB/VO	
Operating Temp.	Max. 75°C	
	Min. -40°C continuous without impact	
Listings		
UL 508	Industrial Control File #E70402	
CSA-C22.2 No.14	LR-46186	

Note: \*\*Use listed certified ring terminal.

## Dimensions

### 30, 40 and 50 Amp Standard Toggles

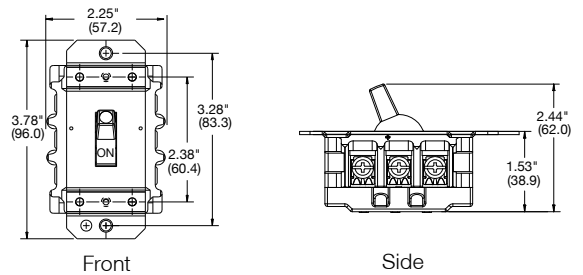

### 60 and 85 Amp Standard Toggles

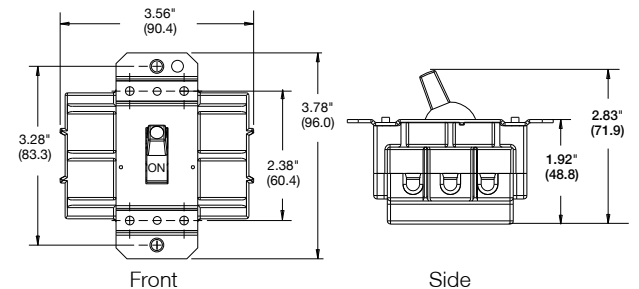

Dimensions in Inches (mm)

# Switched Disconnects and Enclosures

## NEMA 1 Disconnect Switches

### Housing Design

- Thermoplastic cover on a plated steel base
- Durable, non-conductive cover
- Wiring conduit knockouts
- ½" and ¾" NPT
- Top, bottom or back wire entry points
- Surface mount control
- Switch can be locked in the OFF position as a method of compliance with OSHA lockout/tagout



HBL1389D

### Housing Design

- All aluminum cover and base
- Base is pre-drilled for rear surface mounting
- Wiring conduit knockouts
- ½" and ¾" NPT
- Top, bottom or back wire entry points
- Surface mount control
- Switch can be locked in the OFF position as a method of compliance with OSHA lockout/tagout



HBL1379D



HBL1389D



HBL1379D



HBL1390



HBL1370

### Circuit-Lock® NEMA 1 Enclosures with Switch

Ideal for use in industrial environments, i.e. conveyer systems, industrial fans, etc.

Amp	Poles	Enclosure Material	HP Rating				Catalog Number
			120V AC 1Ø	240V AC 3Ø	480V AC 3Ø	600V AC 3Ø	
30	2	Thermoplastic	2	5	10	15	<b>HBL1392D</b>
30	3	Thermoplastic	3	7.5	15	20	<b>HBL1389D</b>
30	2	Aluminum	2	5	10	15	<b>HBL1372D</b>
30	3	Aluminum	3	7.5	15	20	<b>HBL1379D</b>

Note: See page F-21 for technical information.

### Circuit-Lock® NEMA 1 Enclosures without Switch

For use with switches shown on page F-21.

Description	Cover Material	Base Material	No. Equipment Grounds	Catalog Number
For use with 30A switch.	Thermoplastic	Steel	1	<b>HBL1390</b>
For use with 30A switch.	Aluminum	Aluminum	2	<b>HBL1370</b>

## Dimensions

### HBL1370, HBL1372D and HBL1379D

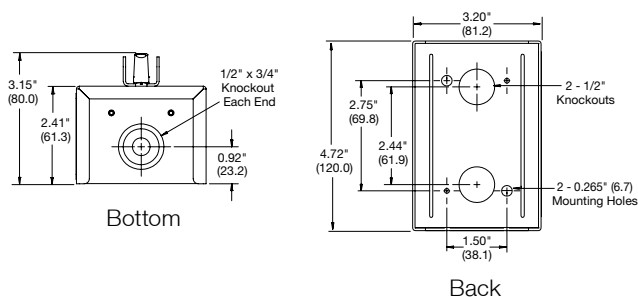

Dimensions in Inches (mm)

### HBL1390, HBL1389D and HBL1392D

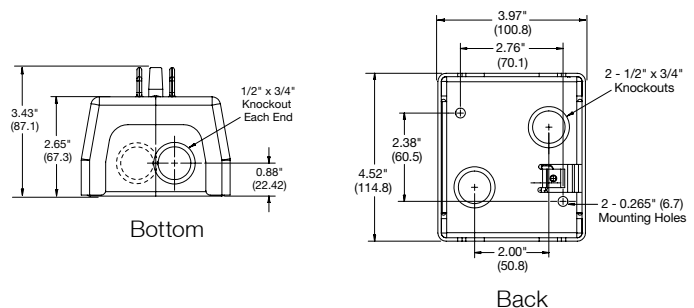

# Switched Disconnects and Enclosures

## Circuit-Lock® NEMA 3 and 3R Enclosures with Switch

Ideal for use on outdoor equipment.

Amp	Poles	Enclosure Material	Water Ingress	HP Rating				Catalog Number
				120V AC 1Ø	240V AC 3Ø	480V AC 3Ø	600V AC 3Ø	
30	2	Thermoplastic	3	2	5	10	15	<b>HBL13R22D</b>
30	3	Thermoplastic	3	3	7.5	15	20	<b>HBL13R23D</b>
30	2	Aluminum	3/3R	2	5	10	15	<b>HBL13R12D†</b>
30	3	Aluminum	3/3R	3	7.5	15	20	<b>HBL13R13D†</b>

Note: See page F-21 for technical information.

\*Drill weephole to alter from NEMA 3 to NEMA 3R.

†Equipped with HBLFG30 sidewall insulation barriers.



**HBL13R23D**

**HBL13R13D**

## Dimensions

### HBL13R22D and HBL13R23D

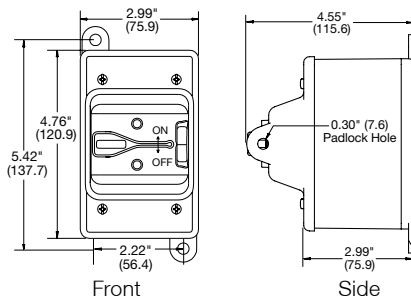

### HBL13R12D and HBL13R13D

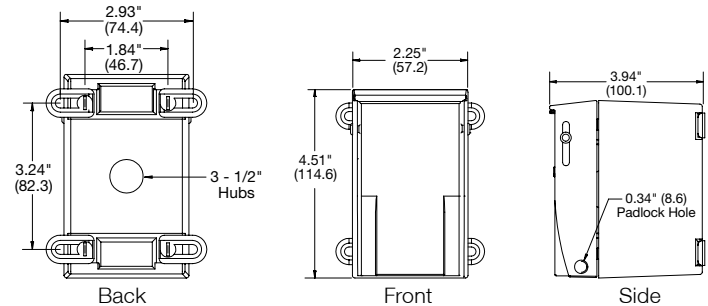

## Circuit-Lock® NEMA 3R Enclosures with Switch

Ideal for use in outdoor environments.

Amp	Poles	Enclosure Material	HP Rating				Catalog Number
			120V AC 1Ø	240V AC 3Ø	480V AC 3Ø	600V AC 3Ø	
30	2	Aluminum	2	5	10	15	<b>HBL13R92D</b>
30	3	Aluminum	3	7.5	15	20	<b>HBL13R89D</b>
60	2	Aluminum	—	10	15	20	<b>HBL16R92D</b>
60	3	Aluminum	—	10	25	30	<b>HBL16R93D</b>

Note: For switch specifications refer to page F-21.



**HBL13R89D**

**HBL16R93D**

## Circuit-Lock® NEMA 3R Enclosures without Switch

For use with switches shown on page F-21.

Description	Enclosure Material	Catalog Number
For use with 30A switch.	Aluminum	<b>HBL13R90</b>
For use with 60A switch.	Aluminum	<b>HBL16R90</b>

## Dimensions

### HBL13R90, HBL13R89D and HBL13R92D

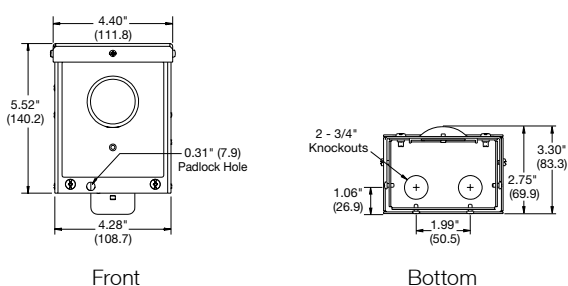

### HBL16R90, HBL16R92D and HBL16R93D

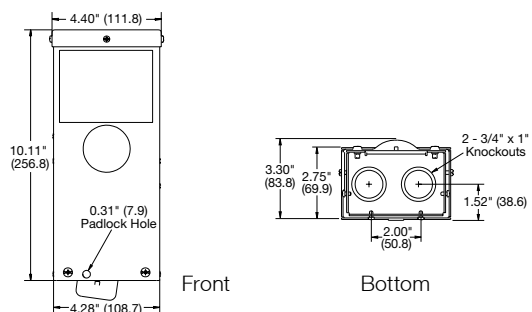

Dimensions in Inches (mm)

# Switched Disconnects and Enclosures

## 30A 600V AC Manual Motor Controllers, Double Pole

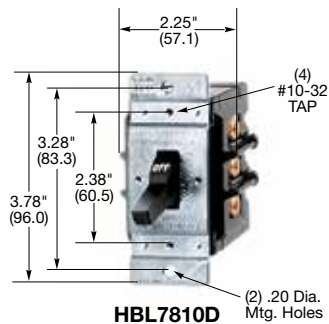

**HBL7810D**



**HBL1389D**

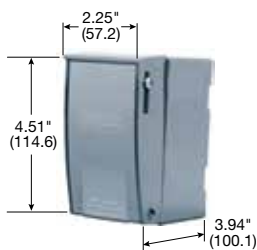

**HBL13R13D**

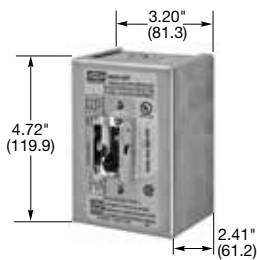

**HBL1379D**

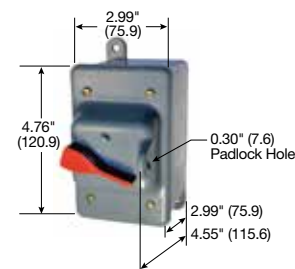

**HBL13R23D**



**HBL13R89D**



**HBL13S33D**

Description	Catalog Number
30A, double pole, single throw, AC manual motor controller, black nylon handle, side and back wired.	<b>HBL7832D</b>
30A, double pole, single throw, AC manual motor controller, black nylon handle, short toggle.	<b>HBL7832DS</b>
30A, double pole, single throw, AC manual motor controller. 50 piece bulk pack.	<b>HBL7832DX</b>
HBL7832D in HBL1390 Type 1 enclosure with non-metallic cover, ½ in. and ¼ in. knockouts on top, bottom and back of steel frame.	<b>HBL1392D</b>
HBL7832D in HBL1370 metal Type 1 enclosure.	<b>HBL1372D</b>
HBL7832D in NEMA 3R non-metallic enclosure.	<b>HBL13R22D</b>
HBL7832D in HBL13R90 metal Type 3R enclosure.	<b>HBL13R92D</b>
HBL7832D in NEMA 3R flip-lid enclosure.	<b>HBL13R12D</b>

Note: See page F-21 for technical information.

## 30A 600V AC Manual Motor Controllers, Three Pole

Description	Catalog Number
30A, three pole, single throw, AC manual motor controller, black nylon handle, side and back wired.	<b>HBL7810D</b>
30A, three pole, single throw, AC manual motor controller, black nylon handle, short toggle.	<b>HBL7810DS</b>
HBL7810D in HBL1390 Type 1 enclosure with non-metallic cover, ½ in. and ¼ in. knockouts on top, bottom and back of steel frame.	<b>HBL1389D</b>
HBL7810D in HBL1370 metal Type 1 enclosure.	<b>HBL1379D</b>
HBL7810D in NEMA 3R non-metallic enclosure.	<b>HBL13R23D</b>
HBL7810D in HBL13R90 metal Type 3R enclosure.	<b>HBL13R89D</b>
HBL7810D in NEMA 3R flip-lid enclosure.	<b>HBL13R13D</b>
30A, 600V, three pole, rotary controller in NEMA 4X stainless steel enclosure.	<b>HBL13S33D</b>
30A, 600V, three pole, rotary controller in NEMA 4X non-metallic enclosure.	<b>HBL13X33D</b>

Note: See page F-21 for technical information.

## Motor Rating

Product	120V AC	240V AC	480V AC	600V AC	Phase
30A Double Pole	2HP	5HP	10HP	15HP	1
30A Three Pole	3HP	7½HP	15HP	20HP	3
40A Double Pole	2HP	5HP	10HP	15HP	1
40A Three Pole	3HP	7½HP	15HP	20HP	3
50A Double Pole	2HP	5HP	10HP	15HP	1
50A Three Pole	3HP	7½HP	15HP	25HP	3
60A Double Pole	-	10HP	15HP	20HP	1
60A Three Pole	-	10HP	25HP	30HP	3
85A Double Pole	-	10HP	15HP	20HP	1
85A Three Pole	-	10HP	25HP	40HP	3

Dimensions in Inches (mm)



# Switched Disconnects and Enclosures

**IP44\***  
SUITABILITY

## 40A 600V AC Manual Motor Controllers

Description	Catalog Number
40A, double pole, single throw, AC manual motor controller, black nylon handle, side wired.	<b>HBL7842D</b>
40A, three pole, single throw, AC manual motor controller, black nylon handle, side wired.	<b>HBL7843D</b>

*Note: See page F-21 for technical information.*

## 50A 600V AC Manual Motor Controllers

Description	Catalog Number
50A, double pole, single throw, AC manual motor controller, black nylon handle, side wired.	<b>HBL7852D</b>
50A, three pole, single throw, AC manual motor controller, black nylon handle, side wired.	<b>HBL7853D</b>

*Note: See page F-21 for technical information.*

## 60A 600V AC Manual Motor Controllers

Description	Catalog Number
60A, double pole, single throw, AC manual motor controller, black nylon handle, back wired.	<b>HBL7862D</b>
Same as HBL7862D except front wired.	<b>HBL7862FWD</b>
HBL7862FWD in Type 3R enclosure.	<b>HBL16R92D</b>
60A, three pole, single throw, AC manual motor controller, black nylon handle, back wired.	<b>HBL7863D</b>
Same as HBL7863D except front wired.	<b>HBL7863FWD</b>
HBL7863FWD in a Type 3R enclosure.	<b>HBL16R93D</b>
60A, 600V, three pole, rotary controller in NEMA 4X stainless steel enclosure.	<b>HBL16S63D</b>
60A, 600V, three pole, rotary controller in NEMA 4X non-metallic enclosure.	<b>HBL16X63D</b>

*Note: See page F-21 for technical information.*

## 85A 600V AC Manual Motor Controllers

Description	Catalog Number
85A, double pole, single throw, AC manual motor controller, black nylon handle, back wired.	<b>HBL7882D</b>
85A, three pole, single throw, AC manual motor controller, black nylon handle, back wired.	<b>HBL7883D</b>

*Note: See page F-21 for technical information.*

## Motor Controller Accessories

Description	Catalog Number
Finger Guards, fit 30A, 40A and 50A controllers.	<b>HBLFG30</b>
Auxiliary Contacts, NO/Common/NC, for use in rotary switches only.	<b>HBLAUX</b>

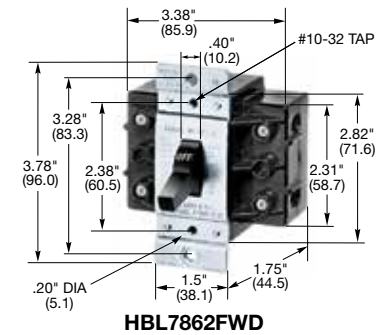
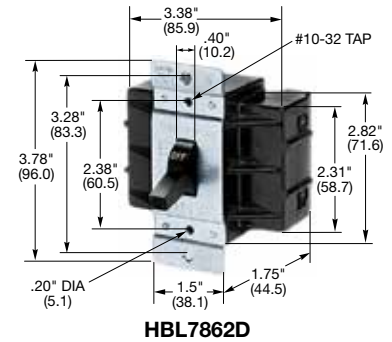

Dimensions in Inches (mm)

# Switched Disconnects and Enclosures

## NEMA 4X Disconnect Switches

### Housing Design

- Thermoplastic 4X Non-metallic enclosures
- Un-drilled case allows custom placement of wire entry
- Switch can be locked in the OFF position as a method of compliance with OSHA lockout/tagout



HBL13X33D

### Housing Design

- 304 Stainless steel enclosure chemical and corrosion resistant
- PBT handle and collar chemical and impact resistant
- Hinged cover with removable continuous pin
- Un-drilled case allows custom placement of wire entry
- Switch can be locked in the OFF position as a method of compliance with OSHA lockout/tagout



HBL13S33D



HBL13S33D  
(Door open)

### Interior Design

- Interlocking shaft and handle prevents cover removal when switch is ON
- Poured in closed cell neoprene gasket
- Up to 2 optional auxiliary contacts for PLCs and external indicators



## Circuit-Lock® NEMA 4X Enclosures with Switch and Accessories

Ideal for use in environments where wash-down is necessary, i.e. food processing, laboratories, etc.



HBL16S63D

HBL13X33D

Amp	Poles	Enclosure Material	HP Rating				Catalog Number
			120V AC 1Ø	240V AC 3Ø	480V AC 3Ø	600V AC 3Ø	
30	3	Stainless Steel	3	7.5	15	20	<b>HBL13S33D</b>
30	3	Non-Metallic	3	7.5	15	20	<b>HBL13X33D</b>
60	3	Stainless Steel	—	10	25	30	<b>HBL16S63D</b>
60	3	Non-Metallic	—	10	25	30	<b>HBL16X63D</b>
Finger Guard option for 30A switch.							<b>HBLFG30</b>
NO/Comon/NC auxiliary contact, 10A 120/250V AC for 30 and 60 Amp switches.							<b>HBLAUX</b>

## Dimensions

### HBL13S33D

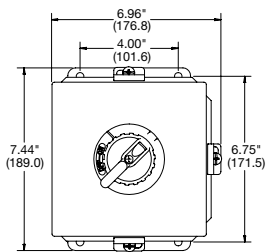

Front

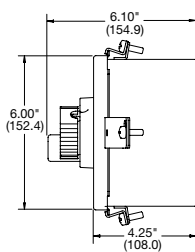

Side

### HBL16S63D

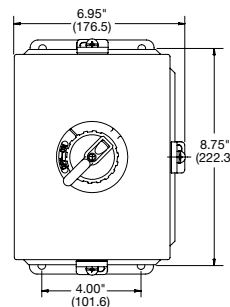

Front

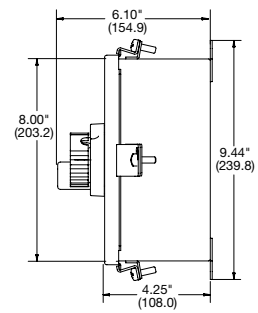

Side

Dimensions in Inches (mm)

**IP55**  
SUITABILITY

## CPB Series Compact Pendant Stations, Two Button, NEMA 4X

Description	Catalog Number
Single-speed normally open-normally closed without mechanical interlock.	<b>CPB20</b>
Single-speed with mechanical interlock between pushbuttons.	<b>CPB21</b>
Two-speed with mechanical interlock between pushbuttons.	<b>CPB22</b>

Note: Included with product: nylon cord grip and sealing washer (must be installed to achieve NEMA 4X rating).  
 Indication label pack. Cord dia. range .375-.625 in. (9.5-15.9)  
 Ambient temperatures: 25°F to 140°F (32°C to 60°C).  
 Typical applications: Package electric motor hoists. Remote control of machinery.



**CPB21**

### Wiring Diagram CPB2 Series

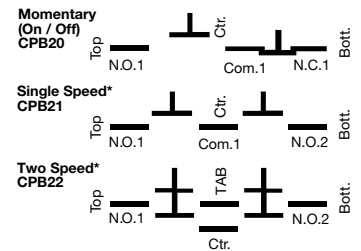

\*Mechanical "floating ball" interlock prevents activating both Pushbuttons simultaneously.

## Contact Ratings, CPB Series

Single-Speed	Voltage	Current
AC	120V	6A
35% PF	240V	3A
DC	125V	1.1A
IND	250V	.55A
Two-Speed	Voltage	Current
AC	120V	3A
35% PF	240V	1.5A

**IP44**  
SUITABILITY

## PBS Series Heavy Duty Pendant Pushbutton Stations, NEMA 3R

Description	Catalog Number
2 button, single speed.	<b>PBS2</b>
2 button, two speed.	<b>PBS22</b>
4 button, single speed.	<b>PBS4</b>
4 button, two speed.	<b>PBS42</b>
6 button, single speed.	<b>PBS6</b>
6 button, two speed.	<b>PBS62</b>
8 button, single speed.	<b>PBS8</b>
8 button, two speed.	<b>PBS82</b>



**PBS4**

**PBS6**

## Product Dimensions, PBS Series

Style	A	Approx. Wt. Assembled	Catalog Number
2 button	7.88" (200.0)	2.5 lbs	<b>PBS2</b>
4 button	13.69" (347.6)	4.5 lbs	<b>PBS4</b>
6 button	18.0" (457.2)	5.5 lbs	<b>PBS6</b>
8 button	22.31" (566.7)	7.5 lbs	<b>PBS8</b>

Note: Housing: Yellow vinyl rubber.

## Contact Interrupting Ratings, PBS Series

Two-Speed Single Break	Voltage	Current
AC	120V	6A
35% PF	240V	3A
DC	125V	.4A
IND	250V	.2A
Single-Speed Double Break	Voltage	Current
AC	120V	6A
35% PF	240V	3A
DC	125V	1.1A
IND	250V	.55A

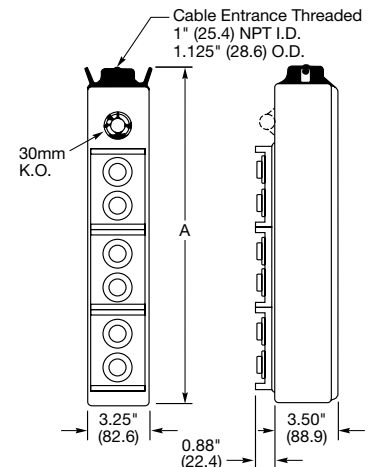

Dimensions in Inches (mm)

# Switched Disconnects and Enclosures



PG2



PG6



MS2



MS5



TB2



TB5



PBSLP



PBSBC



PBSPL1



07401023

## Replacement Inserts

When the insert switches are in need of replacement, simply unplug the old insert and plug in a new one.

Description	Catalog Number
Single speed insert momentary N.O. and N.C.	<b>PG2</b>
ON-OFF insert (no mechanical interlock). Momentary, start-stop, reset-stop.	<b>PG6</b>
2 or 3 speed insert, momentary. Used to a maximum of 3 speed points.	<b>MS2</b>
5 speed insert, momentary. Used to a maximum of 5 speed points. For five speed applications replace an existing terminal board with the TB5 terminal board and replace an existing insert with the five speed (MS5) insert.	<b>MS5</b>

## Conversion Inserts

In addition to single speed and two speed applications, pre-assembled units can be adapted to handle other applications.

Description	Catalog Number
Terminal board, required for each insert switch PG2, PG6 and MS2.	<b>TB2</b>
Terminal board, required for insert switch MS5.	<b>TB5</b>

## Accessories

Description	Catalog Number
Indicator labels for replacement package contains 1 each: hoist, trolley, bridge, forward-reverse, raise-lower, in-out, right left, east-west, north-south, reset-stop, start-stop, power, main hoist, auxiliary hoist, ON-OFF, up-down.	<b>PBSLP</b>
Rubber button cover for replacement purposes.	<b>PBSBC</b>
120V red pilot light for 4, 6, and 8 button units only.	<b>PBSPL1*</b>

Note: \*Each pendant station can accommodate one of the pilot light in the 1.20 in. (30.6) diameter mounting hole.

## Kellems® Deluxe Aluminum Cord Fitting

Outdoor or indoors where subject to moisture, splash or submersion. Kellems grips provide strain relief for multi-conductor cable.

Description	Cord Range	Catalog Number
Kellems grip.	.750"-.875" (19-22.2)	<b>07401023</b>
Kellems grip.	.875"-1.00" (22.2-25.4)	<b>07401025</b>