

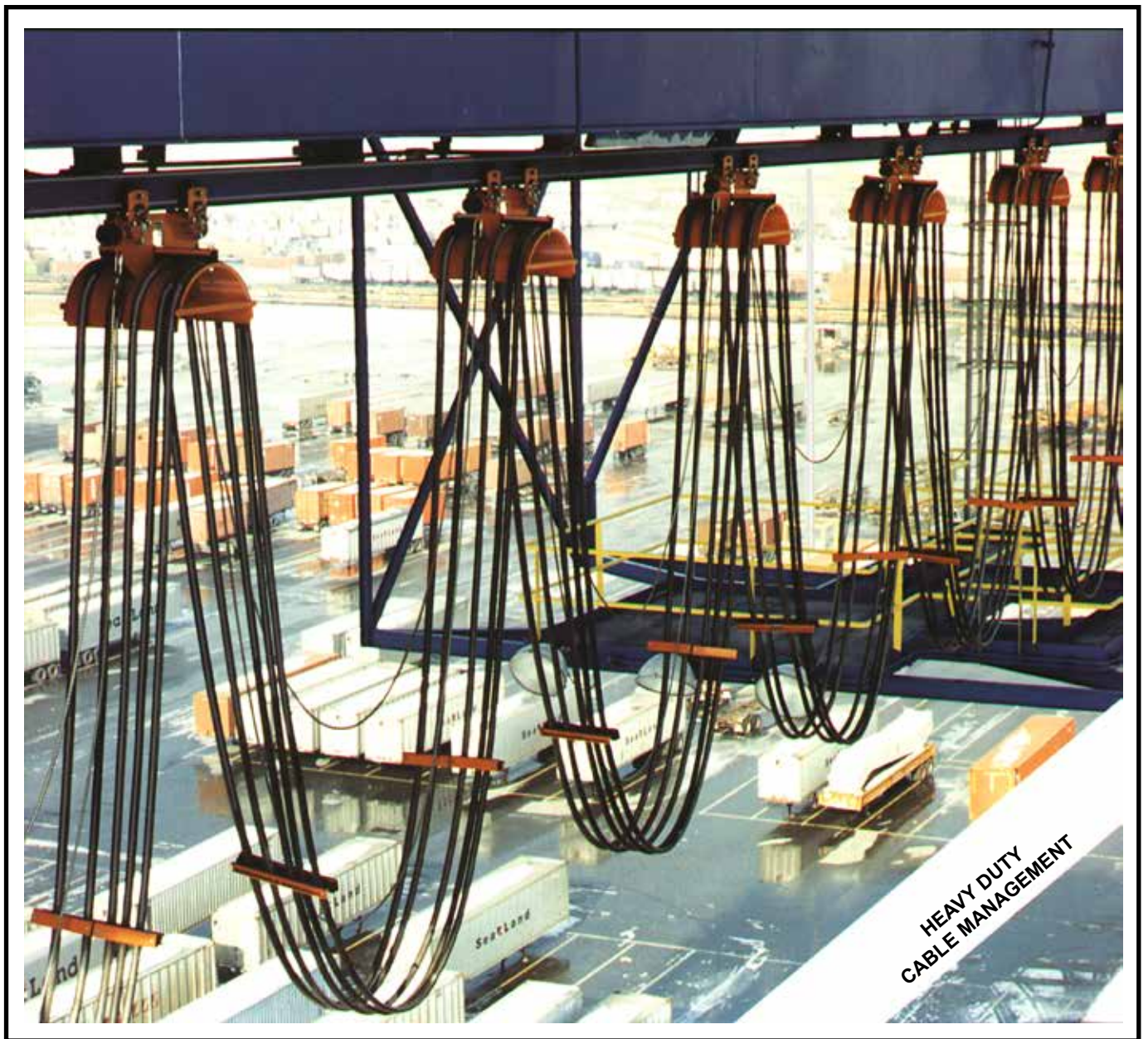

Beam·Master™ FESTOON SYSTEMS



HEAVY DUTY
CABLE MANAGEMENT

I-110 • I-115 • I-120 • I-130
I-152 & I-162

Heavy Duty I-Beam Supported Festoon Systems



I110-C Trolley with two clips

I130-D Trolley features two clamps for mixed cable/hose load

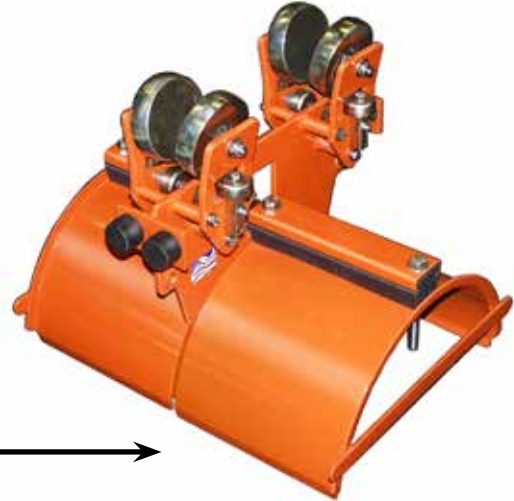

Typical Applications	Series	I-110	I-115	I-120	I-130	I-152	I-162
	LOAD MAX lbs. (kg)	150 (68)	450 (203)	450 (203)	700 (315)	900 (405)	1100 (495)
	SPEED MAX fpm (mpm)	350 (105)	500 (150)	500 (150)	650 (195)	650 (195)	800 (240)
<i>Container (Port) Cranes</i>				✓	✓	✓	✓
<i>Industrial Cranes & Hoists</i>		✓	✓	✓	✓	✓	✓
<i>Log Handling Cranes</i>		✓	✓	✓	✓	✓	✓
<i>Machine Tools</i>		✓	✓	✓	✓		
<i>Material Handling Equipment</i>		✓	✓	✓	✓		
<i>Production/Assembly/Process Lines</i>		✓	✓	✓	✓		
<i>Refuse Cranes</i>			✓	✓	✓	✓	✓
<i>Steel Mill Cranes</i>		✓	✓	✓	✓	✓	✓
<i>High Acceleration/Curves/Pendants, Etc.</i>	PLEASE CONSULT FACTORY FOR SPECIAL APPLICATIONS						

NOTE: Maximum speed possible only with lighter loads. Maximum loads possible only at slower speeds. Please consult factory.

WARRANTY

Gleason warrants for a period of twelve (12) months after date of shipment, all goods manufactured by it to be free from defects in material and workmanship. If, within such warranty period, any such goods are proved, to Gleason's satisfaction, to be defective, such goods shall be repaired or, at Gleason's option, replaced f.o.b. Gleason's factory, without charge. Gleason's obligation hereunder shall be confined to such repair or replacement and shall be further conditioned upon Gleason receiving written notice of any alleged defect within 10 days after its discovery and, at Gleason's option, the return of the alleged defective goods to Gleason, f.o.b. its factory.

The foregoing warranty shall not apply to goods not manufactured by Gleason, or to goods which shall have been repaired or altered by others than Gleason so as to, in Gleason's judgement, adversely affect the same, or which shall have been subject to other than normal use of service, negligence, accident, or improper maintenance care, or storage. With respect to goods furnished but not manufactured by Gleason, the warranty obligations of Gleason shall in all respects conform and be limited to the warranty extended to Gleason by the supplier.

The foregoing warranty is in lieu of all other express or implied warranties (except of title) and of all other obligations of Gleason.



ON THE COVER: Typical Gleason I-beam festoon system providing power and control to a crane.

Let Us Recommend a System Based on Your Data ...

Gleason's sophisticated computer program selects the appropriate festoon system based on data contained in this catalog as well as information supplied about your specific requirement. Local factory sales representatives have this program and are available for prompt response to your festoon needs. Please use the work sheet on the inside back cover to transmit all required data. Send or fax the form to your local Gleason representative or directly to the Gleason factory.

Contents

General Information		PAGE
Types in This Catalog		2
Application Photos		4-5
System Layout, Terminology		6-7
Cable and Hose Application Guidelines		7
Accessories		36-38
Options		39-40
I-Beam Data		41
Cable and Hose Data		42-43
Gleason Reel Product Line		44
Technical Data		PAGE
I110-C Series		10-12
I110-F Series		13-14
I110-M Series		15-17
I115-M Series		18-20
I120-S Series		21-22
I120-D Series		23-24
I130-M Series		25-26
I130-D Series		27-28
I152 & I162		29-35
Ordering		PAGE
Input for Application Program		8
Order Form		9



I115-M Trolley

BEAM·MASTER™ ...

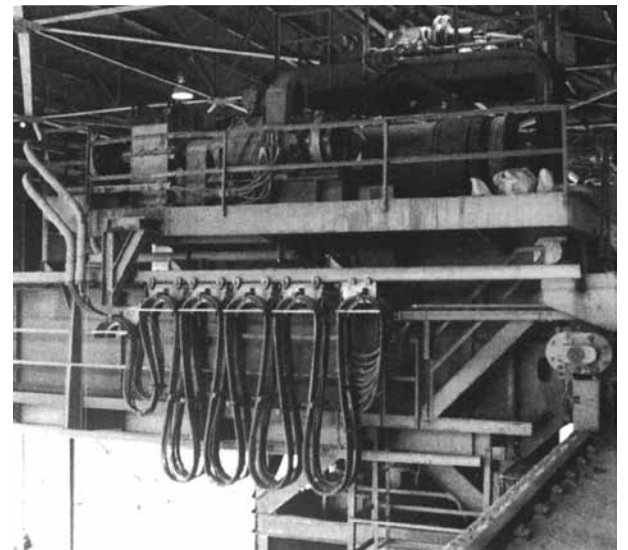
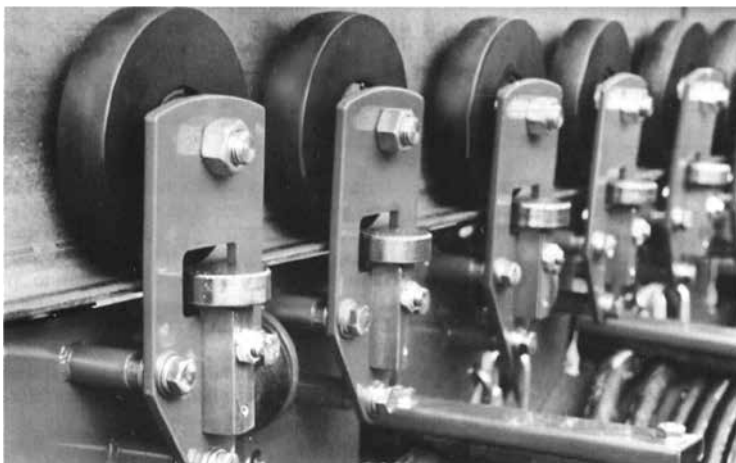
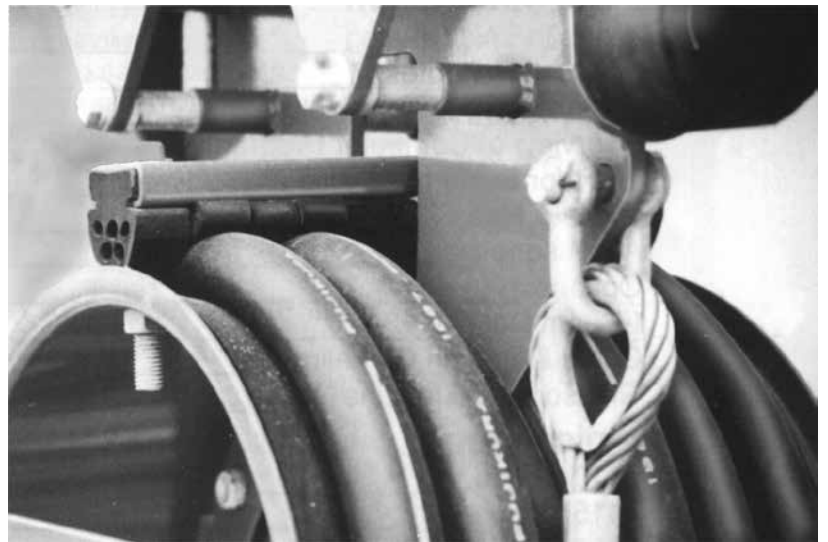
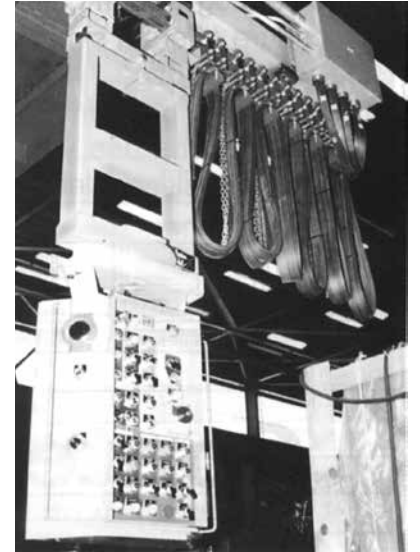
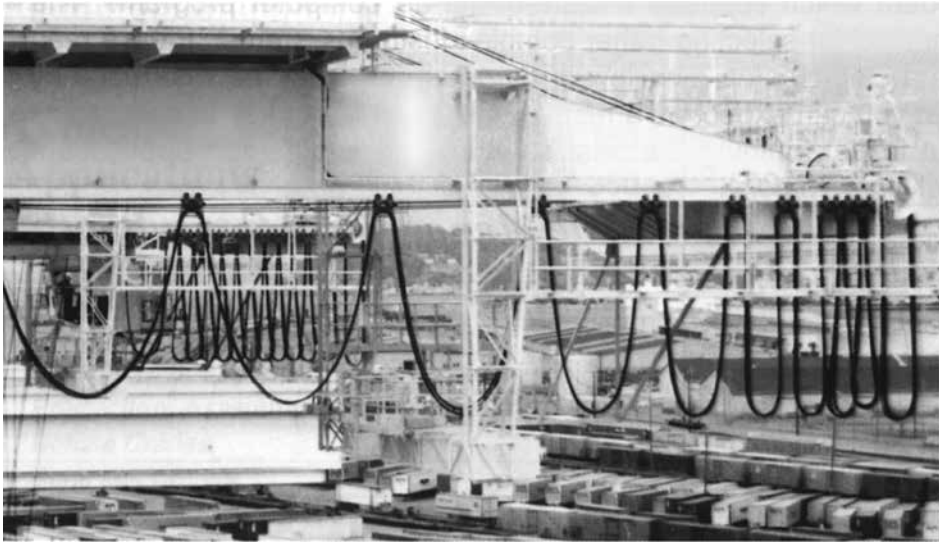

...On the Job

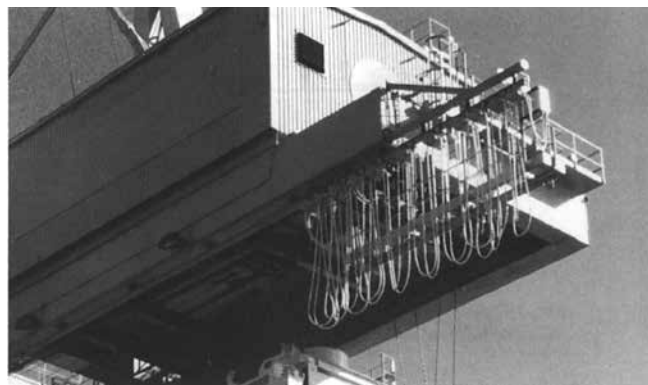
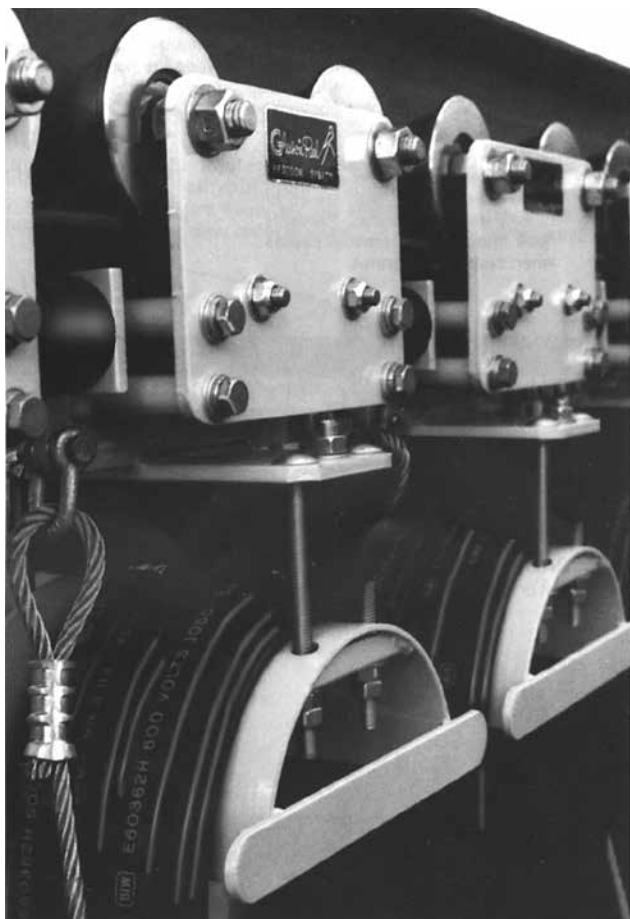
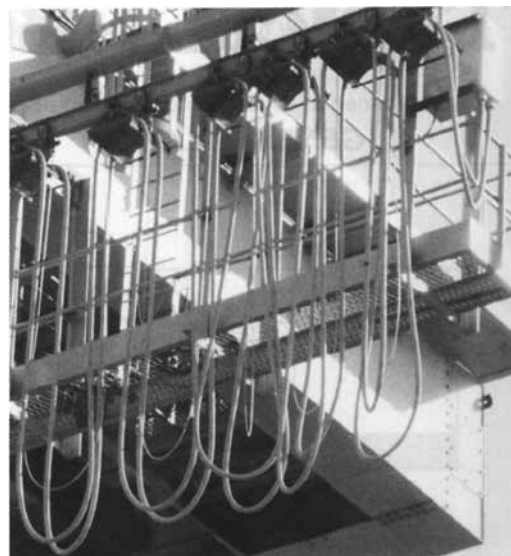
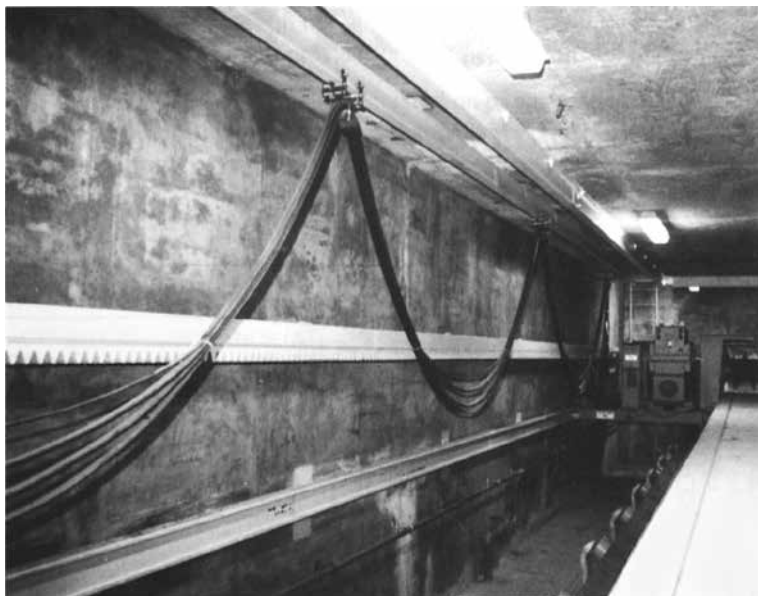

Typical I-Beam Festoon System

GENERAL LAYOUT • DEFINITIONS • DESCRIPTIONS • TERMS • SYMBOLS

SYSTEM IN STORED POSITION Flat cable shown. Round cable/hose similar.

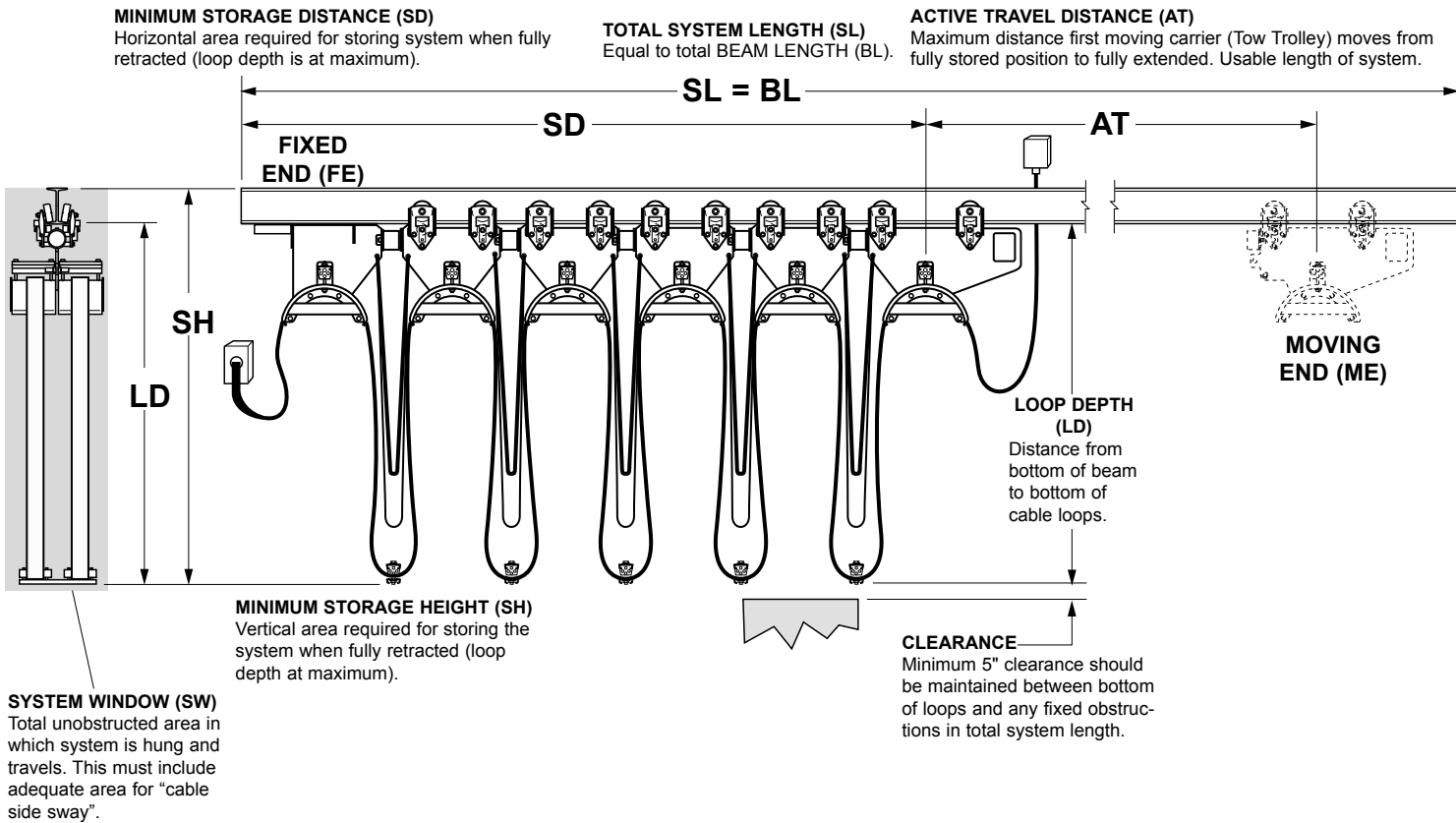

SYSTEM IN EXTENDED POSITION Flat cable shown. Round cable/hose similar.

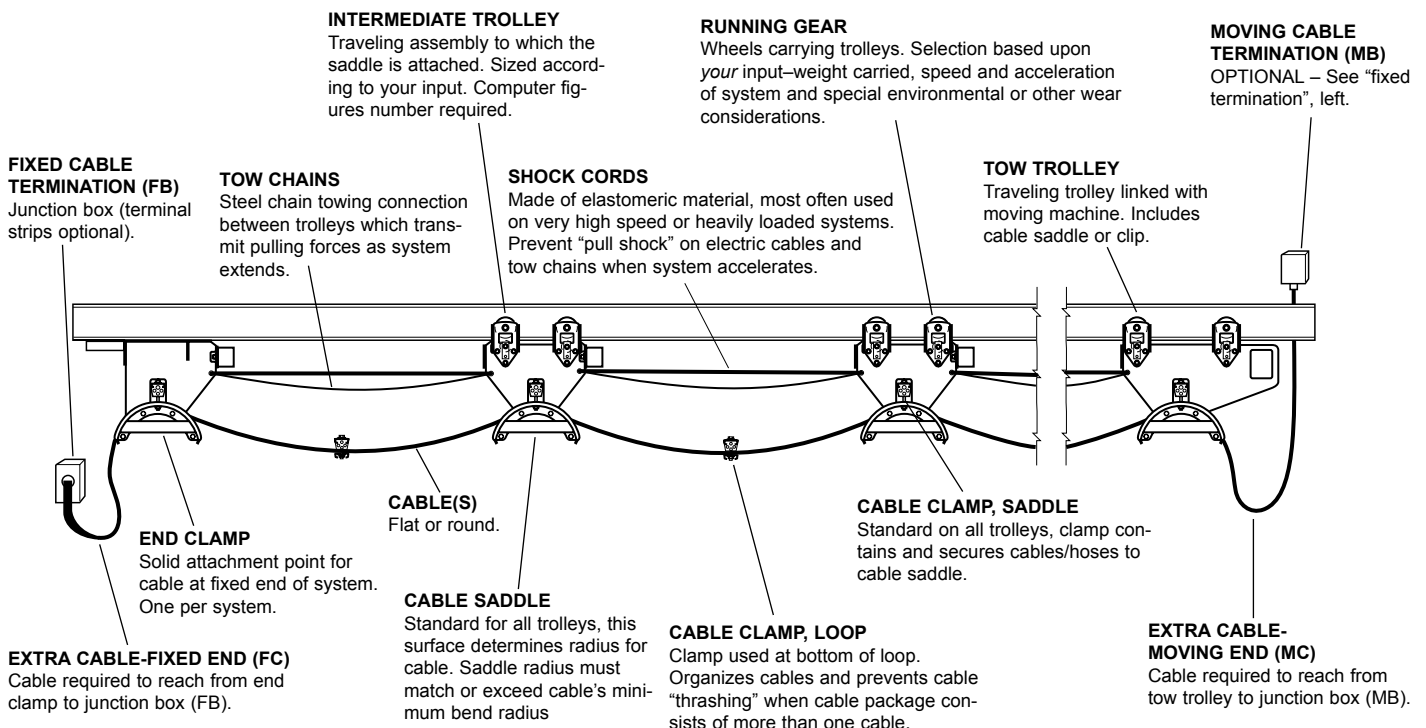

Beam·Master™ ...Extra Durable

Heavy duty components and high quality finishes make Gleason Beam·Master Festoon Systems rugged, smooth running and long lasting.

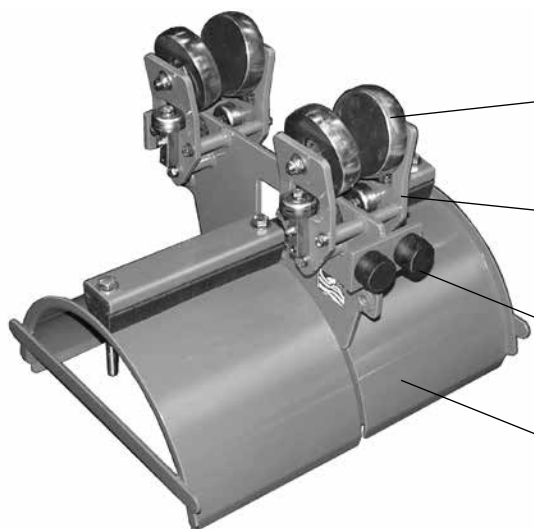

TYPICAL BEAM·MASTER TROLLEY (I-130 shown)

- Running Gear**
Either crowned (shown) or flanged.
Steel standard. Nylon available.
- Trolley Body**
Standard finish is baked on orange polyester powder coating.
- HEAVY DUTY BUMPERS**
Absorb impacts caused by trolleys "packing together" on stored end of system.
- Saddle**
For flat cable or mixed bundle. Standard finish is baked on orange polyester powder coating.

Cable & Saddle Guidelines

1. Bending Cable (All saddles and clips)

For good service and long life, it is best to follow the rule: "BIG BENDS ARE BEST". Cable producers vary in applying a multiplier. Gleason uses the chart below.

CABLE O.D..	MIN. RADIUS	MIN. SADDLE DIA.
Under 0.3 in.	3 x O.D	6 x O.D.
Under 0.5 in.	4 x O.D	8 x O.D.
Above 0.5 in.	5 x O.D	10 x O.D.



2. Cable O.D. Variations (Type M saddles)

Variations in cable size (O.D.) should be kept to a minimum. Clamping is most effective when all cables/hoses are the same O.D. or close as in figure 1. This ensures secure clamping. Wide variation in O.D. (Fig. 2) makes clamping difficult and cable/hose may not remain secure on the saddle.

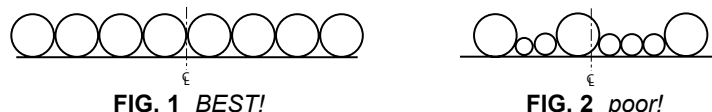

3. Balance in Loading Cable (Type M saddles)

This is important for smooth running, long bearing life and component alignment. Distribute the load evenly, with the heaviest cables nearest the centerline.

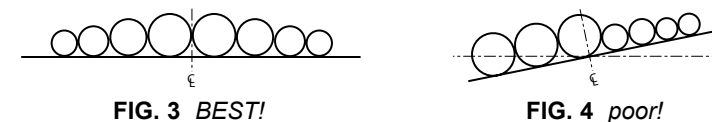

4. Flat Cable Stacking (Type F saddles)

a) Secure Clamping

EXTREMELY IMPORTANT: At least 50% of the cable surface must be under clamp pressure.

b) Height Consideration

Flat cable stacking is best when width is 3 or 4 times height (Fig. 5 & 6, above). High stacking can work as long as equal pressure is applied to all cables (Fig. 8).

c) Configuration

BIG CABLE ON TOP (Fig. 9) provides maximum bending radius for largest cables, improves heat dissipation for power cables, improves pulling force to largest cables when tow chains are not used.

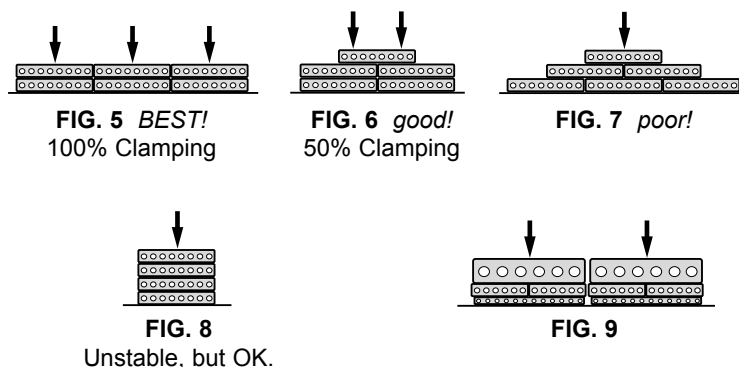

Input Required when Ordering

The following information is required so the Gleason computer software can recommend and quote the ideal festoon system for your application. Enter the data on the form at right and fax to your local Gleason Representative or directly to the Gleason factory at 920-387-4189.

CABLE/HOSE PACKAGE: Properly sizing a festoon system for the cable/hose it will carry is the only way to assure satisfactory operation and long life. Please fill in all known information about each size and type of cable or hose to be carried by your system. The information for the grey areas will be computer generated based on your input and published industry averages. Compare the cable/hose you will be using with the “**Cable & Hose Data**” in the back of this catalog. If the cable or hose you will be using is unusual in any way, insert the proper data as provided by the cable/hose manufacturer in the appropriate blanks within the grey area. This is especially important for *minimum bend radius* and *weight*. Refer to “**Cable & Saddle Guidelines**” (Page 7) for bending and stacking information.

EXAMPLE:

Qty. Each	Round/Flat	Jacket Type	CABLES		HOSES			O.D. or Thickness	Width (Flat)	Weight lb/ft	Min. Radius	
			AWG	Number Cond.	Fluid Density	Hose I.D.	Work Press.					
1)	1	FLAT	NEO	12	4				0.335*	0.945*	0.268*	1.34*
2)	1	FLAT	PVC	14	8				0.225*	1.225*	0.220*	0.675*
3)	2	ROUND	PVC	16	4				.520**		.205**	3.46**
4)	1	ROUND	NEO			OIL	.75	2000	1.32**		1.15**	6.60**

* This data was automatically entered by computer based on charts in back of catalog.

** Non-standard dimensions, weights or minimum bend radius must be entered by customer based on information obtained from cable/hose manufacturer.

SYSTEM PARAMETERS: How far must your system travel? At what speed? With how much acceleration? This is all data that must be known to properly apply a festoon system. See “**Typical I-Beam System**” (Page 6) for definitions and explanations of required information. Enter data on form at right.

EXAMPLE:

1) Active Travel (AT)	50 ft. 0 in.	6) Storage Distance (SD)	_____ ft. _____ in.
2) Loop Depth (LD)	4 ft. 0 in.	7) System Length (SL)	_____ ft. _____ in.
3) Maximum Speed	450 ft / min	System Length = Rail Length. Describe any known obstructions that could interfere with Beam Length. _____	
4) Acceleration	1.0 ft / s / s	_____	
5) Desired Model	_____	_____	

This will be calculated by computer if left blank.

OPTIONS: Included are such items as running gear wheel type and material (steel crowned is standard...nylon crowned and steel flanged wheels optional), lubrication type (life-time lubricated standard...re-greasable optional), hardware material (zinc plated steel standard...stainless steel optional). Enter options desired at right. If blank, standard is assumed.

ACCESSORIES: Make your system more functional with custom accessories). Some accessories such as cable clamps and tow chains will be computer recommended based on application. Where appropriate, all will be automatically sized to fit your system. Enter accessories desired on form at right.

Gleason also manufactures C-Rail Festoon systems in a complete range of sizes and capacities. While there is some capability overlap with beam systems, C-Rail festoons tend to be designed for lighter loads at lower speeds. For more information on Gleason C-Rail Festoons, see Catalog “FC”.



Inquiry Fax Form Industrial Festoon Systems

Fax to: _____ Fax Number: _____ Date _____

FOR FACTORY USE ONLY	
Representative	_____
Territory No.	_____
Date	_____

Total Quantity of Systems (this specification): _____

Application: _____

What is special? _____

**OUR COMPUTER
WILL GENERATE
THE DATA IN THE
SHADED PORTIONS
OF THIS FORM**

Customer	_____	
Address	_____	
City	_____	
State	_____	Zip _____
Phone	_____	Fax _____
Contact	_____	
Ref.	_____	

	CABLE PACKAGE			CABLES		HOSES			O.D. or Thickness*	Width (Flat)*	Weight lb/ft*	Min. Radius*	Price /Foot
	Qty. Each	Round /Flat	Jacket Type	AWG	Number Cond.	Fluid Density	Hose I.D.	Work Press.					
1)													
2)													
3)													
4)													
5)													
6)													
7)													

* This data will be automatically entered by computer based on charts in back of catalog. Non-standard dimensions, weights or minimum bend radii must be entered by customer based on information obtained from cable/hose manufacturer.

SYSTEM PARAMETERS

1) Active Travel (AT)	_____ ft. _____ in.
2) Loop Depth (LD)	_____ ft. _____ in.
3) Maximum Speed	_____ ft / min
4) Acceleration	_____ ft / s / s
5) Desired Model	_____

This will be calculated by computer if left blank.

6) Storage Distance (SD)	_____ ft. _____ in.
7) System Length (SL)	_____ ft. _____ in.

System Length = Rail Length. Describe any known obstructions that could interfere with Rail Length.

OPTIONS desired

1) Tow Device	<input type="checkbox"/> Tow Trolley	<input type="checkbox"/> Control Trolley
2) Hardware Mat'l	<input type="checkbox"/> Zinc Plated	<input type="checkbox"/> Stainless Steel
3) Wheel Mat'l	<input type="checkbox"/> Steel	<input type="checkbox"/> Nylon
4) Wheel Type	<input type="checkbox"/> Crowned	<input type="checkbox"/> Flanged
5) Bearing Lube	<input type="checkbox"/> Pre-lubricated	<input type="checkbox"/> Re-greasable

I-BEAM DATA:

IMPORTANT:	
1) Shape	<input type="checkbox"/> S <input type="checkbox"/> W or M
2) Designation	_____

ACCESSORIES desired

1) Cable Clamps	<input type="checkbox"/>
2) Ty-Wraps	<input type="checkbox"/>
3) Tow Chains	<input type="checkbox"/>
<i>Length will be calculated based on loop depth.</i>	
4) Cable Glands	<input type="checkbox"/>

5) Junction Boxes	<input type="checkbox"/>
NEMA	<input type="checkbox"/> Qty. _____
6) Pre-Assembly	<input type="checkbox"/>
7) Quote Cables	<input type="checkbox"/>
Extra Cable at:	
Moving End	_____ft.
Fixed End	_____ft.



GLEASON Beam·Master™

For **ROUND** Cable or Hose

SERIES I110-c

- SINGLE, DOUBLE, OR TRIPLE TIER CLIP DESIGN
- FLANGED 1.60" DIA. STEEL WHEELS STANDARD
- ANTI-LIFT ROLLERS STANDARD
- SEALED BALL BEARINGS STANDARD

- MAX CABLE/HOSE O.D. = 2.38"
- MAX TROLLEY LOAD = 150 lbs.
- TRAVEL SPEEDS TO 350 fpm
- ACCELERATION—Consult us if over 2.0 ft/sec².
- TRAVEL LENGTHS UNLIMITED

Standard Trolley Design

- Flanged 1.61" dia. steel wheels
- Anti-lift rollers
- Sealed bearings are pre-lubricated for life
- Tow trolley included as standard
- Zinc plated hardware
- Orange baked polyester powder finish
- Heavy duty bumpers
- Typical mounting on S3 or larger beams – contact us for special situations
- Cable/hose clips are adjustable †

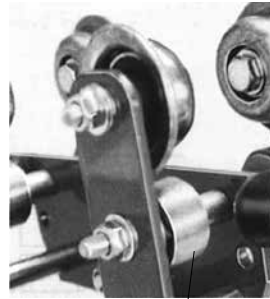

ANTI-LIFT ROLLERS INCLUDED

S

STEEL FLANGED WHEELS



ALL MAIN BEARINGS ARE SEALED AND USE PRECISION BALL BEARINGS

Model Number Explained

For STANDARD DESIGN, specific model numbers are on the following page.

TYPE	CLAMP STYLE	NO. OF TIERS (CLIPS)	CLIP O.D. CODE †	ITEM	Std. Hdw. HARDWARE MATERIAL	Std. Wheels** WHEEL MATERIAL	Your Beam
#I110	C	1	1	I	Z	S	<input type="text"/> <input type="text"/> <input type="text"/> x <input type="text"/> <input type="text"/> <input type="text"/> <input type="text"/>
Chosen by computer					Option you select		Minimum Beam Height = 3"
† CLIP O.D. CODES: 1 = 0.31-0.59 IN.; 2 = 0.60-0.94 IN.; 3 = 0.95-1.25 IN.					Hdwr Option		**Not applicable to end clamps
* Example above is for INTERMEDIATE TROLLEY (I)					Wheel Options		
Use same option changes (at right) for other components as required.					<input type="checkbox"/> STAINLESS <input type="checkbox"/> BRONZE <input type="checkbox"/> NYLON		

Option Design Features

CODE	OPTION
<input checked="" type="checkbox"/> N	FLANGED NYLON MAIN WHEELS WITH STEEL ANTI-LIFT ROLLERS
<input checked="" type="checkbox"/> B	BRONZE MAIN WHEELS WITH BRONZE ANTI-LIFT WHEELS
<input checked="" type="checkbox"/> S	STAINLESS STEEL HARDWARE
<input type="checkbox"/>	OTHER FINISHES AVAILABLE – PLEASE CONTACT US
<input type="checkbox"/>	PRE-ASSEMBLY ON SHIPPING FRAME AVAILABLE



B

BRONZE FLANGED WHEELS

BRONZE ANTI-LIFT ROLLERS



N

NYLON FLANGED WHEELS

STEEL ANTI-LIFT ROLLERS

Accessories

See detail pages at back of catalog

- CABLE CLAMPS
- TY-RAPS
- TOW CHAINS
- CABLE, ROUND OR FLAT; HOSE
- CABLE GLANDS FOR SINGLE CABLES OR GROUPS
- TERMINAL BOX(ES)
- TERMINAL BLOCKS

Series I110-C Components & Dimensions

For ROUND Cable or Hose

All dimensions in inches unless otherwise specified.

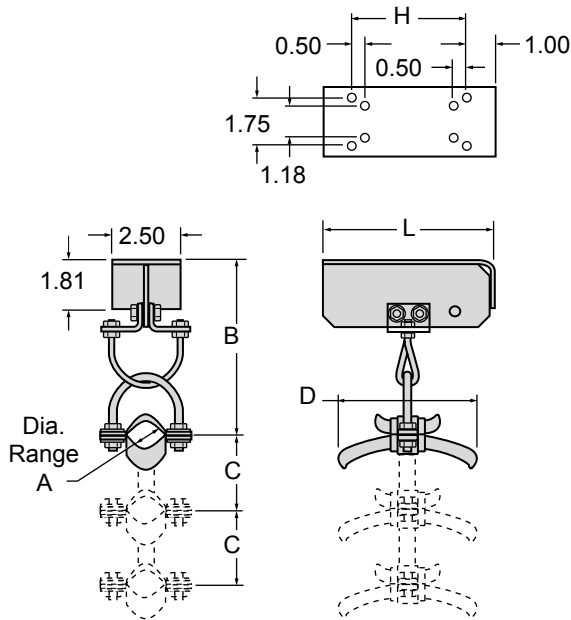

End Clip *One Required*

Model Number w/ Std Hardware	No. Tiers	Cable/Hose O.D. Range A	B	Cable Centers C	Clip Length D	Trolley Length L	Bolts H
I110-C11E-Z-S	1	0.31 - 0.59	3.82	-	2.75	6.16	4.94
I110-C12E-Z-S	1	0.60 - 0.94	3.94	-	3.86	6.16	4.94
I110-C13E-Z-S	1	0.95 - 1.25	7.19	-	5.59	6.16	4.94
I110-C14E-Z-S	1	1.26 - 1.69	7.94	-	6.89	10.56	8.56
I110-C15E-Z-S	1	1.70 - 2.38	8.44	-	9.65	10.56	8.56
I110-C21E-Z-S	2	0.31 - 0.59	3.82	1.31	2.75	6.16	4.94
I110-C22E-Z-S	2	0.60 - 0.94	3.94	1.88	3.86	6.16	4.94
I110-C23E-Z-S	2	0.95 - 1.25	7.19	3.06	5.59	6.16	4.94
I110-C24E-Z-S	2	1.26 - 1.69	7.94	3.62	6.89	10.56	8.56
I110-C25E-Z-S	2	1.70 - 2.38	8.44	4.25	9.65	10.56	8.56
I110-C31E-Z-S	3	0.31 - 0.59	3.82	1.31	2.75	6.16	4.94
I110-C32E-Z-S	3	0.60 - 0.94	3.94	1.88	3.86	6.16	4.94
I110-C33E-Z-S	3	0.95 - 1.25	7.19	3.06	5.59	6.16	4.94
I110-C34E-Z-S	3	1.26 - 1.69	7.94	3.62	6.89	10.56	8.56
I110-C35E-Z-S	3	1.70 - 2.38	8.44	4.25	9.65	10.56	8.56

Fits all beam sizes.

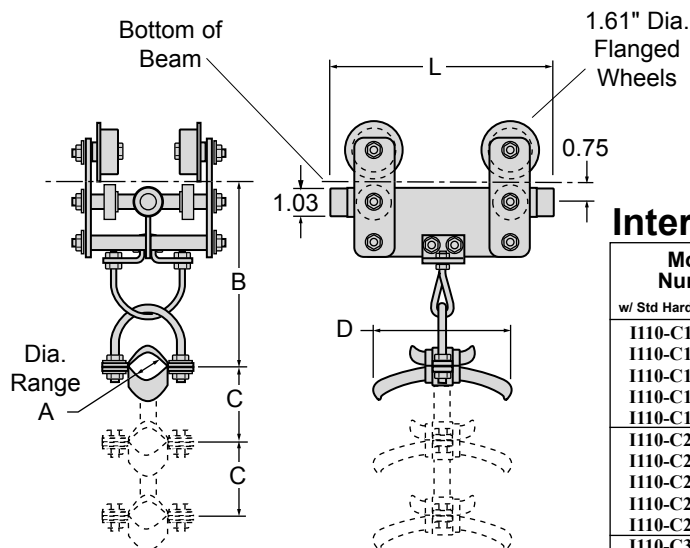

Intermediate Trolley *Quantity as Required*

Model Number w/ Std Hardware & Wheels	No. Tiers	Cable/Hose O.D. Range A	B	Cable Centers C	Clip Length D	Trolley Length L
I110-C11I-Z-S-□	1	0.31 - 0.59	4.25	-	2.75	6.31
I110-C12I-Z-S-□	1	0.60 - 0.94	4.38	-	3.86	6.31
I110-C13I-Z-S-□	1	0.95 - 1.25	7.19	-	5.59	6.31
I110-C14I-Z-S-□	1	1.26 - 1.69	7.94	-	6.89	6.31
I110-C15I-Z-S-□	1	1.70 - 2.38	8.44	-	9.65	6.31
I110-C21I-Z-S-□	2	0.31 - 0.59	4.25	1.31	2.75	6.31
I110-C22I-Z-S-□	2	0.60 - 0.94	4.38	1.88	3.85	6.31
I110-C23I-Z-S-□	2	0.95 - 1.25	7.19	3.06	5.59	6.31
I110-C24I-Z-S-□	2	1.26 - 1.69	7.94	3.62	6.89	6.31
I110-C25I-Z-S-□	2	1.70 - 2.38	8.44	4.25	9.65	6.31
I110-C31I-Z-S-□	3	0.31 - 0.59	4.25	1.31	2.75	6.31
I110-C32I-Z-S-□	3	0.60 - 0.94	4.38	1.88	3.86	6.31
I110-C33I-Z-S-□	3	0.95 - 1.25	7.19	3.06	5.59	6.31
I110-C34I-Z-S-□	3	1.26 - 1.69	7.94	3.62	6.89	6.31
I110-C35I-Z-S-□	3	1.70 - 2.38	8.44	4.25	9.65	6.31

Your beam size must be added to complete model number. See previous pages.

Series I110-C Components & Dimensions, con't.

For ROUND Cable or Hose

All dimensions in inches unless otherwise specified.

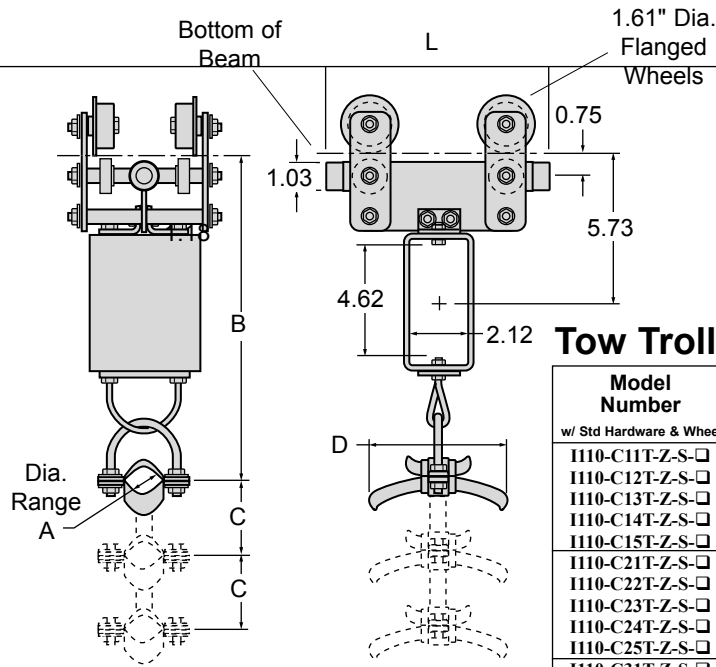

Tow Trolley *Standard...One Required*

Model Number	No. Tiers	Cable/Hose O.D. Range A	B	Cable Centers C	Clip Length D	Trolley Length L
<i>w/ Std Hardware & Wheels</i>						
I110-C11T-Z-S-□	1	0.31 - 0.59	9.32	-	2.75	7.88
I110-C12T-Z-S-□	1	0.60 - 0.94	9.44	-	3.86	7.88
I110-C13T-Z-S-□	1	0.95 - 1.25	12.69	-	5.59	7.88
I110-C14T-Z-S-□	1	1.26 - 1.69	13.44	-	6.89	7.88
I110-C15T-Z-S-□	1	1.70 - 2.38	13.94	-	9.65	7.88
I110-C21T-Z-S-□	2	0.31 - 0.59	9.32	1.31	2.75	7.88
I110-C22T-Z-S-□	2	0.60 - 0.94	9.44	1.88	3.86	7.88
I110-C23T-Z-S-□	2	0.95 - 1.25	12.69	3.06	5.59	7.88
I110-C24T-Z-S-□	2	1.26 - 1.69	13.44	3.62	6.89	7.88
I110-C25T-Z-S-□	2	1.70 - 2.38	13.94	4.25	9.65	7.88
I110-C31T-Z-S-□	3	0.31 - 0.59	9.32	1.31	2.75	7.88
I110-C32T-Z-S-□	3	0.60 - 0.94	9.44	1.88	3.86	7.88
I110-C33T-Z-S-□	3	0.95 - 1.25	12.69	3.06	5.59	7.88
I110-C34T-Z-S-□	3	1.26 - 1.69	13.44	3.62	6.89	7.88
I110-C35T-Z-S-□	3	1.70 - 2.38	13.94	4.25	9.65	7.88

Your beam size must be added to complete model number. See previous pages.

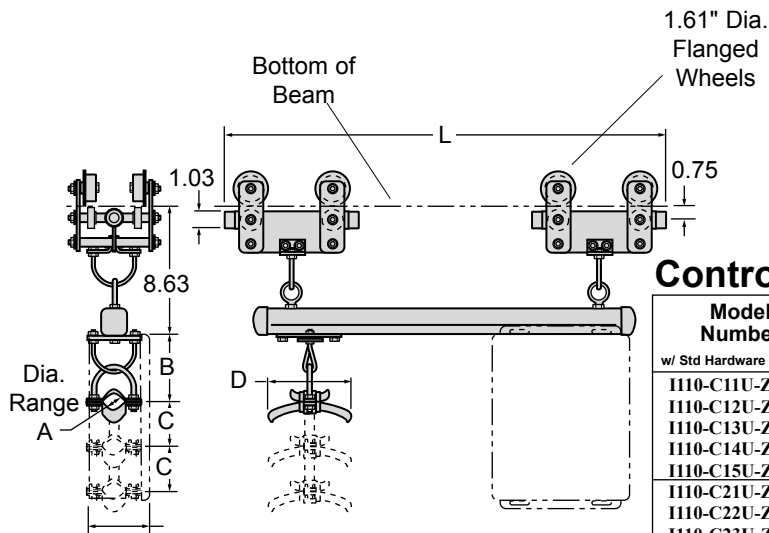

Control Unit Trolley *Optional Quantity as Required*

Model Number	No. Tiers	Cable/Hose O.D. Range A	B	Cable Centers C	Clip Length D	Trolley Length L	Overall Width W
<i>w/ Std Hardware & Wheels</i>							
I110-C11U-Z-S-□	1	0.31 - 0.59	1.12	-	2.75	33.50	6.00
I110-C12U-Z-S-□	1	0.60 - 0.94	1.25	-	3.86	33.50	6.00
I110-C13U-Z-S-□	1	0.95 - 1.25	3.99	-	5.59	33.50	6.00
I110-C14U-Z-S-□	1	1.26 - 1.69	4.25	-	6.89	33.50	6.00
I110-C15U-Z-S-□	1	1.70 - 2.38	4.88	-	9.65	33.50	6.00
I110-C21U-Z-S-□	2	0.31 - 0.59	1.12	1.31	2.75	33.50	6.00
I110-C22U-Z-S-□	2	0.60 - 0.94	1.25	1.88	3.86	33.50	6.00
I110-C23U-Z-S-□	2	0.95 - 1.25	3.99	3.06	5.59	33.50	6.00
I110-C24U-Z-S-□	2	1.26 - 1.69	4.25	3.62	6.89	33.50	6.00
I110-C25U-Z-S-□	2	1.70 - 2.38	4.88	4.25	9.65	33.50	6.00
I110-C31U-Z-S-□	3	0.31 - 0.59	1.12	1.31	2.75	33.50	6.00
I110-C32U-Z-S-□	3	0.60 - 0.94	1.25	1.88	3.86	33.50	6.00
I110-C33U-Z-S-□	3	0.95 - 1.25	3.99	3.06	5.59	33.50	6.00
I110-C34U-Z-S-□	3	1.26 - 1.69	4.25	3.62	6.89	33.50	6.00
I110-C35U-Z-S-□	3	1.70 - 2.38	4.88	4.25	9.65	33.50	6.00

Your beam size must be added to complete model number. See previous pages.

Note: Rail Mounted Junction Boxes are available. See "Accessories" section at back of catalog.

GLEASON Beam·Master™ SERIES I110-F

For FLAT Cable

- FLAT CLAMP DESIGN
- FLANGED 1.60" DIA. STEEL WHEELS STANDARD
- ANTI-LIFT ROLLERS STANDARD
- SEALED BALL BEARINGS STANDARD

- MAX SADDLE DIAMETER = 4.94"
- MAX TROLLEY LOAD = 150 lbs.
- TRAVEL SPEEDS TO 350 fpm
- ACCELERATION—Consult us if over 2.0 ft/sec².
- TRAVEL LENGTHS UNLIMITED

Standard Trolley Design

- Flanged 1.61" dia. steel wheels
- Anti-lift rollers
- Sealed bearings are pre-lubricated for life
- Tow trolley included as standard
- Zinc plated hardware
- Orange baked polyester powder finish
- Heavy duty bumpers
- Typical mounting on S3 or larger beams – contact us for special situations
- Cable clamp allows cable pkg height to vary up to 0.12"

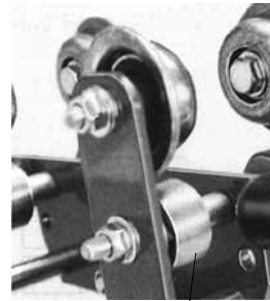

ANTI-LIFT ROLLERS INCLUDED

S

STEEL FLANGED WHEELS



ALL MAIN BEARINGS ARE SEALED AND USE PRECISION BALL BEARINGS

Model Number Explained

For STANDARD DESIGN, specific model numbers are on the following page.

TYPE	Standard Intermediate Trolley*			Std. Hdw. Hardware Material	Std. Wheels** Wheel Material	Your Beam
	CLAMP STYLE	SADDLE DIAMETER	WINDOW HEIGHT	WINDOW WIDTH		
#I110	F	03	- 15	02	- Z -	S - <input type="text"/> <input type="text"/> <input type="text"/> x <input type="text"/> <input type="text"/> <input type="text"/> . <input type="text"/>
Chosen by computer				Option you select	Hdwr Option	Wheel Options
					S STAINLESS	B BRONZE N NYLON
* Example above is for INTERMEDIATE TROLLEY (I) Use same option changes (at right) for other components as required.						Minimum Beam Height = 3"
						**Not applicable to end clamps

Option Design Features

CODE	OPTION
N	FLANGED NYLON MAIN WHEELS WITH STEEL ANTI-LIFT ROLLERS
B	BRONZE MAIN WHEELS WITH BRONZE ANTI-LIFT WHEELS
S	STAINLESS STEEL HARDWARE
<input type="checkbox"/>	OTHER FINISHES AVAILABLE – PLEASE CONTACT US
<input type="checkbox"/>	PRE-ASSEMBLY ON SHIPPING FRAME AVAILABLE



B

BRONZE FLANGED WHEELS

BRONZE ANTI-LIFT ROLLERS



N

NYLON FLANGED WHEELS

STEEL ANTI-LIFT ROLLERS

Accessories

See detail pages at back of catalog

- CABLE CLAMPS
- TY-RAPS
- FLAT CABLE
- CABLE GLANDS FOR SINGLE CABLES OR GROUPS
- TOW CHAINS
- TERMINAL BOX(ES)
- TERMINAL BLOCKS

Series I110-F Components & Dimensions

For FLAT Cable or Hose

All dimensions in inches unless otherwise specified.

End Clamp *One Required*

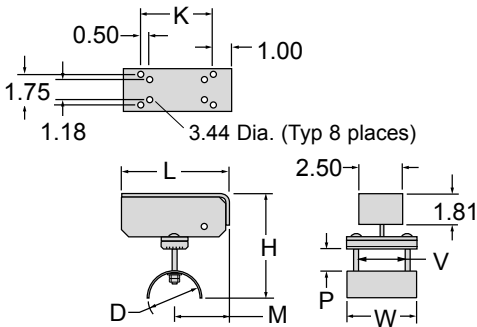

Model Number	Saddle Radius R	Saddle Dia. D	Window Height P	Window Width V	Overall Length L	Overall Width W	Below Beam H	Saddle Locator M	Bolts K
<i>w/ Std Hardware</i>									
I110-F03-1502E-Z	1.56	3.12	1.50	2.62	6.16	3.94	5.75	3.16	4.16
I110-F03-1505E-Z	1.56	3.12	1.50	5.00	6.16	6.31	5.75	3.16	4.16
I110-F03-2302E-Z	1.56	3.12	2.31	2.62	6.94	3.94	6.56	3.94	4.94
I110-F03-2305E-Z	1.56	3.12	2.31	5.00	6.94	6.31	6.56	3.94	4.94
I110-F04-0602E-Z	2.47	4.94	0.62	2.62	6.16	3.94	5.78	3.16	4.16
I110-F04-0605E-Z	2.47	4.94	0.62	5.00	6.16	6.31	5.78	3.16	4.16
I110-F04-1302E-Z	2.47	4.94	1.38	2.62	6.94	3.94	6.53	3.94	4.94
I110-F04-1305E-Z	2.47	4.94	1.38	5.00	6.94	6.31	6.53	3.94	4.94
I110-F04-2302E-Z	2.47	4.94	2.38	2.62	9.19	3.94	7.53	4.94	7.19
I110-F04-2305E-Z	2.47	4.94	2.38	5.00	9.19	6.31	7.53	4.94	7.19

Fits all beam sizes.

Intermediate Trolley *Quantity as Required*

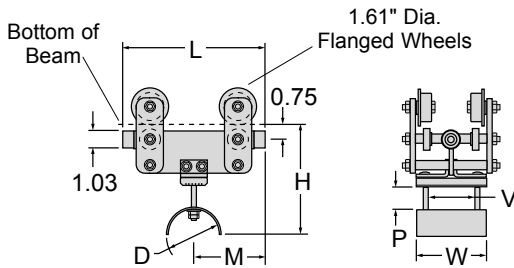

Model Number	Saddle Radius R	Saddle Dia. D	Window Height P	Window Width V	Overall Length L	Overall Width W	Below Beam H	Saddle Locator M
<i>w/ Std Hardware & Wheels</i>								
I110-F03-1502I-Z-S-□	1.56	3.12	1.50	2.62	6.31	3.94	6.50	3.16
I110-F03-1505I-Z-S-□	1.56	3.12	1.50	5.00	6.31	6.31	6.50	3.16
I110-F03-2302I-Z-S-□	1.56	3.12	2.31	2.62	7.88	3.94	7.31	3.94
I110-F03-2305I-Z-S-□	1.56	3.12	2.31	5.00	7.88	6.31	7.31	3.94
I110-F04-0602I-Z-S-□	2.47	4.94	0.62	2.62	6.31	3.94	6.53	3.16
I110-F04-0605I-Z-S-□	2.47	4.94	0.62	5.00	6.31	6.31	6.53	3.16
I110-F04-1302I-Z-S-□	2.47	4.94	1.38	2.62	7.88	3.94	7.31	3.94
I110-F04-1305I-Z-S-□	2.47	4.94	1.38	5.00	7.88	6.31	7.31	3.94
I110-F04-2302I-Z-S-□	2.47	4.94	2.38	2.62	9.88	3.94	8.31	4.94
I110-F04-2305I-Z-S-□	2.47	4.94	2.38	5.00	9.88	6.31	8.31	4.94

Your beam size must be added to complete model number. See previous pages.

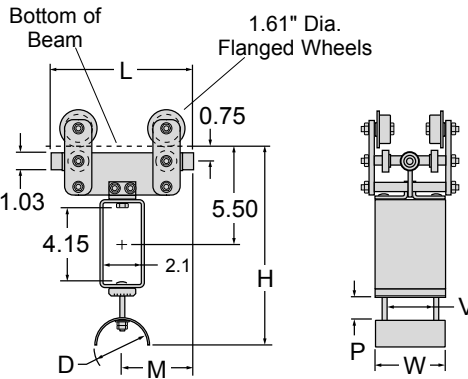

Tow Trolley *One Required*

Model Number	Saddle Radius R	Saddle Dia. D	Window Height P	Window Width V	Overall Length L	Overall Width W	Below Beam H	Saddle Locator M
<i>w/ Std Hardware & Wheels</i>								
I110-F03-1502T-Z-S-□	1.56	3.12	1.50	2.62	6.31	3.94	11.31	3.16
I110-F03-1505T-Z-S-□	1.56	3.12	1.50	5.00	6.31	6.31	11.31	3.16
I110-F03-2302T-Z-S-□	1.56	3.12	2.31	2.62	7.88	3.94	12.12	3.94
I110-F03-2305T-Z-S-□	1.56	3.12	2.31	5.00	7.88	6.31	12.12	3.94
I110-F04-0602T-Z-S-□	2.47	4.94	0.62	2.62	6.31	3.94	11.34	3.16
I110-F04-0605T-Z-S-□	2.47	4.94	0.62	5.00	6.31	6.31	11.34	3.16
I110-F04-1302T-Z-S-□	2.47	4.94	1.38	2.62	7.88	3.94	12.10	3.94
I110-F04-1305T-Z-S-□	2.47	4.94	1.38	5.00	7.88	6.31	12.10	3.94
I110-F04-2302T-Z-S-□	2.47	4.94	2.38	2.62	9.88	3.94	13.10	4.94
I110-F04-2305T-Z-S-□	2.47	4.94	2.38	5.00	9.88	6.31	13.10	4.94

Your beam size must be added to complete model number. See previous pages.

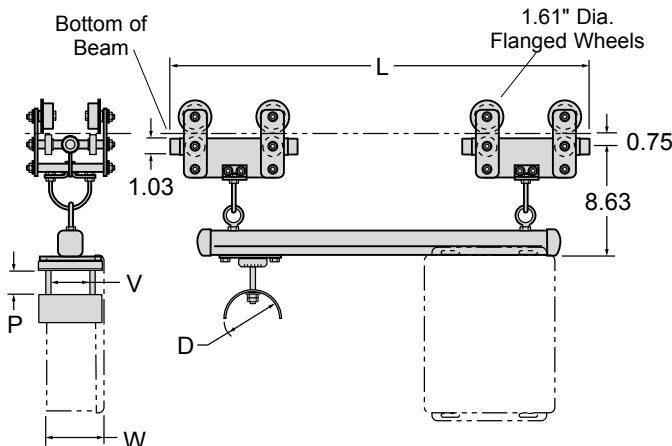

Control Unit Trolley *Optional Item* *Replaces Tow Trolley*

Model Number	Saddle Radius R	Saddle Dia. D	Window Height P	Window Width V	Overall Length L	Overall Width W
<i>w/ Std Hardware & Wheels</i>						
I110-F03-1502U-Z-S-□	1.56	3.12	1.50	2.62	33.50	6.00
I110-F03-1505U-Z-S-□	1.56	3.12	1.50	5.00	33.50	6.31
I110-F03-2302U-Z-S-□	1.56	3.12	2.31	2.62	33.50	6.00
I110-F03-2305U-Z-S-□	1.56	3.12	2.31	5.00	33.50	6.31
I110-F04-0602U-Z-S-□	2.47	4.94	0.62	2.62	33.50	6.00
I110-F04-0605U-Z-S-□	2.47	4.94	0.62	5.00	33.50	6.31
I110-F04-1302U-Z-S-□	2.47	4.94	1.38	2.62	33.50	6.00
I110-F04-1305U-Z-S-□	2.47	4.94	1.38	5.00	33.50	6.31
I110-F04-2302U-Z-S-□	2.47	4.94	2.38	2.62	33.50	6.00
I110-F04-2305U-Z-S-□	2.47	4.94	2.38	5.00	33.50	6.31

Your beam size must be added to complete model number. See previous pages.

GLEASON **Beam·Master**™ SERIES **I110-M**

For MIXED Cable or Hose

- FLAT, ROUND OR MIXED CABLE/HOSE
- FLANGED 1.60" DIA. STEEL WHEELS STANDARD
- ANTI-LIFT ROLLERS STANDARD
- SEALED BALL BEARINGS STANDARD

- MAX SADDLE DIAMETER = 12.59"
- MAX TROLLEY LOAD = 150 lbs.
- TRAVEL SPEEDS TO 350 fpm
- ACCELERATION—Consult us if over 2.0 ft/sec².
- TRAVEL LENGTHS UNLIMITED

Standard Trolley Design

- Flanged 1.60" dia. steel wheels
- Anti-lift rollers
- Sealed bearings are pre-lubricated for life
- Tow trolley included as standard
- Zinc plated hardware
- Orange baked polyester powder finish
- Heavy duty bumpers
- Typical mounting on S3 or larger beams – contact us for special situations
- Cable clamp allows cable pkg height to vary up to 0.25"

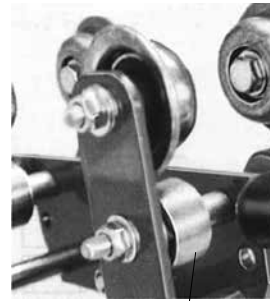

ANTI-LIFT ROLLERS INCLUDED

S

STEEL FLANGED WHEELS



ALL MAIN BEARINGS ARE SEALED AND USE PRECISION BALL BEARINGS

Model Number Explained

For STANDARD DESIGN, specific model numbers are on the following page.

TYPE	CLAMP STYLE	SADDLE DIAMETER	WINDOW HEIGHT	WINDOW WIDTH	ITEM	Std. Hdw. HARDWARE MATERIAL	Std. Wheels** WHEEL MATERIAL	Your Beam
#I110	- M	06	- 06	02	I	- Z ZINC PLATED	- S - STEEL	 Minimum Beam Height = 3"
Chosen by computer			Options You select			Options	Wheel Options	**Not applicable to end clamps
* Example above is for INTERMEDIATE TROLLEY (I) Use same option changes (at right) for other components as required.						S STAINLESS	B BRONZE N NYLON	

Option Design Features

CODE	OPTION
N	FLANGED NYLON MAIN WHEELS WITH STEEL ANTI-LIFT ROLLERS
B	BRONZE MAIN WHEELS WITH BRONZE ANTI-LIFT WHEELS
S	STAINLESS STEEL HARDWARE
<input type="checkbox"/>	OTHER FINISHES AVAILABLE – PLEASE CONTACT US
<input type="checkbox"/>	PRE-ASSEMBLY ON SHIPPING FRAME AVAILABLE



B
BRONZE FLANGED WHEELS
BRONZE ANTI-LIFT ROLLERS



N
NYLON FLANGED WHEELS
STEEL ANTI-LIFT ROLLERS

Accessories

See detail pages at back of catalog

- CABLE CLAMPS
- TY-RAPS
- TOW CHAINS
- CABLE, ROUND OR FLAT; HOSE
- CABLE GLANDS FOR SINGLE CABLES OR GROUPS
- TERMINAL BOX(ES)
- TERMINAL BLOCKS

Series I110-M Components & Dimensions

For MIXED Cable or Hose

All dimensions in inches unless otherwise specified.

End Clamp *One Required*

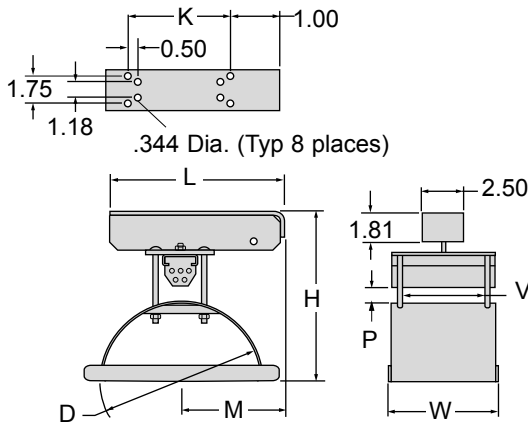

Model Number w/ Std Hardware	Saddle Radius R	Saddle Dia. D	Window Height P	Window Width V	Overall Length L	Overall Width W	Below Beam H	Saddle Locator M	Bolts K
I110-M06-0602E-Z	3.16	6.31	0.69	2.62	6.94	3.94	6.53	3.94	4.94
I110-M06-0605E-Z	3.16	6.31	0.69	5.00	6.94	6.31	6.53	3.94	4.94
I110-M06-1602E-Z	3.16	6.31	1.69	2.62	9.19	3.94	7.53	4.94	7.19
I110-M06-1605E-Z	3.16	6.31	1.69	5.00	9.19	6.31	7.53	4.94	7.19
I110-M06-2202E-Z	3.16	6.31	2.25	2.62	9.75	3.94	8.09	5.50	7.75
I110-M06-2205E-Z	3.16	6.31	2.25	5.00	9.75	6.31	8.09	5.50	7.75
I110-M07-0802E-Z	3.94	7.88	0.81	2.62	9.19	4.31	7.44	4.94	7.19
I110-M07-0805E-Z	3.94	7.88	0.81	5.00	9.19	6.69	7.44	4.94	7.19
I110-M07-0806E-Z	3.94	7.88	0.81	6.56	9.19	8.25	7.44	4.94	7.19
I110-M07-0808E-Z	3.94	7.88	0.81	8.56	9.19	10.25	7.44	4.94	7.19
I110-M07-1302E-Z	3.94	7.88	1.38	2.62	9.75	4.31	8.00	5.50	7.75
I110-M07-1305E-Z	3.94	7.88	1.38	5.00	9.75	6.69	8.00	5.50	7.75
I110-M07-1306E-Z	3.94	7.88	1.38	6.56	9.75	8.25	8.00	5.50	7.75
I110-M07-1308E-Z	3.94	7.88	1.38	8.56	9.75	10.25	8.00	5.50	7.75
I110-M07-2102E-Z	3.94	7.88	2.19	2.62	9.75	4.31	8.81	6.30	8.56
I110-M07-2105E-Z	3.94	7.88	2.19	5.00	10.56	6.69	8.81	6.30	8.56
I110-M07-2106E-Z	3.94	7.88	2.19	6.56	10.56	8.25	8.81	6.30	8.56
I110-M07-2108E-Z	3.94	7.88	2.19	8.56	10.56	10.25	8.81	6.30	8.56
I110-M09-1305E-Z	4.94	9.88	1.38	5.00	10.56	6.69	9.00	6.30	8.56
I110-M09-1306E-Z	4.94	9.88	1.38	6.56	10.56	8.25	9.00	6.30	8.56
I110-M09-1308E-Z	4.94	9.88	1.38	8.56	10.56	10.25	9.00	6.30	8.56
I110-M09-2705E-Z	4.94	9.88	2.75	5.00	12.12	6.69	10.38	7.88	10.12
I110-M09-2706E-Z	4.94	9.88	2.75	6.56	12.12	8.25	10.38	7.88	10.12
I110-M09-2708E-Z	4.94	9.88	2.75	8.56	12.12	10.25	10.38	7.88	10.12
I110-M12-1305E-Z	6.30	12.59	1.38	5.00	12.12	6.69	10.37	7.88	10.12
I110-M12-1306E-Z	6.30	12.59	1.38	6.56	12.12	8.25	10.37	7.88	10.12
I110-M12-1308E-Z	6.30	12.59	1.38	8.56	12.12	10.25	10.37	7.88	10.12

Fits all beam sizes.

Intermediate Trolley *Quantity as Required*

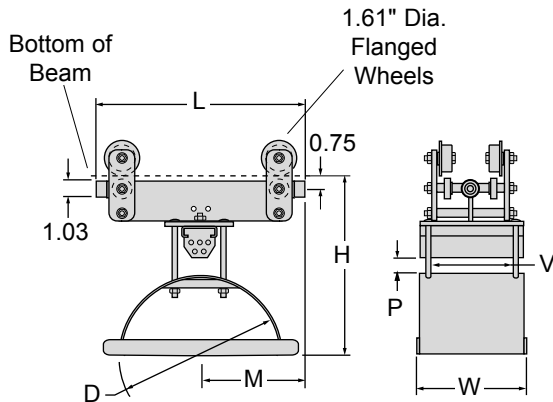

Model Number w/ Std Hardware & Wheels	Saddle Radius R	Saddle Dia. D	Window Height P	Window Width V	Overall Length L	Overall Width W	Below Beam H	Saddle Locator M
I110-M06-0602I-Z-S-□	3.16	6.31	0.69	2.62	7.88	3.94	8.73	3.94
I110-M06-0605I-Z-S-□	3.16	6.31	0.69	5.00	7.88	6.31	8.73	3.94
I110-M06-1602I-Z-S-□	3.16	6.31	1.69	2.62	9.88	3.94	9.73	4.94
I110-M06-1605I-Z-S-□	3.16	6.31	1.69	5.00	9.88	6.31	9.73	4.94
I110-M06-2202I-Z-S-□	3.16	6.31	2.25	2.62	11.00	3.94	10.28	5.50
I110-M06-2205I-Z-S-□	3.16	6.31	2.25	5.00	11.00	6.31	10.28	5.50
I110-M07-0802I-Z-S-□	3.94	7.88	0.81	2.62	9.88	4.31	9.63	4.94
I110-M07-0805I-Z-S-□	3.94	7.88	0.81	5.00	9.88	6.69	9.63	4.94
I110-M07-0806I-Z-S-□	3.94	7.88	0.81	6.56	9.88	8.25	9.63	4.94
I110-M07-0808I-Z-S-□	3.94	7.88	0.81	8.56	9.88	10.25	9.63	4.94
I110-M07-1302I-Z-S-□	3.94	7.88	1.38	2.62	11.00	4.31	10.19	5.50
I110-M07-1305I-Z-S-□	3.94	7.88	1.38	5.00	11.00	6.69	10.19	5.50
I110-M07-1306I-Z-S-□	3.94	7.88	1.38	6.56	11.00	8.25	10.19	5.50
I110-M07-1308I-Z-S-□	3.94	7.88	1.38	8.56	11.00	10.25	10.19	5.50
I110-M07-2102I-Z-S-□	3.94	7.88	2.19	2.62	12.59	4.31	11.00	6.30
I110-M07-2105I-Z-S-□	3.94	7.88	2.19	5.00	12.59	6.69	11.00	6.30
I110-M07-2106I-Z-S-□	3.94	7.88	2.19	6.56	12.59	8.25	11.00	6.30
I110-M07-2108I-Z-S-□	3.94	7.88	2.19	8.56	12.59	10.25	11.00	6.30
I110-M09-1305I-Z-S-□	4.94	9.88	1.38	5.00	12.59	6.69	11.19	6.30
I110-M09-1306I-Z-S-□	4.94	9.88	1.38	6.56	12.59	8.25	11.19	6.30
I110-M09-1308I-Z-S-□	4.94	9.88	1.38	8.56	12.59	10.25	11.19	6.30
I110-M09-2705I-Z-S-□	4.94	9.88	2.75	5.00	15.75	6.69	12.56	7.88
I110-M09-2706I-Z-S-□	4.94	9.88	2.75	6.56	15.75	8.25	12.56	7.88
I110-M09-2708I-Z-S-□	4.94	9.88	2.75	8.56	15.75	10.25	12.56	7.88
I110-M12-1305I-Z-S-□	6.30	12.59	1.38	5.00	15.75	6.69	12.56	7.88
I110-M12-1306I-Z-S-□	6.30	12.59	1.38	6.56	15.75	8.25	12.56	7.88
I110-M12-1308I-Z-S-□	6.30	12.59	1.38	8.56	15.75	10.25	12.56	7.88

Your beam size must be added to complete model number.
See previous pages.

Series I110-M Components & Dimensions, con't.

For MIXED Cable or Hose

All dimensions in inches unless otherwise specified.

Tow Trolley *Standard...One Required*

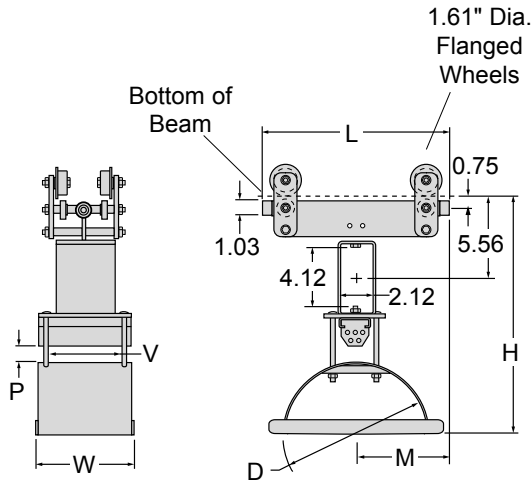

Model Number	Saddle Radius R	Saddle Dia. D	Window Height P	Window Width V	Overall Length L	Overall Width W	Below Beam H	Saddle Locator M
I110-M06-0602T-Z-S-□	3.16	6.31	0.69	2.62	7.88	3.94	14.00	3.94
I110-M06-0605T-Z-S-□	3.16	6.31	0.69	5.00	7.88	6.31	14.00	3.94
I110-M06-1602T-Z-S-□	3.16	6.31	1.69	2.62	9.88	3.94	15.00	4.94
I110-M06-1605T-Z-S-□	3.16	6.31	1.69	5.00	9.88	6.31	15.00	4.94
I110-M06-2202T-Z-S-□	3.16	6.31	2.25	2.62	11.00	3.94	15.53	5.50
I110-M06-2205T-Z-S-□	3.16	6.31	2.25	5.00	11.00	6.31	15.53	5.50
I110-M07-0802T-Z-S-□	3.94	7.88	0.81	2.62	9.88	4.31	14.88	4.94
I110-M07-0805T-Z-S-□	3.94	7.88	0.81	5.00	9.88	6.69	14.88	4.94
I110-M07-0806T-Z-S-□	3.94	7.88	0.81	6.56	9.88	8.25	14.88	4.94
I110-M07-0808T-Z-S-□	3.94	7.88	0.81	8.56	9.88	10.25	14.88	4.94
I110-M07-1302T-Z-S-□	3.94	7.88	1.38	2.62	11.00	4.31	15.44	5.50
I110-M07-1305T-Z-S-□	3.94	7.88	1.38	5.00	11.00	6.69	15.44	5.50
I110-M07-1306T-Z-S-□	3.94	7.88	1.38	6.56	11.00	8.25	15.44	5.50
I110-M07-1308T-Z-S-□	3.94	7.88	1.38	8.56	11.00	10.25	15.44	5.50
I110-M07-2102T-Z-S-□	3.94	7.88	2.19	2.62	12.59	4.31	16.25	6.30
I110-M07-2105T-Z-S-□	3.94	7.88	2.19	5.00	12.59	6.69	16.25	6.30
I110-M07-2106T-Z-S-□	3.94	7.88	2.19	6.56	12.59	8.25	16.25	6.30
I110-M07-2108T-Z-S-□	3.94	7.88	2.19	8.56	12.59	10.25	16.25	6.30
I110-M09-1305T-Z-S-□	4.94	9.88	1.38	5.00	12.59	6.69	16.44	6.30
I110-M09-1306T-Z-S-□	4.94	9.88	1.38	6.56	12.59	8.25	16.44	6.30
I110-M09-1308T-Z-S-□	4.94	9.88	1.38	8.56	12.59	10.25	16.44	6.30
I110-M09-2705T-Z-S-□	4.94	9.88	2.75	5.00	15.75	6.69	17.81	7.88
I110-M09-2706T-Z-S-□	4.94	9.88	2.75	6.56	15.75	8.25	17.81	7.88
I110-M09-2708T-Z-S-□	4.94	9.88	2.75	8.56	15.75	10.25	17.81	7.88
I110-M12-1305T-Z-S-□	6.30	12.59	1.38	5.00	15.75	6.69	17.81	7.88
I110-M12-1306T-Z-S-□	6.30	12.59	1.38	6.56	15.75	8.25	17.81	7.88
I110-M12-1308T-Z-S-□	6.30	12.59	1.38	8.56	15.75	10.25	17.81	7.88

Your beam size must be added to complete model number. See previous pages.

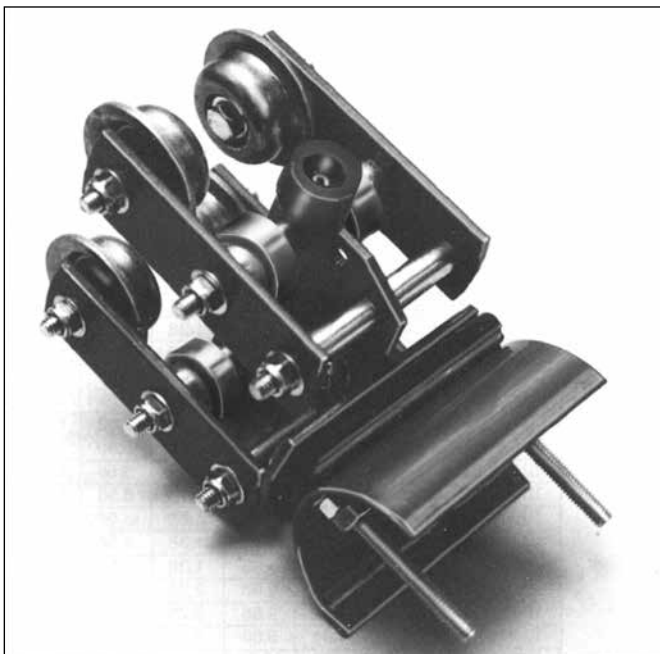

Typical I110-F Intermediate Trolley

GLEASON **Beam·Master**™ SERIES **I115-M**

For MIXED Cable or Hose

- FLAT, ROUND OR MIXED CABLE/HOSE
- CROWNED 2.48" DIA. STEEL WHEELS STANDARD
- ANTI-LIFT ROLLERS STANDARD
- SEALED BALL BEARINGS STANDARD

- MAX SADDLE DIAMETER = 12.59"
- MAX TROLLEY LOAD = 450 lbs.
- TRAVEL SPEEDS TO 500 fpm
- ACCELERATION—Consult us if over 2.0 ft/sec².
- TRAVEL LENGTHS UNLIMITED

Standard Trolley Design

- **Crowned 2.48" steel wheels with side guide rollers.**
- **Anti-lift rollers**
- **Sealed bearings are pre-lubricated for life**
- **Tow trolley included as standard**
- **Zinc plated hardware**
- **Orange baked polyester powder finish**
- **Heavy duty bumpers**
- **Typical mounting on S5 or larger beams (S3 or larger with optional flanged wheels)— contact us for special situations**
- **Cable clamp allows cable pkg height to vary up to 0.63"**

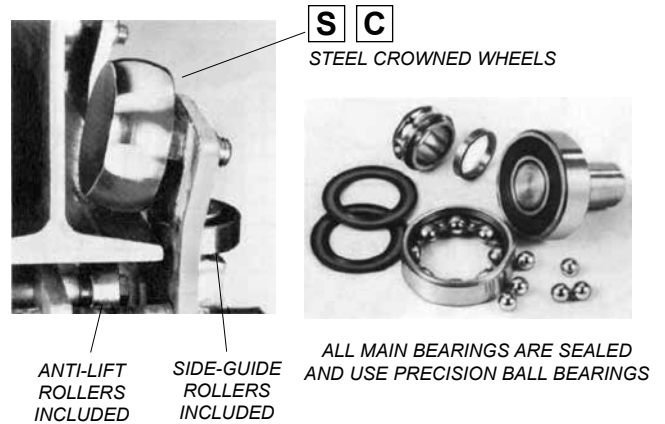

Model Number Explained

For STANDARD DESIGN, specific model numbers are on the following page.

Standard Intermediate Trolley*							Standard	Std. Wheels***	Your Beam		
TYPE	CLAMP STYLE	SADDLE DIAMETER	HEIGHT	WINDOW WIDTH	WINDOW ITEM	FINISH	WHEEL MAT'L	WHEEL STYLE	WHEEL LUBE		
#I115	M	04	- 21	02	I	Z -	S	C	P-	<input type="checkbox"/> <input type="checkbox"/> <input type="checkbox"/> x <input type="checkbox"/> <input type="checkbox"/> <input type="checkbox"/>	
Chosen by computer						ZINC HARDWARE PAINTED TROLLEY	STEEL	CROWNED	PRE-LUB		
Options you select						Options	Wheel Options			Minimum Beam Height = 5.0"	
						S STAINLESS	G GALVANIZED	N NYLON	F FLANGED	G REGREASE	

* Example above is for INTERMEDIATE TROLLEY (I)
Use same option changes (at right) for other components as required

Optional Design Features

CODE	OPTION
F	FLANGED (STEEL ONLY) WHEELS WITH ANTI-LIFT ROLLERS
N	CROWNED NYLON WHEELS WITH STEEL SIDE GUIDE ROLLERS
G	RE-GREASABLE BEARINGS ON MAIN WHEELS
S	STAINLESS STEEL HARDWARE
<input type="checkbox"/>	OTHER FINISHES AVAILABLE – PLEASE CONTACT US
<input type="checkbox"/>	PRE-ASSEMBLY ON SHIPPING FRAME AVAILABLE

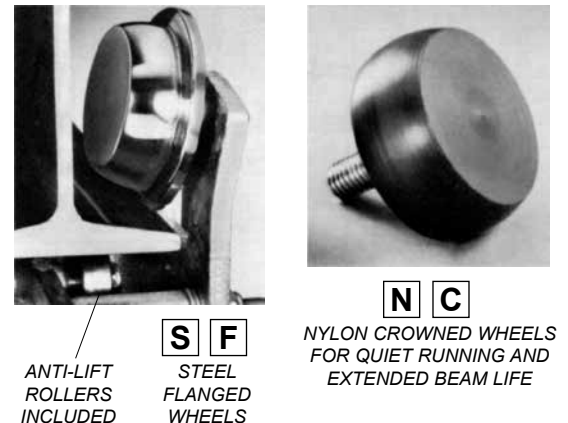

Accessories

- See detail pages at back of catalog
- CABLE CLAMPS • SHOCK CORDS • CABLE, ROUND OR FLAT; HOSE • TERMINAL BOX(ES)
 - TY-RAPS • CABLE GLANDS FOR SINGLE CABLES OR GROUPS
 - TERMINAL BLOCKS • TOW CHAINS

Series I115-M Components & Dimensions

For MIXED Cable or Hose

All dimensions in inches unless otherwise specified.

End Clamp *One Required*

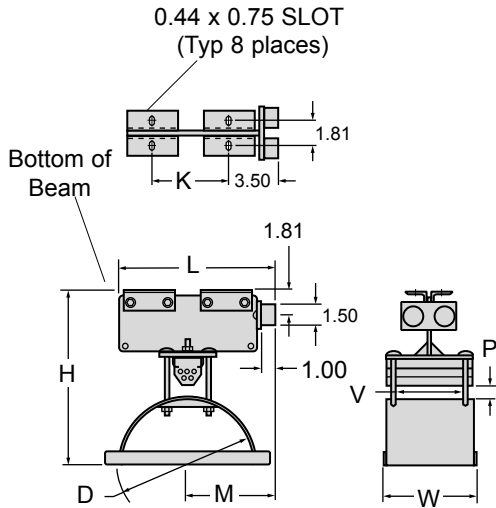

Model Number	Saddle Radius R	Saddle Dia. D	Window Height P	Window Width V	Overall Length L	Overall Width W	Below Beam H	Saddle Locator M	Bolts K
<i>w/ Std Hardware</i>									
I115-M04-2102E-Z	2.47	4.94	2.12	2.62	11.62	4.31	11.34	6.31	5.62
I115-M04-2105E-Z	2.47	4.94	2.12	5.00	11.62	6.69	11.34	6.31	5.62
I115-M04-2106E-Z	2.47	4.94	2.12	6.56	11.62	8.25	11.34	6.31	5.62
I115-M06-1402E-Z	3.16	6.31	1.44	2.62	11.62	4.31	12.66	6.31	5.62
I115-M06-1405E-Z	3.16	6.31	1.44	5.00	11.62	6.69	12.66	6.31	5.62
I115-M06-1406E-Z	3.16	6.31	1.44	6.56	11.62	8.25	12.66	6.31	5.62
I115-M06-2702E-Z	3.16	6.31	2.75	2.62	11.62	4.31	12.66	6.31	5.62
I115-M06-2705E-Z	3.16	6.31	2.75	5.00	11.62	6.69	12.66	6.31	5.62
I115-M06-2706E-Z	3.16	6.31	2.75	6.56	11.62	8.25	12.66	6.31	5.62
I115-M07-1905E-Z	3.94	7.88	1.97	5.00	11.62	6.69	12.66	6.31	5.62
I115-M07-1906E-Z	3.94	7.88	1.97	6.56	11.62	8.25	12.66	6.31	5.62
I115-M07-1908E-Z	3.94	7.88	1.97	8.56	11.62	10.25	12.66	6.31	5.62
I115-M07-3505E-Z	3.94	7.88	3.53	5.00	14.75	6.69	14.22	7.88	8.75
I115-M07-3506E-Z	3.94	7.88	3.53	6.56	14.75	8.25	14.22	7.88	8.75
I115-M07-3508E-Z	3.94	7.88	3.53	8.56	14.75	10.25	14.22	7.88	8.75
I115-M09-1005E-Z	4.94	9.88	1.00	5.00	11.62	6.69	12.69	6.31	5.62
I115-M09-1006E-Z	4.94	9.88	1.00	6.56	11.62	8.25	12.69	6.31	5.62
I115-M09-1008E-Z	4.94	9.88	1.00	8.56	11.62	10.25	12.69	6.31	5.62
I115-M09-2505E-Z	4.94	9.88	2.56	5.00	14.75	6.69	14.26	7.88	8.75
I115-M09-2506E-Z	4.94	9.88	2.56	6.56	14.75	8.25	14.26	7.88	8.75
I115-M09-2508E-Z	4.94	9.88	2.56	8.56	14.75	10.25	14.26	7.88	8.75
I115-M12-1105E-Z	6.30	12.59	1.18	5.00	14.75	6.69	14.26	7.88	8.75
I115-M12-1106E-Z	6.30	12.59	1.18	6.56	14.75	8.25	14.26	7.88	8.75
I115-M12-1108E-Z	6.30	12.59	1.18	8.56	14.75	10.25	14.26	7.88	8.75
I115-M12-3105E-Z	6.30	12.59	3.15	5.00	18.69	6.69	16.19	9.84	12.69
I115-M12-3106E-Z	6.30	12.59	3.15	6.56	18.69	8.25	16.19	9.84	12.69
I115-M12-3108E-Z	6.30	12.59	3.15	8.56	18.69	10.25	16.19	9.84	12.69

Fits all beam sizes.

Intermediate Trolley *Quantity as Required*

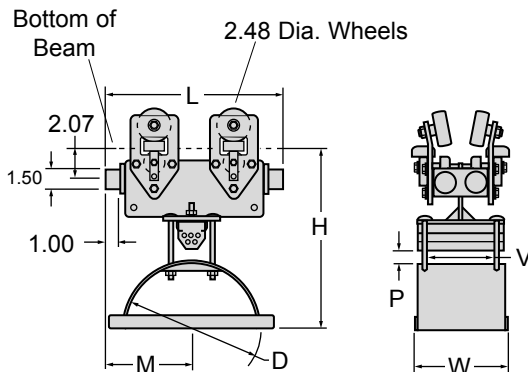

Model Number	Saddle Radius R	Saddle Dia. D	Window Height P	Window Width V	Overall Length L	Overall Width W	Below Beam H	Saddle Locator M
<i>w/ Std Hardware & Wheels</i>								
I115-M04-2102I-Z-SCP-®	2.47	4.94	2.12	2.62	10.06	4.31	11.60	5.03
I115-M04-2105I-Z-SCP-®	2.47	4.94	2.12	5.00	10.06	6.69	11.60	5.03
I115-M04-2106I-Z-SCP-®	2.47	4.94	2.12	6.56	10.06	8.25	11.60	5.03
I115-M06-1402I-Z-SCP-®	3.16	6.31	1.44	2.62	10.06	4.31	11.60	5.03
I115-M06-1405I-Z-SCP-®	3.16	6.31	1.44	5.00	10.06	6.69	11.60	5.03
I115-M06-1406I-Z-SCP-®	3.16	6.31	1.44	6.56	10.06	8.25	11.60	5.03
I115-M06-2702I-Z-SCP-®	3.16	6.31	2.75	2.62	12.62	4.31	12.91	6.31
I115-M06-2705I-Z-SCP-®	3.16	6.31	2.75	5.00	12.62	6.69	12.91	6.31
I115-M06-2706I-Z-SCP-®	3.16	6.31	2.75	6.56	12.62	8.25	12.91	6.31
I115-M07-1905I-Z-SCP-®	3.94	7.88	1.97	5.00	12.62	6.69	12.91	6.31
I115-M07-1906I-Z-SCP-®	3.94	7.88	1.97	6.56	12.62	8.25	12.91	6.31
I115-M07-1908I-Z-SCP-®	3.94	7.88	1.97	8.56	12.62	10.25	12.91	6.31
I115-M07-3505I-Z-SCP-®	3.94	7.88	3.53	5.00	15.75	6.69	14.47	7.88
I115-M07-3506I-Z-SCP-®	3.94	7.88	3.53	6.56	15.75	8.25	14.47	7.88
I115-M07-3508I-Z-SCP-®	3.94	7.88	3.53	8.56	15.75	10.25	14.47	7.88
I115-M09-1005I-Z-SCP-®	4.94	9.88	1.00	5.00	12.62	6.69	12.94	6.31
I115-M09-1006I-Z-SCP-®	4.94	9.88	1.00	6.56	12.62	8.25	12.94	6.31
I115-M09-1008I-Z-SCP-®	4.94	9.88	1.00	8.56	12.62	10.25	12.94	6.31
I115-M09-2505I-Z-SCP-®	4.94	9.88	2.56	5.00	15.75	6.69	14.51	7.88
I115-M09-2506I-Z-SCP-®	4.94	9.88	2.56	6.56	15.75	8.25	14.51	7.88
I115-M09-2508I-Z-SCP-®	4.94	9.88	2.56	8.56	15.75	10.25	14.51	7.88
I115-M12-1105I-Z-SCP-®	6.30	12.59	1.18	5.00	15.75	6.69	14.51	7.88
I115-M12-1106I-Z-SCP-®	6.30	12.59	1.18	6.56	15.75	8.25	14.51	7.88
I115-M12-1108I-Z-SCP-®	6.30	12.59	1.18	8.56	15.75	10.25	14.51	7.88
I115-M12-3105I-Z-SCP-®	6.30	12.59	3.15	5.00	19.69	6.69	16.45	9.84
I115-M12-3106I-Z-SCP-®	6.30	12.59	3.15	6.56	19.69	8.25	16.45	9.84
I115-M12-3108I-Z-SCP-®	6.30	12.59	3.15	8.56	19.69	10.25	16.45	9.84

Your beam size must be added to complete model number. See previous pages.

Series I115-M Components & Dimensions, con't.

For MIXED Cable or Hose

All dimensions in inches unless otherwise specified.

Tow Trolley *Standard...One Required*

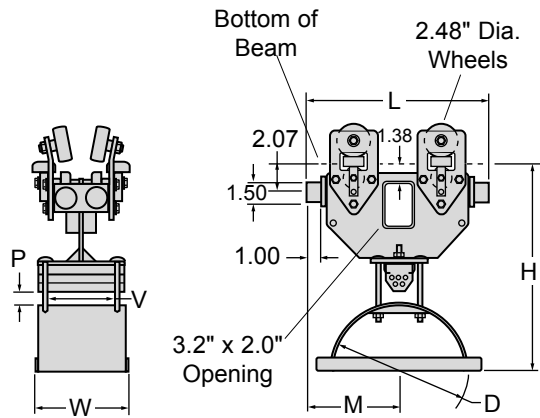

Model Number <small>w/ Std Hardware & Wheels</small>	Saddle Radius R	Saddle Dia. D	Window Height P	Window Width V	Overall Length L	Overall Width W	Below Beam H	Saddle Locator M
I115-M04-2102T-Z-SCP-®	2.47	4.94	2.12	2.62	12.62	4.31	13.60	6.31
I115-M04-2105T-Z-SCP-®	2.47	4.94	2.12	5.00	12.62	6.69	13.60	6.31
I115-M04-2106T-Z-SCP-®	2.47	4.94	2.12	6.56	12.62	8.25	13.60	6.31
I115-M06-1402T-Z-SCP-®	3.16	6.31	1.44	2.62	12.62	4.31	13.60	6.31
I115-M06-1405T-Z-SCP-®	3.16	6.31	1.44	5.00	12.62	6.69	13.60	6.31
I115-M06-1406T-Z-SCP-®	3.16	6.31	1.44	6.56	12.62	8.25	13.60	6.31
I115-M06-2702T-Z-SCP-®	3.16	6.31	2.75	2.62	12.62	4.31	14.91	6.31
I115-M06-2705T-Z-SCP-®	3.16	6.31	2.75	5.00	12.62	6.69	14.91	6.31
I115-M06-2706T-Z-SCP-®	3.16	6.31	2.75	6.56	12.62	8.25	14.91	6.31
I115-M07-1905T-Z-SCP-®	3.94	7.88	1.97	5.00	12.62	6.69	14.91	6.31
I115-M07-1906T-Z-SCP-®	3.94	7.88	1.97	6.56	12.62	8.25	14.91	6.31
I115-M07-1908T-Z-SCP-®	3.94	7.88	1.97	8.56	12.62	10.25	14.91	6.31
I115-M07-3505T-Z-SCP-®	3.94	7.88	3.53	5.00	15.75	6.69	16.47	7.88
I115-M07-3506T-Z-SCP-®	3.94	7.88	3.53	6.56	15.75	8.25	16.47	7.88
I115-M07-3508T-Z-SCP-®	3.94	7.88	3.53	8.56	15.75	10.25	16.47	7.88
I115-M09-1005T-Z-SCP-®	4.94	9.88	1.00	5.00	12.62	6.69	14.94	6.31
I115-M09-1006T-Z-SCP-®	4.94	9.88	1.00	6.56	12.62	8.25	14.94	6.31
I115-M09-1008T-Z-SCP-®	4.94	9.88	1.00	8.56	12.62	10.25	14.94	6.31
I115-M09-2505T-Z-SCP-®	4.94	9.88	2.56	5.00	15.75	6.69	16.51	7.88
I115-M09-2506T-Z-SCP-®	4.94	9.88	2.56	6.56	15.75	8.25	16.51	7.88
I115-M09-2508T-Z-SCP-®	4.94	9.88	2.56	8.56	15.75	10.25	16.51	7.88
I115-M12-1105T-Z-SCP-®	6.30	12.59	1.18	5.00	15.75	6.69	16.51	7.88
I115-M12-1106T-Z-SCP-®	6.30	12.59	1.18	6.56	15.75	8.25	16.51	7.88
I115-M12-1108T-Z-SCP-®	6.30	12.59	1.18	8.56	15.75	10.25	16.51	7.88
I115-M12-3105T-Z-SCP-®	6.30	12.59	3.15	5.00	19.69	6.69	18.45	9.84
I115-M12-3106T-Z-SCP-®	6.30	12.59	3.15	6.56	19.69	8.25	18.45	9.84
I115-M12-3108T-Z-SCP-®	6.30	12.59	3.15	8.56	19.69	10.25	18.45	9.84

Your beam size must be added to complete model number. See previous pages.

Tow Clamp *Optional...Replaces Tow Trolley (one required)*

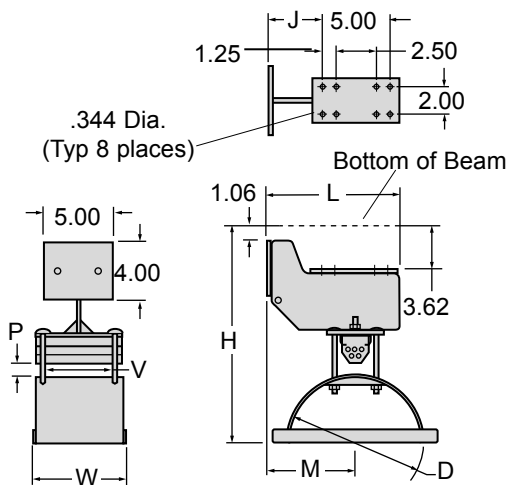

Model Number <small>w/ Std Hardware</small>	Saddle Radius R	Saddle Dia. D	Window Height P	Window Width V	Overall Length L	Overall Width W	Below Beam H	Saddle Locator M	Mtg. Locator J
I115-M04-2102C-Z	2.47	4.94	2.12	2.62	9.28	4.31	15.09	5.91	3.41
I115-M04-2105C-Z	2.47	4.94	2.12	5.00	9.28	6.69	15.09	5.91	3.41
I115-M04-2106C-Z	2.47	4.94	2.12	6.56	9.28	8.25	15.09	5.91	3.41
I115-M06-1402C-Z	3.16	6.31	1.44	2.62	9.28	4.31	16.40	5.91	3.41
I115-M06-1405C-Z	3.16	6.31	1.44	5.00	9.28	6.69	16.40	5.91	3.41
I115-M06-1406C-Z	3.16	6.31	1.44	6.56	9.28	8.25	16.40	5.91	3.41
I115-M06-2702C-Z	3.16	6.31	2.75	2.62	9.28	4.31	16.40	5.91	3.41
I115-M06-2705C-Z	3.16	6.31	2.75	5.00	9.28	6.69	16.40	5.91	3.41
I115-M06-2706C-Z	3.16	6.31	2.75	6.56	9.28	8.25	16.40	5.91	3.41
I115-M07-1905C-Z	3.94	7.88	1.97	5.00	9.28	6.69	16.40	5.91	3.41
I115-M07-1906C-Z	3.94	7.88	1.97	6.56	9.28	8.25	16.40	5.91	3.41
I115-M07-1908C-Z	3.94	7.88	1.97	8.56	9.28	10.25	16.40	5.91	3.41
I115-M07-3505C-Z	3.94	7.88	3.53	5.00	12.81	6.69	17.97	9.44	6.94
I115-M07-3506C-Z	3.94	7.88	3.53	6.56	12.81	8.25	17.97	9.44	6.94
I115-M07-3508C-Z	3.94	7.88	3.53	8.56	12.81	10.25	17.97	9.44	6.94
I115-M09-1005C-Z	4.94	9.88	1.00	5.00	9.28	6.69	16.44	5.91	3.41
I115-M09-1006C-Z	4.94	9.88	1.00	6.56	9.28	8.25	16.44	5.91	3.41
I115-M09-1008C-Z	4.94	9.88	1.00	8.56	9.28	10.25	16.44	5.91	3.41
I115-M09-2505C-Z	4.94	9.88	2.56	5.00	12.81	6.69	18.00	9.44	6.94
I115-M09-2506C-Z	4.94	9.88	2.56	6.56	12.81	8.25	18.00	9.44	6.94
I115-M09-2508C-Z	4.94	9.88	2.56	8.56	12.81	10.25	18.00	9.44	6.94
I115-M12-1105C-Z	6.30	12.59	1.18	5.00	12.81	6.69	19.94	9.44	6.94
I115-M12-1106C-Z	6.30	12.59	1.18	6.56	12.81	8.25	19.94	9.44	6.94
I115-M12-1108C-Z	6.30	12.59	1.18	8.56	12.81	10.25	19.94	9.44	6.94
I115-M12-3105C-Z	6.30	12.59	3.15	5.00	12.81	6.69	19.94	9.44	6.94
I115-M12-3106C-Z	6.30	12.59	3.15	6.56	12.81	8.25	19.94	9.44	6.94
I115-M12-3108C-Z	6.30	12.59	3.15	8.56	12.81	10.25	19.94	9.44	6.94

Fits all beam sizes.

GLEASON Beam·Master™ SERIES I120-s Single Clamp

- FLAT, ROUND OR MIXED CABLE/HOSE
- CROWNED 2.48" DIA. STEEL WHEELS STANDARD
- ANTI-LIFT ROLLERS STANDARD
- SEALED BALL BEARINGS STANDARD

- MAX SADDLE DIAMETER = 18.12"
- MAX TROLLEY LOAD = 450 lbs.
- TRAVEL SPEEDS TO 500 fpm
- ACCELERATION—Consult us if over 2.0 ft/sec².
- TRAVEL LENGTHS UNLIMITED

Standard Trolley Design

- Crowned 2.48" steel wheels with side guide rollers
- Anti-lift rollers
- Sealed bearings are pre-lubricated for life
- Tow trolley included as standard
- Zinc plated hardware
- Orange baked polyester powder finish
- Heavy duty bumpers
- Typical mounting on S5 or larger beams (S3 or larger with optional flanged wheels)— contact us for special situations
- Cable clamp allows cable pkg height to vary up to 0.63"

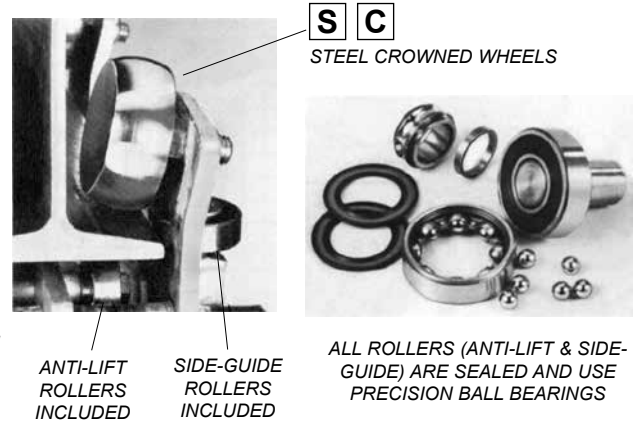

Model Number Explained

For STANDARD DESIGN, specific model numbers are on the following page.

Standard Intermediate Trolley*							Standard	Std. Wheels***	Your Beam	
TYPE	CLAMP STYLE	SADDLE DIAMETER	WINDOW HEIGHT	WINDOW WIDTH	ITEM	FINISH	WHEEL MAT'L	WHEEL STYLE	WHEEL LUBE	
#I120	S	06	- 30	040	I	Z	S	C	P-	
Chosen by computer						ZINC HARDWARE PAINTED TROLLEY	STEEL CROWNED PRE-LUB			
Options you select						Options	Wheel Options			
						S (STAINLESS)	G (GALVANIZED)	N (NYLON)	F (FLANGED)	G (REGREASE)
						Minimum Beam Height = 5.0" (3" with optional flanged wheels)				

* Example above is for INTERMEDIATE TROLLEY (I)
Use same option changes (at right) for other components as required

Optional Design Features

CODE	OPTION
F	FLANGED (STEEL ONLY) WHEELS WITH ANTI-LIFT ROLLERS
N	CROWNED NYLON WHEELS WITH SIDE GUIDE ROLLERS
G	RE-GREASABLE BEARINGS ON MAIN WHEELS
S	STAINLESS STEEL HARDWARE
	OTHER FINISHES AVAILABLE – PLEASE CONTACT US
	PRE-ASSEMBLY ON SHIPPING FRAME AVAILABLE

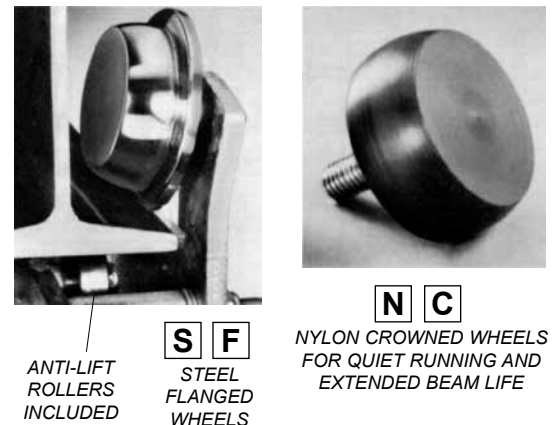

Accessories

See detail pages at back of catalog

- CABLE CLAMPS
- SHOCK CORDS
- CABLE, ROUND OR FLAT; HOSE
- TERMINAL BOX(ES)
- TY-RAPS
- CABLE GLANDS FOR SINGLE CABLES OR GROUPS
- TOW ROPES
- TERMINAL BLOCKS

Series I120-s Components & Dimensions

Single Clamp Design—Contact us for multiple tier requirements

All dimensions in inches unless otherwise specified.

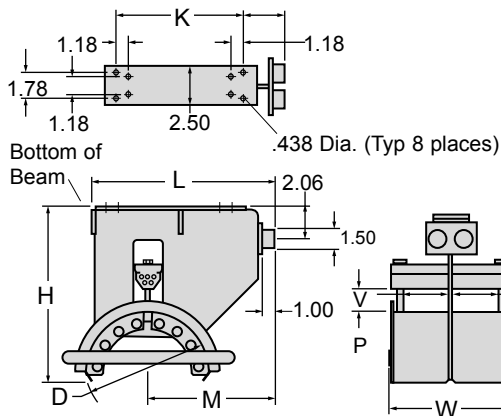

End Clamp *One Required*

Model Number w/ Std Hardware	Saddle Radius R	Saddle Dia. D	Window Height P	Window Width* V	Overall Length L	Overall Width W	Below Beam H	Saddle Locator M	Mtg. Locator J	Bolts K
I120-S06-3004E-Z	3.16	6.31	3.00	4.38	10.38	11.44	10.85	6.93	3.63	5.50
I120-S06-3006E-Z	3.16	6.31	3.00	6.19	10.38	15.06	10.85	6.93	3.63	5.50
I120-S10-1004E-Z	5.13	10.25	1.06	4.38	11.44	11.44	10.85	8.00	3.50	6.69
I120-S10-1006E-Z	5.13	10.25	1.06	6.19	11.44	15.06	10.85	8.00	3.50	6.69
I120-S10-3304E-Z	5.13	10.25	3.38	4.38	12.75	11.44	13.22	9.31	4.81	6.69
I120-S10-3306E-Z	5.13	10.25	3.38	6.19	12.75	15.06	13.22	9.31	4.81	6.69
I120-S14-1404E-Z	7.06	14.12	1.44	4.38	15.31	11.44	13.22	10.72	3.44	10.63
I120-S14-1406E-Z	7.06	14.12	1.44	6.19	15.31	15.06	13.22	10.72	3.44	10.63
I120-S18-1804E-Z	9.06	18.12	1.81	4.38	18.63	11.44	16.09	13.47	3.19	14.19
I120-S18-1806E-Z	9.06	18.12	1.81	6.19	18.63	15.06	16.09	13.47	3.19	14.19

Fits all beam sizes.

* Window width each side of frame plate.

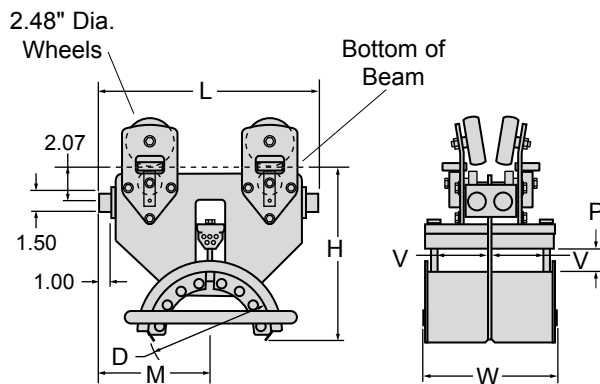

Intermediate Trolley *Quantity as Required*

Model Number w/ Std Hardware & Wheels	Saddle Radius R	Saddle Dia. D	Window Height P	Window Width* V	Overall Length L	Overall Width W	Below Beam H	Saddle Locator M
I120-S06-3004I-Z-SCP-®	3.16	6.31	3.00	4.38	13.12	11.44	10.69	6.56
I120-S06-3006I-Z-SCP-®	3.16	6.31	3.00	6.19	13.12	15.06	10.69	6.56
I120-S10-1004I-Z-SCP-®	5.13	10.25	1.06	4.38	13.12	11.44	10.69	6.56
I120-S10-1006I-Z-SCP-®	5.13	10.25	1.06	6.19	13.12	15.06	10.69	6.56
I120-S10-3304I-Z-SCP-®	5.13	10.25	3.38	4.38	17.88	11.44	13.07	8.94
I120-S10-3306I-Z-SCP-®	5.13	10.25	3.38	6.19	17.88	15.06	13.07	8.94
I120-S14-1404I-Z-SCP-®	7.06	14.12	1.44	4.38	17.88	11.44	13.07	8.94
I120-S14-1406I-Z-SCP-®	7.06	14.12	1.44	6.19	17.88	15.06	13.07	8.94
I120-S18-1804I-Z-SCP-®	9.06	18.12	1.81	4.38	22.59	11.44	15.94	11.29
I120-S18-1806I-Z-SCP-®	9.06	18.12	1.81	6.19	22.59	15.06	15.94	11.29

Your beam size must be added to complete model number. See previous pages.

* Window width each side of frame plate.

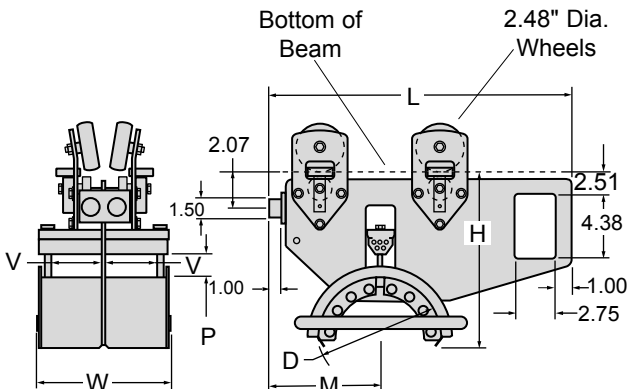

Tow Trolley *Standard...One Required*

Model Number w/ Std Hardware & Wheels	Saddle Radius R	Saddle Dia. D	Window Height P	Window Width* V	Overall Length L	Overall Width W	Below Beam H	Saddle Locator M
I120-S06-3004T-Z-SCP-®	3.16	6.31	3.00	4.38	15.31	11.44	10.69	6.97
I120-S06-3006T-Z-SCP-®	3.16	6.31	3.00	6.19	15.31	15.06	10.69	6.97
I120-S10-1004T-Z-SCP-®	5.13	10.25	1.06	4.38	16.75	11.44	10.69	7.59
I120-S10-1006T-Z-SCP-®	5.13	10.25	1.06	6.19	16.75	15.06	10.69	7.59
I120-S10-3304T-Z-SCP-®	5.13	10.25	3.38	4.38	20.19	11.44	13.07	8.94
I120-S10-3306T-Z-SCP-®	5.13	10.25	3.38	6.19	20.19	15.06	13.07	8.94
I120-S14-1404T-Z-SCP-®	7.06	14.12	1.44	4.38	22.19	11.44	13.07	10.31
I120-S14-1406T-Z-SCP-®	7.06	14.12	1.44	6.19	22.19	15.06	13.07	10.31
I120-S18-1804T-Z-SCP-®	9.06	18.12	1.81	4.38	25.50	11.44	15.94	13.09
I120-S18-1806T-Z-SCP-®	9.06	18.12	1.81	6.19	25.50	15.06	15.94	13.09

Your beam size must be added to complete model number. See previous pages.

* Window width each side of frame plate.

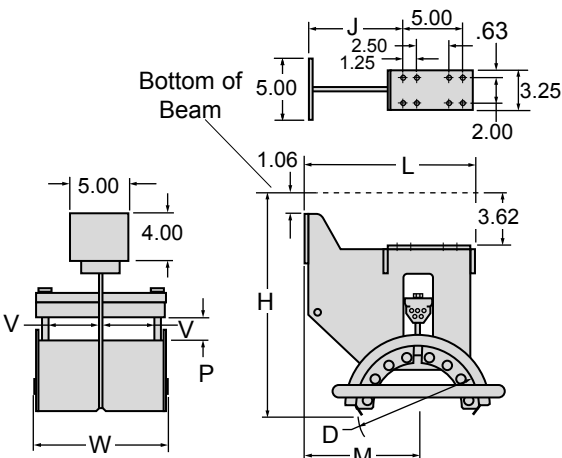

Tow Clamp *Optional...Replaces Tow Trolley (one required)*

Model Number w/ Std Hardware	Saddle Radius R	Saddle Dia. D	Window Height P	Window Width* V	Overall Length L	Overall Width W	Below Beam H	Saddle Locator M	Mtg. Locator J
I120-S06-3004C-Z	3.16	6.31	3.00	4.38	10.63	11.44	14.25	7.19	4.69
I120-S06-3006C-Z	3.16	6.31	3.00	6.19	10.63	15.06	14.25	7.19	4.69
I120-S10-1004C-Z	5.13	10.25	1.06	4.38	10.63	11.44	14.25	7.19	4.69
I120-S10-1006C-Z	5.13	10.25	1.06	6.19	10.63	15.06	14.25	7.19	4.69
I120-S10-3304C-Z	5.13	10.25	3.38	4.38	11.91	11.44	16.44	8.44	5.94
I120-S10-3306C-Z	5.13	10.25	3.38	6.19	11.91	15.06	16.44	8.44	5.94
I120-S14-1404C-Z	7.06	14.12	1.44	4.38	14.50	11.44	16.62	9.94	7.44
I120-S14-1406C-Z	7.06	14.12	1.44	6.19	14.50	15.06	16.62	9.94	7.44
I120-S18-1804C-Z	9.06	18.12	1.81	4.38	17.84	11.44	19.50	12.69	10.19
I120-S18-1806C-Z	9.06	18.12	1.81	6.19	17.84	15.06	19.50	12.69	10.19

Fits all beam sizes.

* Window width each side of frame plate.

GLEASON **Beam·Master**™ SERIES **I120-D**

Dual Clamp

- FLAT, ROUND OR MIXED CABLE/HOSE
- CROWNED 2.48" DIA. STEEL WHEELS STANDARD
- ANTI-LIFT ROLLERS STANDARD
- SEALED BALL BEARINGS STANDARD

- MAX SADDLE DIAMETER = 18.12"
- MAX TROLLEY LOAD = 450 lbs.
- TRAVEL SPEEDS TO 500 fpm
- ACCELERATION—Consult us if over 2.0 ft/sec².
- TRAVEL LENGTHS UNLIMITED

Standard Trolley Design

- **Crowned 2.48" steel wheels with side guide rollers.**
- **Anti-lift rollers**
- **Sealed bearings are pre-lubricated for life**
- **Tow trolley included as standard**
- **Zinc plated hardware**
- **Orange baked polyester powder finish**
- **Heavy duty bumpers**
- **Typical mounting on S5 or larger beams (S3 or larger with optional flanged wheels)— contact us for special situations**
- **Cable clamp allows cable pkg height to vary up to 0.63"**

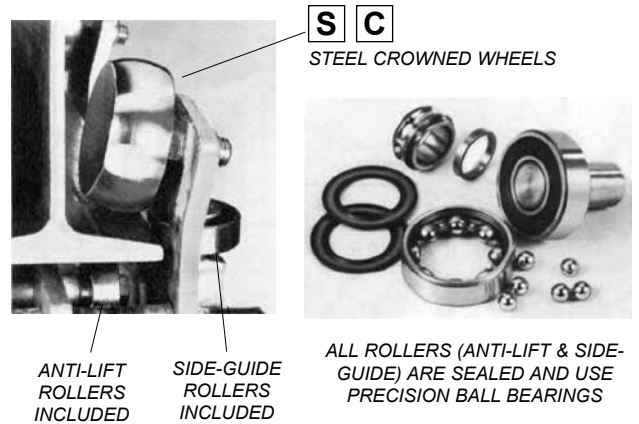

Model Number Explained

For STANDARD DESIGN, specific model numbers are on the following page.

Standard Intermediate Trolley*							Standard	Std. Wheels***	Your Beam					
TYPE	CLAMP STYLE	SADDLE DIAMETER	WINDOW HEIGHT	WINDOW WIDTH	ITEM	FINISH	WHEEL MAT'L	WHEEL STYLE	WHEEL LUBE					
#I120	D	06	- 30	07	I	Z - ZINC HARDWARE PAINTED TROLLEY	S C P -	STEEL CROWNED	PRE-LUB					
Chosen by computer			Options you select				Options	Wheel Options						
							S STAINLESS	G GALVANIZED	N NYLON	F FLANGED	G REGREASE	Minimum Beam Height = 5.0" (3" with optional flanged wheels)		

* Example above is for INTERMEDIATE TROLLEY (I)
Use same option changes (at right) for other components as required

Optional Design Features

CODE	OPTION
F	FLANGED (STEEL ONLY) WHEELS WITH ANTI-LIFT ROLLERS
N	CROWNED NYLON WHEELS WITH SIDE GUIDE ROLLERS
G	RE-GREASABLE BEARINGS ON MAIN WHEELS
S	STAINLESS STEEL HARDWARE
	OTHER FINISHES AVAILABLE – PLEASE CONTACT US
	PRE-ASSEMBLY ON SHIPPING FRAME AVAILABLE

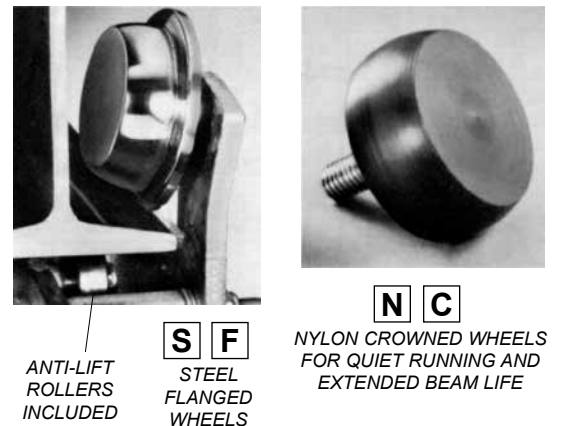

Accessories

See detail pages at back of catalog

- CABLE CLAMPS
- SHOCK CORDS
- CABLE, ROUND OR FLAT; HOSE
- TERMINAL BOX(ES)
- TY-RAPS
- CABLE GLANDS FOR SINGLE CABLES OR GROUPS
- TOW ROPES
- TERMINAL BLOCKS

Series I120-D Components & Dimensions

For MIXED Cable or Hose

All dimensions in inches unless otherwise specified.

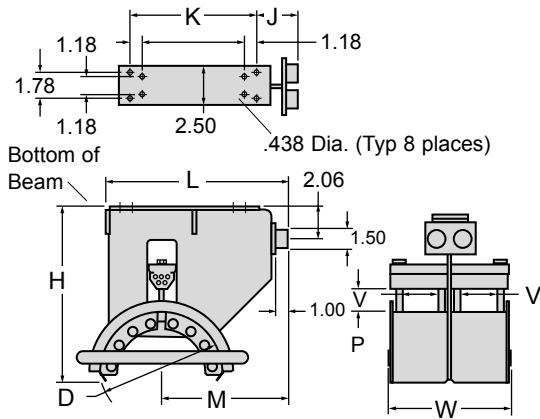

End Clamp *One Required*

Model Number w/ Std Hardware	Saddle Radius R	Saddle Dia. D	Window Height P	Window Width* V	Overall Length L	Overall Width W	Below Beam H	Saddle Locator M	Mtg. Locator J	Bolts K
I120-D06-3007E-Z	3.16	6.31	3.00	7.88	10.38	20.44	10.85	6.93	3.63	5.50
I120-D10-1007E-Z	5.13	10.25	1.06	7.88	11.44	20.44	10.85	8.00	3.50	6.69
I120-D10-1012E-Z	5.13	10.25	1.06	12.69	11.44	30.06	10.85	8.00	3.50	6.69
I120-D10-3307E-Z	5.13	10.25	3.38	7.88	12.75	20.44	13.22	9.31	4.81	6.69
I120-D14-1407E-Z	7.06	14.12	1.44	7.88	15.31	20.44	13.22	10.72	3.44	10.63
I120-D14-1412E-Z	7.06	14.12	1.44	12.69	15.31	30.06	13.22	10.72	3.44	10.63
I120-D18-1807E-Z	9.06	18.12	1.81	7.88	18.63	20.44	16.09	13.47	3.19	14.19
I120-D18-1812E-Z	9.06	18.12	1.81	12.69	18.63	30.06	16.09	13.47	3.19	14.19

Fits all beam sizes. * Window width each side.

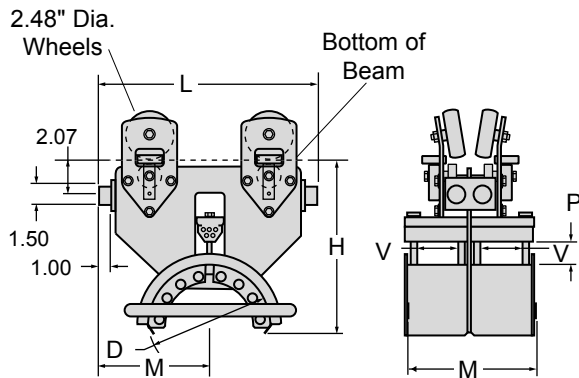

Intermediate Trolley *Quantity as Required*

Model Number w/ Std Hardware & Wheels	Saddle Radius R	Saddle Dia. D	Window Height P	Window Width* V	Overall Length L	Overall Width W	Below Beam H	Saddle Locator M
I120-D06-3007L-Z-SCP-®	3.16	6.31	3.00	7.88	13.12	20.44	10.69	6.56
I120-D10-1007L-Z-SCP-®	5.13	10.25	1.06	7.88	13.12	20.44	10.69	6.56
I120-D10-1012L-Z-SCP-®	5.13	10.25	1.06	12.69	13.12	30.06	10.69	6.56
I120-D10-3307L-Z-SCP-®	5.13	10.25	3.38	7.88	17.88	20.44	13.07	8.94
I120-D14-1407L-Z-SCP-®	7.06	14.25	1.44	7.88	17.88	20.44	13.07	8.94
I120-D14-1412L-Z-SCP-®	7.06	14.25	1.44	12.69	17.88	30.06	13.07	8.94
I120-D18-1807L-Z-SCP-®	9.06	18.25	1.81	7.88	22.59	20.44	15.94	11.29
I120-D18-1812L-Z-SCP-®	9.06	18.25	1.81	12.69	22.59	30.06	15.94	11.29

Your beam size must be added to complete model number. See previous pages.

* Window width each side.

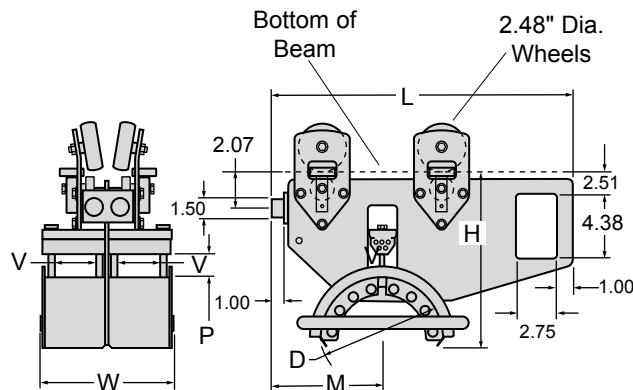

Tow Trolley *Standard...One Required*

Model Number w/ Std Hardware & Wheels	Saddle Radius R	Saddle Dia. D	Window Height P	Window Width* V	Overall Length L	Overall Width W	Below Beam H	Saddle Locator M
I120-D06-3007T-Z-SCP-®	3.16	6.31	3.00	7.88	15.31	20.44	10.69	6.97
I120-D10-1007T-Z-SCP-®	5.13	10.25	1.06	7.88	16.75	20.44	10.69	7.59
I120-D10-1012T-Z-SCP-®	5.13	10.25	1.06	12.69	16.75	30.06	10.69	7.59
I120-D10-3307T-Z-SCP-®	5.13	10.25	3.38	7.88	20.19	20.44	13.07	8.94
I120-D14-1407T-Z-SCP-®	7.06	14.12	1.44	7.88	22.19	20.44	13.07	10.31
I120-D14-1412T-Z-SCP-®	7.06	14.12	1.44	12.69	22.19	30.06	13.07	10.31
I120-D18-1807T-Z-SCP-®	9.06	18.12	1.81	7.88	25.50	20.44	15.94	13.09
I120-D18-1812T-Z-SCP-®	9.06	18.12	1.81	12.69	25.50	30.06	15.94	13.09

Your beam size must be added to complete model number. See previous pages.

* Window width each side of frame plate.

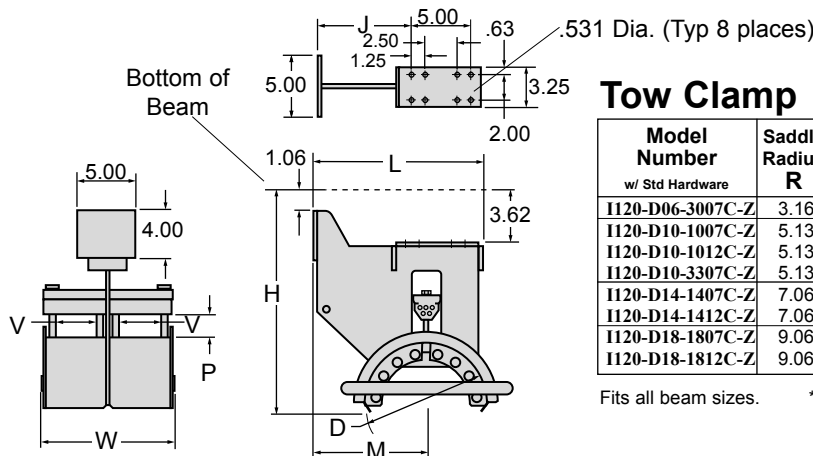

Tow Clamp *Optional...Replaces Tow Trolley (one required)*

Model Number w/ Std Hardware	Saddle Radius R	Saddle Dia. D	Window Height P	Window Width* V	Overall Length L	Overall Width W	Below Beam H	Saddle Locator M	Mtg. Locator J
I120-D06-3007C-Z	3.16	6.31	3.00	7.88	10.63	20.44	14.25	7.19	4.69
I120-D10-1007C-Z	5.13	10.25	1.06	7.88	10.63	20.44	14.25	7.19	4.69
I120-D10-1012C-Z	5.13	10.25	1.06	12.69	10.63	30.06	14.25	7.19	4.69
I120-D10-3307C-Z	5.13	10.25	3.38	7.88	11.91	20.44	16.44	8.44	5.94
I120-D14-1407C-Z	7.06	14.12	1.44	7.88	14.50	20.44	16.62	9.94	7.44
I120-D14-1412C-Z	7.06	14.12	1.44	12.69	14.50	30.06	16.62	9.94	7.44
I120-D18-1807C-Z	9.06	18.12	1.81	7.88	17.84	20.44	19.50	12.69	10.19
I120-D18-1812C-Z	9.06	18.12	1.81	12.69	17.84	30.06	19.50	12.69	10.19

Fits all beam sizes. * Window width each side of frame plate.

GLEASON **Beam·Master**™ SERIES **I130-s**

Single Clamp

- FLAT, ROUND OR MIXED CABLE/HOSE
- CROWNED 4" DIA. STEEL WHEELS STANDARD
- ANTI-LIFT ROLLERS STANDARD
- SEALED BALL BEARINGS STANDARD

- MAX SADDLE DIAMETER = 18.12"
- MAX TROLLEY LOAD = 700 lbs.
- TRAVEL SPEEDS TO 650 fpm
- ACCELERATION—Consult us if over 2.0 ft/sec².
- TRAVEL LENGTHS UNLIMITED

Standard Trolley Design

- **Crowned 4" steel wheels with side guide rollers.**
- **Anti-lift rollers**
- **Sealed bearings are pre-lubricated for life**
- **Tow trolley included as standard**
- **Zinc plated hardware**
- **Orange baked polyester powder finish**
- **Heavy duty bumpers**
- **Typical mounting on S5 or larger beams— contact us for special situations**
- **Cable clamp allows cable pkg height to vary up to 0.63"**

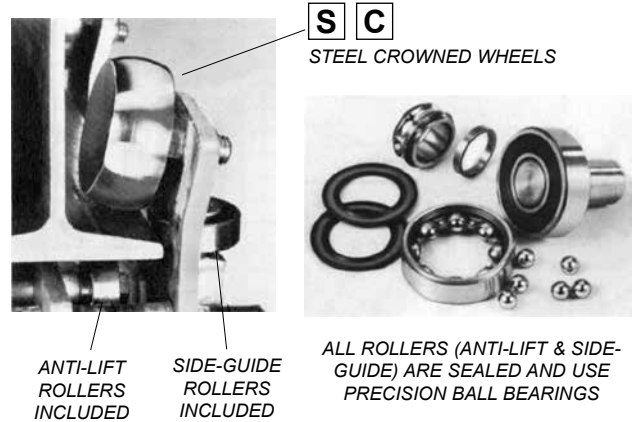

Model Number Explained

For STANDARD DESIGN, specific model numbers are on the following page.

Standard Intermediate Trolley*							Standard	Std. Wheels***	Your Beam		
TYPE	CLAMP STYLE	SADDLE DIAMETER	WINDOW HEIGHT	WINDOW WIDTH	ITEM	FINISH	WHEEL MAT'L	WHEEL STYLE	WHEEL LUBE		
#I130	S	10	-	33	04	I	Z	S	C	P	□ □ □ x □ □ □ . □
Chosen by computer						Options		Wheel Options			Minimum Beam Height = 5.0"
Options you select						S STAIN-LESS	G GALVA-NIZED	N NYLON	F FLANGED	G REGREASE	

* Example above is for INTERMEDIATE TROLLEY (I)
Use same option changes (at right) for other components as required

Optional Design Features

CODE	OPTION
F	FLANGED (STEEL ONLY) WHEELS WITH ANTI-LIFT ROLLERS
N	CROWNED NYLON WHEELS WITH SIDE GUIDE ROLLERS
G	RE-GREASABLE BEARINGS ON MAIN WHEELS
S	STAINLESS STEEL HARDWARE
□	OTHER FINISHES AVAILABLE – PLEASE CONTACT US
□	PRE-ASSEMBLY ON SHIPPING FRAME AVAILABLE

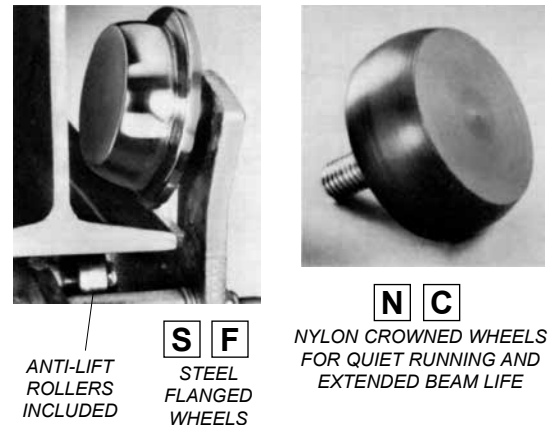

Accessories

See detail pages at back of catalog

- CABLE CLAMPS
- SHOCK CORDS
- CABLE, ROUND OR FLAT; HOSE
- TERMINAL BOX(ES)
- TY-RAPS
- CABLE GLANDS FOR SINGLE CABLES OR GROUPS
- TOW ROPES
- TERMINAL BLOCKS

Series I130-s Components & Dimensions

Single Clamp Design—Contact us for multiple tier requirements

All dimensions in inches unless otherwise specified.

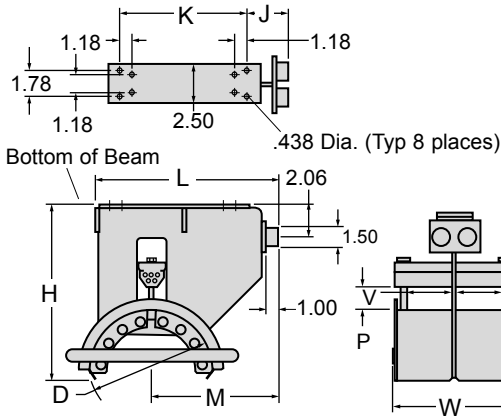

End Clamp *One Required*

Model Number w/ Std Hardware	Saddle Radius R	Saddle Dia. D	Window Height P	Window Width* V	Overall Length L	Overall Width W	Below Beam H	Saddle Locator M	Mtg. Locator J	Bolts K
I130-S10-3304E-Z	5.13	10.25	3.38	4.38	12.75	11.44	13.22	9.31	4.81	6.69
I130-S10-3306E-Z	5.13	10.25	3.38	6.19	12.75	15.06	13.22	9.31	4.81	6.69
I130-S14-1404E-Z	7.06	14.12	1.44	4.38	15.31	11.44	13.22	10.72	3.44	10.63
I130-S14-1406E-Z	7.06	14.12	1.44	6.19	15.31	15.06	13.22	10.72	3.44	10.63
I130-S18-1804E-Z	9.06	18.12	1.81	4.38	18.63	11.44	16.09	13.47	3.19	14.19
I130-S18-1806E-Z	9.06	18.12	1.81	6.19	18.63	15.06	16.09	13.47	3.19	14.19

Fits all beam sizes.

* Window width each side of frame plate.

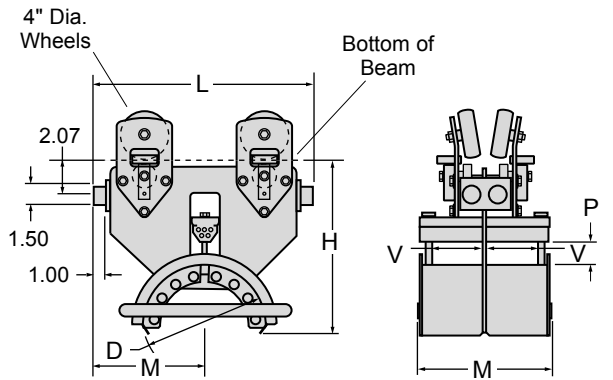

Intermediate Trolley *Quantity as Required*

Model Number w/ Std Hardware & Wheels	Saddle Radius R	Saddle Dia. D	Window Height P	Window Width* V	Overall Length L	Overall Width W	Below Beam H	Saddle Locator M
I130-S10-3304I-Z-SCP-®	5.13	10.25	3.38	4.38	17.88	11.44	13.07	8.94
I130-S10-3306I-Z-SCP-®	5.13	10.25	3.38	6.19	17.88	15.06	13.07	8.94
I130-S14-1404I-Z-SCP-®	7.06	14.12	1.44	4.38	17.88	11.44	13.07	8.94
I130-S14-1406I-Z-SCP-®	7.06	14.12	1.44	6.19	17.88	15.06	13.07	8.94
I130-S18-1804I-Z-SCP-®	9.06	18.12	1.81	4.38	22.59	11.44	15.94	11.29
I130-S18-1806I-Z-SCP-®	9.06	18.12	1.81	6.19	22.59	15.06	15.94	11.29

Your beam size must be added to complete model number. See previous pages.

* Window width each side of frame plate.

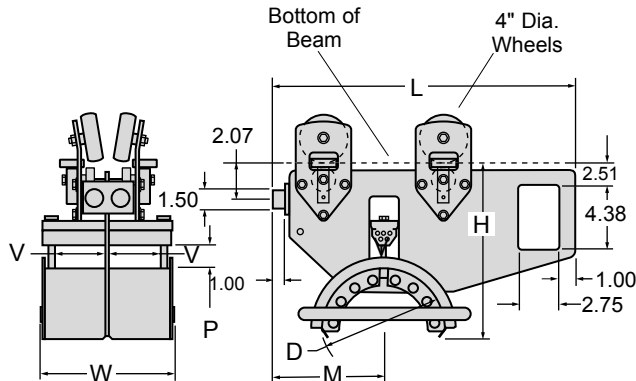

Tow Trolley *Standard...One Required*

Model Number w/ Std Hardware & Wheels	Saddle Radius R	Saddle Dia. D	Window Height P	Window Width* V	Overall Length L	Overall Width W	Below Beam H	Saddle Locator M
I130-S10-3304T-Z-SCP-®	5.13	10.25	3.38	4.38	20.19	11.44	13.07	8.94
I130-S10-3306T-Z-SCP-®	5.13	10.25	3.38	6.19	20.19	15.06	13.07	8.94
I130-S14-1404T-Z-SCP-®	7.06	14.12	1.44	4.38	22.19	11.44	13.07	10.31
I130-S14-1406T-Z-SCP-®	7.06	14.12	1.44	6.19	22.19	15.06	13.07	10.31
I130-S18-1804T-Z-SCP-®	9.06	18.12	1.81	4.38	25.50	11.44	15.94	13.09
I130-S18-1806T-Z-SCP-®	9.06	18.12	1.81	6.19	25.50	15.06	15.94	13.09

Your beam size must be added to complete model number. See previous pages.

* Window width each side of frame plate.

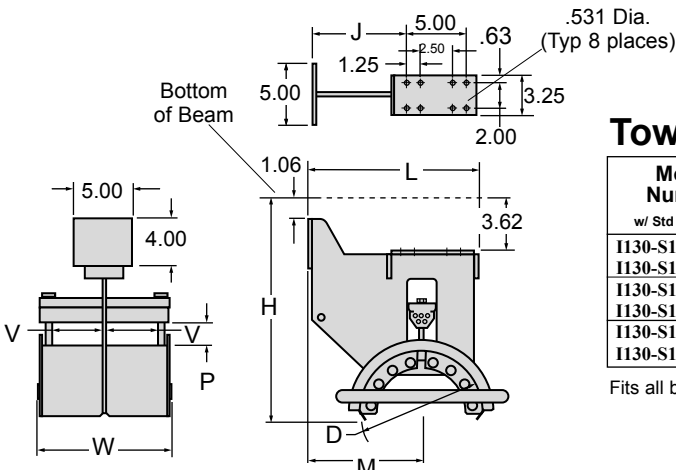

Tow Clamp *Optional...Replaces Tow Trolley (one required)*

Model Number w/ Std Hardware	Saddle Radius R	Saddle Dia. D	Window Height P	Window Width* V	Overall Length L	Overall Width W	Below Beam H	Saddle Locator M	Mtg. Locator J
I130-S10-3304C-Z	5.13	10.25	3.38	4.38	11.91	11.44	16.44	8.44	5.94
I130-S10-3306C-Z	5.13	10.25	3.38	6.19	11.91	15.06	16.44	8.44	5.94
I130-S14-1404C-Z	7.06	14.12	1.44	4.38	14.50	11.44	16.62	9.94	7.44
I130-S14-1406C-Z	7.06	14.12	1.44	6.19	14.50	15.06	16.62	9.94	7.44
I130-S18-1804C-Z	9.06	18.12	1.81	4.38	17.84	11.44	19.50	12.69	10.19
I130-S18-1806C-Z	9.06	18.12	1.81	6.19	17.84	15.06	19.50	12.69	10.19

Fits all beam sizes.

* Window width each side of frame plate.

GLEASON Beam·Master™ SERIES I130-D Dual Clamp

- FLAT, ROUND OR MIXED CABLE/HOSE
- CROWNED 4" DIA. STEEL WHEELS STANDARD
- ANTI-LIFT ROLLERS STANDARD
- SEALED BALL BEARINGS STANDARD

- MAX SADDLE DIAMETER = 18.12"
- MAX TROLLEY LOAD = 700 lbs.
- TRAVEL SPEEDS TO 650 fpm
- ACCELERATION—Consult us if over 2.0 ft/sec².
- TRAVEL LENGTHS UNLIMITED

Standard Trolley Design

- Crowned 4" steel wheels with side guide rollers.
- Anti-lift rollers
- Sealed bearings are pre-lubricated for life
- Tow trolley included as standard
- Zinc plated hardware
- Orange baked polyester powder finish
- Heavy duty bumpers
- Typical mounting on S5 or larger beams – contact us for special situations
- Cable clamp allows cable pkg height to vary up to 0.63"

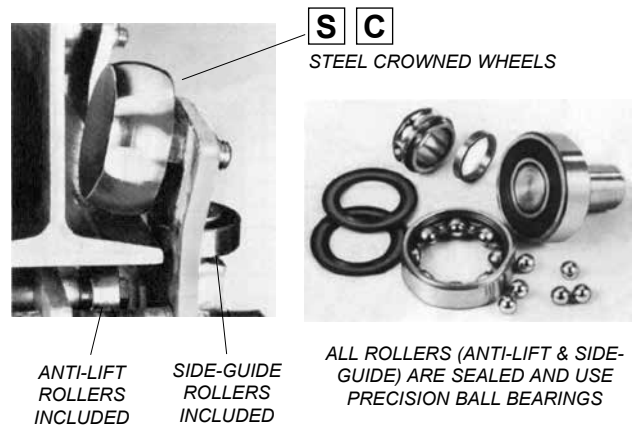

Model Number Explained

For STANDARD DESIGN, specific model numbers are on the following page.

Standard Intermediate Trolley*							Standard	Std. Wheels***	Your Beam			
TYPE	CLAMP STYLE	SADDLE DIAMETER	WINDOW HEIGHT	WINDOW WIDTH	ITEM	FINISH	WHEEL MAT'L	WHEEL STYLE	WHEEL LUBE			
#I130	D	10	-	33	07	I	Z	S	C	P	□ □ □ x □ □ □ . □ □ □	
Chosen by computer						Options you select						
* Example above is for INTERMEDIATE TROLLEY (I) Use same option changes (at right) for other components as required							ZINC HARDWARE PAINTED TROLLEY		STEEL CROWNED PRE-LUB		Minimum Beam Height = 8.0"	
							Options		Wheel Options			
							S STAINLESS G GALVANIZED		N NYLON F FLANGED G REGREASE			

Optional Design Features

CODE	OPTION
F	FLANGED (STEEL ONLY) WHEELS WITH ANTI-LIFT ROLLERS
N	CROWNED NYLON WHEELS WITH SIDE GUIDE ROLLERS
G	RE-GREASABLE BEARINGS ON MAIN WHEELS
S	STAINLESS STEEL HARDWARE
□	OTHER FINISHES AVAILABLE – PLEASE CONTACT US
□	PRE-ASSEMBLY ON SHIPPING FRAME AVAILABLE

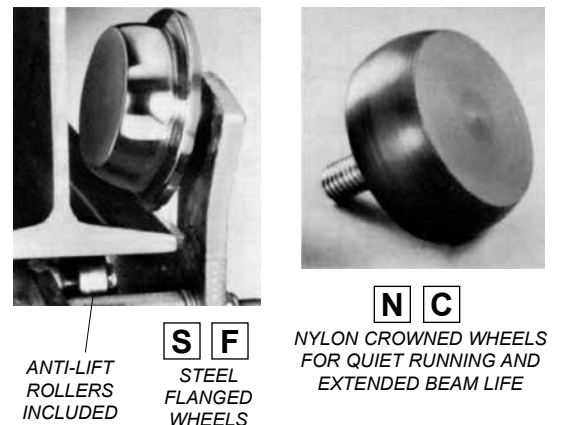

Accessories See detail pages at back of catalog

- CABLE CLAMPS
- SHOCK CORDS
- CABLE, ROUND OR FLAT; HOSE
- TERMINAL BOX(ES)
- TY-RAPS
- CABLE GLANDS FOR SINGLE CABLES OR GROUPS
- TOW ROPES
- TERMINAL BLOCKS

Series I130-D Components & Dimensions

For MIXED Cable or Hose

All dimensions in inches unless otherwise specified.

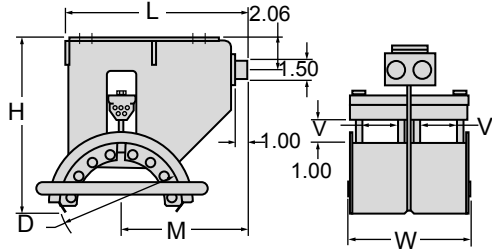
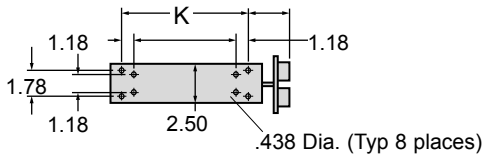

End Clamp *One Required*

Model Number w/ Std Hardware	Saddle Radius R	Saddle Dia. D	Window Height P	Window Width* V	Overall Length L	Overall Width W	Below Beam H	Saddle Locator M	Mtg. Locator J	Bolts K
I130-D10-3307E-Z	5.13	10.25	3.38	7.88	12.75	20.44	13.22	9.31	4.81	6.69
I130-D14-1407E-Z	7.06	14.12	1.44	7.88	15.31	20.44	13.22	10.72	3.44	10.63
I130-D14-1412E-Z	7.06	14.12	1.44	12.69	15.31	30.06	13.22	10.72	3.44	10.63
I130-D18-1807E-Z	9.06	18.12	1.81	7.88	18.63	20.44	16.09	13.47	3.19	14.19
I130-D18-1812E-Z	9.06	18.12	1.81	12.69	18.63	30.06	16.09	13.47	3.19	14.19

Fits all beam sizes. * Window width each side.

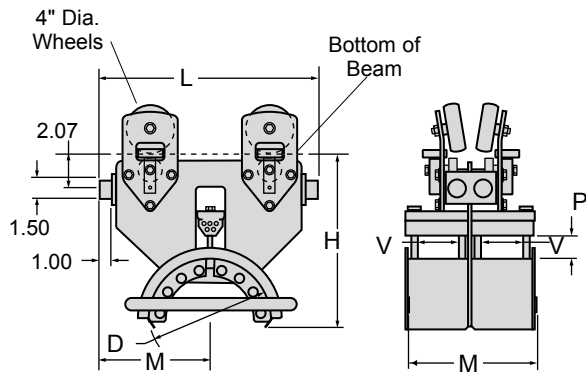

Intermediate Trolley *Quantity as Required*

Model Number w/ Std Hardware & Wheels	Saddle Radius R	Saddle Dia. D	Window Height P	Window Width* V	Overall Length L	Overall Width W	Below Beam H	Saddle Locator M
I130-D10-3307I-Z-SCP-□	5.13	10.25	3.38	7.88	17.88	20.44	13.07	8.94
I130-D14-1407I-Z-SCP-□	7.06	14.12	1.44	7.88	17.88	20.44	13.07	8.94
I130-D14-1412I-Z-SCP-□	7.06	14.12	1.44	12.69	17.88	30.06	13.07	8.94
I130-D18-1807I-Z-SCP-□	9.06	18.12	1.81	7.88	22.59	20.44	15.94	11.29
I130-D18-1812I-Z-SCP-□	9.06	18.12	1.81	12.69	22.59	30.06	15.94	11.29

Your beam size must be added to complete model number. See previous pages.

* Window width each side.

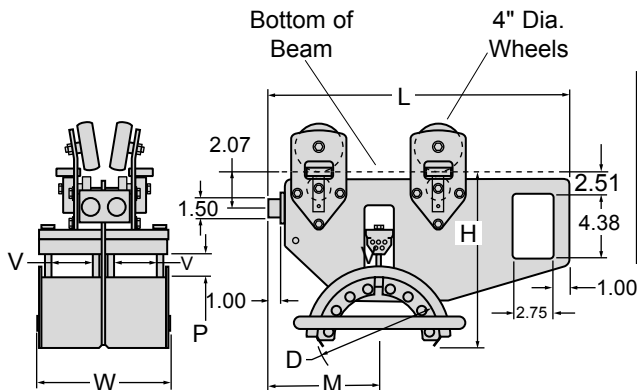

Tow Trolley *Standard...One Required*

Model Number w/ Std Hardware & Wheels	Saddle Radius R	Saddle Dia. D	Window Height P	Window Width* V	Overall Length L	Overall Width W	Below Beam H	Saddle Locator M
I130-D10-3307T-Z-SCP-□	5.13	10.25	3.38	7.88	20.19	20.44	13.07	8.94
I130-D14-1407T-Z-SCP-□	7.06	14.12	1.44	7.88	22.19	20.44	13.07	10.31
I130-D14-1412T-Z-SCP-□	7.06	14.12	1.44	12.69	22.19	30.06	13.07	10.31
I130-D18-1807T-Z-SCP-□	9.06	18.12	1.81	7.88	25.50	20.44	15.94	13.09
I130-D18-1812T-Z-SCP-□	9.06	18.12	1.81	12.69	25.50	30.06	15.94	13.09

Your beam size must be added to complete model number. See previous pages.

* Window width each side of frame plate.

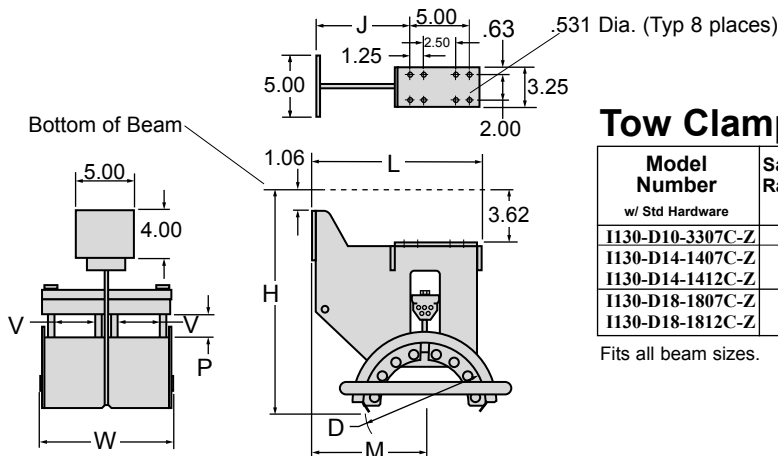

Tow Clamp *Optional...Replaces Tow Trolley (one required)*

Model Number w/ Std Hardware	Saddle Radius R	Saddle Dia. D	Window Height P	Window Width* V	Overall Length L	Overall Width W	Below Beam H	Saddle Locator M	Mtg. Locator J
I130-D10-3307C-Z	5.13	10.25	3.38	7.88	11.91	20.44	16.44	8.44	5.94
I130-D14-1407C-Z	7.06	14.12	1.44	7.88	14.50	20.44	16.62	9.94	7.44
I130-D14-1412C-Z	7.06	14.12	1.44	12.69	14.50	30.06	16.62	9.94	7.44
I130-D18-1807C-Z	9.06	18.12	1.81	7.88	17.84	20.44	19.50	12.69	10.19
I130-D18-1812C-Z	9.06	18.12	1.81	12.69	17.84	30.06	19.50	12.69	10.19

Fits all beam sizes. * Window width each side of frame plate.

New State-of-the-Art Design

Heavy Duty Series I-152 and I-162

- All the **FEATURES** required for years of high speed service, even under the most rugged conditions.
- All the **OPTIONS** needed to precisely fit your specific application.

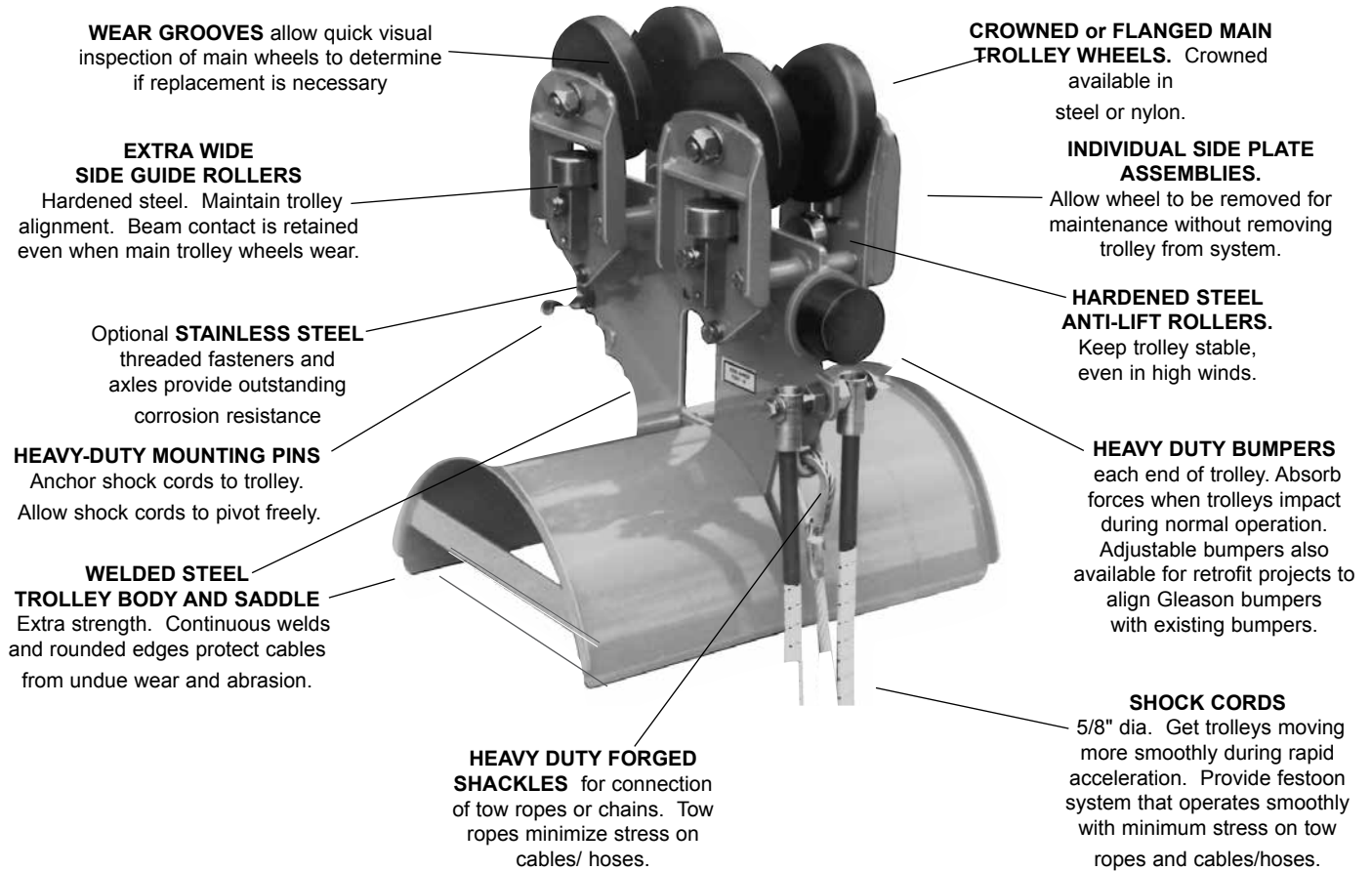

Choice of Cable Clamps or Clips

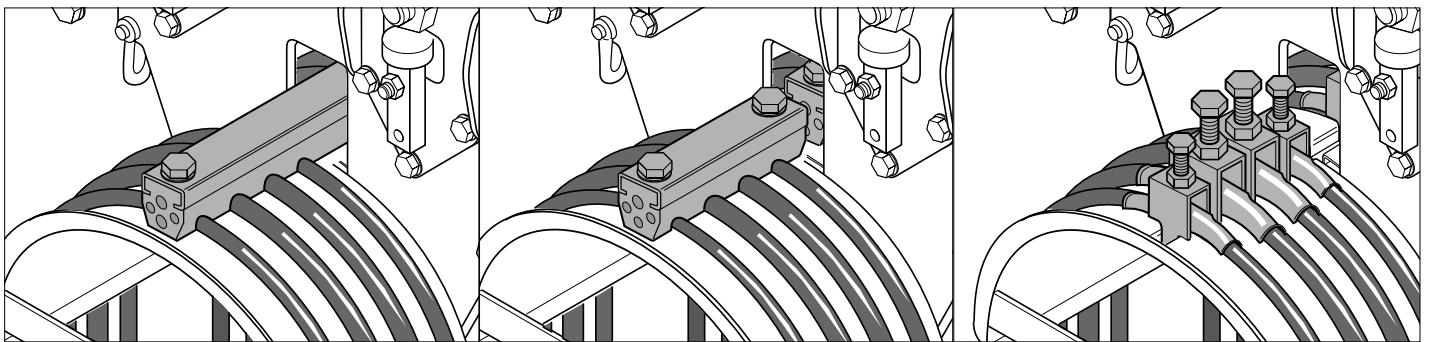

SINGLE CLAMP (left) or DUAL CLAMPS (center)
Single clamp standard on 11.5" & 15" wide saddles.
Dual clamps standard on 20"-30" wide saddles.

INDIVIDUAL CLIPS FOR EACH CABLE/ HOSE
Available as option on all saddle widths.

GLEASON Beam·Master™ SERIES I152

Single or Dual Clamp, Clips

- FLAT, ROUND OR MIXED CABLE/HOSE
- CROWNED 3.94" DIA. STEEL WHEELS STANDARD
- ANTI-LIFT ROLLERS STANDARD
- SEALED BALL BEARINGS STANDARD

- MAX SADDLE DIAMETER = 18.12"
- MAX TROLLEY LOAD = 900 lbs.
- TRAVEL SPEEDS TO 650 fpm
- ACCELERATION—Consult us if over 2.0 ft/sec².
- TRAVEL LENGTHS UNLIMITED

Standard Trolley Design

- Crowned 3.94" steel wheels with side guide rollers.
- Anti-lift rollers
- Sealed bearings are pre-lubricated for life
- Tow trolley included as standard
- Zinc plated hardware
- Orange baked polyester powder finish
- Heavy duty bumpers
- Typical mounting on S6 or larger beams— contact us for special situations
- Cable clamp allows cable pkg height to vary up to 0.63"

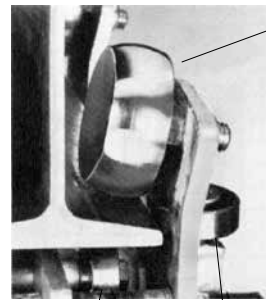

ANTI-LIFT ROLLERS INCLUDED

SIDE-GUIDE ROLLERS INCLUDED

S C

STEEL CROWNED WHEELS



ALL ROLLERS (ANTI-LIFT & SIDE-GUIDE) ARE SEALED AND USE PRECISION BALL BEARINGS

Model Number Explained

For STANDARD DESIGN, specific model numbers are on the following page.

Standard Intermediate Trolley*							Standard	Std. Wheels***	Your Beam										
TYPE	CLAMP STYLE	SADDLE DIAMETER	WINDOW HEIGHT	WINDOW WIDTH	ITEM	FINISH	WHEEL MAT'L	WHEEL STYLE	WHEEL LUBE										
#I152	D	10	-	33	07	I	Z	S	C	P	-				x				
Chosen by computer						Options you select													
* Example above is for INTERMEDIATE TROLLEY (I) Use same option changes (at right) for other components as required							Options		Wheel Options			Minimum Beam Height = 6.0"							
							S	G											
							STAIN-LESS	GALVA-NIZED	N	F	G								
									NYLON	FLANGED	REGREASE								

Optional Design Features

CODE	OPTION
F	FLANGED (STEEL ONLY) WHEELS WITH ANTI-LIFT ROLLERS
N	CROWNED NYLON WHEELS WITH SIDE GUIDE ROLLERS
G	RE-GREASABLE BEARINGS ON MAIN WHEELS
S	STAINLESS STEEL HARDWARE
	OTHER FINISHES AVAILABLE – PLEASE CONTACT US
	PRE-ASSEMBLY ON SHIPPING FRAME AVAILABLE

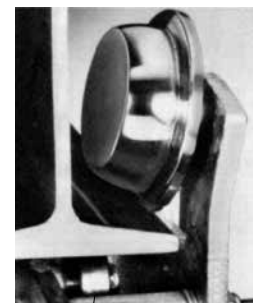

ANTI-LIFT ROLLERS INCLUDED



N C

NYLON CROWNED WHEELS FOR QUIET RUNNING AND EXTENDED BEAM LIFE

S F
STEEL FLANGED WHEELS

Accessories See detail pages at back of catalog

- CABLE CLAMPS
- SHOCK CORDS
- CABLE, ROUND OR FLAT; HOSE
- TERMINAL BOX(ES)
- TY-RAPS
- CABLE GLANDS FOR SINGLE CABLES OR GROUPS
- TOW ROPES
- TERMINAL BLOCKS

Series I152 Components & Dimensions

SINGLE & DUAL Clamp Design—Contact us for multiple tier requirements. Also available with cable/hose clips.

All dimensions in inches unless otherwise specified.

End Clamp *One Required*

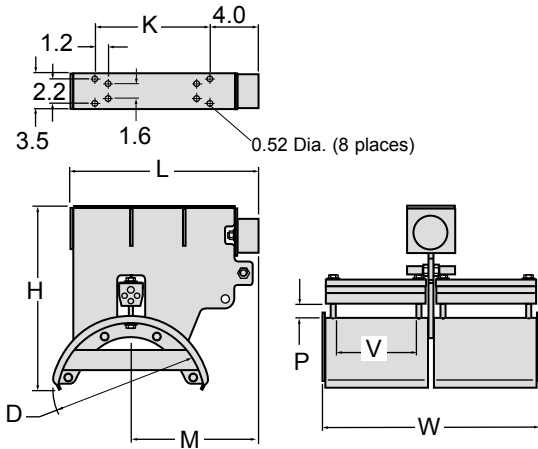

Model Number w/ Std Hardware & Wheels	Saddle Dia. D	Window Height P	Window Width* V	Overall Length L	Overall Width W	Below Beam H	Saddle Locator M	Bolt K
I152-S10-1004E-ZP	10.25	1.06	4.38	12.32	11.51	15.10	8.52	7.07
I152-S10-1006E-ZP	10.25	1.06	6.19	12.32	15.13	15.10	8.52	7.07
I152-D10-1007E-ZP	10.25	1.06	7.88	12.32	20.51	15.10	8.52	7.07
I152-D10-1010E-ZP	10.25	1.06	10.17	12.32	25.06	15.10	8.52	7.07
I152-D10-1012E-ZP	10.25	1.06	12.69	12.32	30.20	15.10	8.52	7.07
I152-S10-3304E-ZP	10.25	3.30	4.38	15.50	11.51	15.10	10.51	10.25
I152-S10-3306E-ZP	10.25	3.30	6.19	15.50	15.13	15.10	10.51	10.25
I152-D10-3307E-ZP	10.25	3.30	7.88	15.50	20.51	15.10	10.51	10.25
I152-D10-3310E-ZP	10.25	3.30	10.17	15.50	25.06	15.10	10.51	10.25
I152-D10-3312E-ZP	10.25	3.30	12.69	15.50	30.20	15.10	10.51	10.25
I152-S14-1404E-ZP	14.12	1.44	4.38	15.50	11.51	16.60	10.51	10.25
I152-S14-1406E-ZP	14.12	1.44	6.19	15.50	15.13	16.60	10.51	10.25
I152-D14-1407E-ZP	14.12	1.44	7.88	15.50	20.51	16.60	10.51	10.25
I152-D14-1410E-ZP	14.12	1.44	10.17	15.50	25.06	16.60	10.51	10.25
I152-D14-1412E-ZP	14.12	1.44	12.69	15.50	30.20	16.60	10.51	10.25
I152-S18-1804E-ZP	18.12	1.81	4.38	19.00	11.51	18.10	12.65	13.76
I152-S18-1806E-ZP	18.12	1.81	6.19	19.00	15.13	18.10	12.65	13.76
I152-D18-1807E-ZP	18.12	1.81	7.88	19.00	20.51	18.10	12.65	13.76
I152-D18-1810E-ZP	18.12	1.81	10.17	19.00	25.06	18.10	12.65	13.76
I152-D18-1812E-ZP	18.12	1.81	12.69	19.00	30.20	18.10	12.65	13.76

Fits all beam sizes.

* Window width each side of frame plate on single clamp models (designated by “S” in model number) or distance between clamp bolts on double clamp models (“D” in number). Window height and width do not apply to clip models. Clips available on all saddle widths. Consult factory for quantity and size of clips for your application. To order clips, replace “S” or “D” in model number with “C”.

Intermediate Trolley *Quantity as Required*

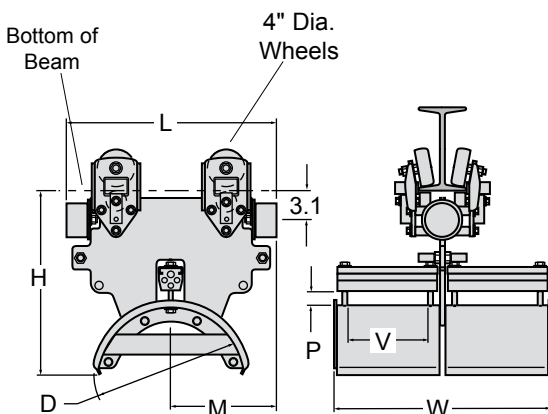

Model Number w/ Std Hardware & Wheels	Saddle Dia. D	Window Height P	Window Width* V	Overall Length L	Overall Width W	Below Beam H	Saddle Locator M
I152-S10-1004I-ZP-SCP-□	10.25	1.06	4.38	15.36	11.51	15.10	7.68
I152-S10-1006I-ZP-SCP-□	10.25	1.06	6.19	15.36	15.13	15.10	7.68
I152-D10-1007I-ZP-SCP-□	10.25	1.06	7.88	15.36	20.51	15.10	7.68
I152-D10-1010I-ZP-SCP-□	10.25	1.06	10.17	15.36	25.06	15.10	7.68
I152-D10-1012I-ZP-SCP-□	10.25	1.06	12.69	15.36	30.20	15.10	7.68
I152-S10-3304I-ZP-SCP-□	10.25	3.30	4.38	18.62	11.51	15.10	9.31
I152-S10-3306I-ZP-SCP-□	10.25	3.30	6.19	18.62	15.13	15.10	9.31
I152-D10-3307I-ZP-SCP-□	10.25	3.30	7.88	18.62	20.51	15.10	9.31
I152-D10-3310I-ZP-SCP-□	10.25	3.30	10.17	18.62	25.06	15.10	9.31
I152-D10-3312I-ZP-SCP-□	10.25	3.30	12.69	18.62	30.20	15.10	9.31
I152-S14-1404I-ZP-SCP-□	14.12	1.44	4.38	18.62	11.51	16.60	9.31
I152-S14-1406I-ZP-SCP-□	14.12	1.44	6.19	18.62	15.13	16.60	9.31
I152-D14-1407I-ZP-SCP-□	14.12	1.44	7.88	18.62	20.51	16.60	9.31
I152-D14-1410I-ZP-SCP-□	14.12	1.44	10.17	18.62	25.06	16.60	9.31
I152-D14-1412I-ZP-SCP-□	14.12	1.44	12.69	18.62	30.20	16.60	9.31
I152-S18-1804I-ZP-SCP-□	18.12	1.81	4.38	22.94	11.51	18.10	11.47
I152-S18-1806I-ZP-SCP-□	18.12	1.81	6.19	22.94	15.13	18.10	11.47
I152-D18-1807I-ZP-SCP-□	18.12	1.81	7.88	22.94	20.51	18.10	11.47
I152-D18-1810I-ZP-SCP-□	18.12	1.81	10.17	22.94	25.06	18.10	11.47
I152-D18-1812I-ZP-SCP-□	18.12	1.81	12.69	22.94	30.20	18.10	11.47

Your beam size must be added to complete model number. See previous pages.

* Window width each side of frame plate on single clamp models (designated by “S” in model number) or distance between clamp bolts on double clamp models (“D” in number). Window height and width do not apply to clip models. Clips available on all saddle widths. Consult factory for quantity and size of clips for your application. To order clips, replace “S” or “D” in model number with “C”.

Series I152 Components & Dimensions, con't.

SINGLE & DUAL Clamp Design—Contact us for multiple tier requirements. Also available with cable/hose clips.

All dimensions in inches unless otherwise specified.

Tow Trolley *Standard...One Required*

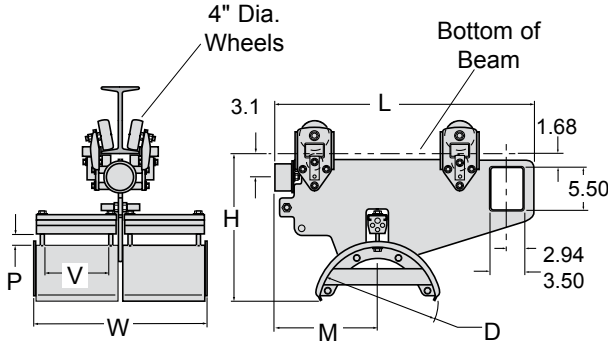

Model Number	Saddle Dia. D	Window Height P	Window Width* V	Overall Length L	Overall Width W	Below Beam H	Saddle Locator M
<i>w/ Std Hardware & Wheels</i>							
I152-S10-1004T-ZP-SCP-□	10.25	1.06	4.38	18.66	11.51	15.10	7.76
I152-S10-1006T-ZP-SCP-□	10.25	1.06	6.19	18.66	15.13	15.10	7.76
I152-D10-1007T-ZP-SCP-□	10.25	1.06	7.88	18.66	20.51	15.10	7.76
I152-D10-1010T-ZP-SCP-□	10.25	1.06	10.17	18.66	25.06	15.10	7.76
I152-D10-1012T-ZP-SCP-□	10.25	1.06	12.69	18.66	30.20	15.10	7.76
I152-S10-3304T-ZP-SCP-□	10.25	3.30	4.38	25.31	11.51	15.10	11.00
I152-S10-3306T-ZP-SCP-□	10.25	3.30	6.19	25.31	15.13	15.10	11.00
I152-D10-3307T-ZP-SCP-□	10.25	3.30	7.88	25.31	20.51	15.10	11.00
I152-D10-3310T-ZP-SCP-□	10.25	3.30	10.17	25.31	25.06	15.10	11.00
I152-D10-3312T-ZP-SCP-□	10.25	3.30	12.69	25.31	30.20	15.10	11.00
I152-S14-1404T-ZP-SCP-□	14.12	1.44	4.38	25.31	11.51	16.60	11.00
I152-S14-1406T-ZP-SCP-□	14.12	1.44	6.19	25.31	15.13	16.60	11.00
I152-D14-1407T-ZP-SCP-□	14.12	1.44	7.88	25.31	20.51	16.60	11.00
I152-D14-1410T-ZP-SCP-□	14.12	1.44	10.17	25.31	25.06	16.60	11.00
I152-D14-1412T-ZP-SCP-□	14.12	1.44	12.69	25.31	30.20	16.60	11.00
I152-S18-1804T-ZP-SCP-□	18.12	1.81	4.38	30.82	11.51	18.10	13.75
I152-S18-1806T-ZP-SCP-□	18.12	1.81	6.19	30.82	15.13	18.10	13.75
I152-D18-1807T-ZP-SCP-□	18.12	1.81	7.88	30.82	20.51	18.10	13.75
I152-D18-1810T-ZP-SCP-□	18.12	1.81	10.17	30.82	25.06	18.10	13.75
I152-D18-1812T-ZP-SCP-□	18.12	1.81	12.69	30.82	30.20	18.10	13.75

Your beam size must be added to complete model number. See previous pages.

* Window width each side of frame plate on single clamp models (designated by "S" in model number) or distance between clamp bolts on double clamp models ("D" in number). Window height and width do not apply to clip models. Clips available on all saddle widths. Consult factory for quantity and size of clips for your application. To order clips, replace "S" or "D" in model number with "C".

Tow Clamp *Optional...Replaces Tow Trolley (one required)*

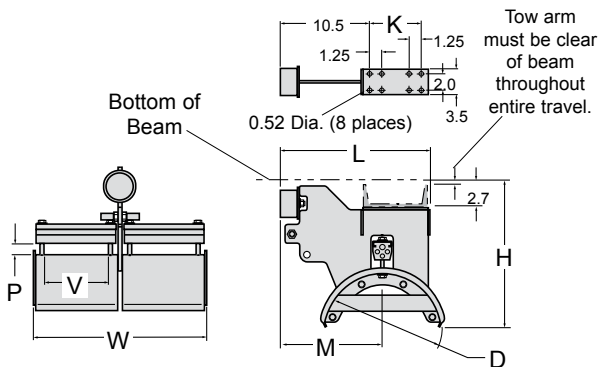

Model Number	Saddle Dia. D	Window Height P	Window Width* V	Overall Length L	Overall Width W	Below Beam H	Saddle Locator M	Bolt K
<i>w/ Std Hardware & Wheels</i>								
I152-S10-1004C-ZP	10.25	1.06	4.38	15.50	11.51	15.10	12.03	5.00
I152-S10-1006C-ZP	10.25	1.06	6.19	15.50	15.13	15.10	12.03	5.00
I152-D10-1007C-ZP	10.25	1.06	7.88	15.50	20.51	15.10	12.03	5.00
I152-D10-1010C-ZP	10.25	1.06	10.17	15.50	25.06	15.10	12.03	5.00
I152-D10-1012C-ZP	10.25	1.06	12.69	15.50	30.20	15.10	12.03	5.00
I152-S10-3304C-ZP	10.25	3.30	4.38	15.50	11.51	15.10	12.03	5.00
I152-S10-3306C-ZP	10.25	3.30	6.19	15.50	15.13	15.10	12.03	5.00
I152-D10-3307C-ZP	10.25	3.30	7.88	15.50	20.51	15.10	12.03	5.00
I152-D10-3310C-ZP	10.25	3.30	10.17	15.50	25.06	15.10	12.03	5.00
I152-D10-3312C-ZP	10.25	3.30	12.69	15.50	30.20	15.10	12.03	5.00
I152-S14-1404C-ZP	14.12	1.44	4.38	15.50	11.51	16.60	12.03	5.00
I152-S14-1406C-ZP	14.12	1.44	6.19	15.50	15.13	16.60	12.03	5.00
I152-D14-1407C-ZP	14.12	1.44	7.88	15.50	20.51	16.60	12.03	5.00
I152-D14-1410C-ZP	14.12	1.44	10.17	15.50	25.06	16.60	12.03	5.00
I152-D14-1412C-ZP	14.12	1.44	12.69	15.50	30.20	16.60	12.03	5.00
I152-S18-1804C-ZP	18.12	1.81	4.38	19.00	11.51	18.10	19.00	7.00
I152-S18-1806C-ZP	18.12	1.81	6.19	19.00	15.13	18.10	19.00	7.00
I152-D18-1807C-ZP	18.12	1.81	7.88	19.00	20.51	18.10	19.00	7.00
I152-D18-1810C-ZP	18.12	1.81	10.17	19.00	25.06	18.10	19.00	7.00
I152-D18-1812C-ZP	18.12	1.81	12.69	19.00	30.20	18.10	19.00	7.00

Fits all beam sizes.

* Window width each side of frame plate on single clamp models (designated by "S" in model number) or distance between clamp bolts on double clamp models ("D" in number). Window height and width do not apply to clip models. Clips available on all saddle widths. Consult factory for quantity and size of clips for your application. To order clips, replace "S" or "D" in model number with "C".

GLEASON Beam·Master™ SERIES I162

Single or Dual Clamp, Clips

- FLAT, ROUND OR MIXED CABLE/HOSE
- CROWNED 6" DIA. STEEL WHEELS STANDARD
- ANTI-LIFT ROLLERS STANDARD
- SEALED BALL BEARINGS STANDARD

- MAX SADDLE DIAMETER = 18.12"
- MAX TROLLEY LOAD = 1100 lbs.
- TRAVEL SPEEDS TO 800 fpm
- ACCELERATION—Consult us if over 2.0 ft/sec².
- TRAVEL LENGTHS UNLIMITED

Standard Trolley Design

- Crowned 6" steel wheels with side guide rollers.
- Anti-lift rollers
- Sealed bearings are pre-lubricated for life
- Tow trolley included as standard
- Zinc plated hardware
- Orange baked polyester powder finish
- Heavy duty bumpers
- Typical mounting on S6 or larger beams (S5 or larger with optional flanged wheels)— contact us for special situations
- Cable clamp allows cable pkg height to vary up to 0.63"

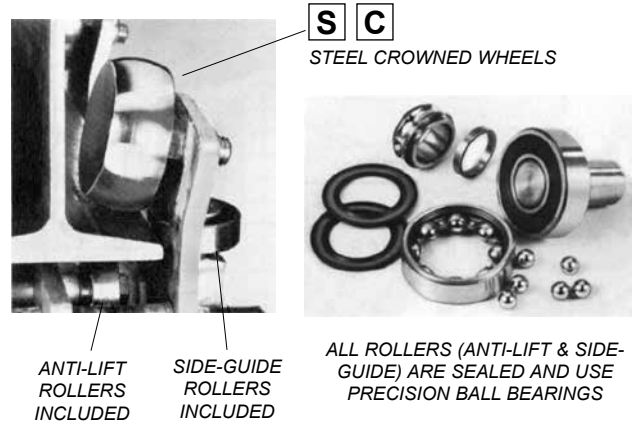

Model Number Explained

For STANDARD DESIGN, specific model numbers are on the following page.

Standard Intermediate Trolley*							Standard	Std. Wheels***	Your Beam		
TYPE	CLAMP STYLE	SADDLE DIAMETER	WINDOW HEIGHT	WINDOW WIDTH	ITEM	FINISH	WHEEL MAT'L	WHEEL STYLE	WHEEL LUBE		
#I162	D**	10	- 33	07	I	Z	S	C	P-	□ □ □ x □ □ □ . □	
Chosen by computer						Options you select					
* Example above is for INTERMEDIATE TROLLEY (I) Use same option changes (at right) for other components as required						Options	Wheel Options			Minimum Beam Height = 8.0"	
						S STAIN-LESS	G GALVA-NIZED	N NYLON	F FLANGED	G REGREASE	

Optional Design Features

CODE	OPTION
F	FLANGED (STEEL ONLY) WHEELS WITH ANTI-LIFT ROLLERS
N	CROWNED NYLON WHEELS WITH SIDE GUIDE ROLLERS
G	RE-GREASABLE BEARINGS ON MAIN WHEELS
S	STAINLESS STEEL HARDWARE
□	OTHER FINISHES AVAILABLE – PLEASE CONTACT US
□	PRE-ASSEMBLY ON SHIPPING FRAME AVAILABLE

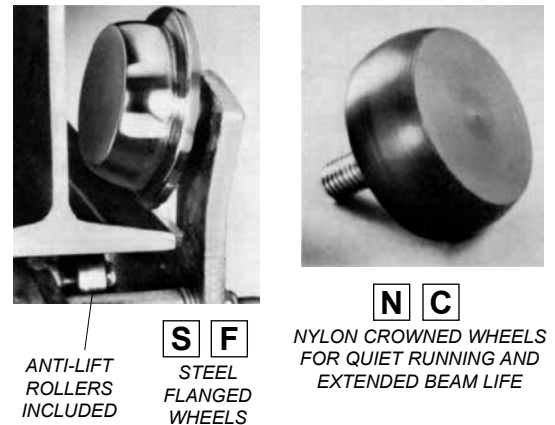

Accessories

See detail pages at back of catalog

- CABLE CLAMPS
- SHOCK CORDS
- CABLE, ROUND OR FLAT; HOSE
- TERMINAL BOX(ES)
- TY-RAPS
- CABLE GLANDS FOR SINGLE CABLES OR GROUPS
- TOW ROPES
- TERMINAL BLOCKS

Series I162 Components & Dimensions

SINGLE & DUAL Clamp Design—Contact us for multiple tier requirements. Also available with cable/hose clips.

All dimensions in inches unless otherwise specified.

End Clamp *One Required*

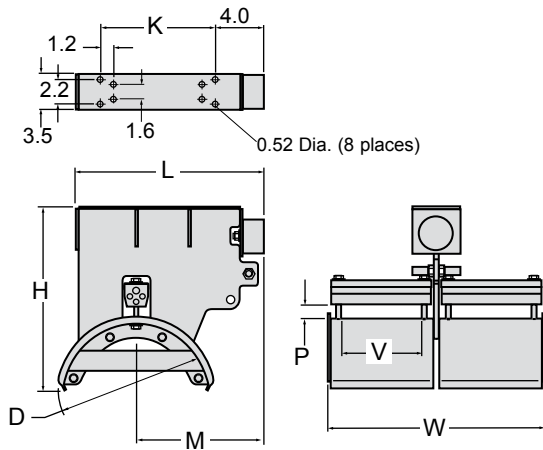

Model Number w/ Std Hardware & Wheels	Saddle Dia. D	Window Height P	Window Width* V	Overall Length L	Overall Width W	Below Beam H	Saddle Locator M	Bolt K
I162-S10-1004E-ZP	10.25	1.06	4.38	12.32	11.51	15.10	8.52	7.07
I162-S10-1006E-ZP	10.25	1.06	6.19	12.32	15.13	15.10	8.52	7.07
I162-D10-1007E-ZP	10.25	1.06	7.88	12.32	20.51	15.10	8.52	7.07
I162-D10-1010E-ZP	10.25	1.06	10.17	12.32	25.06	15.10	8.52	7.07
I162-D10-1012E-ZP	10.25	1.06	12.69	12.32	30.20	15.10	8.52	7.07
I162-S10-3304E-ZP	10.25	3.30	4.38	15.50	11.51	15.10	10.51	10.25
I162-S10-3306E-ZP	10.25	3.30	6.19	15.50	15.13	15.10	10.51	10.25
I162-D10-3307E-ZP	10.25	3.30	7.88	15.50	20.51	15.10	10.51	10.25
I162-D10-3310E-ZP	10.25	3.30	10.17	15.50	25.06	15.10	10.51	10.25
I162-D10-3312E-ZP	10.25	3.30	12.69	15.50	30.20	15.10	10.51	10.25
I162-S14-1404E-ZP	14.12	1.44	4.38	15.50	11.51	16.60	10.51	10.25
I162-S14-1406E-ZP	14.12	1.44	6.19	15.50	15.13	16.60	10.51	10.25
I162-D14-1407E-ZP	14.12	1.44	7.88	15.50	20.51	16.60	10.51	10.25
I162-D14-1410E-ZP	14.12	1.44	10.17	15.50	25.06	16.60	10.51	10.25
I162-D14-1412E-ZP	14.12	1.44	12.69	15.50	30.20	16.60	10.51	10.25
I162-S18-1804E-ZP	18.12	1.81	4.38	19.00	11.51	18.10	12.65	13.76
I162-S18-1806E-ZP	18.12	1.81	6.19	19.00	15.13	18.10	12.65	13.76
I162-D18-1807E-ZP	18.12	1.81	7.88	19.00	20.51	18.10	12.65	13.76
I162-D18-1810E-ZP	18.12	1.81	10.17	19.00	25.06	18.10	12.65	13.76
I162-D18-1812E-ZP	18.12	1.81	12.69	19.00	30.20	18.10	12.65	13.76

Fits all beam sizes.

* Window width each side of frame plate on single clamp models (designated by "S" in model number) or distance between clamp bolts on double clamp models ("D" in number). Window height and width do not apply to clip models. Clips available on all saddle widths. Consult factory for quantity and size of clips for your application. To order clips, replace "S" or "D" in model number with "C".

Intermediate Saddle Trolley *Quantity as Required*

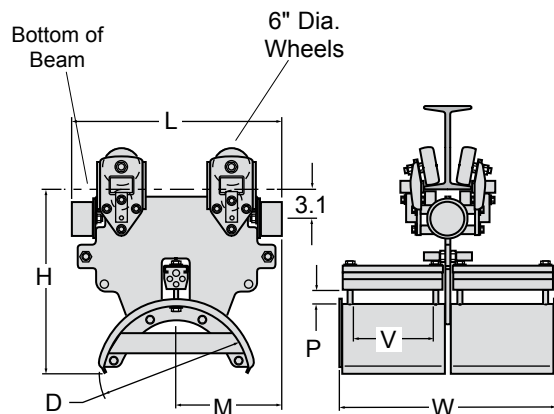

Model Number w/ Std Hardware & Wheels	Saddle Dia. D	Window Height P	Window Width* V	Overall Length L	Overall Width W	Below Beam H	Saddle Locator M
I162-S10-1004I-ZP-SCP-□	10.25	1.06	4.38	15.36	11.51	15.10	7.68
I162-S10-1006I-ZP-SCP-□	10.25	1.06	6.19	15.36	15.13	15.10	7.68
I162-D10-1007I-ZP-SCP-□	10.25	1.06	7.88	15.36	20.51	15.10	7.68
I162-D10-1010I-ZP-SCP-□	10.25	1.06	10.17	15.36	25.06	15.10	7.68
I162-D10-1012I-ZP-SCP-□	10.25	1.06	12.69	15.36	30.20	15.10	7.68
I162-S10-3304I-ZP-SCP-□	10.25	3.30	4.38	18.62	11.51	15.10	9.31
I162-S10-3306I-ZP-SCP-□	10.25	3.30	6.19	18.62	15.13	15.10	9.31
I162-D10-3307I-ZP-SCP-□	10.25	3.30	7.88	18.62	20.51	15.10	9.31
I162-D10-3310I-ZP-SCP-□	10.25	3.30	10.17	18.62	25.06	15.10	9.31
I162-D10-3312I-ZP-SCP-□	10.25	3.30	12.69	18.62	30.20	15.10	9.31
I162-S14-1404I-ZP-SCP-□	14.12	1.44	4.38	18.62	11.51	16.60	9.31
I162-S14-1406I-ZP-SCP-□	14.12	1.44	6.19	18.62	15.13	16.60	9.31
I162-D14-1407I-ZP-SCP-□	14.12	1.44	7.88	18.62	20.51	16.60	9.31
I162-D14-1410I-ZP-SCP-□	14.12	1.44	10.17	18.62	25.06	16.60	9.31
I162-D14-1412I-ZP-SCP-□	14.12	1.44	12.69	18.62	30.20	16.60	9.31
I162-S18-1804I-ZP-SCP-□	18.12	1.81	4.38	22.94	11.51	18.10	11.47
I162-S18-1806I-ZP-SCP-□	18.12	1.81	6.19	22.94	15.13	18.10	11.47
I162-D18-1807I-ZP-SCP-□	18.12	1.81	7.88	22.94	20.51	18.10	11.47
I162-D18-1810I-ZP-SCP-□	18.12	1.81	10.17	22.94	25.06	18.10	11.47
I162-D18-1812I-ZP-SCP-□	18.12	1.81	12.69	22.94	30.20	18.10	11.47

Your beam size must be added to complete model number. See previous pages.

* Window width each side of frame plate on single clamp models (designated by "S" in model number) or distance between clamp bolts on double clamp models ("D" in number). Window height and width do not apply to clip models. Clips available on all saddle widths. Consult factory for quantity and size of clips for your application. To order clips, replace "S" or "D" in model number with "C".

Series I162 Components & Dimensions, con't.

SINGLE & DUAL Clamp Design—Contact us for multiple tier requirements. Also available with cable/hose clips.

All dimensions in inches unless otherwise specified.

Tow Trolley *Standard...One Required*

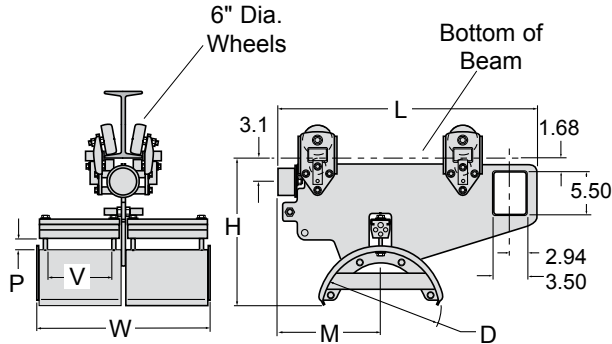

Model Number w/ Std Hardware & Wheels	Saddle Dia. D	Window Height P	Window Width* V	Overall Length L	Overall Width W	Below Beam H	Saddle Locator M
I162-S10-1004T-ZP-SCP-□	10.25	1.06	4.38	18.66	11.51	15.10	7.76
I162-S10-1006T-ZP-SCP-□	10.25	1.06	6.19	18.66	15.13	15.10	7.76
I162-D10-1007T-ZP-SCP-□	10.25	1.06	7.88	18.66	20.51	15.10	7.76
I162-D10-1010T-ZP-SCP-□	10.25	1.06	10.17	18.66	25.06	15.10	7.76
I162-D10-1012T-ZP-SCP-□	10.25	1.06	12.69	18.66	30.20	15.10	7.76
I162-S10-3304T-ZP-SCP-□	10.25	3.30	4.38	25.31	11.51	15.10	11.00
I162-S10-3306T-ZP-SCP-□	10.25	3.30	6.19	25.31	15.13	15.10	11.00
I162-D10-3307T-ZP-SCP-□	10.25	3.30	7.88	25.31	20.51	15.10	11.00
I162-D10-3310T-ZP-SCP-□	10.25	3.30	10.17	25.31	25.06	15.10	11.00
I162-D10-3312T-ZP-SCP-□	10.25	3.30	12.69	25.31	30.20	15.10	11.00
I162-S14-1404T-ZP-SCP-□	14.12	1.44	4.38	25.31	11.51	16.60	11.00
I162-S14-1406T-ZP-SCP-□	14.12	1.44	6.19	25.31	15.13	16.60	11.00
I162-D14-1407T-ZP-SCP-□	14.12	1.44	7.88	25.31	20.51	16.60	11.00
I162-D14-1410T-ZP-SCP-□	14.12	1.44	10.17	25.31	25.06	16.60	11.00
I162-D14-1412T-ZP-SCP-□	14.12	1.44	12.69	25.31	30.20	16.60	11.00
I162-S18-1804T-ZP-SCP-□	18.12	1.81	4.38	30.82	11.51	18.10	13.75
I162-S18-1806T-ZP-SCP-□	18.12	1.81	6.19	30.82	15.13	18.10	13.75
I162-D18-1807T-ZP-SCP-□	18.12	1.81	7.88	30.82	20.51	18.10	13.75
I162-D18-1810T-ZP-SCP-□	18.12	1.81	10.17	30.82	25.06	18.10	13.75
I162-D18-1812T-ZP-SCP-□	18.12	1.81	12.69	30.82	30.20	18.10	13.75

Your beam size must be added to complete model number. See previous pages.

* Window width each side of frame plate on single clamp models (designated by "S" in model number) or distance between clamp bolts on double clamp models ("D" in number). Window height and width do not apply to clip models. Clips available on all saddle widths. Consult factory for quantity and size of clips for your application. To order clips, replace "S" or "D" in model number with "C".

Tow Clamp *Optional...Replaces Tow Trolley (one required)*

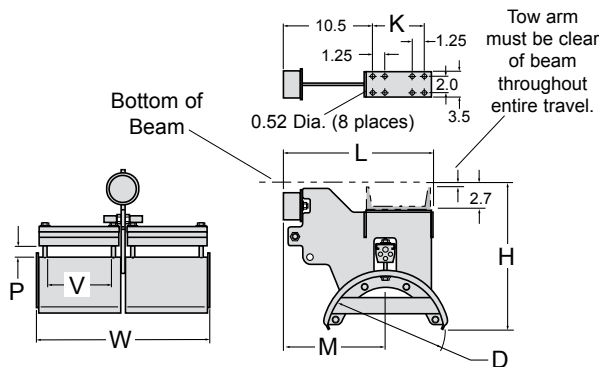

Model Number w/ Std Hardware & Wheels	Saddle Dia. D	Window Height P	Window Width* V	Overall Length L	Overall Width W	Below Beam H	Saddle Locator M	Bolt K
I162-S10-1004C-ZP	10.25	1.06	4.38	15.50	11.51	15.10	12.03	5.00
I162-S10-1006C-ZP	10.25	1.06	6.19	15.50	15.13	15.10	12.03	5.00
I162-D10-1007C-ZP	10.25	1.06	7.88	15.50	20.51	15.10	12.03	5.00
I162-D10-1010C-ZP	10.25	1.06	10.17	15.50	25.06	15.10	12.03	5.00
I162-D10-1012C-ZP	10.25	1.06	12.69	15.50	30.20	15.10	12.03	5.00
I162-S10-3304C-ZP	10.25	3.30	4.38	15.50	11.51	15.10	12.03	5.00
I162-S10-3306C-ZP	10.25	3.30	6.19	15.50	15.13	15.10	12.03	5.00
I162-D10-3307C-ZP	10.25	3.30	7.88	15.50	20.51	15.10	12.03	5.00
I162-D10-3310C-ZP	10.25	3.30	10.17	15.50	25.06	15.10	12.03	5.00
I162-D10-3312C-ZP	10.25	3.30	12.69	15.50	30.20	15.10	12.03	5.00
I162-S14-1404C-ZP	14.12	1.44	4.38	15.50	11.51	16.60	12.03	5.00
I162-S14-1406C-ZP	14.12	1.44	6.19	15.50	15.13	16.60	12.03	5.00
I162-D14-1407C-ZP	14.12	1.44	7.88	15.50	20.51	16.60	12.03	5.00
I162-D14-1410C-ZP	14.12	1.44	10.17	15.50	25.06	16.60	12.03	5.00
I162-D14-1412C-ZP	14.12	1.44	12.69	15.50	30.20	16.60	12.03	5.00
I162-S18-1804C-ZP	18.12	1.81	4.38	19.00	11.51	18.10	19.00	7.00
I162-S18-1806C-ZP	18.12	1.81	6.19	19.00	15.13	18.10	19.00	7.00
I162-D18-1807C-ZP	18.12	1.81	7.88	19.00	20.51	18.10	19.00	7.00
I162-D18-1810C-ZP	18.12	1.81	10.17	19.00	25.06	18.10	19.00	7.00
I162-D18-1812C-ZP	18.12	1.81	12.69	19.00	30.20	18.10	19.00	7.00

Fits all beam sizes.

* Window width each side of frame plate on single clamp models (designated by "S" in model number) or distance between clamp bolts on double clamp models ("D" in number). Window height and width do not apply to clip models. Clips available on all saddle widths. Consult factory for quantity and size of clips for your application. To order clips, replace "S" or "D" in model number with "C".

Accessories

NO NEED TO SEARCH FOR THE CORRECT ACCESSORY MODEL!

When the Gleason festoon computer program selects a system, you simply indicate which accessories you desire and the correct model number will be selected for you and identified on the OUTPUT page.

0.301

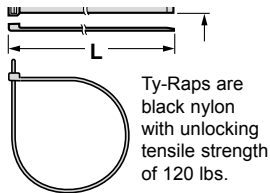

Ty-Raps are black nylon with unlocking tensile strength of 120 lbs.

Ty-Raps

MODEL NUMBER	BUNDLE RANGE	LENGTH L
TY - 08	0.19 - 2.00	8.00
TY - 13	0.19 - 3.50	13.88
TY - 30	1.50 - 9.00	30.00

These pages provide support data.

ALL DIMENSIONS IN INCHES UNLESS OTHERWISE INDICATED.

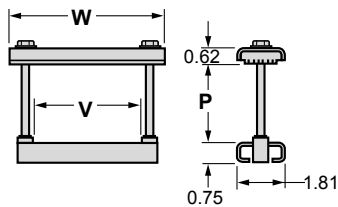

Cable Clamps

FLAT CLAMP DESIGN

SERIES I110 & I115

MODEL NUMBER	WINDOW V	WIDTH W
CL-F01-□-Z	1.88	3.75
CL-F02-□-Z	2.62	4.50
CL-F05-□-Z	5.00	6.88
CL-F06-□-Z	6.56	8.44
CL-F08-□-Z	8.56	10.44

May be supplied with stainless steel hardware. Substitute "S" for "Z" in model numbers above.

PKG HGT CODE □	PKG HGT RANGE P
1	0.00 - 1.27
2	1.28 - 1.77
3	1.78 - 2.27
4	2.28 - 2.77
5	2.78 - 3.27
6	3.28 - 3.77
7	3.78 - 4.27
8	4.28 - 4.77

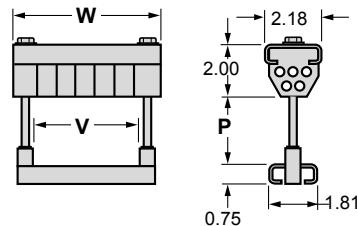

MIXED CLAMP DESIGN

SERIES I120, I130, I152 & I162

MODEL NUMBER	WINDOW V	WIDTH W
CL-M01-□-Z	1.88	3.75
CL-M02-□-Z	2.62	4.50
CL-M05-□-Z	5.00	6.88
CL-M06-□-Z	6.56	8.44
CL-M08-□-Z	8.56	10.44

May be supplied with stainless steel hardware. Substitute "S" for "Z" in model numbers above.

Code is substituted for □ to complete model number.

PKG HGT CODE □	PKG HGT RANGE P
1	0.00 - 0.89
2	0.90 - 1.39
3	1.40 - 1.89
4	1.90 - 2.39
5	2.40 - 2.89

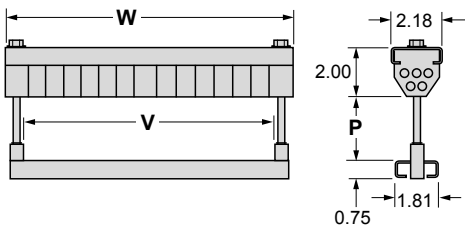

Cable Clamps

SINGLE CLAMP DESIGN

MODEL NUMBER	WINDOW V	WIDTH W
CL-S09-□-Z	9.06	10.94
CL-S12-□-Z	12.69	14.56

May be supplied with stainless steel hardware. Substitute "S" for "Z" in model numbers above.

PKG HGT CODE □	PKG HGT RANGE P
1	0.00 - 0.89
2	0.90 - 1.39
3	1.40 - 1.89
4	1.90 - 2.39
5	2.40 - 2.89
6	2.90 - 3.39

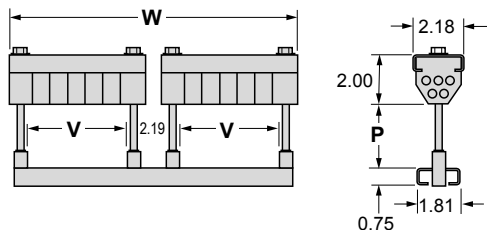

DUAL CLAMP DESIGN

MODEL NUMBER	WINDOW V	WIDTH W
CL-D07-□-Z	7.88	19.81
CL-D12-□-Z	12.69	29.44

May be supplied with stainless steel hardware. Substitute "S" for "Z" in model numbers above.

Code applies to both single and double clamps. Substitute code for □ to complete model number.

Cable Loop Organizer

Controls cables during high speed festoon operation, limiting cable slap and loop swings. Consists of a loop of high strength rubber formed in a concave shape to match the bottom of the cable loops. One organizer is required for each loop in the system.

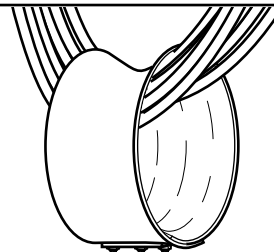

MODEL NUMBER	NOMINAL I.D.
CLO-01	9"
CLO-02	6"

Series I110 Tow Chain

MODEL NUMBER	HARDWARE OPTION
TC - □□.□ - Z	Zinc Plated Steel
TC - □□.□ - S	Stainless Steel

Tow Chains are straight-link No. 2/0 machine chain with zinc plate finish. Standard hardware is zinc plated steel. Load limit is 350 lbs.

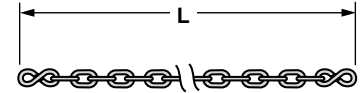

Substitute desired length in FEET for "®.®" to complete Model Number. Round up in half-foot increments.

Series I115, I120, I130, I152, I162 Tow Rope

MODEL NUMBER	HARDWARE OPTION
TR - □□.□ - Z	Zinc Plated Steel
TR - □□.□ - S	Stainless Steel

Tow Ropes are 0.25/0.31 inch vinyl-coated wire rope. Standard hardware is zinc-plated steel. Load limit is 2750 lbs.

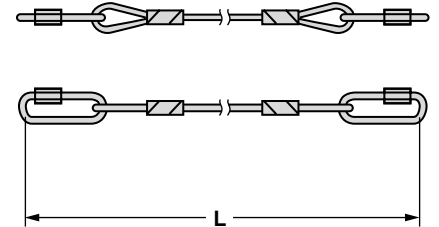

Substitute desired length in FEET for "®.®" to complete Model Number. Round up in half-foot increments.

Series I115, I120, I130, I152, I162 Shock Cord

MODEL NUMBER
SC - □□.□

Shock cords are made of elastomeric material, lengths suited to specific application.

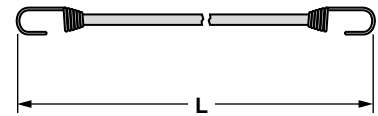

Substitute desired length in FEET for "®.®" to complete Model Number. Round up in half-foot increments.

Junction Box WALL AND RAIL MOUNTED

MODEL NUMBER	RATING
JB - 03 - □ - W	NEMA 3
JB - 04 - □ - W	NEMA 4
JB - 4X - □ - W	NEMA 4X
JB - 12 - □ - W	NEMA 12
JB - 13 - □ - W	NEMA 13

CODE □	HEIGHT D	WIDTH W	DEPTH G
10	10.00	8.00	4.00
12	12.00	10.00	5.00
14	14.00	12.00	6.00
16	16.00	14.00	6.00

Substitute code above for "®" to complete Model Number.

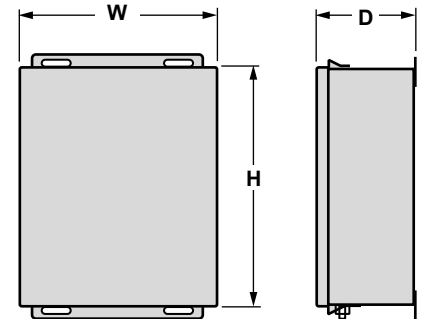

Substitute "S" for "W" in model number above for Rail Mounted junction box.

Terminal Blocks

MODEL NUMBER	S	MAX RATED AMPERES	FOR AWG SIZES
TB - 050	0.38	50	#24 thru #10
TB - 090	0.56	90	#8 thru #6
TB - 155	0.75	155	#4 thru #2
TB - 270	1.19	270	#1 thru #3/0

Ampere ratings above are general guidelines. Consult NEC for specific data.

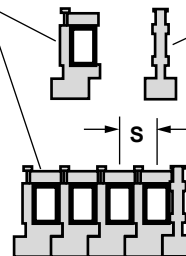

End Sections

MODEL NUMBER
TE - 050
TE - 090
TE - 155
TE - 270

Terminal Track Assembly

MODEL NUMBER	STYLE
TT - □ - S	Single
TT - □ - D	Double

Tracks mount in junction boxes and hold terminal blocks.

CODE □	HEIGHT D	WIDTH W
10	9.44	7.00
12	11.44	9.00
14	13.44	11.00
16	15.44	13.00

Substitute code above for "®" to complete Model Number.

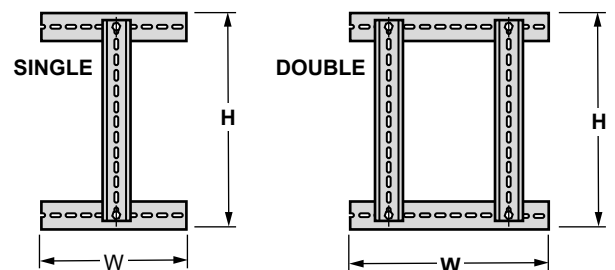

Accessories and Options for I152 & I162 only

Stainless Steel Cable Clips

- STAINLESS STEEL FOR LONG LIFE
- GREATER HOLDING POWER
- EASIER CABLE REPLACEMENT

Use of Cable Clips is recommended whenever there is high speed travel or when cables vary a great deal in size. Clips hook securely into saddle groove and may be easily moved to adjust cable spacing. To order clips, replace **S** or **D** with **C** in trolley model numbers.

MODEL NUMBER	CABLE DIAMETER		WIDTH "A"	
	in.	mm	in.	mm
CLP-01	0.50-0.75	(13-19)	0.97	(25)
CLP-02	0.75-1.00	(19-25)	1.28	(33)
CLP-03	1.00-1.25	(25-32)	1.47	(37)
CLP-04	1.25-1.50	(32-38)	1.72	(44)
CLP-05	1.50-1.75	(38-44)	1.97	(50)
CLP-06	1.75-2.12	(44-54)	2.35	(60)

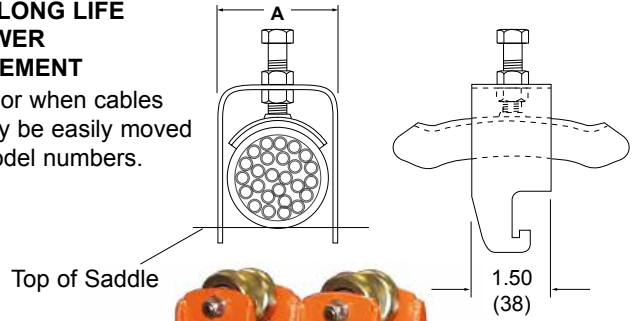

I152-C
Heavy Duty Trolley with Cable/Hose Clips

Heavy Duty Tow Ropes

Vinyl coated .38/.44" wire rope.
-Heavy duty steel shackles included.

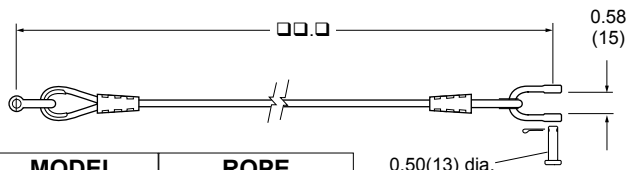

MODEL NUMBER	ROPE MATERIAL
TRH-□□.□-Z	Galvanized steel
TRH-□□.□-S	Stainless steel

Substitute required length in **feet** for "□□.□" to complete Model Number. Round up to nearest half foot.

Heavy Duty Shock Cords

Designed specifically to survive the rigors of high speed container crane applications. Industrial grade 5/8" elastomeric cords with stainless steel ends fasten to posts on trolleys.

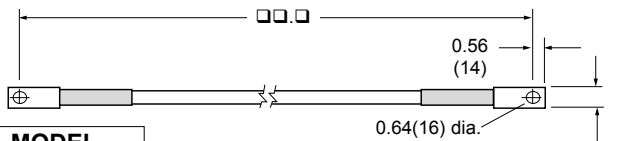

MODEL NUMBER
SCH-□□.□

Substitute required length in **feet** for "□□.□" to complete Model Number. Round up to nearest half foot.

Single Loop Clamps

Clamping pads are neoprene. Standard hardware is zinc plated steel. Finish is orange polyester powder.

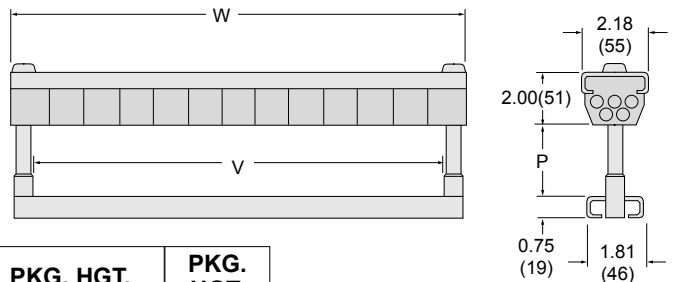

PKG. HGT. RANGE "P"	PKG. HGT. CODE □
0.45-0.95 (11-24)	1
0.65-1.15 (17-29)	2
1.04-1.54 (26-39)	3
1.44-1.94 (37-49)	4
1.83-2.33 (46-59)	5
2.22-2.72 (56-69)	6
2.70-3.51 (69-89)	7

MODEL NUMBER	WINDOW "V"	WIDTH "W"
CLH-S09-□-Z	9.18 (233)	11.06 (281)
CLH-S12-□-Z	12.81 (325)	14.68 (373)

May be supplied with stainless steel hardware. Substitute "S" for "Z" in model numbers above.

Package Height (o.d. of largest cable) Code is substituted for □ to complete model number. Table also applies to Double Clamps, left.

Dual Loop Clamps

Clamping pads are neoprene. Standard hardware is zinc plated steel. Finish is orange polyester powder.

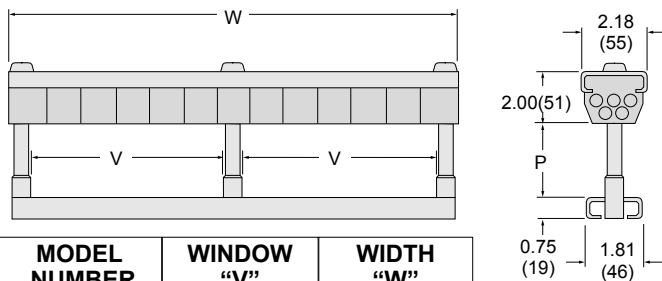

MODEL NUMBER	WINDOW "V"	WIDTH "W"
CLH-D07-□-Z	8.78 (223)	20.06 (510)
CLH-D10-□-Z	11.06 (277)	24.62 (625)
CLH-D12-□-Z	13.83 (351)	30.17 (766)

See PACKAGE HEIGHT CODE table above for "P".

Stainless steel hardware optional. Substitute "S" for "Z" in model numbers above.

Bar Cable Loop Clamps

One half inch thick aluminum bars, custom milled to your requirements. Rounded edges reduce cable wear. Stainless steel fasteners. Consult factory for more information.

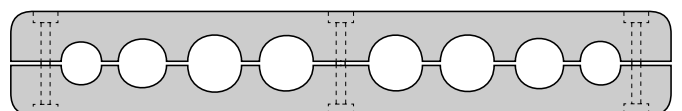

Available Options

Options are available for most typical requirements and many truly special situations. These pages list a few of the most commonly requested options. If you don't see what you need, *JUST CALL!*

1. Other Wheel Types and/or Materials

Steel crowned wheels are standard. Nylon crowned wheels and steel flanged wheels are also available. See model detail pages for more information. NOTE: Nylon flanged wheels are not available.

2. Lubrication Option

Standard load-carrying wheels, side-guide rollers and anti-lift rollers are lubricated for life and sealed. A re-greasable option is available for load-carrying wheels only.

3. Stainless Steel Hardware

 Available on all series as noted on each model detail page.

4. Finishes

STANDARD FINISH

Standard Gleason finish is thermoset polyester powder coating. Standard color is safety orange.

OPTIONAL FINISHES

Hot dipped galvanizing and other finishes may be specified to suit unique conditions. When specifying other finishes, please provide detailed specifications, as finishes tend to be a localized matter to satisfy local conditions. For example, inland suppliers may not easily identify coastal specs, etc.

5. Curved I-Beam

Festoon systems mounted on curved I-beams (photo, right) require special attention. Please contact us with your specific need.

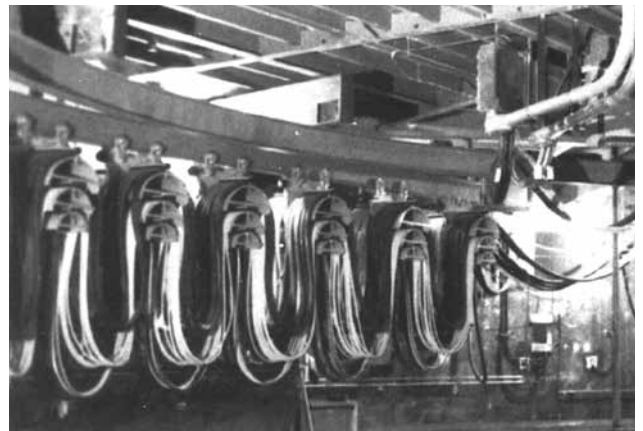

6. Non-Standard Designs

Special designs are available to meet your application requirements. Contact us with specific details.

7. Pre-Assembly and Shipping Frame

To speed and simplify festoon system installation, Gleason offers complete factory pre-assembly. Experienced personnel will assemble all components into their proper operating relationships. This reduces on-site time costs and possible confusion for new installers.

Your system will be shipped to you mounted on a shipping frame which is designed to allow your installation crew to transfer the system directly onto your I-beam.

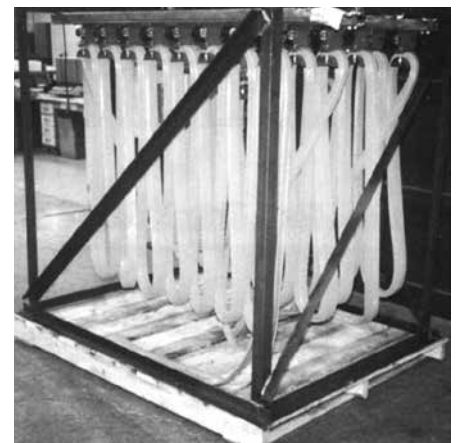

Available Options, con't.

8. Additional Saddles

SERIES I120, I130, I152 & I162

SADDLES 14.12" DIA. OR LARGER

Large cable packages may require more than one saddle, especially if there is not room for a wide saddle. A second or third saddle can be added to accommodate large loads, up to the weight limit of the trolley. Contact us for details.

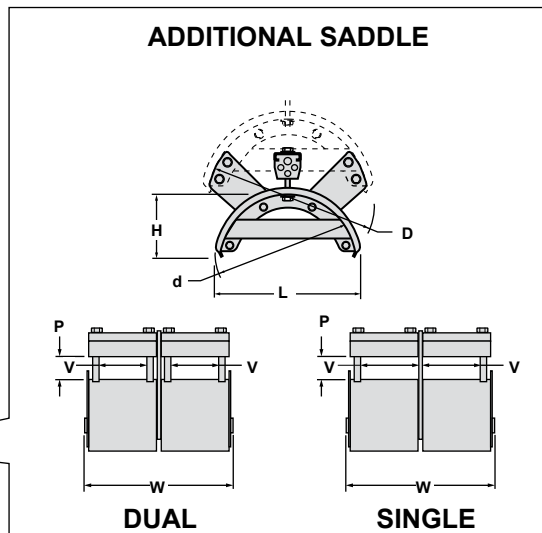
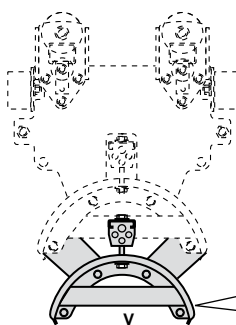

Single Clamp Design

Model Number W/ Std. Hardware	Saddle Radius	Saddle Dia. D	Add'l Dia. d	Window Height P	Window Width V	Overall Length L	Overall Width W	Below Saddle H
AS-14-S10-1004-Z	7.06	14.12	10.25	1.06	4.38	12.25	11.44	5.00
AS-14-S10-1006-Z	7.06	14.12	10.25	1.06	6.19	12.25	15.06	5.00
AS-18-S10-1004-Z	9.06	18.12	10.25	1.06	4.38	12.25	11.44	5.66
AS-18-S10-1006-Z	9.06	18.12	10.25	1.06	6.19	12.25	15.06	5.66
AS-18-S14-1404-Z	9.06	18.12	14.12	1.44	4.38	16.12	11.44	6.97
AS-18-S14-1406-Z	9.06	18.12	14.12	1.44	6.19	16.12	15.06	6.97

NOTE:
Primary saddle with "D" diameter accepts additional saddle with "d" diameter.

Dual Clamp Design

Model Number W/ Std. Hardware	Saddle Radius	Saddle Dia. D	Add'l Dia. d	Window Height P	Window Width V	Overall Length L	Overall Width W	Below Saddle H
AS-14-D10-1007-Z	7.06	14.12	10.25	1.06	7.88	12.25	20.44	5.00
AS-14-D10-1012-Z	7.06	14.12	10.25	1.06	12.69	12.25	30.06	5.00
AS-18-D10-1007-Z	9.06	18.12	10.25	1.06	7.88	12.25	20.44	5.66
AS-18-D10-1012-Z	9.06	18.12	10.25	1.06	12.69	12.25	30.06	5.66
AS-18-D14-1407-Z	9.06	18.12	14.12	1.44	7.88	16.12	20.44	6.97
AS-18-D14-1412-Z	9.06	18.12	14.12	1.44	12.69	16.12	30.06	6.97

I-Beam Data

USE THESE TABLES AS A GUIDE ONLY!

Please refer to the Manual of Steel Construction for details. Beams marked with asterisk (*) are common to industry; we see them often when sizing festoon systems.

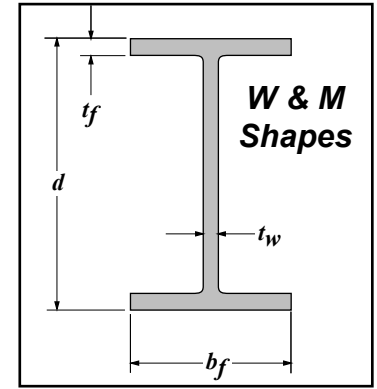
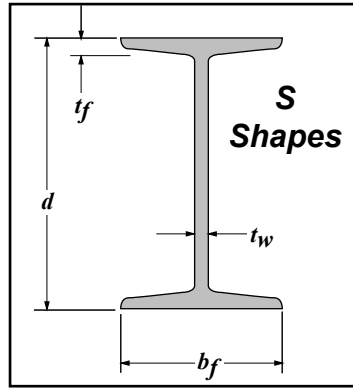

BEAM DESIGNATION	DEPTH d	WEB THICKNESS t_w	FLANGE WIDTH b_f	FLANGE THICKNESS t_f
* S 3x5.7	3.00	0.170	2.330	0.260
* S 3x7.5	3.00	0.349	2.509	0.260
* S 4x7.7	4.00	0.193	2.663	0.293
* S 4x9.5	4.00	0.326	2.796	0.293
* S 5x10	5.00	0.214	3.004	0.326
* S 5x14.75	5.00	0.494	3.284	0.326
* S 6x12.5	6.00	0.232	3.332	0.359
* S 6x17.25	6.00	0.465	3.565	0.359
* S 7x15.3	7.00	0.252	3.662	0.392
* S 7x20	7.00	0.450	3.860	0.392
* S 8x18.4	8.00	0.271	4.001	0.426
* S 8x23	8.00	0.441	4.171	0.426
* S 10x25.4	10.00	0.311	4.661	0.491
* S 10x35	10.00	0.594	4.944	0.491
* S 12x31.8	12.00	0.350	5.000	0.544
* S 12x35	12.00	0.428	5.078	0.544
* S 12x40.8	12.00	0.462	5.252	0.659
* S 12x50	12.00	0.687	5.477	0.659
* S 15x42.9	15.00	0.411	5.501	0.622
* S 15x50	15.00	0.550	5.640	0.622
* S 18x54.7	18.00	0.461	6.001	0.691
* S 18x70	18.00	0.711	6.251	0.691
S 20x66	20.00	0.505	6.255	0.795
* S 20x75	20.00	0.635	6.385	0.795
S 20x86	20.30	0.660	7.060	0.920
S 20x96	20.30	0.800	7.200	0.920
* S 24x80	24.00	0.500	7.000	0.870
S 24x90	24.00	0.625	7.125	0.870
* S 24x100	24.00	0.745	7.245	0.870
S 24x106	24.50	0.620	7.870	1.090
S 24x121	24.50	0.800	8.050	1.090
* M 4x13	4.00	0.254	3.940	0.371
* M 5x18.9	5.00	0.316	5.003	0.416
M 6x4.4	6.00	0.114	1.844	0.171
M 6x20	6.00	0.250	5.938	0.379
M 8x6.5	8.00	0.135	2.281	0.189
M 10x9	10.00	0.157	2.690	0.206
M 12x11.8	12.00	0.177	3.065	0.225
M 14x18	14.00	0.215	4.000	0.270
W 4x13	4.16	0.280	4.060	0.345
* W 5x16	5.01	0.240	5.000	0.360
* W 5x19	5.15	0.270	5.030	0.430
* W 6x9	5.60	0.170	3.940	0.215
* W 6x12	6.03	0.230	4.000	0.280
* W 6x15	5.99	0.230	5.990	0.260
* W 6x16	6.28	0.260	4.030	0.405
* W 6x20	6.20	0.260	6.020	0.365
* W 6x25	6.38	0.320	6.080	0.455
* W 8x10	7.89	0.170	3.940	0.205
* W 8x13	7.99	0.230	4.000	0.255
W 8x15	8.11	0.245	4.015	0.315
* W 8x18	8.14	0.230	5.250	0.330

BEAM DESIGNATION	DEPTH d	WEB THICKNESS t_w	FLANGE WIDTH b_f	FLANGE THICKNESS t_f
W 8x21	8.28	0.250	5.270	0.400
W 8x24	7.93	0.245	6.495	0.400
W 8x28	8.06	0.285	6.535	0.465
W 8x31	8.00	0.285	7.995	0.435
W 8x35	8.12	0.310	8.020	0.495
W 8x40	8.25	0.360	8.070	0.560
W 8x48	8.50	0.400	8.110	0.685
W 8x58	8.75	0.510	8.220	0.810
W 8x67	9.00	0.570	8.280	0.935
* W 10x12	9.87	0.190	3.960	0.210
* W 10x15	9.99	0.230	4.000	0.270
W 10x17	10.11	0.240	4.010	0.330
W 10x19	10.24	0.250	4.020	0.395
W 10x22	10.17	0.240	5.750	0.365
W 10x26	10.33	0.260	5.770	0.440
W 10x30	10.47	0.300	5.810	0.510
W 10x33	9.73	0.290	7.960	0.435
W 10x39	9.92	0.315	7.985	0.530
W 10x45	10.10	0.350	8.020	0.620
W 10x49	9.98	0.340	10.000	0.560
W 10x54	10.09	0.370	10.030	0.615
W 10x60	10.22	0.420	10.080	0.680
W 10x68	10.40	0.470	10.130	0.770
W 10x77	10.60	0.530	10.190	0.870
W 10x88	10.84	0.605	10.265	0.990
W 10x100	11.10	0.680	10.340	1.120
W 10x112	11.36	0.755	10.415	1.250
W 12x14	11.91	0.200	3.970	0.225
W 12x16	11.99	0.220	3.990	0.265
W 12x19	12.16	0.235	4.005	0.350
W 12x22	12.31	0.260	4.030	0.425
W 12x26	12.22	0.230	6.490	0.380
W 12x30	12.34	0.260	6.520	0.440
W 12x35	12.50	0.300	6.560	0.520
W 12x40	11.94	0.295	8.005	0.515
W 12x45	12.06	0.335	8.045	0.575
W 12x50	12.19	0.370	8.080	0.640
W 12x53	12.06	0.345	9.995	0.575
W 12x58	12.19	0.360	10.010	0.640
W 12x65	12.12	0.390	12.000	0.605
W 12x72	12.25	0.430	12.040	0.670
W 12x79	12.38	0.470	12.080	0.735
W 12x87	12.53	0.515	12.125	0.810
W 12x96	12.71	0.550	12.160	0.900
W 12x106	12.89	0.610	12.220	0.990
W 12x120	13.12	0.710	12.320	1.105
W 12x136	13.41	0.790	12.400	1.250
W 12x152	13.71	0.870	12.480	1.400
W 12x170	14.03	0.960	12.570	1.560
W 12x190	14.38	1.060	12.670	1.735
W 12x210	14.71	1.180	12.790	1.900
W 12x230	15.05	1.285	12.895	2.070
W 12x252	15.41	1.395	13.005	2.250
W 12x279	15.85	1.530	13.140	2.470
W 12x305	16.32	1.625	13.235	2.705
W 12x336	16.82	1.775	13.385	2.955

Flat Cable Data

NEOPRENE FLAT CABLE

AWG Size	No. Cond.	Thick x Width	Weight lb/ft
16	4	0.225 x 0.600	0.107
	7	0.225 x 0.995	0.188
	8	0.225 x 1.120	0.208
	10	0.245 x 1.420	0.288
	12	0.245 x 1.655	0.342
14	24	0.470 x 2.030	0.705
	4	0.275 x 0.785	0.181
	7	0.275 x 1.300	0.309
	8	0.275 x 1.455	0.350
12	12	0.295 x 2.165	0.557
	12	0.610 x 2.675	1.162
	4	0.335 x 0.945	0.268
10	7	0.335 x 1.535	0.457
	12	0.330 x 2.440	0.760
8	4	0.335 x 1.045	0.335
	7	0.355 x 1.730	0.577
6	4	0.415 x 1.300	0.510
	7	0.435 x 2.165	0.886
4	4	0.490 x 1.495	0.739
	7	0.510 x 2.640	1.324
2	4	0.550 x 1.810	1.061
	7	0.610 x 3.110	1.888
1/0	4	0.650 x 2.085	1.444
2/0	4	0.750 x 2.440	1.988
3/0	4	0.865 x 2.795	2.687
	4	0.965 x 3.190	3.675

PVC FLAT CABLE

AWG Size	No. Cond.	Thick x Width	Weight lb/ft
16	4	0.215 x 0.625	0.100
	8	0.215 x 1.160	0.180
	12	0.215 x 1.655	0.270
14	4	0.225 x 0.655	0.120
	8	0.225 x 1.225	0.220
	12	0.225 x 1.750	0.340
12	4	0.245 x 0.740	0.160
	5	0.245 x 0.895	0.210
	8	0.245 x 1.390	0.320
10	4	0.285 x 0.910	0.240
	8	0.385 x 1.240	0.420
6	4	0.450 x 1.500	0.600
	5	0.450 x 1.785	0.800
4	4	0.510 x 1.740	0.750
	4	0.580 x 2.005	1.270

MULTI-CABLE GLAND

Cast Aluminum

MODEL NUMBER	DESCRIPTION
GL-MA-01	Multi-cable Gland
GL-MA-CC	Cutting charge*

* Rubber insert ships UNCUT as standard. Gleason will machine to suit cable package for a nominal charge.

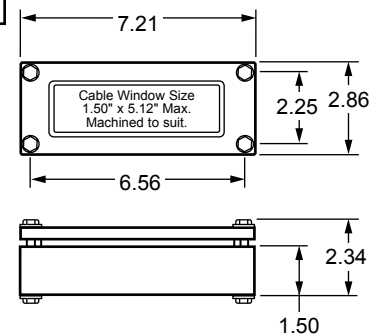

FLAT CABLE GLANDS

Brass

MODEL NUMBER
GL-FB-□

Plastic

MODEL NUMBER
GL-FP-□

CODE □	D	BRASS W	PLASTIC W	G	CLEARANCE HOLE REQ'D
16	0.00 - 0.20	0.00 - 0.63	0.00 - 0.59	1.14	0.906
21	0.12 - 0.31	0.35 - 0.83	0.35 - 0.82	1.40	1.125
29	0.16 - 0.45	0.55 - 1.18	0.55 - 1.02	1.81	1.469
36	0.16 - 0.45	0.94 - 1.57	0.94 - 1.34	2.21	1.875
42	0.20 - 0.47	1.14 - 1.77	1.14 - 1.57	2.56	2.125
48	1.20 - 0.47	1.34 - 1.97	1.14 - 1.77	2.72	2.375

Code is substituted for □ to complete model number

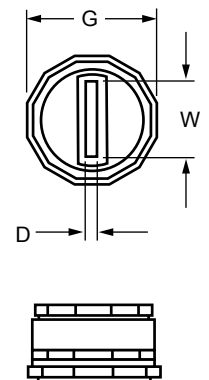

ROUND CABLE GLANDS

Brass

MODEL NUMBER
GL-RB-□

Code is substituted for □ to complete model number

Plastic

MODEL NUMBER
GL-RP-□

CODE □	D	G	CLEARANCE HOLE REQ'D
09	0.196 - 0.315	0.75	0.609
11	0.275 - 0.492	0.93	0.750
13	0.275 - 0.590	1.00	0.812
16	0.315 - 0.630	1.14	0.906
21	0.433 - 0.866	1.40	1.125
29	0.748 - 1.220	1.81	1.469
36	0.984 - 1.378	2.21	1.875
42	1.397 - 1.811	2.56	2.125
48	1.594 - 1.988	2.72	2.375

CODE □	D	G	CLEARANCE HOLE REQ'D
07	0.090 - 0.265	0.72	0.500
09	0.187 - 0.312	0.75	0.609
11	0.231 - 0.394	0.93	0.750
13	0.270 - 0.480	1.00	0.812
16	0.428 - 0.546	1.14	0.906
21	0.545 - 0.709	1.40	1.125
29	0.709 - 1.000	1.81	1.469

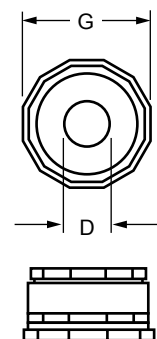

Flat Cable Data

NEOPRENE FLAT CABLE

AWG Size	No. Cond.	Thick x Width	Weight lb/ft
16	4	0.225 x 0.600	0.107
	7	0.225 x 0.995	0.188
	8	0.225 x 1.120	0.208
	10	0.245 x 1.420	0.288
	12	0.245 x 1.655	0.342
14	24	0.470 x 2.030	0.705
	4	0.275 x 0.785	0.181
	7	0.275 x 1.300	0.309
	8	0.275 x 1.455	0.350
	12	0.295 x 2.165	0.557
12	24	0.610 x 2.675	1.162
	4	0.335 x 0.945	0.268
	7	0.335 x 1.535	0.457
10	12	0.330 x 2.440	0.760
	4	0.335 x 1.045	0.335
8	7	0.355 x 1.730	0.577
	4	0.415 x 1.300	0.510
6	7	0.435 x 2.165	0.886
	4	0.490 x 1.495	0.739
4	7	0.510 x 2.640	1.324
	4	0.550 x 1.810	1.061
2	7	0.610 x 3.110	1.888
	4	0.650 x 2.085	1.444
1/0	4	0.750 x 2.440	1.988
2/0	4	0.865 x 2.795	2.687
3/0	4	0.965 x 3.190	3.675

PVC FLAT CABLE

AWG Size	No. Cond.	Thick x Width	Weight lb/ft
16	4	0.215 x 0.625	0.100
	8	0.215 x 1.160	0.180
	12	0.215 x 1.655	0.270
14	4	0.225 x 0.655	0.120
	8	0.225 x 1.225	0.220
	12	0.225 x 1.750	0.340
12	4	0.245 x 0.740	0.160
	5	0.245 x 0.895	0.210
	8	0.245 x 1.390	0.320
10	4	0.285 x 0.910	0.240
8	4	0.385 x 1.240	0.420
	4	0.450 x 1.500	0.600
6	5	0.450 x 1.785	0.800
	4	0.510 x 1.740	0.750
2	4	0.580 x 2.005	1.270

MULTI-CABLE GLAND

Cast Aluminum

MODEL NUMBER	DESCRIPTION
GL-MA-01	Multi-cable Gland
GL-MA-CC	Cutting charge*

* Rubber insert ships UN-CUT as standard. Gleason will machine to suit cable package for a nominal charge.

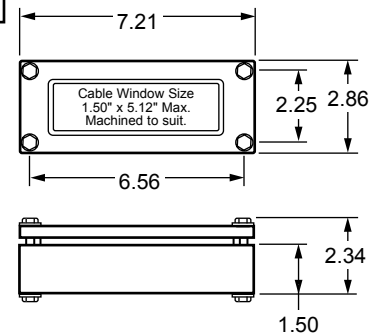

FLAT CABLE GLANDS

Brass

MODEL NUMBER
GL-FB-□

Plastic

MODEL NUMBER
GL-FP-□

CODE □	D	BRASS W	PLASTIC W	G	CLEARANCE HOLE REQ'D
16	0.00 - 0.20	0.00 - 0.63	0.00 - 0.59	1.14	0.906
21	0.12 - 0.31	0.35 - 0.83	0.35 - 0.82	1.40	1.125
29	0.16 - 0.45	0.55 - 1.18	0.55 - 1.02	1.81	1.469
36	0.16 - 0.45	0.94 - 1.57	0.94 - 1.34	2.21	1.875
42	0.20 - 0.47	1.14 - 1.77	1.14 - 1.57	2.56	2.125
48	1.20 - 0.47	1.34 - 1.97	1.14 - 1.77	2.72	2.375

Code is substituted for □ to complete model number

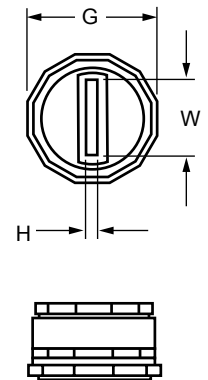

ROUND CABLE GLANDS

Brass

MODEL NUMBER
GL-RB-□

Code is substituted for □ to complete model number

Plastic

MODEL NUMBER
GL-RP-□

CODE □	D	G	CLEARANCE HOLE REQ'D
09	0.196 - 0.315	0.75	0.609
11	0.275 - 0.492	0.93	0.750
13	0.275 - 0.590	1.00	0.812
16	0.315 - 0.630	1.14	0.906
21	0.433 - 0.866	1.40	1.125
29	0.748 - 1.220	1.81	1.469
36	0.984 - 1.378	2.21	1.875
42	1.397 - 1.811	2.56	2.125
48	1.594 - 1.988	2.72	2.375

CODE □	D	G	CLEARANCE HOLE REQ'D
07	0.090 - 0.265	0.72	0.500
09	0.187 - 0.312	0.75	0.609
11	0.231 - 0.394	0.93	0.750
13	0.270 - 0.480	1.00	0.812
16	0.428 - 0.546	1.14	0.906
21	0.545 - 0.709	1.40	1.125
29	0.709 - 1.000	1.81	1.469

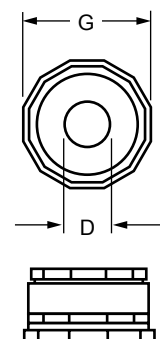

Round Cable & Hose Data

TYPE SO CABLE — 600 VOLT

16 AWG			14 AWG			12 AWG			10 AWG		
No. Cond.	Dia. In.	Weight lb/ft	No. Cond.	Dia. In.	Weight lb/f	No. Cond.	Dia. In.	Weight lb/f	No. Cond.	Dia. In.	Weight lb/f
2	0.374	0.094	2	0.512	0.158	2	0.586	0.204	2	0.638	0.250
3	0.393	0.110	3	0.538	0.184	3	0.616	0.244	3	0.671	0.310
4	0.427	0.144	4	0.584	0.224	4	0.668	0.282	4	0.730	0.371
5	0.510	0.156	5	0.665	0.260	5	0.725	0.322	5	0.796	0.425
6	0.565	0.178	6	0.710	0.302	6	0.805	0.380	6	0.883	0.485
7	0.605	0.202	7	0.710	0.329	7	0.865	0.435	7	0.982	0.593
8	0.645	0.222	8	0.770	0.373	8	0.920	0.475	8	1.052	0.650
9	0.720	0.268	9	0.820	0.414	9	1.020	0.550	9	1.127	0.725
10	0.720	0.278	10	0.885	0.434	10	1.020	0.581	10	1.127	0.760
12	0.740	0.305	12	0.905	0.481	12	1.050	0.645	12	1.153	0.850
14	0.775	0.348	14	1.000	0.556	14	1.105	0.743	14	1.287	1.118
16	0.825	0.386	16	1.050	0.657	16	1.160	0.840	20	1.455	1.400
18	0.860	0.430	18	1.110	0.715	18	1.227	0.925			
20	0.900	0.466	20	1.150	0.785	20	1.287	1.005			
22	0.940	0.503	22	1.210	0.857	22	1.370	1.140			
24	1.015	0.564	24	1.320	0.920	24	1.443	1.225			
26	1.015	0.604	26	1.350	0.986						
28	1.070	0.654	28	1.370	1.098						
30	1.070	0.677	30	1.390	1.138						
32	1.120	0.714									
34	1.155	0.807									
36	1.155	0.820									

TYPE W CABLE — 600 VOLT

AWG Size	No. Cond.	Dia. In.	Weight lb/ft
8	1	0.454	0.137
	2	0.788	0.328
	3	0.894	0.470
	4	0.966	0.583
6	1	0.539	0.199
	2	0.872	0.425
	3	0.983	0.614
	4	1.068	0.769
	5	1.159	0.938
4	1	0.596	0.267
	2	1.040	0.780
	3	1.068	0.797
	4	1.166	1.019
	5	1.335	1.307
2	1	0.666	0.365
	2	1.177	0.888
	3	1.244	1.152
	4	1.326	1.429
1	3	1.413	1.491
	4	1.548	1.877
1/0	1	0.796	0.543
	2	1.454	1.386
	3	1.539	1.805
	4	1.686	2.309
2/0	1	0.849	0.649
	2	1.555	1.640
	3	1.647	2.154
	4	1.807	2.738
3/0	4	1.942	3.320
4/0	1	0.973	0.940
	3	1.933	3.147
	4	2.100	4.044
250	1	1.055	1.113
350	1	1.174	1.471
500	1	1.325	2.007

TYPE G-GC CABLE — 600 VOLT

AWG Size	No. Cond.	Dia. In.	Weight lb/ft
8	3	0.915	0.661
6	3	1.000	0.792
4	3	1.120	1.088
2	3	1.250	1.436
1	3	1.440	1.856
1/0	3	1.565	2.270
2/0	3	1.630	2.660
3/0	3	1.800	3.290
4/0	3	2.025	4.147
250	3	2.280	5.108
350	3	2.635	7.058
500	3	2.865	8.900

Whenever possible, refer to specific manufacturer's information regarding cable or hose. If this information is not available, these charts are composites and may be used as guides to typical cable and hose size and weights.

Refer to the National Electric Code for ampere ratings and other details.

HOSE GENERAL PURPOSE

Listings for general purpose hose do NOT include fluid weight. Specific fluid weights should be added when figuring Total Cable/Hose Weight.

I.D. In.	Braid	O.D. In.	PSI (working)	Weight lb/ft
.25	2	0.59	300	0.13
.38	2	0.72	300	0.18
.50	2	0.88	300	0.23
.75	2	1.16	300	0.37
1.00	2	1.44	300	0.64
1.25	2	1.78	300	1.01
1.50	2	2.03	300	1.06

HOSE SINGLE HYDRAULIC

Listings for single hydraulic hose do NOT include fluid weight. Specific fluid weights should be added when figuring Total Cable/Hose Weight.

I.D. In.	Braid	O.D. In.	PSI (working)	Weight lb/ft
.25	2	0.58	5000	0.23
.38	2	0.73	4000	0.35
.50	2	0.86	3500	0.42
.75	2	1.14	2250	0.60
1.00	2	1.48	2000	0.89
1.25	2	1.87	1625	1.40

Cable Management

Since 1911, Gleason Reel Corp. has been in the business of CABLE MANAGEMENT. Our products are designed to convey and protect valuable cables and hoses that power and control moving machines of all types. They improve productivity and safety on the job by moving cables and hoses away from hazardous locations on machinery or the shop floor into a controlled environment. Whether you choose Reels for efficient storage and payout from virtually any angle, Festoon Systems for overhead applications or PowerTrak® for protection on machinery in motion, your cables and/or hoses will last longer and provide better service with a cable management system from **Gleason Reel Corp...**

...The Cable & Hose Management Company!



Bulletin "CR"
Heavy Duty
Spring Driven
Electric Cable Reels
General Industrial



Bulletin "MR"
Extra Heavy Duty
Spring Driven
Electric Cable Reels
Demanding Service

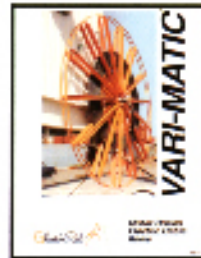

Bulletin "VMR"
Large Retrieving
Motor Driven
Electric Cable Reels
Heavy Duty Industrial



Bulletin "RET"
Long Travel Length
Motor Driven
Electric Cable Reels
Standard Industrial



Bulletin "PSR"
Lifting & Lowering
Motor Driven
Electric Cable Reels
Push-Button Reels



**Cable and Hose Reels
for Emergency Vehicles
Specialty Reels**

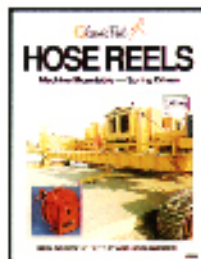

Bulletin "HRM"
Various Types
Spring Driven
Hose Reels
General Industrial



Bulletin "SR"
Slip Rings
Unitized Design
Low & High Amperage
Low & Medium Voltage



Bulletin "PTG"
Non-Metallic
Cable Chain
For Hose & Cable
Lightweight, Economical

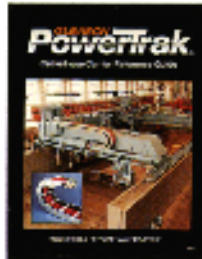

Bulletin "PT"
Rugged Steel
Cable Chain
For Hose & Cable
Standard & Mill Duty



Bulletin "FC"
Rugged Steel
C-Rail Mounted
Festoon Systems
General Industrial



Bulletin "FB"
Heavy Duty
I-Rail Mounted
Festoon Systems
Heavy Duty Port Types



A HUBBELL COMPANY

Gleason Reel Corp.

600 South Clark St.

Mayville, Wisconsin 53050

Phone: 920-387-4120

Fax: 920-387-4189

www.hubbell.com/gleasonreel/en

In your area contact: