

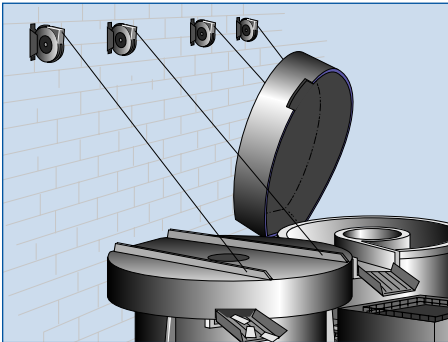

Workplace Solutions

REELS FOR PULLING & TUGGING VARIOUS LOADS

RETRIEVER REELS are designed to provide a "constant" pulling force over a specified distance. Working length (in feet) and pull (in pounds) shown in chart below. Reels feature rugged steel construction with polyester baked finish and rigid mounting bracket. Spring is permanently lubricated. Cable is 920 lb. (414kg) test 0.09"(2.3mm) dia. 7 x 7 strand galvanized steel aircraft cable nylon covered to 0.12"(3.0mm) O.D. Reels include end clip and adjustable cable stop. Net weight of all models 10 lbs.(4.5kg).



Sound dampening covers on vibrating cleaners make sound level in a metal finishing plant more acceptable. Two RETRIEVERS lift part of each cover's weight and make opening easier and safer.

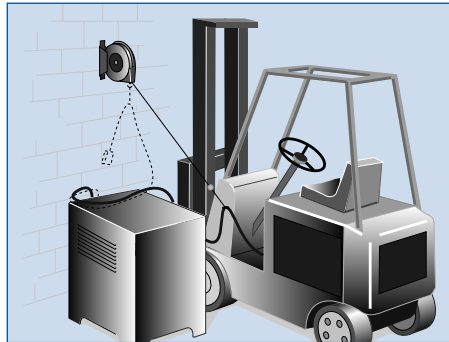

RETRIEVER keeps fork truck charging cables out of the way when not in use, reducing damage and need for costly replacement. Mount retriever on wall, as shown here, or directly on charger.

APPLICATION

RETRIEVER REELS are available in two mounting types: (A) with pull parallel to mounting surface. (B) with pull perpendicular to mount. Choose type which provides payout in direct line to attachment.

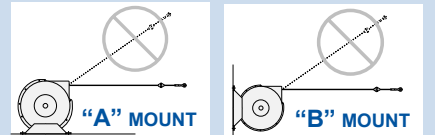

DIMENSIONS

ALL DIMENSIONS IN INCHES (mm)

"A" MOUNT-SERIES TQR

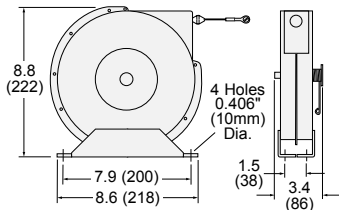

"B" MOUNT-SERIES TQV

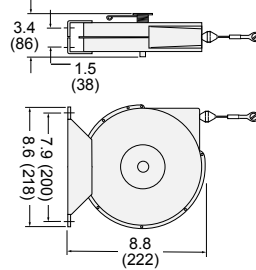

WORKING LENGTH CHART

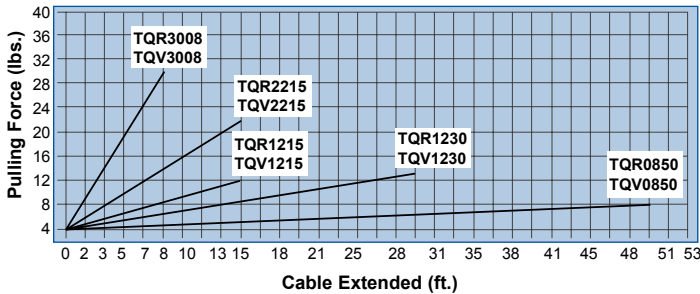

SELECTION CHART

CABLE LENGTH ft. (m)	MINIMUM PULL** lbs. (kg)	MAXIMUM PULL** lbs. (kg)	"A" MOUNT MODEL NO.	"B" MOUNT MODEL NO.
50 (15.0)	0.5 (0.2)	7.5 (3.4)	TQR0850	TQV0850
15 (4.5)	3.0 (1.4)	12.0 (5.4)	TQR1215	TQV1215
30 (9.0)	3.0 (1.4)	12.0 (5.4)	TQR1230	TQV1230
15 (4.5)	7.5 (3.4)	22.0 (9.9)	TQR2215	TQV2215
8 (2.4)	8.0 (3.6)	30.0 (13.5)	TQR3008	TQV3008

*Cable lengths listed are for "active" or "working" cable. Includes end clip and cable stop.
**Pulling forces above are approximate and depend on exact spring adjustment or pre-tensioning by the user. Reels are pre-set at the factory at the minimum pull. Adjusting reel to suit application is user's responsibility.

Packaging Workstation

Modular Design, Maximum Flexibility

Speed your shipments out the door. Shipping station kit was designed with utility and flexibility in mind. Strong, light weight extruded aluminum frame with steel joining brackets and maple bench tops may be assembled in a variety of configurations to fit your space and job requirements. Adjustable light with two 48" fluorescent lamps, packaging foam dispenser with cutting bar, adjustable shelf, power strip and swing arm mounted monitor and printer trays are included as standard. Unique wire trough on back helps organize and protect sensitive computer cables, power cords, etc. Station measures 120" long x 32.5" deep x 87" high in configuration shown. All metal parts have durable polyester finish. Aluminum is beige, steel brackets are matte black. All hardware is zinc plated steel.

DESCRIPTION	MODEL NO.
30" deep Packaging Workstation	HWS-STA120



NOTE: MONITOR, KEYBOARD, MOUSE, BAR CODE PRINTER, LABEL PRINTER AND OTHER SIMILAR EQUIPMENT ARE NOT INCLUDED