

Continuous Contact WB REELS

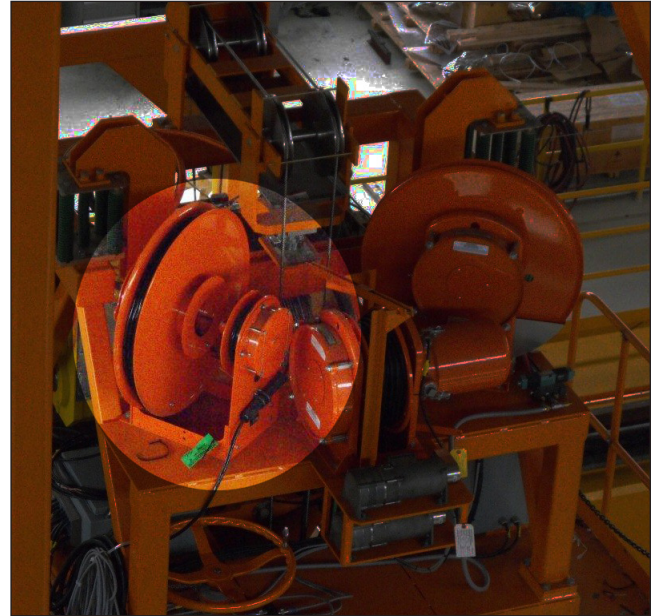
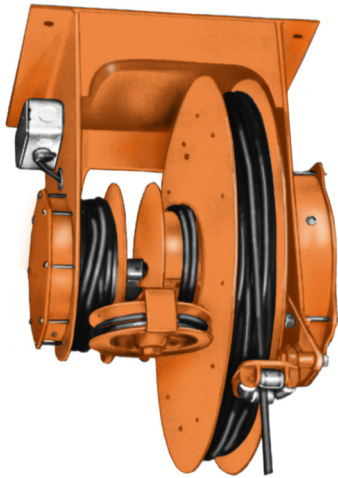

Gleason WB Reels are continuous contact reels ideal for use in applications where slip ring assemblies are not desired. No slip rings or other sliding contacts are used. Rather, a dual spool and pulley system safely and efficiently pays out and rewinds the cable.

The absence of electrical contact points on WB Reels make them an outstanding choice for applications involving portable or movable **communication or instrumentation equipment**. Such equipment could be adversely affected by the varying resistance of sliding electrical contacts or undue twisting of cords or cables resulting in varying impedance.

WB Reels are also a smart choice for **hazardous locations** where electrical parts on the reel would require dust-tight or explosion proof protection.

A roller guide is included as standard equipment. A holding dog for window shade-type action can be furnished when required.

FIBER OPTIC CABLE of same approximate O.D. as SO shielded cable listed can be used with Series "WB" reels. Contact your factory representative for details.

WB REEL SELECTION CHARTS

Reel models in selection charts based on travel speed of 150 fpm and 4 conductor shielded cable. Stretch reels based on 6% sag. Retrieve reels based on 3 ft. lift to center line of reel.

Necessary reeling tensions suggest the use of high quality cable for good service life.

FOR CABLE SIZES NOT LISTED, CONSULT FACTORY.
MAXIMUM CABLE O.D. = 0.625"

Lift Reels

WIRE SIZE (AWG)	FEET OF ACTIVE TRAVEL									
	30	40	50	60	70	80	90	100	110	120
18	WB-60-25	WB-60-25	WB-60-25	WB-60-25	WB-60-25	WB-100-60	WB-100-60	WB-100-60	WB-100-60	WB-100-60
16	WB-60-25	WB-60-25	WB-60-25	WB-60-25	WB-75-25	WB-100-60	WB-100-60	WB-100-60	WB-100-60	WB-100-100-60
14	WB-60-25	WB-60-25	WB-75-25	WB-100-60	WB-100-60	WB-100-60	WB-100-100-60	WB-100-100-60	WB-100-100-60	WB-100-100-60

Stretch Reels (6% sag)

WIRE SIZE (AWG)	FEET OF ACTIVE TRAVEL									
	30	40	50	60	70	80	90	100	110	120
18	WB-60-25	WB-60-25	WB-60-25	WB-75-25	WB-75-25	WB-100-60	WB-100-60	WB-100-60	WB-100-60	WB-100-60
16	WB-60-25	WB-60-25	WB-60-25	WB-75-25	WB-100-60	WB-100-60	WB-100-60	WB-100-60	WB-100-60	WB-100-100-60
14	WB-60-25	WB-60-25	WB-100-60	WB-100-60	WB-100-60	WB-100-100-60	WB-100-100-60	WB-100-100-60	WB-100-100-60	WB-100-100-60

Retrieve Reels (3 ft mounting height)

WIRE SIZE (AWG)	FEET OF ACTIVE TRAVEL									
	30	40	50	60	70	80	90	100	110	120
18	WB-60-25	WB-60-25	WB-60-25	WB-60-25	WB-60-25	WB-60-25	WB-100-60	WB-100-60	WB-100-60	WB-100-60
16	WB-60-25	WB-60-25	WB-60-25	WB-60-25	WB-75-25	WB-100-60	WB-100-60	WB-100-60	WB-100-60	WB-100-100-60
14	WB-60-25	WB-60-25	WB-60-25	WB-100-60	WB-100-60	WB-100-60	WB-100-100-60	WB-100-100-60	WB-100-100-60	WB-100-100-60

Dimensional Data

FIBER OPTICS

Any fiber optic cable of the same approximate O.D. as SO shielded cable listed can be used with Series "WB" reels. Contact your local factory representative for details.

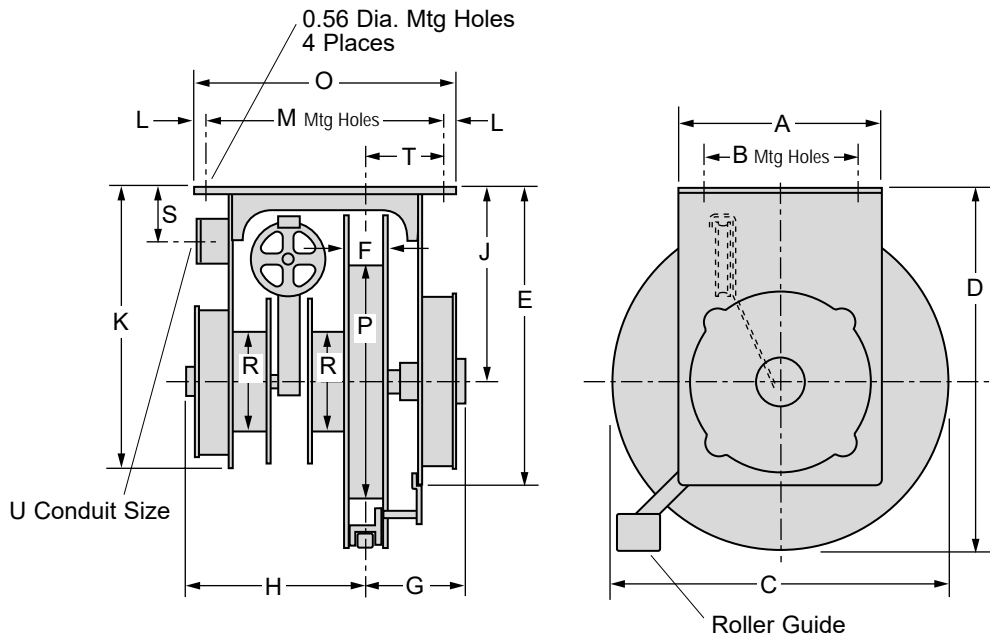

MODEL	A	B	C	D	E	F	G	H	J	K	L	M	N	O	P	R	S	T	U
WB-60-25	12.00	9.00	20.00	21.69	17.69	2.00	5.88	10.50	11.69	16.69	0.75	13.88	0.75	15.37	14.00	6.00	3.25	4.75	0.50
WB-75-25	12.00	9.00	27.00	28.69	20.75	2.00	6.81	10.75	15.19	19.69	0.75	13.88	0.75	15.37	22.00	6.00	6.69	4.63	0.50

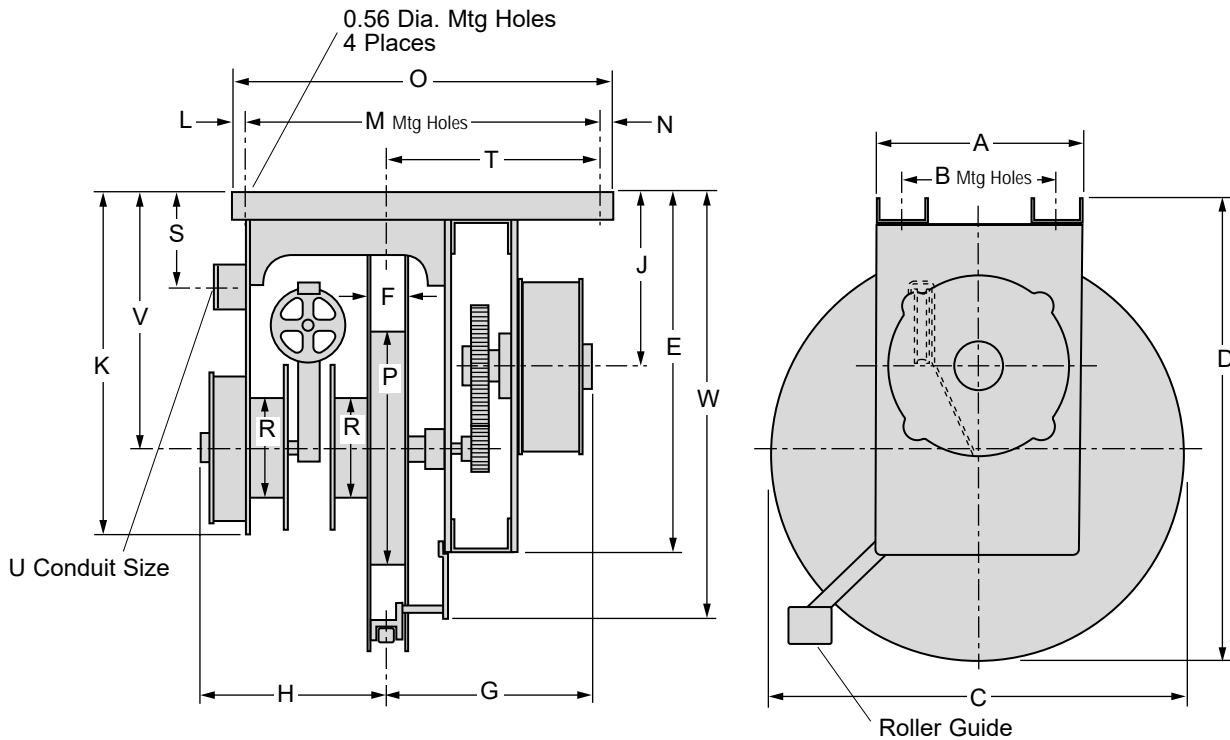

MODEL	A	B	C	D	E	F	G	H	J	K	L	M	N	O	P	R	S	T	U	V	W
WB-100-60	12.00	9.00	24.00	27.19	18.19	2.00	11.75	10.50	10.19	21.56	0.75	20.75	1.50	23.00	14.00	6.00	4.19	11.44	0.75	15.19	21.69
WB-100-100-60	12.00	9.00	28.00	31.19	20.19	2.00	16.00	10.75	12.19	23.56	0.75	20.75	1.50	23.00	16.00	6.00	6.00	11.44	0.75	17.19	23.69