



GLEASON SERIES SHO-101A REEL SPECIAL MAGNET REEL



These compact, rugged **GLEASON SHO-101A REELS** have gained much favor with the scrap handling industry and manufacturers of magnet handling cranes. Designed to fit within the crane boom, it is the answer to magnet cable handling problems. Constructed entirely of steel with a powerful long-life main spring. Precision ball bearings are used throughout. Heavy cross section slip rings and copper-graphite brushes ensure electrical contact. Collector assembly rating - 2 pole, 75 amp, 600 volts.

Lifting Capabilities Two Conductor Cable

- 60 feet: #10 AWG 600 volt cable
- 65 feet: #8 AWG 600 volt cable
- 65 feet: #6 AWG 600 volt cable

Net Weight - 280 lbs.

Please consult factory for additional Options and Accessories not shown.

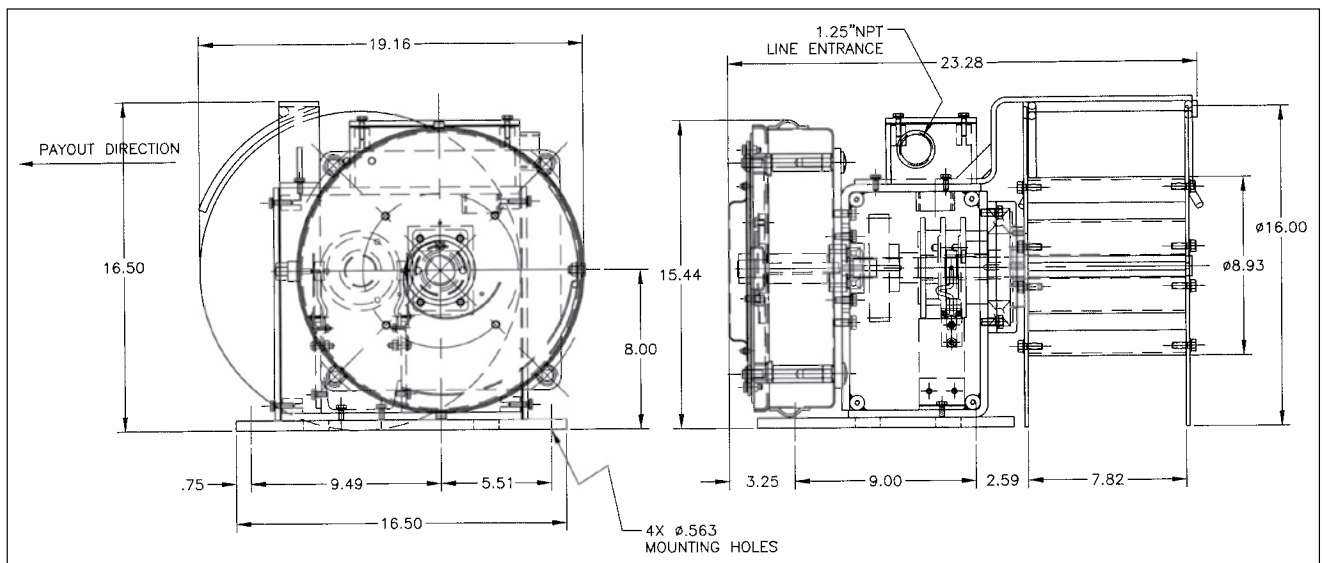

Gleason Reel Corp.

600 South Clark St.
Mayville, WI 53050
Phone: 920-387-4120
Fax: 920-387-4189
www.hubbell.com/gleasonreel/en