

# Rota-Power™ 200 Slip Rings

## 200A, 600V, 2" (51mm) Bore



**Rings:** Copper alloy for best combination of conductivity and durability, with wide contact area for maximum reliability

**Brushes:** Copper graphite, machined to precisely match ring radius

**Brush springs:** Zinc plated steel with quick-change design for easy field inspection

**Shunt wires:** Braided copper with jacket

**Insulators:** Phenolic

**End plates:** Nylon with phenolic bearing surfaces for durability and economy

**Drive collar:** Cast aluminum with double set screws for secure mounting at any attitude

**Speed:** Nominal 125 rpm, reversing

**Enclosures:** Durable steel with baked polyester powder finish to exceed zinc plating. Custom coatings available, Contact Gleason Reel for more options.

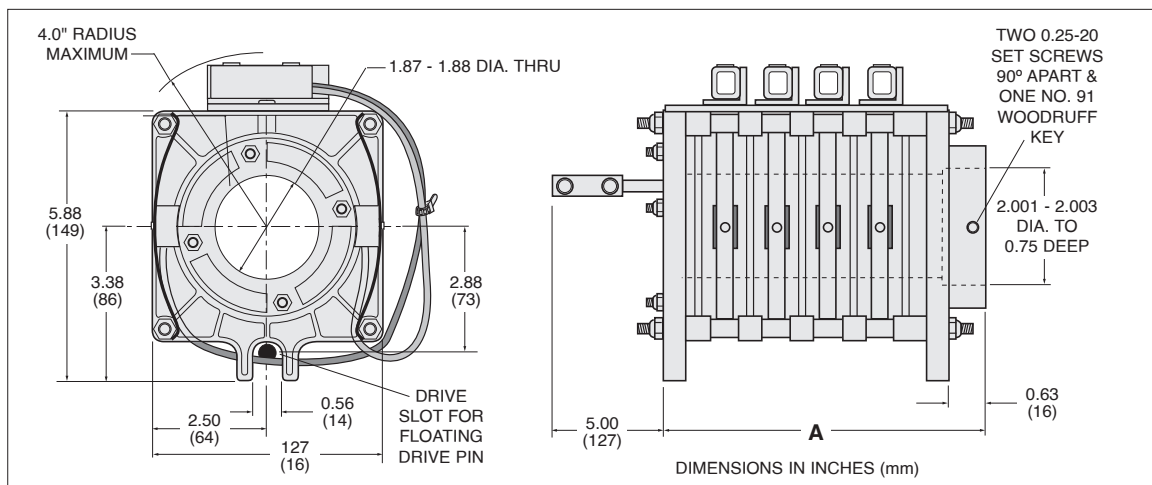

MODEL NUMBER	NUMBER POLES	ASSEMBLED IN.	LENGTH (A) (MM)	AWG LEAD*
RP200-02	2	5.13	(130)	Rod
RP200-03	3	6.51	(165)	Rod
RP200-04	4	7.88	(200)	Rod

\*Slip ring assemblies are supplied with 3/8" diameter copper rod leads and appropriate terminal connectors per the manufacturer and NEC standards

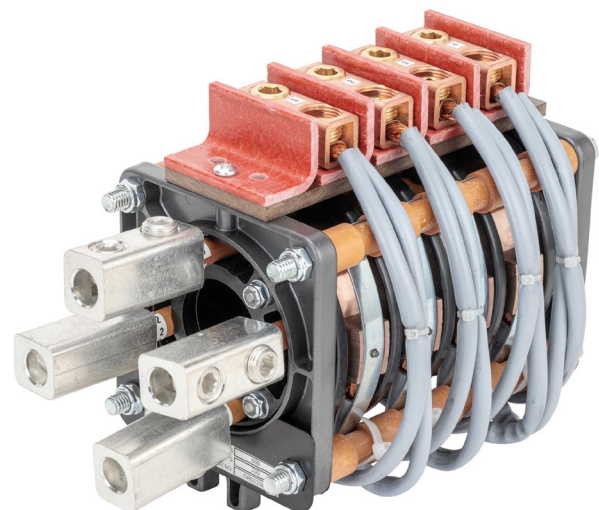

# Slip rings in enclosures

## Rota-Power™ 200 slip ring plus enclosure

**Weathertight:** Easy access Gleason slip ring enclosures are watertight and dust-tight. The sealed design keeps all but the most minute particles away from the working slip ring.

**Rugged construction:** Manufactured from medium gauge steel, enclosures are custom fit to each slip ring size. Main shafts are mounted on double ball bearings to support the slip ring assembly and enclosure.

**Weatherproof finish:** Enclosures feature a baked-on polyester finish for maximum durability in harsh conditions. Finish exceeds even zinc plating. Custom colors and finishes are available, contact us for details.

**Heaters:** For outdoor applications where machinery sits idle for extended periods of time or where low temperatures are common, we recommend installing a strip heater. Condensation can build up during shut-down periods, causing the slip ring assembly to require frequent service. The strip heater continuously eliminates condensation, increasing the service life of your Gleason Reel slip ring assembly.

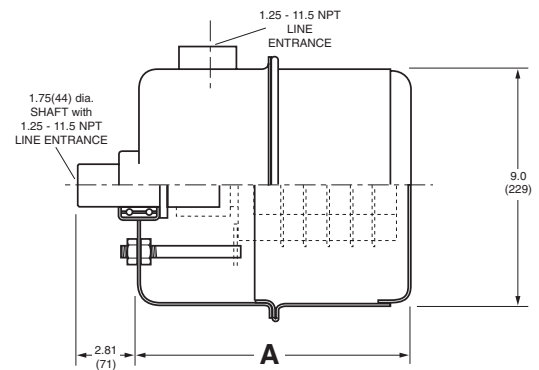

Model Number	Number Poles	Amps*	Assembled in.	Length (A) (mm)
ERP200-02	2	200.0	12.00	(305)
ERP200-03	3	200.0	14.50	(369)
ERP200-04	4	160.0	14.50	(369)

\* Amperage values in the above table are rated for 86°F (30°C) ambient temperature per NEC. For increased ambient temperatures, multiply the amperage value by the following scaling factors:

Ambient Temperature		Scaling factor
F°	C°	
140°	40°	0.91
122°	50°	0.82
140°	60°	0.71

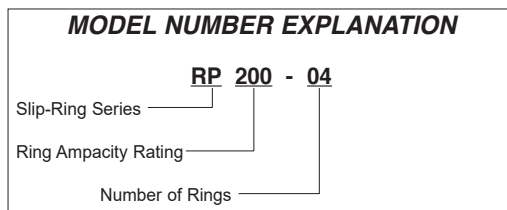

We reserve the right to ship the most current design

\*Slip ring assemblies are supplied with 3/8" diameter copper rod leads and appropriate terminal connectors per the manufacturer and NEC standards

Mount Gleason slip rings in virtually any position. Used in Gleason reels, they are mounted horizontally. In any configuration, it is possible for either the main shaft or the mounting surface to be in rotation.

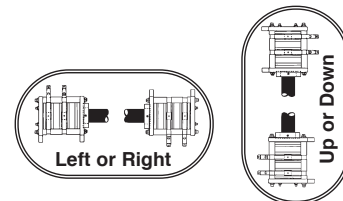

Please note: Bearing support on all slip rings intended for support of the slip ring only



A proud member of the Hubbell family.

©2023 Gleason Reel Corp. All rights reserved. Hubbell name and logo are trademarks or registered trademarks of Hubbell Incorporated. Other trademarks are property of their respective owners. 600 S. Clark Street, Mayville, WI 53050 www.hubbell.com/gleasonreel | (920) 387-4120

HHI-GR-GLEASON-SR200A-BR-EN-01454