

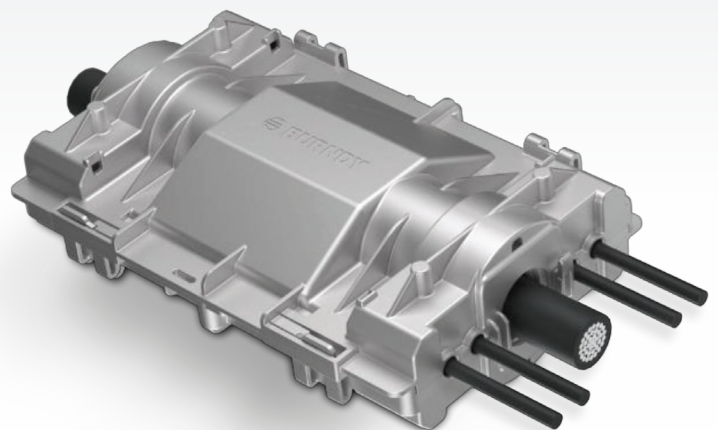



Compression Insulation Piercing Connector

Compression Flexible Trunk
Solution for Solar Farm
Applications





Burndy's cULus Listed Compression Flexible Trunk Solution (CFTS) wire connector product family is designed to deliver value while meeting the required solar standards for electrical, mechanical, and environmental performance. When comparing CFTS against other solutions, the CFTS checks the boxes.

CFTS Differentiators vs. Prefabrication Solutions

- ✓ **Flexible Trunk Bus Connection**
 - **Flexibility:** Install where you need it on the trunk bus to maximize tap wire conductor usage.
 - **Lead Time:** Field trunk installation requires limited product and prefab lead times ensuring your project is not held up and installed ON TIME!
 - **Efficient:** No need for a predetermined number of taps per connection, as the connector can accommodate 1-to-4 taps per connection.
 - **Cost Effective:** Up to 25% cost savings as compared to Prefab Solutions.

Key Points

- ✓ **Standards**
 - cULus Listed 486A-486B Wire Connector
 - UL 486D Sealed Wire Connector Compliant with Sequence E Rain, and Sequence H Sunlight Resistance
 - UL 94 V-0 Flammability Rating
- ✓ **Testing Requirements include:**
 - Static Heat Sequence, Current Cycle, Dielectric Withstand, Raintight, Sunlight/UV, and Impact Testing
- ✓ **Voltage Rating: 2kV**

CFTS Differentiators vs. Traditional Mechanical IPC

- ✓ **Compression vs. Mechanical**
 - **Quality:** CFTS are irreversible compression connectors providing greater repeatability during installation as compared to mechanical IPCs.
- ✓ **Fewer Connections**
 - **Cost Effective:** CFTS connectors are designed with 4-tap ports vs mechanical IPC connectors designed with single or dual tap ports, which provides significant savings on material and labour.
- ✓ **Installation Efficiency**
 - **Labour Savings:** Preinstalled whips for faster field installation saving time and cost.
- ✓ **Inspection/Validation**
 - **Inspection:** Die embossment of the trunk bus size on the trunk bus insulation of cable provide easy inspection.
 - **Validation:** T3 Technology - software technology in the compression tool to track, trace, and transmit data on connection validating proper installation while also geographical locations of all connections.
- ✓ **CFTS Covers vs. Mechanical IPC Covers**
 - **Quality:** Gel-filled seal is compliant with UL 486D Sealed Wire Connector standard Sequence E Rain and Sequence H Sunlight Resistant while competitors are not compliant.
 - **Strain Relief:** Unlike competitors which provide no strain relief, our cover is designed with strain relief, minimizing stress at the connection point.
 - **Safety Latches:** 8-safety latches deterring continuous opening.

Inspection

Installation dies emboss the main/run/trunk conductor size into the conductor insulation for connection inspection. Example: 500 kcmil AL main/run/trunk conductor embossment will be "500".

Product Standard

cULus Listed 486A-486B Wire Connector Standard Category ZMVV

- Test Requirements Include: static heating sequence, current cycling, dielectric withstanding, and drop testing



UL 486D Sealed Wire Connector Standard compliant with Sequences:

- Sequence E Rain Test Requirements Include: Rain, Immersion, and Dielectric Withstand
- Sequence H Sunlight Resistance Test Requirements Include: UV conditioning, impact, immersion, and dielectric-withstand

UL 94 Tests for Flammability of Plastic Materials for Parts in Devices and Applications:

- Polycarbonate cover material has a V-0 flame rating

UL 6703 Outline of Investigation for Connectors For Use in Photovoltaic Systems:

- Compliant with Requirement 4.2: UL 486A-486B Wire Connector Standard

Voltage Rating: 2kV

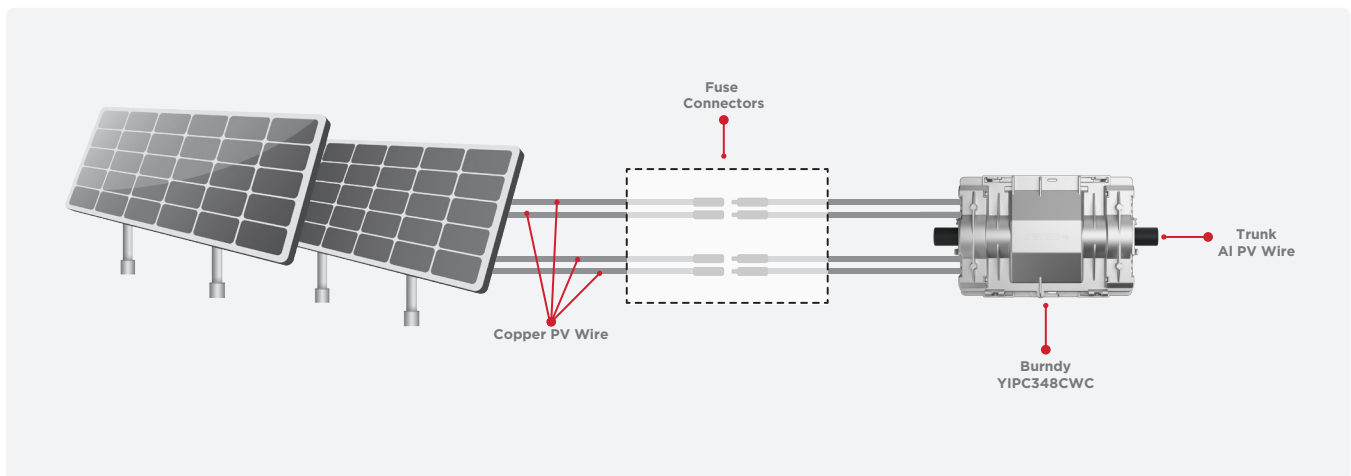

Body

- Uninsulated, tin-plated, aluminum extruded, H-Tap compression connectors
- Main / Run / Trunk Conductor Accommodates:
 - Three (3) unique designs that individually accommodate: 500 kcmil, 600 kcmil, and 750 kcmil
 - Intended to be used with stranded aluminum PV cable, rated 2 kV and 90°C
- Tap Wire Accommodates: 10 AWG and 8 AWG
 - Intended to be used with compact or concentric, 7 or 19 strand copper PV cable, rated 2 kV and 90°C
 - Required to use one (1) to four (4) tap wire ports per connection. Ports not being used can be left empty.
 - Tap wire requires stripping

Insulation Piercing Features

Five (5) piercing features maximize conductivity while maintaining thermal stability.

- Piercing Teeth: Three (3) full length insulation piercing teeth that penetrate the main/run/trunk wire insulation
- Piercing Legs: Two (2) full length piercing legs that wrap and penetrate the main/run/trunk conductor insulation

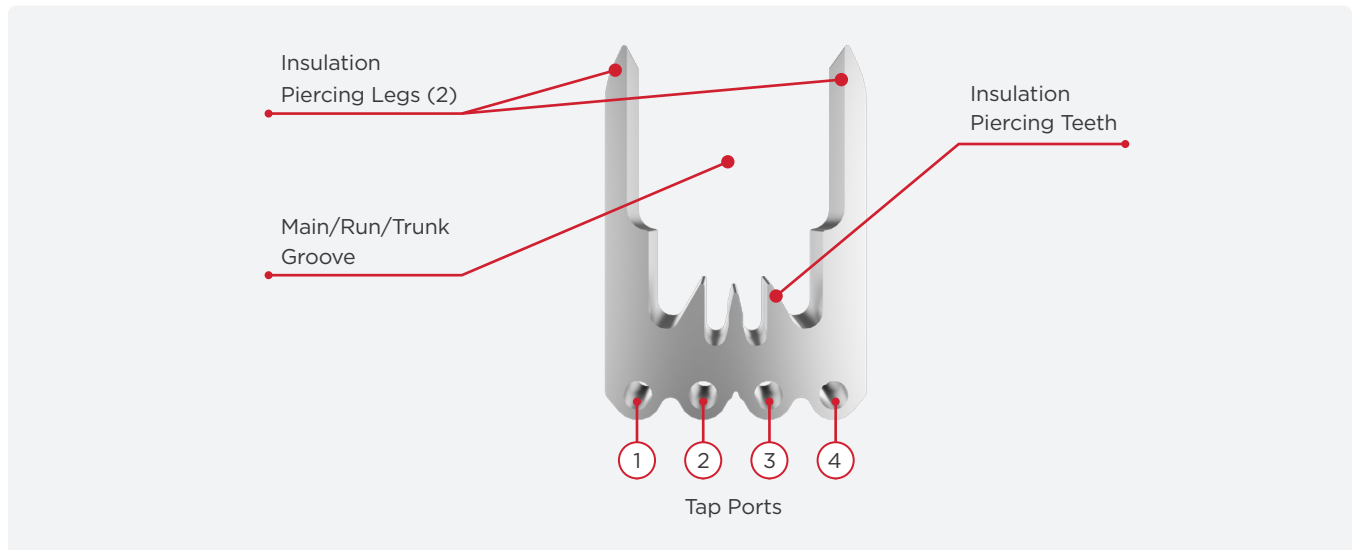

Die Profiles

- Upper Die: Rounding profile curls the piercing legs into the insulation of the main/run/trunk wire.
- Lower Die: Parallel ribs crimp tap wire(s) evenly. Includes a connector backstop, so the connector can be properly seated in the die prior to and during installation for proper alignment.

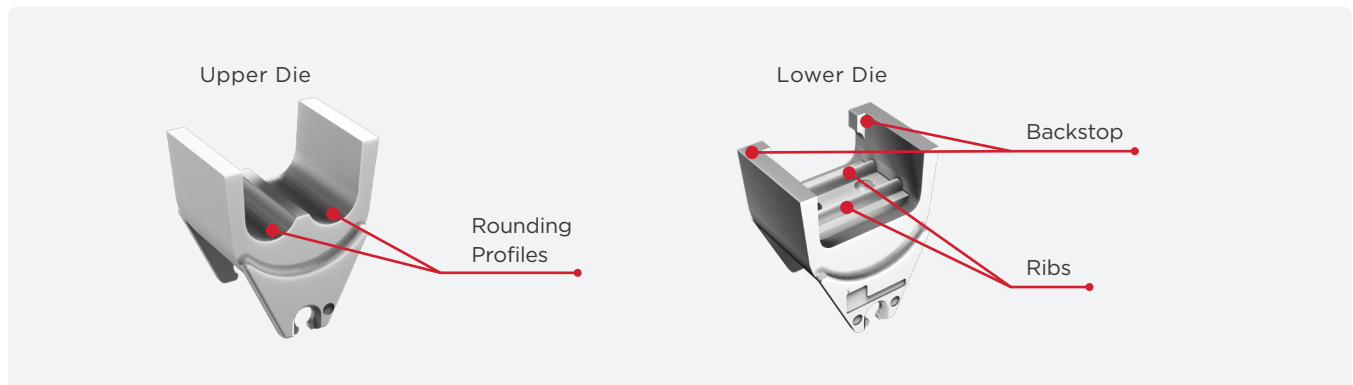

Installation

- Burndy's UL Listing certifies the use of this product with the BURNDY Engineered System. The use of other manufacturers' crimp tools and or dies for installation is not supported or warranted by Burndy. PAT46 Series with T3 technology tracks the data for each individual crimp, output force indicating a full crimp, date and time, and onboard GPS tracks crimp location.

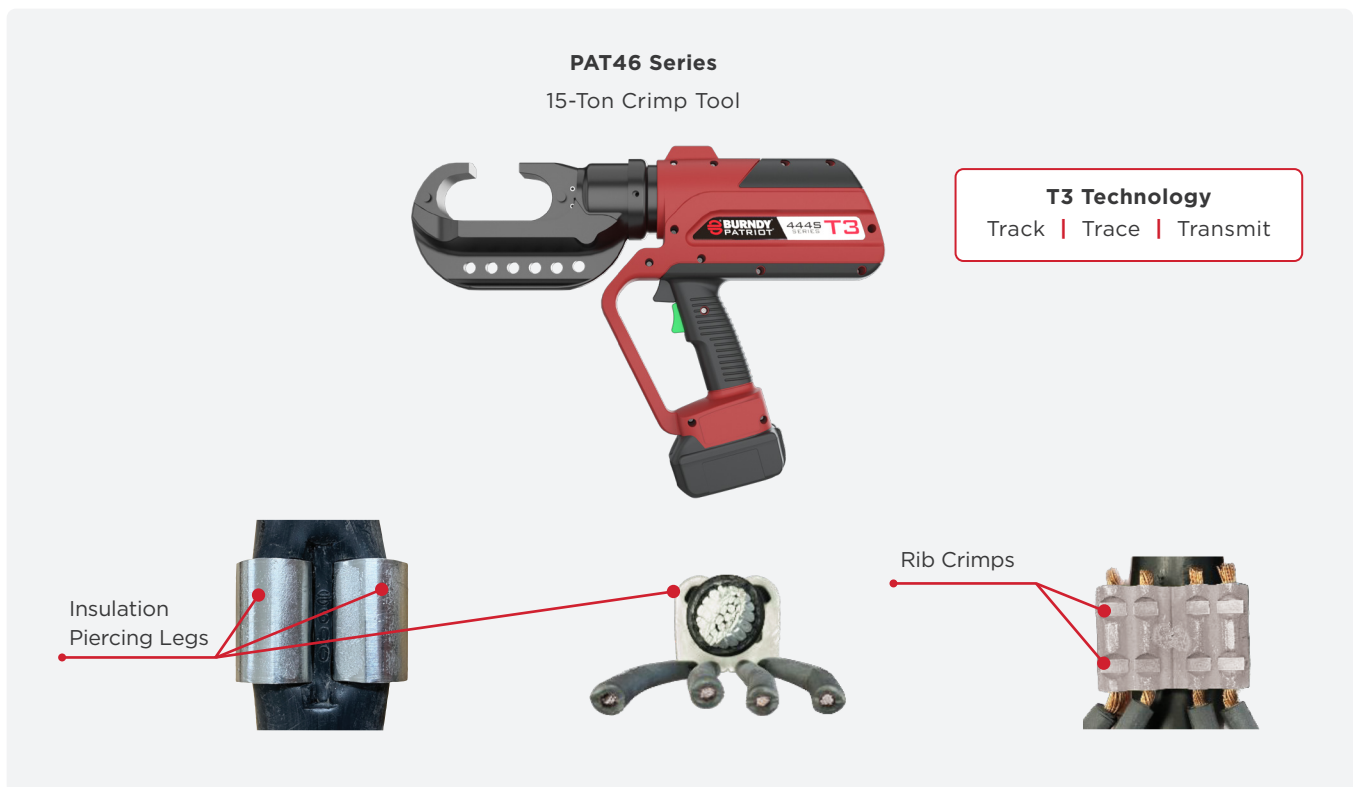

Outer Cover

- 2 Plastic Halves: One half contains strain relief features, while the other half does not. Both halves, when installed, will create a full perimeter raintight seal of the connection.
- Connector Guides: Locate the connector seating in the cover
- Main/Run/Trunk & Tap Grooves: Align the conductors and minimize movement in the cover
- Weep Holes: Designed to drain water at the conductor entry/exit
- Locking Tabs: 8 locking tabs to ensure the cover maintains a tight fit
- Alignment Post / Hole: Male / Female fitting that ensures the cover aligns when installed
- Covers are not reusable, as the gel seal can be disrupted or contaminated during reuse and compromise the watertight seal, which voids any warranty.

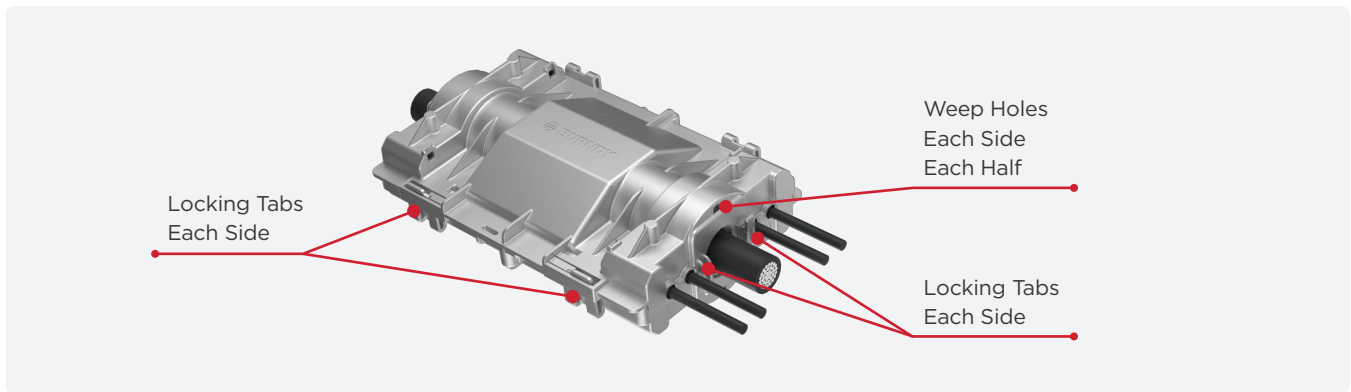

Gel Seal

- Each cover half has a 3-sided gel-fill channel that will create a full perimeter raintight seal when the two halves are installed.

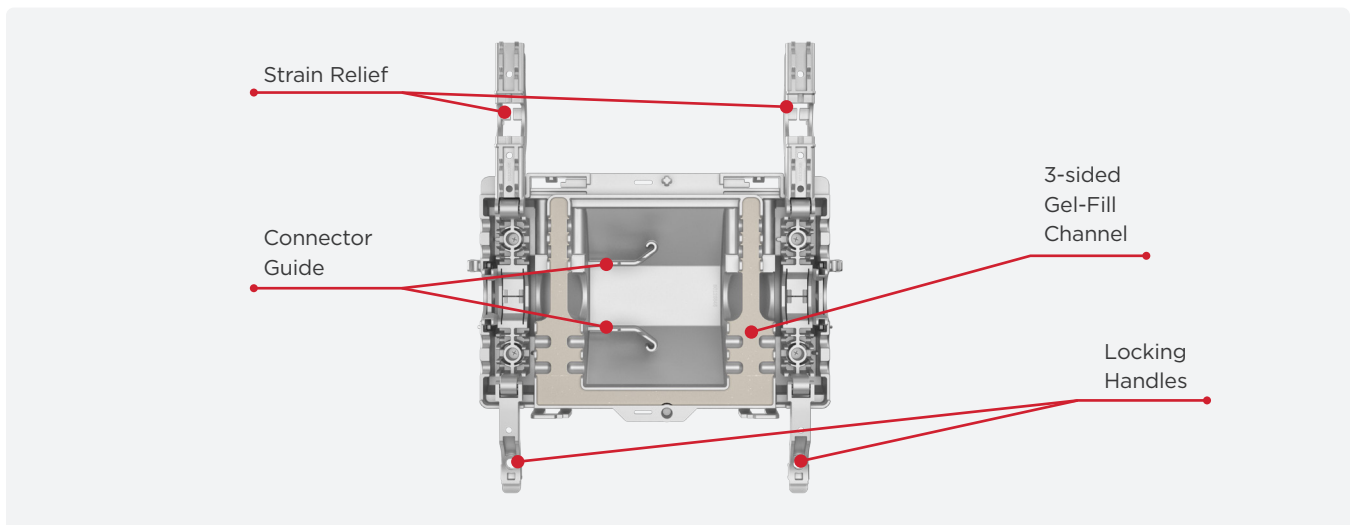

Strain Relief: (both sides/one cover half)

- Main/run/trunk and tap conductor alignment grooves for proper conductor placement.
- Strain relief locking arms provide stress and tension relief at the connection and help constrain the assembly during installation.
- Locking handles prevent unlatching to ensure a secure connection. Locking handles can be released with a screwdriver in the event a cover is required to be removed.

Main/Run/Trunk and Tap Alignment Guides (both sides)

- Ensure the main/run/trunk wire slides into the cover, minimizing movement and gel displacement
- Tap wires may be used in reverse direction inside the cover. If you intend to use this feature, installers are required to use tap ports one (1) and four (4) of the connector.

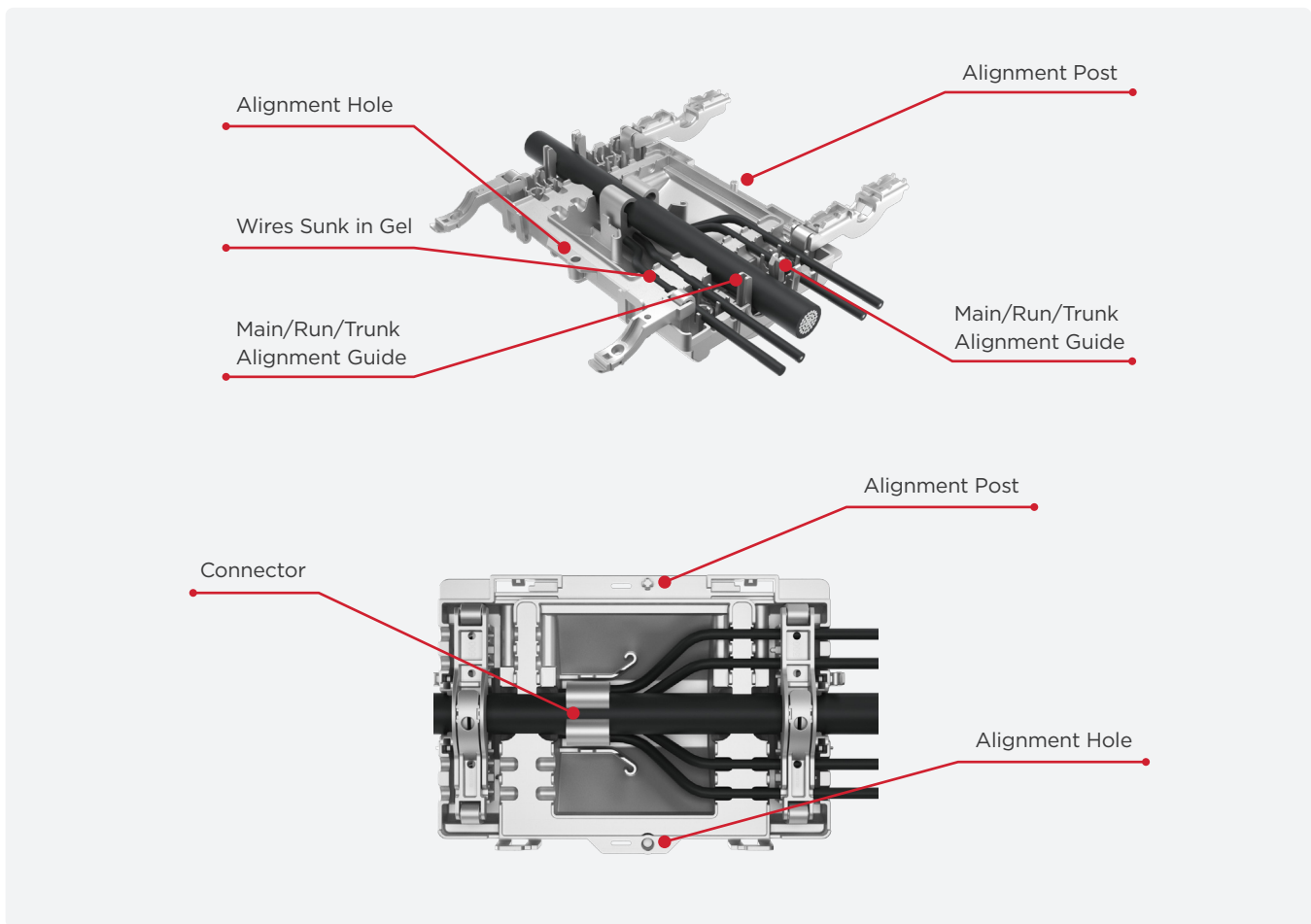

Trust the BURNDY Engineered System

The BURNDY® Engineered System of coordinating dies, connectors and tools are always designed to work together and engineered to meet stringent, accepted quality standards.



Connectors



Dies



Crimp Tools



©2023 Hubbell Incorporated. All rights reserved. Hubbell and the Hubbell logo are registered trademarks or trademarks of Hubbell Inc. All other marks are the property of their respective owners.

Hubbell Canada | 870 Brock Rd S, Pickering, ON L1W 1Z8
hubbell.ca | 800-465-7051

