

INDIRECTTM

Cubic INDIRECTTM



A R C H I T E C T U R A L A R E A L I G H T I N G

“to create, inspire and nurture
EXCELLENCE in each other”



ENERGY EFFICIENCY

The light sources employed in the Indirect family of fixtures are the most efficient sources commercially available today. The reflectors are designed to direct the illumination on the ground with no stray light which translates into wasted energy. The result is more light with less energy consumption.

LIGHT POLLUTION

The Indirect family of fixtures is designated as a cutoff fixture with only 1% of light emitted above 90 degrees horizontal.

LONGEVITY

AAL manufactures all its products to have a life span as long as the building or space they illuminate. The primary material used for all our products is aluminum to resist corrosion and the need for maintenance. Aluminum will not need the periodic refinishing required of steel products that will eventually rust and corrode. All our internal parts and fasteners are made of aluminum or stainless steel. The lamp enclosures are kept dust free and dry to prevent light degradation and maintain a high level of energy efficiency.

SUSTAINABILITY

AAL develops our products with recycling and resource management in mind. We recycle all incoming packaging materials. Our products are shipped in easy to recycle packaging materials. Our state of the art finishing system uses eco friendly cleansing and preparation chemicals that are harmless enough to send to the drain without further processing. Our powder coating process eliminates the release of volatile chemicals into the atmosphere. AAL makes the Indirect, like all AAL products, with renewable materials such as aluminum and stainless steel.

CONTENTS

Elevated Scale	6
Illumination	8
Order Information - Cubic Indirect	10
Specification - Cubic Indirect	12
Installation - Cubic Indirect	13
Order Information - Indirect	14
Specification - Indirect	16
Installation - Indirect	17



AAL is a registered continuing education provider.

The Indirect™ is registered and protected by numerous patents granted by the United States Patent Office. U.S. Patent D468,478; D601, 291

©2009 Architectural Area Lighting.
Printed on recycled paper.



An indirect luminaire that employs the most efficient sources commercially available. The

INDIRECT

family of fixtures is perfect for projects that require a sense of mood as much as a sense of light.



INDA-WMA



The Indirect family features three distinct designs.

The **Cubic Indirect** features an angular design that is a perfect complement to the rectilinear and angular compositions of modern architecture.



Cubic Indirect wall mount
INDC



Cubic Indirect post top
INDC

The **Indirect** features a straight fixed head for a clean look, and an adjustable head for aiming the light when the upper reflector is tilted.



Indirect straight fixed head
INDF



Indirect adjustable head
INDA

All three models feature stainless steel vertical struts and can be configured with a round or square upper reflector.

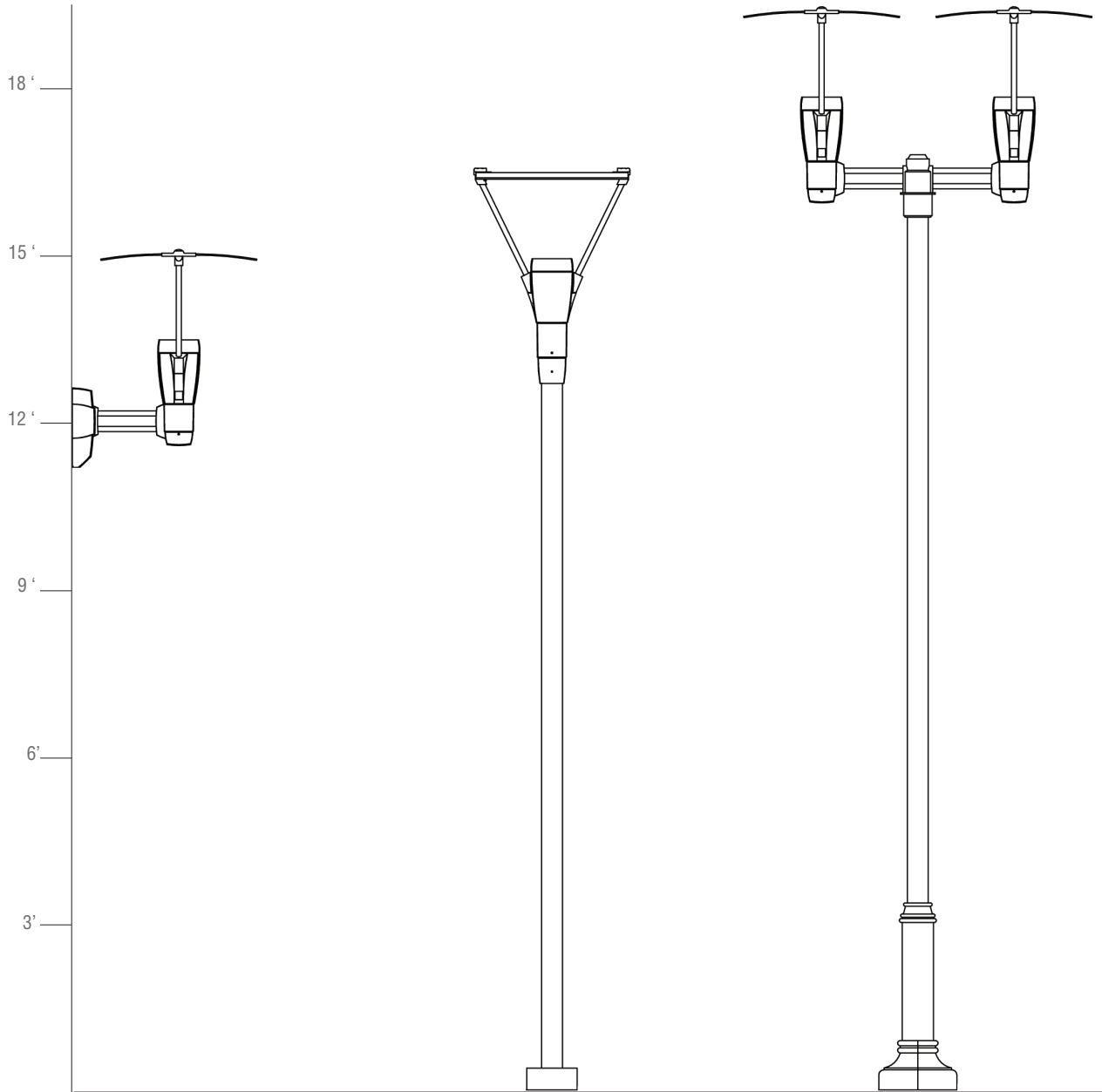

FIXTURE	INDC	INDC	INDC
REFLECTOR	SQ	RD	SQ
MOUNTING	WMA2	PTS4	PMAT2
POLE	-	PS4-4S14	DB6-4R16

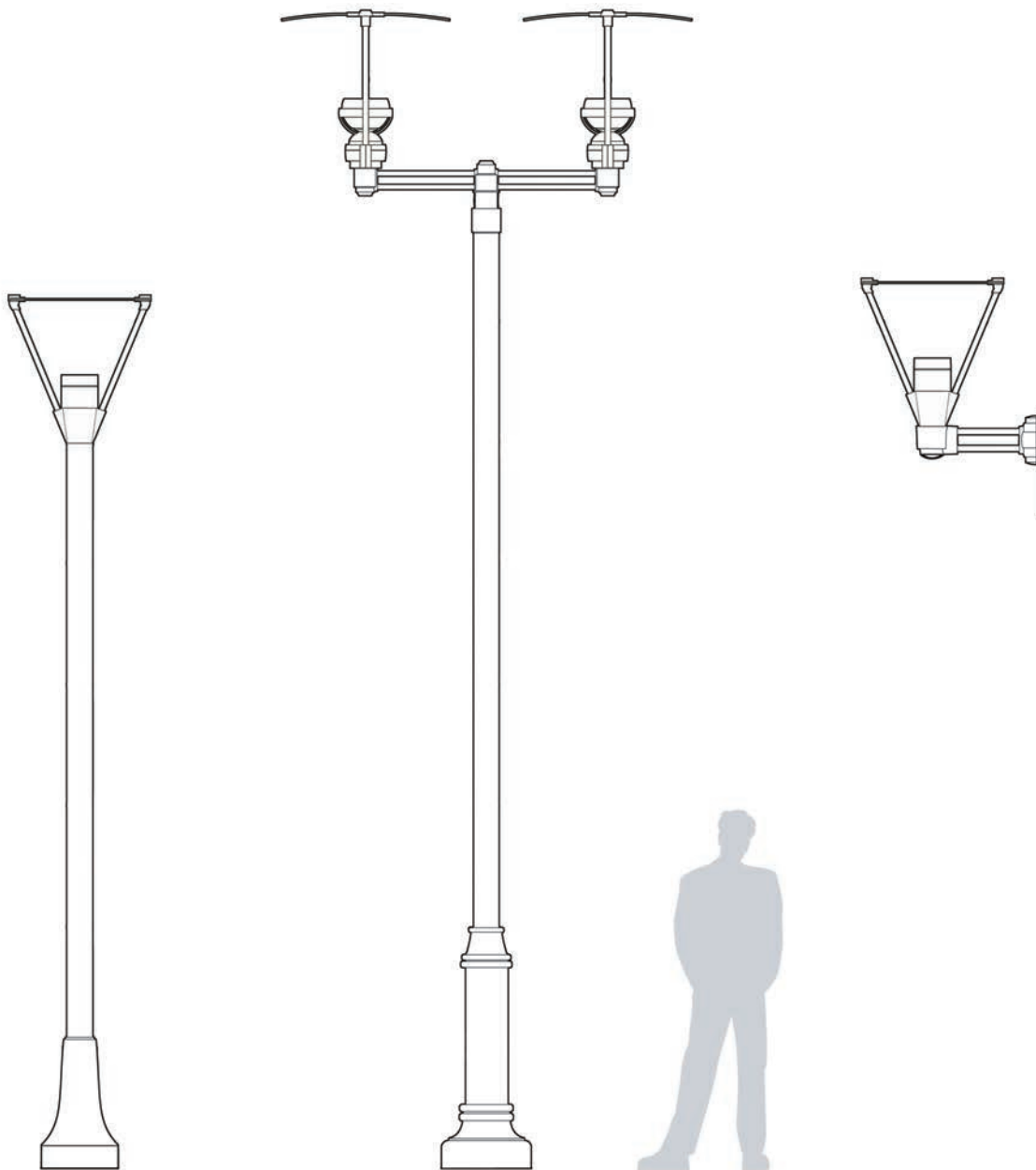

INDF	2-INDA	INDF
SQ	SQ	RD
-	PMAT	WMA
PR5-5R12, BC5-5	DB10-5R16 with AD5	-

Egress

The Cubic Indirect's emergency lighting option, in the wall mount version, illuminates corridors, building entrances and exterior passages for added safety and security. The hidden MR16 lamp, powered as a remote head, is able to be angled 15° in either direction, and provides code-required 1 footcandle path-of-egress illumination, from the building toward the common way.

The Cubic Indirect eliminates the need for secondary fixtures used as emergency egress lighting. All emergency lighting options are installed in the housing, thereby eliminating external compartments or secondary fixtures which result in extra material and labor costs.



Dark Sky Friendly

Other indirect luminaires typically throw 40 to 50 percent of their light output upwards into the sky. The result is poor efficiency as well as light pollution. The Indirect's specially designed lower reflector precisely focuses the light energy onto the upper reflector with virtually no stray uplight. The Indirect and Cubic Indirect emits one percent upward, earning an IES "cutoff luminaire" classification from an independent photometric testing lab.

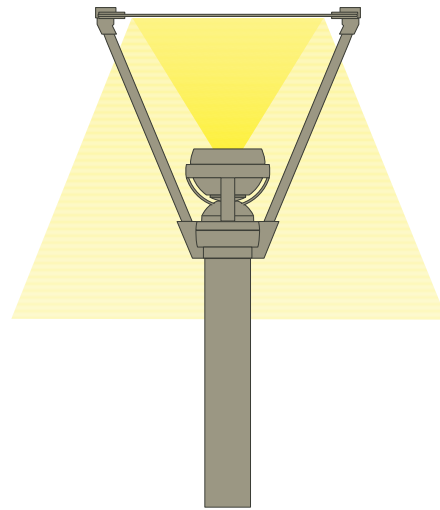

AAL Indirect

AAL Indirect	Others
• 1% uplight	• 40 to 50% uplight
• IES cutoff luminaire	• IES non-cutoff luminaire

Reflector Adjustment

The Indirect and Cubic Indirect upper reflector can be tilted 15 or 30 degrees for an asymmetrical light distribution. The locking clamp design ensures a consistent tilt angle on all fixtures.

The Indirect model INDA has an adjustable lamp head to focus the light beam onto the center of the shade, when the shade is tilted. This improves efficiency and minimizes any stray light beyond the reflector.

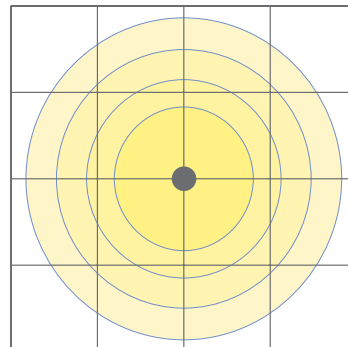

Horizontal position
Type 5 symmetric light pattern

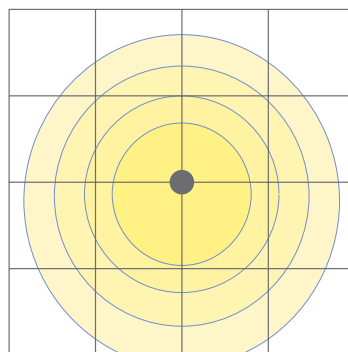

15° tilt position
asymmetric light pattern

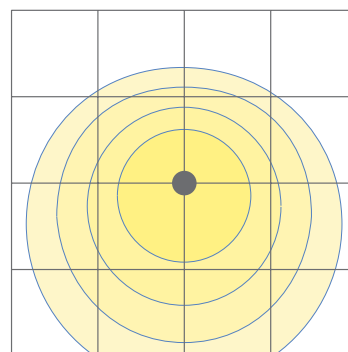

30° tilt position
asymmetric light pattern

1	2	3	4	5	6
FIXTURE	REFLECTOR-UPPER	LAMP/BALLAST	MOUNTING	OPTIONS	COLOR
INDC	RD	CF	WMA2	CDC	BLK

1. FIXTURE

INDC Square straight, fixed head. Post top mount.
Slips over a 2 3/8 inch O.D. tenon
(5 in/127 mm square pole) or a 4 in/100 mm square pole.

2. REFLECTOR - UPPER

RD 30 inch round upper reflector
SQ 30 inch square upper reflector

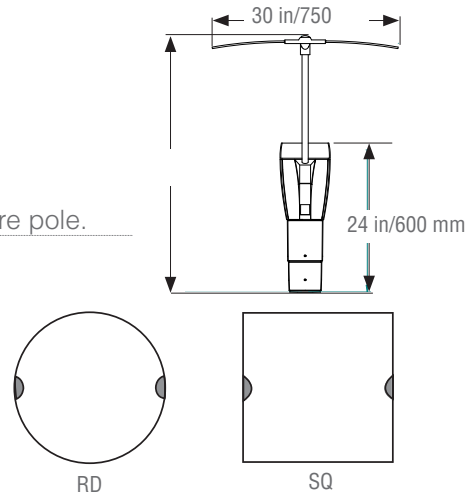

3. LAMP/BALLAST

CF	Electronic 120 thru 277 volt ballast. -18°C starting temp. Use 4-pin 26, 32 or 42 watt lamp.
70MH	70 watt metal halide 120/208/240/277 volt ballast. Use medium base, ED-17 lamp.
70MHEB	70 watt electronic metal halide 120 thru 277 volt ballast. Use medium base, ED-17 lamp.
70MHT6	70 watt metal halide 120/277/347 volt ballast. Use G12 base, T6 ceramic lamp.
70MHT6EB	70 watt electronic metal halide 120 thru 277 volt ballast. Use G12 base, T6 lamp.
100MH	100 watt metal halide 120/208/240/277 volt ballast. Use medium base, ED-17 lamp.
150PSMH	Pulse start 150 watt metal halide 120/208/240/277 volt ballast. Use medium base ED-17 lamp.
150PSMHT6	Pulse start 150 watt metal halide 120/208/240/277 volt ballast. Use G12 base, T6 ceramic lamp.
70R111	70 watt metal halide 120/277 volt ballast. Use R111 lamp.
70R111EB	70 watt electronic metal halide 120/277 volt ballast. Use R111 lamp.
30LED-WW	30 light emitting diode array (33 watt). Warm white (3000K). 120 thru 277 volt.
30LED-NW	30 light emitting diode array (33 watt). Neutral white (4000K). 120 thru 277 volt.
30LED-BW	30 light emitting diode array (33 watt). Bright white (5000K). 120 thru 277 volt.

All ballasts are factory wired for 277 volts. Lamps not included

1	2	3	4	5	6
FIXTURE	REFLECTOR-UPPER	LAMP/BALLAST	MOUNTING	OPTIONS	COLOR
INDC	RD	CF	WMA2	CDC	BLK

4. MOUNTING – Must choose one

WMA2	Wall mounted arm, 10 lbs. Features built in MR16 egress (50 watt).
WMA2-NEG	Wall mounted arm, 10 lbs. No egress lamp. Blocked opening.
PMAT2	Twin pole mount arm, slips over a 4 in/100 mm O.D. pole or tenon.
PTS5	Post top mount slips over a 2 3/8 inch O.D. round tenon (5 in/127 mm square pole)
PTS4	Post top mount slips over a 4 in/100 mm square pole

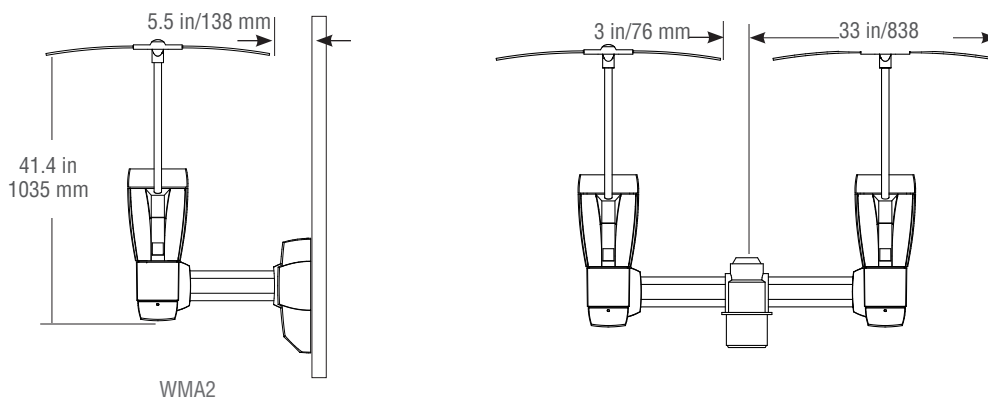

5. OPTIONS

CDC	Center deflector cone for round reflector. Provides a wider light distribution.
SR	Two aluminum rings attached to the fixture. Factory installed.
CFH	Color filter holder attached to the fixture includes solid rings. Factory installed.
LAMP R111	70 watt metal halide R111 reflector lamp.

6. COLOR

All standard and premium AAL colors available.
 For RAL and custom colors, please submit a 4-digit RAL number or color chip for custom colors.

specifications — cubic indirect

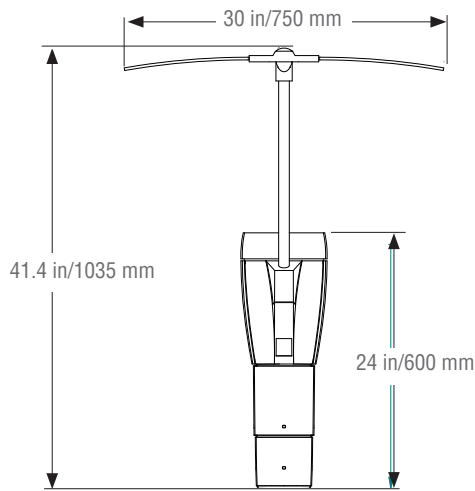

WT: 45.9 lbs.

EPA:	INDC-SQ Sail:	INDC-RD Sail:
	0° = 1.70	0° = 1.46
	15° = 3.27	15° = 2.89
	30° = 5.01	30° = 4.28

UPPER REFLECTOR

The upper reflector shall be light weight aluminum composite. The reflector shall be finished in a white, fluoropolymer finish. The reflector shall be attached to the cast aluminum pivot joints and secured with four stainless steel bolts. Two cast aluminum, adjustable knuckles shall connect the reflector assembly to the vertical, stainless steel struts. The struts are #316 stainless steel with a minimum .075 inch wall thickness. The struts shall be clamped in place with 5/16-18 set screws for attachment to the upper reflector and the lamp module.

LAMP MODULE

The reflector shall be enclosed in cast aluminum housing. The front cover is secured with four cap screws for re-lamping and internal access. The top glass element is clear, tempered glass. The top cover and electrical module are sealed with memory retentive, molded silicone gaskets. The parabolic reflector shall be pre-focused to illuminate the upper reflector with no stray light beyond the reflector. All internal and external hardware is stainless steel.

HOUSING

The post top model shall slip over a 2 3/8 inch O.D. tenon (5 in/127 mm square pole) or 4 in/100 mm square pole.

SAFETY

The wall mounted luminaire (WMA2) includes an integral secondary source to provide code-required 1 footcandle emergency path-of-egress illumination from building to the public way. The hidden MR16 lamp, powered as a remote head, is able to be angled up to 15° in either direction.

ELECTRICAL MODULE

The ballast is mounted on a pre-wired plate with a quick disconnect plug. Magnetic metal halide ballasts are high power factor, rated for -30°C starting. Electronic metal halide ballasts are rated for -30°C starting, sound rating A, 120 thru 277 volt. Sockets are pulse rated porcelain for medium base ED-17; bi-pin, G12 for T-6 lamps; GX8.5 for R111. The compact fluorescent shall have an electronic transformer, 120 thru 277 volt.

FINISH

Fixture finish consists of a five stage pretreatment regimen with a polymer primer sealer, oven dry off and top coated with a thermoset super TGIC polyester powder coat finish. The finish shall meet the AAMA 605.2 performance specification which includes passing a 3000 hour salt spray test for corrosion resistance. The reflector shall be painted white. The lens frame shall be painted black to further control any up light. The vertical struts are stainless steel. All other fixture parts shall be finished in the same specified color.

CERTIFICATION

The fixture shall be listed with ETL and U.L. for outdoor, wet location use, UL1598 and Canadian CSA Std. C22.2 NO.250. IP=66

WARRANTY

Fixture is warranted for three years. Ballast components carry the ballast manufacturer's limited warranty. Any unauthorized return, repair, replacement or modification of the Product(s) shall void this warranty. This warranty applies only to the use of the Product(s) as intended by AAL and does not cover any misapplication or misuse of said Product(s), or installation in hazardous or corrosive environments. Contact AAL for complete warranty language, exceptions, and limitations.

Note: The Cubic Indirect is not suitable for high wind loading areas. Do not install these products between buildings or other unusual zones where wind may exceed normal loads.



Tool-less access to integral ballast assembly

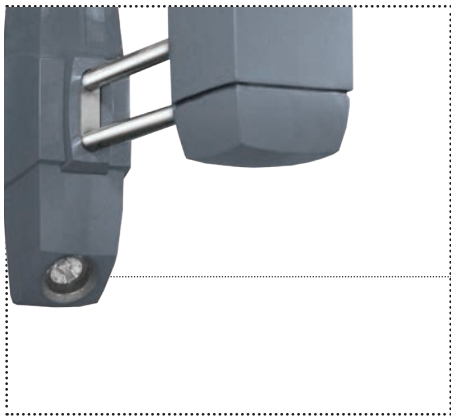

Hidden MR16 lamp in wall mount (WMA2) provides code-required 1 foot candle emergency path-of-egress illumination



Lens frame painted black to further control uplight

1	2	3	4	5	6
FIXTURE	REFLECTOR-UPPER	LAMP/BALLAST	MOUNTING	OPTIONS	COLOR
INDF	RD	70MH	WMA	CDC	BLK

1. FIXTURE

- INDA Adjustable head. Slips over a 5 in/127 mm O.D. pole.
- INDF Fixed head. Slips over a 5 in/127 mm O.D. pole.

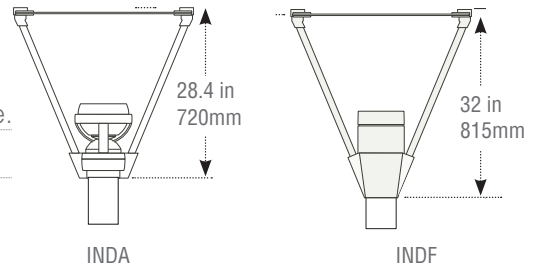

2. REFLECTOR - UPPER

- RD 30 inch round upper reflector
- SQ 30 inch square upper reflector

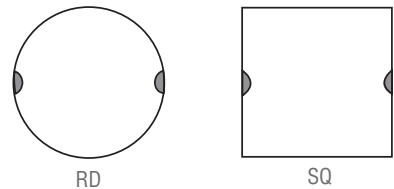

3. LAMP/BALLAST

- CF Electronic 120 thru 277 volt ballast. -18°C starting temp. Use 4-pin 26, 32 or 42 watt lamp. **For INDA - 26 watts only.**
 - 70MH 70 watt metal halide 120/208/240/277 volt ballast. Use medium base, ED-17 lamp. **For INDF model only.**
 - 70MHEB 70 watt electronic metal halide 120 thru 277 volt ballast. Use medium base, ED-17 lamp. **For INDF model only.**
 - 70MHT6 70 watt metal halide 120/277/347 volt ballast. Use G12 base, T-6 ceramic lamp.
 - 70MHT6EB 70 watt electronic metal halide 120 thru 277 volt ballast. Use G12 base, T-6 ceramic lamp.
 - 100MH 100 watt metal halide 120/208/240/277 volt ballast. Use medium base, ED-17 lamp. **For INDF model only.**
 - 150PSMH Pulse start 150 watt metal halide 120/208/240/277 volt ballast. Use medium base ED-17 lamp. **For INDF model only.**
 - 150PSMHT6 Pulse start 150 watt metal halide 120/208/240/277 volt ballast. Use G12 base, T6 lamp.
 - 30LED-WW 30 light emitting diode array (33 watt). Warm white (3000K). 120 thru 277 volt.
 - 30LED-NW 30 light emitting diode array (33 watt). Nutral white (4000K). 120 thru 277 volt.
 - 30LED-BW 30 light emitting diode array (33 watt). Bright white (5000K). 120 thru 277 volt.
- All ballasts are factory wired for 277 volts. Lamps not included*

1	2	3	4	5	6
FIXTURE	REFLECTOR-UPPER	LAMP/BALLAST	MOUNTING	OPTIONS	COLOR
INDF	RD	70MH	WMA	CDC	BLK

4. MOUNTING

WMA Wall mounted arm, 10 lbs. EPA: 0.68

PMAT Twin pole mount arm, slips over a 4 in/100mm O.D. pole or tenon, 14 lbs. EPA: 0.83

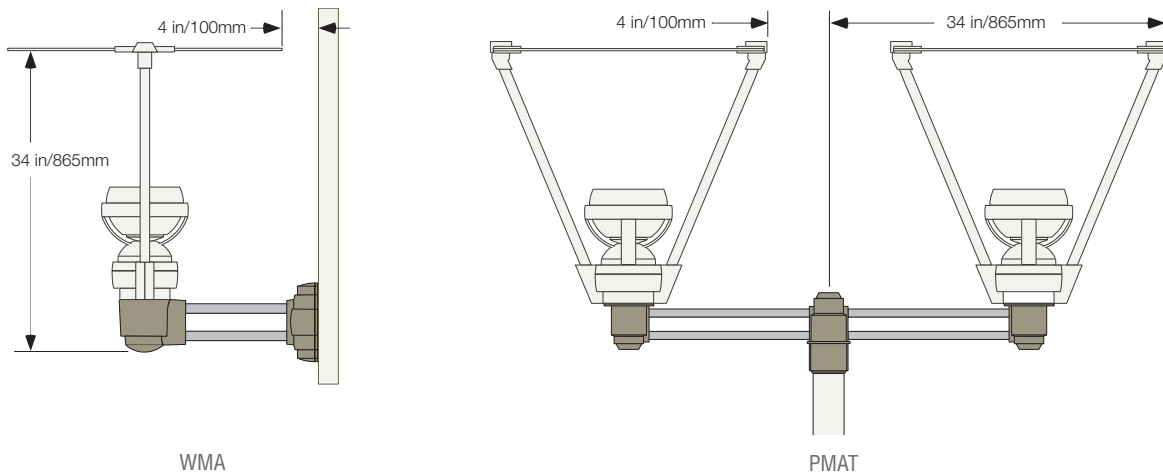

5. OPTIONS

CDC Center deflector cone for round reflector. Provides a wider light distribution.

SR Two aluminum rings attached to the fixture. Factory installed. **INDA only.**

CFH Color filter holder attached to the fixture. Factory installed. **INDA only.**

LAMP70 Philips® 70 watt clear T-6 ceramic metal halide lamp, CDM70/T6/830

LAMP150 Philips® 150 watt clear T-6 ceramic metal halide lamp, CDM70/T6/830

AD5 Cast aluminum adapter for the PMAT arm to slip over a 5 in/127 O.D. mm pole

6. COLOR

All standard and premium AAL colors available.

For RAL and custom colors, please submit a 4-digit RAL number or color chip for custom colors.

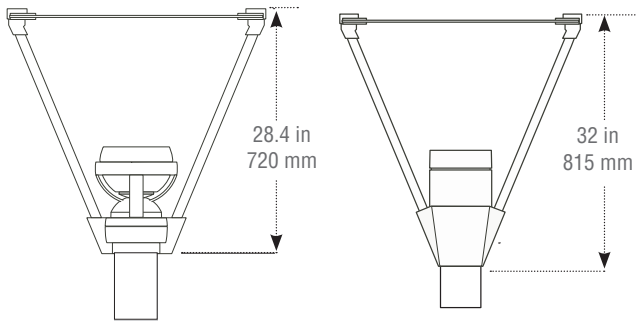

UPPER REFLECTOR

The upper reflector shall be a light weight aluminum composite. The reflector shall be finished in a white, fluoropolymer finish. The reflector shall be attached to the cast aluminum pivot joints and secured with four stainless steel bolts. Two cast aluminum, adjustable knuckles shall connect the reflector assembly to the vertical, stainless steel struts. The struts are #304 stainless steel with a minimum .250" wall thickness. The struts shall have threaded connections for attachment to the upper reflector and the lamp module.

LAMP MODULE

The reflector shall be enclosed in cast aluminum housing. The front cover is secured with four cap screws for relamping and internal access. The front glass element is clear, tempered glass. The front cover and electrical module are sealed with memory retentive, molded silicone gaskets.

The parabolic reflector shall be prefocused to illuminate the upper reflector with no stray light beyond the reflector. The fixture shall be IES rated as a cutoff. The INDA model lamp module swivels, to center the beam on a tilted reflector, by loosening two stainless steel cap screws. All internal and external hardware is stainless steel.

HOUSING

The INDA and INDF post top models shall slip over a 5 in/127 mm O.D. pole.

ELECTRICAL MODULE

The ballast is mounted on a prewired plate with a quick disconnect plug. Magnetic metal halide ballasts are high power factor, rated for -30°C starting. Electronic metal halide ballasts are rated for -30°C starting, sound rating A, 120 thru 277 volt. Sockets are pulse rated porcelain, bi-pin, G12 for T-6 lamps. A porcelain screw base for the mini-cand T-4 halogen lamp. The compact fluorescent shall have an electronic transformer, 120 thru 277 volt.

FINISH

Fixture finish consists of a five stage pretreatment regimen with a polymer primer sealer, oven dry off and top coated with a thermoset super TGIC polyester powder coat finish. The finish shall meet the AAMA 605.2 performance specification which includes passing a 3000 hour salt spray test for corrosion resistance.

The reflector shall be painted white. The vertical struts are stainless steel. All other fixture parts shall be finished in the same specified color.

CERTIFICATION

The fixture shall be listed with ETL and U.L. for outdoor, wet location use, UL1598 and Canadian CSA Std. C22.2 NO.250. IP=66

EPA: INDA or INDF

round upper reflector/ 0° tilt: 3.65

square upper reflector/ 0° tilt: 4.40

round upper reflector/ 30° tilt: 6.52

square upper reflector/ 30° tilt: 6.62

WARRANTY

Fixture is warranted for three years. Ballast components carry the ballast manufacturer's limited warranty. Any unauthorized return, repair, replacement or modification of the Product(s) shall void this warranty. This warranty applies only to the use of the Product(s) as intended by AAL and does not cover any misapplication or misuse of said Product(s), or installation in hazardous or corrosive environments. Contact AAL for complete warranty language, exceptions, and limitations.

Note: The Indirect is not suitable for high wind loading areas. Do not install these products between buildings or other unusual zones where wind may exceed normal loads.



Lightweight aluminum composite reflector reduces pole stress

Reflector tilts and locks at 15° or 30°

Adjustable head (INDA) tilts to center the beam onto the reflector. The parabolic reflector focuses the light beam into the upper reflector for maximum efficiency

Also available with fixed head for streamlined look

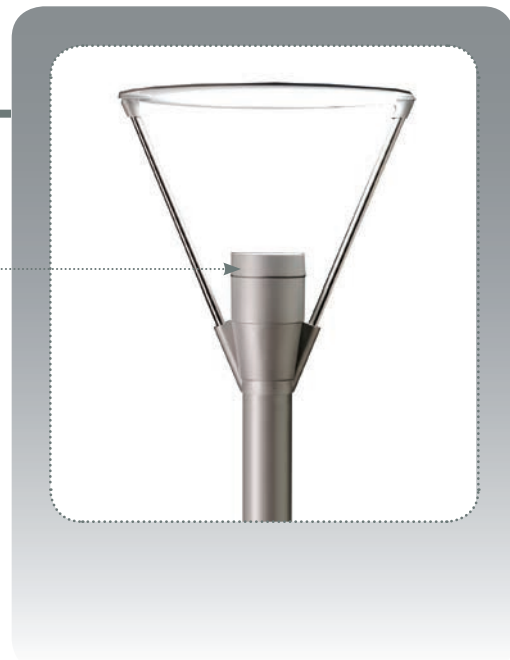

INDF



INDA



INDC-PTS4

INDA



INDA



INDIRECT™ Cubic INDIRECT™



Architectural Area Lighting
17760 Rowland Street
City of Industry, CA 91748

T 626.968.5666 | F 626.369.2695 | www.aal.net/aal/indindc110.html