

## NEW – WGM/WGL full cut-off wallpacks

Hubbell Outdoor Lighting's new WGM/WGL are designed for entry and perimeter lighting with typical mounting heights of 10'-15' for the WGM and 15'-25' for the WGL. Use where full cut-off light control is required. Typical applications are commercial, office, warehouse and locations.

### Key Features & Benefits

- Two sizes for proper architectural scale
  - WGM – 10-15 ft typical mounting heights
  - WGL – 15-25 ft typical mounting heights
- No uplight – Neighbor friendly
- Die-cast aluminum construction for durability, rigid mounting and excellent heat dissipation for long life
- Clear, tempered, impact resistant glass lens
- 1/2" hubs – top and side locations for surface conduit or photocontrol
- Energy efficient pulse start metal halide, HPS and CFL sources
- WGM-84F-MS42 motion sensor energy saver – illuminates one 42w lamp standard with motion sensor control of second lamp. 50% energy savings when activity is not present. Can be field wired to total sensor control if desired
- Dark Bronze powder coat finish protects housing and provides lasting appearance
- UL1598 listed for use in wet locations



WGM PHOTOMETRIC PERFORMANCE

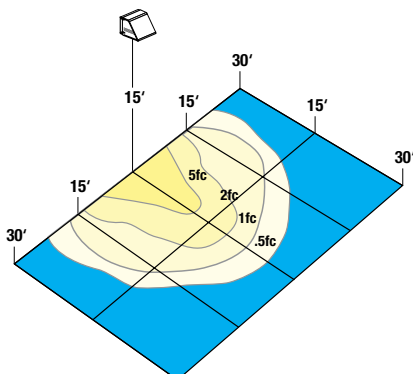

WGL PHOTOMETRIC PERFORMANCE

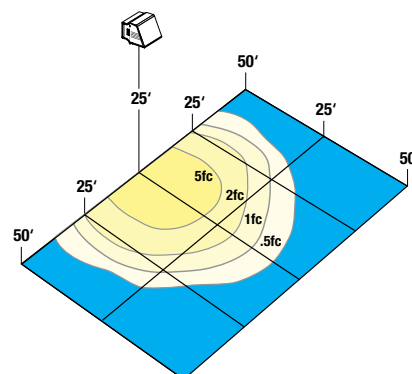

ORDERING INFORMATION ON REVERSE SIDE

**ORDERING INFORMATION**



CATALOG NUMBER	WATTAGE/SOURCE	VOLTAGE	FINISH	LAMP	WEIGHT LBS. (KG)
<b>WGM – Medium Base or CFL</b>					
<b>WGM-100P</b>	100w PSMH	120, 208, 240, 277V	Bronze	ED17	18 (8.2)
<b>WGM-150P</b>	150w PSMH	120, 208, 240, 277V	Bronze	ED17	19 (8.6)
<b>WGM-150S</b>	150w HPS	120, 208, 240, 277V	Bronze	ED17	18 (8.2)
<b>WGM-84F</b>	2x42w CFL	120-277V	Bronze	3u-4 Pin	16 (7.3)
<b>WGM-84F-MS42<sup>1</sup></b>	2x42w CFL	120V	Bronze	3u-4 Pin	16 (7.3)

<sup>1</sup> CFL lamps are 3500K, sensor has adjustable time and sensitivity controls

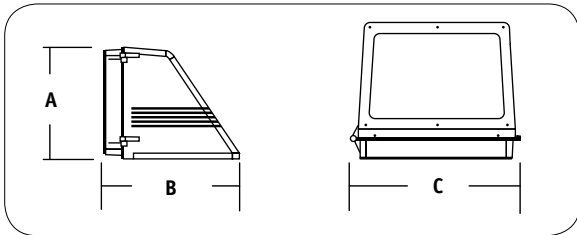

A	B	C
9.25"	11.4"	14.2"
235 mm	290 mm	361 mm



CATALOG NUMBER	WATTAGE/SOURCE	VOLTAGE	FINISH	LAMP	WEIGHT LBS. (KG)
<b>WGM – Medium Base or CFL</b>					
<b>WGL-250P</b>	250w PSMH	120, 208, 240, 277V	Bronze	ED28	27 (12.3)
<b>WGL-320P</b>	320w PSMH	120, 208, 240, 277V	Bronze	ED28	28 (12.7)
<b>WGL-250S</b>	250w HPS	120, 208, 240, 277V	Bronze	ED18	32 (14.5)
<b>WGL-400S</b>	400w HPS	120, 208, 240, 277V	Bronze	ED18	32 (14.5)

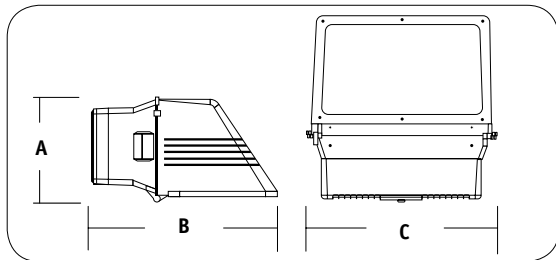

A	B	C
9.84"	17.2"	18"
250 mm	438 mm	456 mm