

Veri*Lite™ DEADEND & SUSPENSION INSULATORS

for 15-69kV Applications

Experience & Reliability

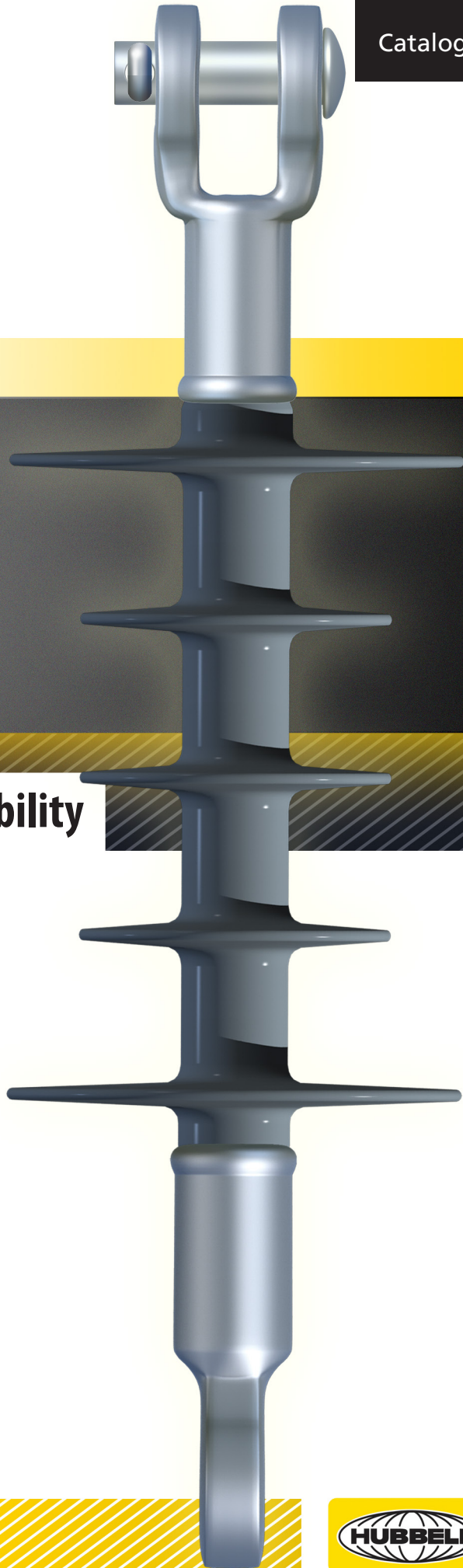

Warranty—Material

Hubbell Power Systems, Inc. warrants all products sold by it to be merchantable (as such term is defined in the Uniform Commercial Code) and to be free from defects in material and workmanship. Buyer must notify the Company promptly of any claim under this warranty. The Buyer's exclusive remedy for breach of this warranty shall be the repair or replacement, F.O.B. factory, at the Company's option, of any product defective under the warranty which is returned to the Company within one year from the date of shipment. NO OTHER WARRANTY, WHETHER EXPRESS OR ARISING BY OPERATION OF LAW, COURSE OF DEALING, USAGE OF TRADE OR OTHERWISE IMPLIED, SHALL EXIST IN CONNECTION WITH THE COMPANY'S PRODUCTS OR ANY SALE OR USE THEREOF. The Company shall in no event be liable for any loss of profits or any consequential or special damages incurred by Buyer. The Company's warranty shall run only to the first Buyer of a product from the Company, from the Company's distributor, or from an original equipment manufacturer reselling the Company's

product, and is non-assignable and non-transferable and shall be of no force and effect if asserted by any person other than such first Buyer. This warranty applies only to the use of the product as intended by Seller and does not cover any misapplication or misuse of said product.

Warranty—Application

Hubbell Power Systems, Inc. does not warrant the accuracy of and results from product or system performance recommendations resulting from any engineering analysis or study. This applies regardless of whether a charge is made for the recommendation, or if it is provided free of charge.

Responsibility for selection of the proper product or application rests solely with the purchaser. In the event of errors or inaccuracies determined to be caused by Hubbell Power Systems, Inc., its liability will be limited to the re-performance of any such analysis or study.



Deadend & Suspension Insulators

INSIDE.....	PAGE
Distinguished by Design	5
Product Performance	6
Polymer Design Tests.....	7
PDI Mechanical and Electrical Characteristics.....	8
VLS Mechanical and Electrical Characteristics	10
End Fitting Details.....	12

Experience



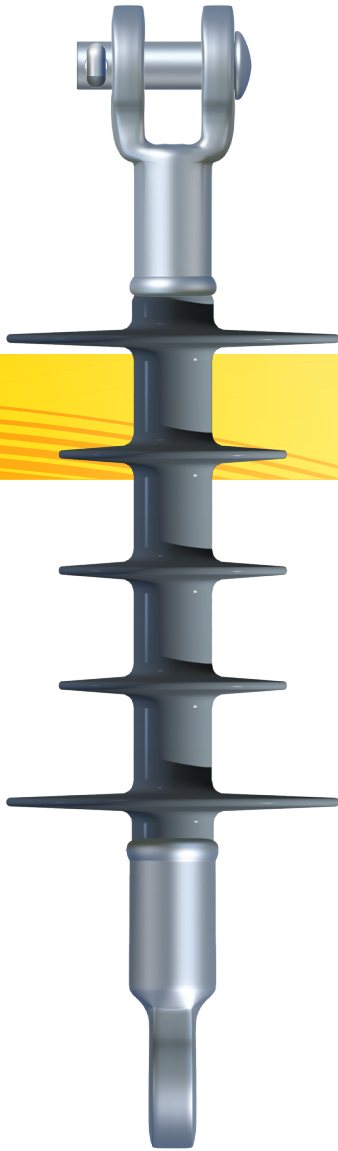

Hubbell has been leading the way with polymer insulators under the distinguished Ohio Brass name since 1976. Veri*Lite distribution insulators embody the latest in polymer design and manufacturing features.

Our Veri*Lite insulators are backed by thorough testing and research to provide our customers with high performance products. More than 30 million distribution deadend



and suspension insulators have been put into service around the world. Hubbell is dedicated to providing superior products and service to the power industry.

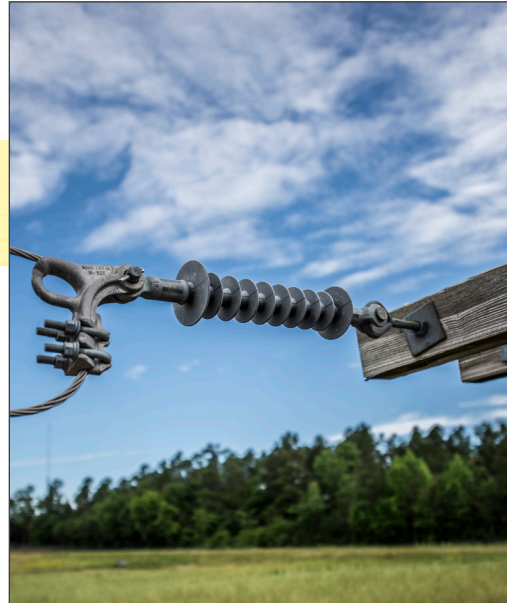

Performance

Distinguished by Design

Porcelain Bell Equivalents — The full line of Veri*Lite Suspension and Deadend insulators are direct equivalents to 5 ¾ inch x 10 inch and 4 ¼ inch x 6 ¼ inch porcelain bells, respectively. Please refer to the Electrical Characteristics table for the number of bell equivalents, on pages 9 and 11.

DS Class Ratings — The Polymer Deadend Insulator (PDI) product line has an offering for several DS class ratings, in accordance with ANSI C29.13 and CSA C411.5-10 standards. Please refer to the Electrical Characteristics table on page 9 for the appropriate insulator class rating.

Rod — Veri*Lite Insulators are produced from the highest quality materials. Strands in the fiberglass rod are aligned for maximum tensile strength, and the rod is filled 70 percent, by weight, with electrical corrosion resistant fibers and epoxy resin.

End Fittings — Ferrous end fittings are crimped directly to the fiberglass rod by a process originated by Ohio Brass and later adopted by other manufacturers. The crimp requires no intermovement of the parts to achieve high strength, nor does it introduce potting compounds or adhesives.

Weathersheds — Veri*Lite Insulators are manufactured with ESP™ rubber, the same proven material used in PDV arresters and Hi*Lite Insulators. ESP™ is a polymer compound made by alloying silicone and EPDM rubber. This alloy offers the desired toughness and resistance to tracking of the original EPR, along with the hydrophobic characteristics derived from low molecular weight silicone oils. Veri*Lite PDI's are also available in silicone rubber with Ohio Brass proprietary compound, the same proven material used in Quadri*Sil Transmission Insulators.

Testing You Can Count On... Hubbell's state-of-the-art electrical and mechanical testing facilities are capable of performing ANSI, IEC, CSA, and other industry required tests.

For further information on our polymers, ask your Hubbell Ohio Brass representative for the publication "Polymer Materials for Insulator Weathersheds", EU1264 – H.



Product Performance

Leakage Distance — Veri*Lite Insulators feature high leakage distance for optimum contamination performance.

Cleaning — Washing of the Veri*Lite suspension and dead-end insulators may be required based on the contamination level of the installation location. In the event that washing is required, the procedures outlined in Section IX of the "IEEE GUIDE FOR INSULATOR CLEANING," IEEE STD 957-2005 are generally applicable.

Standards — Veri*Lite suspension and deadend insulators meet the latest ANSI/IEEE-1024, CSA C411.5-10, and IEC-61109 standards. Hubbell's manufacturing facilities have implemented a quality system in accordance with ISO 9001:2008.

Mechanical Ratings — The Specified Mechanical Load (SML) rating for all Veri*Lite suspension and deadend insulators is 15,000 lbs. The Routine Test Load (RTL) rating for these insulators is 50% of the SML rating.

All Veri*Lite suspension and deadend insulators are proof tested to 10,000 lbs in tension prior to shipment from the factory. This test load exceeds the RTL rating of the insulator to ensure the quality of our product.

Markings — Markings for Veri*Lite suspension and deadend insulators are permanently embossed into the end fittings and polymer housing. Markings include SML rating, date of manufacture, DS rating in accordance with ANSI C29.13 and CSA C411.5-10 standards, and Ohio Brass identification.

Packaging — The standard packaging of Veri*Lite suspension and deadend insulators is in boxes stacked on pallets. The quantity per box and pallet vary based on the catalog number. Please refer to the Mechanical characteristics table in this catalog for the standard packing quantities.



Polymer Design Tests

The following must be performed to certify a material for use in production.

Tracking test: Performed on a sample of material inclined at 15° and electrodes positioned 35 mm apart. Samples are sprayed with a conductive solution (400Ωcm) and energized at 10kV. The cycle is repeated every 90 seconds. The sample passes if there is:

1. No carbonization or tracking.
2. No erosion through sample.
3. No leakage current flow at the end of 90 seconds.

The sample must withstand 20,000 test cycles.

Ultraviolet Test: Samples of the rubber must be tested in a QUV tester or equivalent cyclic weatherometer. The samples are exposed to high ultraviolet radiation and high humidity without cracking, checking, or becoming hydrophilic. The sample is judged to have passed this test if it exceeds 8,000 hours of exposure without damage.

Corona Cutting: Samples 5 cm by 7 cm are subjected to mechanical stress of 300,000 microstrain by bending samples over a grounded electrode. A needle-like electrode is placed 1 mm from the surface of the sample and energized at 12 kV in a controlled humidity chamber. The sample is judged to have passed this test if there is no splitting or cutting during 1,000 hours of exposure to these test conditions.

Oxidative Stability: Samples of the polymer compound are tested using differential scanning calorimetry. Samples are heated rapidly in a nitrogen atmosphere to the test temperature of 200°C. The atmosphere is then changed to air, and the temperature is maintained until the antioxidant is consumed, as measured by an exothermic chemical reaction. The time for this reaction to occur must exceed 300 minutes.

Tear Strength: Rubber test slabs are prepared in accordance with ASTM Standards and are tested to determine tear strength of the material. The minimum acceptable tear strength is 150 lb/in.

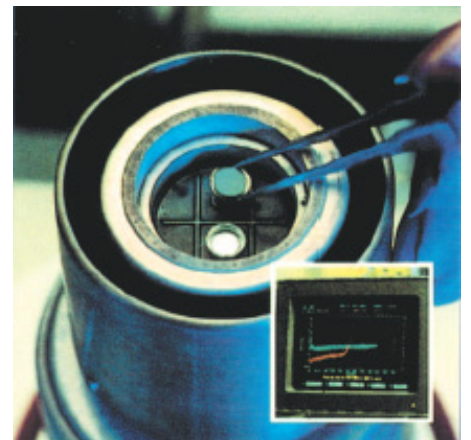

PDI Mechanical Characteristics

0.625" (16mm) Diameter Rod Deadend Insulators

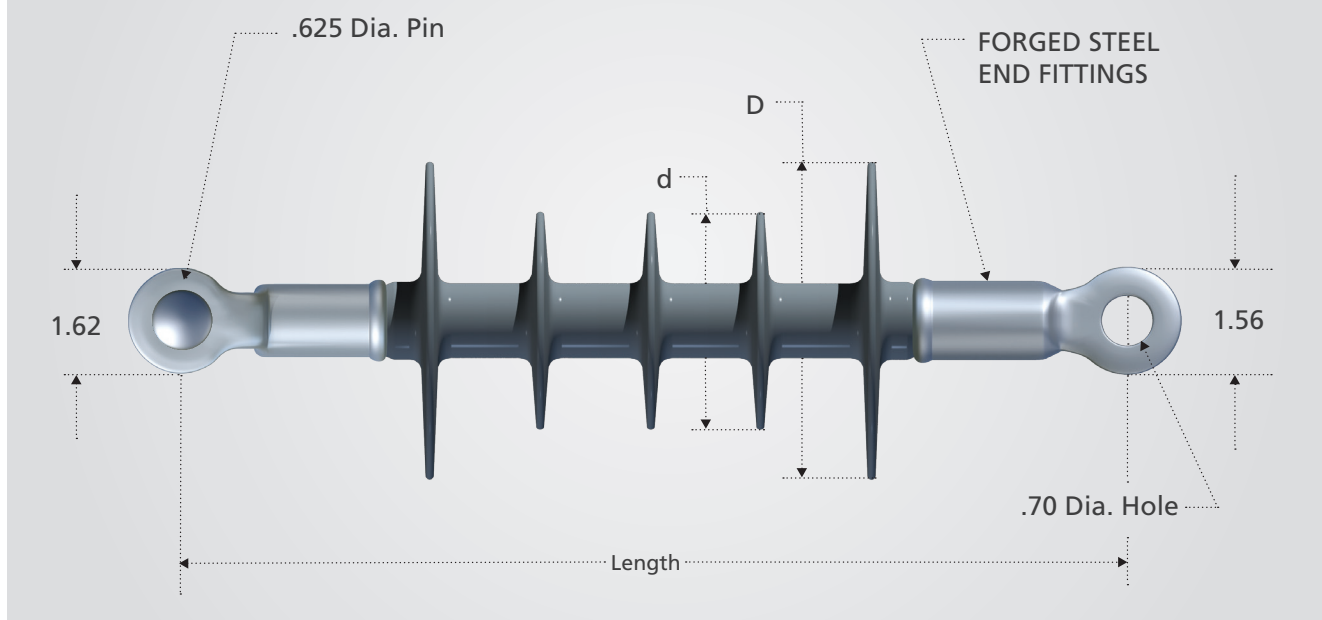

Mechanical Characteristics

Catalog Number	No. of Sheds	Length Inches (mm)	Diameter Inches (mm)		Net Wt. pounds (kg)	Standard Package Qty		Torsion ft-lb (N-m)	² SML pounds (kN)	³ RTL pounds (kN)	⁴ Proof pounds (kN)
			D	d		Box	Pallet				
4010150215	5	12.50 (318)	3.9 (99)	2.7 (69)	2.3 (1.0)	15	540	35 (47)	15,000 (70)	7,500 (35)	10,000 (44.5)
4010280215	10	17.50 (445)	3.3 (84)	2.4 (61)	2.5 (1.1)	15	360	35 (47)	15,000 (70)	7,500 (35)	10,000 (44.5)
4010250215	10	18.75 (475)	3.8 (97)	2.8 (71)	2.7 (1.2)	15	360	35 (47)	15,000 (70)	7,500 (35)	10,000 (44.5)
4010350215	8	25.00 (635)	3.0 (76)		2.8 (1.3)	15	300	35 (47)	15,000 (70)	7,500 (35)	10,000 (44.5)
4010460215	10	23.00 (584)	4.4 (112)	3.0 (76)	2.9 (1.3)	15	300	40 (55)	15,000 (70)	7,500 (35)	10,000 (44.5)

RUS Accepted

²SML — Specified Mechanical Load is the tension load that a Veri*Lite insulator can withstand during a 90-second test without failure. SML is comparable to the M&E strength rating of porcelain insulators.

³RTL — A Routine Test Load value is equal to 50% of the SML value.

⁴Proof Test — The mechanical tension load applied at the factory to each insulator for ten (10) seconds.

NOTE: PDI Type insulators are intended for applications which are within 75° of horizontal to allow proper shed drainage.

PDI Electrical Characteristics

0.625" (16mm) Diameter Rod Deadend Insulators

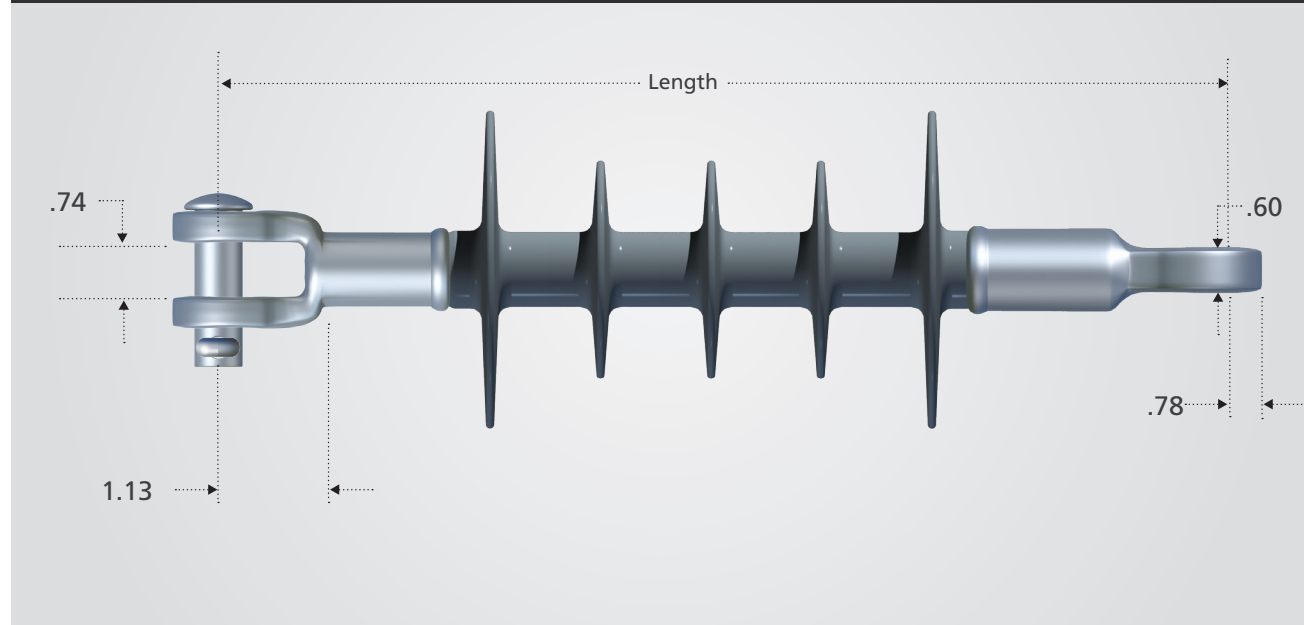

Electrical Characteristics

Catalog Numbers	Type	Leakage Distance Inches (mm)	Dry Arc Distance Inches (mm)	Flashover ANSI - kV		Critical Impulse Flashover		RIV		Power Arc kA cycles	SL of # of 4-1/4 Bells	Insulator Class
				Dry-kV	Wet-kV	Pos-kV	Neg-kV	Test kV	Max.			
4010150215	PDI-15	16 (406)	8.1 (205)	100	80	150	170	15	<10	150	2	DS15
4010280215	PDI-28	26 (660)	12.6 (320)	140	120	235	250	20	<10	150	—	DS28
4010250215	PDI-25	31 (787)	14.3 (363)	155	135	270	280	30	<10	150	3	DS35
4010350215	PDI-35	33 (838)	20 (508)	200	160	325	360	30	<10	150	4	—
4010460215	PDI-46	37.6 (955)	19.1 (485)	195	175	360	365	30	365	150	—	DS46

KEY TO THE CATALOG NUMBERS X01XXXX215

- 4 = ESPT™ Rubber
 - 8 = Silicone Rubber
 - 0 = Standard Pin
 - 1 = Hex Pin
 - 3 = Standard Pin Rotated End-fitting
 - 5 = ANSI 52-3 Ball & Socket
 - 6 = IEC 16mm Ball & Socket
- Type
- SML
 - Ferrous End-fitting
 - 0 = Standard Marking
 - 6 = CSA or Sample Testing

Example: Cat. #4013250215 is a Veri*Lite insulator, 25 kV. Rated with standard pin and rotated end-fitting (ferrous) 15,000 lbs. SML, plus standard markings.



VLS Mechanical Characteristics

0.625" (16mm) Diameter Rod Suspension Insulators

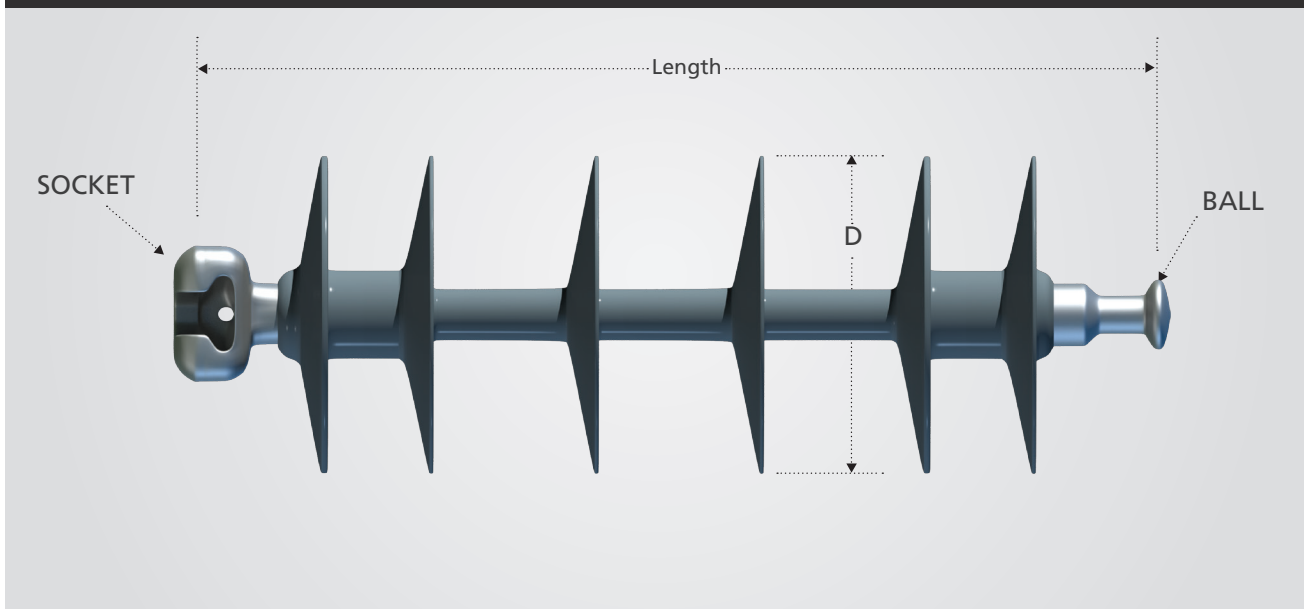

Mechanical Characteristics

Catalog Numbers	No. of Sheds	Length Inches (mm)	D Diameter Inches (mm)	Net Wt. pounds (kg)	Standard Package Qty		¹ SML pounds (kN)	² RTL pounds (kN)	³ Proof pounds (kN)
					Carton	Pallet			
4050021301	4	11.5 (292)	5.9 (150)	4 (1.8)	12	96	15,000 (70)	7,500 (35)	10,000 (44.5)
4050029001**	4	12.5 (318)	5.9 (150)	4 (1.8)	12	96	15,000 (70)	7,500 (35)	10,000 (44.5)
4050031301	6	17.25 (438)	5.9 (150)	4 (1.8)	12	96	15,000 (70)	7,500 (35)	10,000 (44.5)
4050041301	8	23 (584)	5.9 (150)	5 (2.3)	12	96	15,000 (70)	7,500 (35)	10,000 (44.5)
4050051301	10	28.75 (730)	5.9 (150)	6 (2.8)	12	48	15,000 (70)	7,500 (35)	10,000 (44.5)
4050061301	12	34.5 (876)	5.9 (150)	7 (3.2)	12	48	15,000 (70)	7,500 (35)	10,000 (44.5)

¹**SML** — Specified Mechanical Load is the tension load that a Veri*Lite insulator can withstand during a 90-second test without failure. SML is comparable to the M&E strength rating of porcelain insulators.

²**RTL** — A Routine Test Load value is equal to 50% of the SML value.

³**Proof Test** — The mechanical tension load applied at the factory to each insulator for ten (10) seconds.

VLS Electrical Characteristics

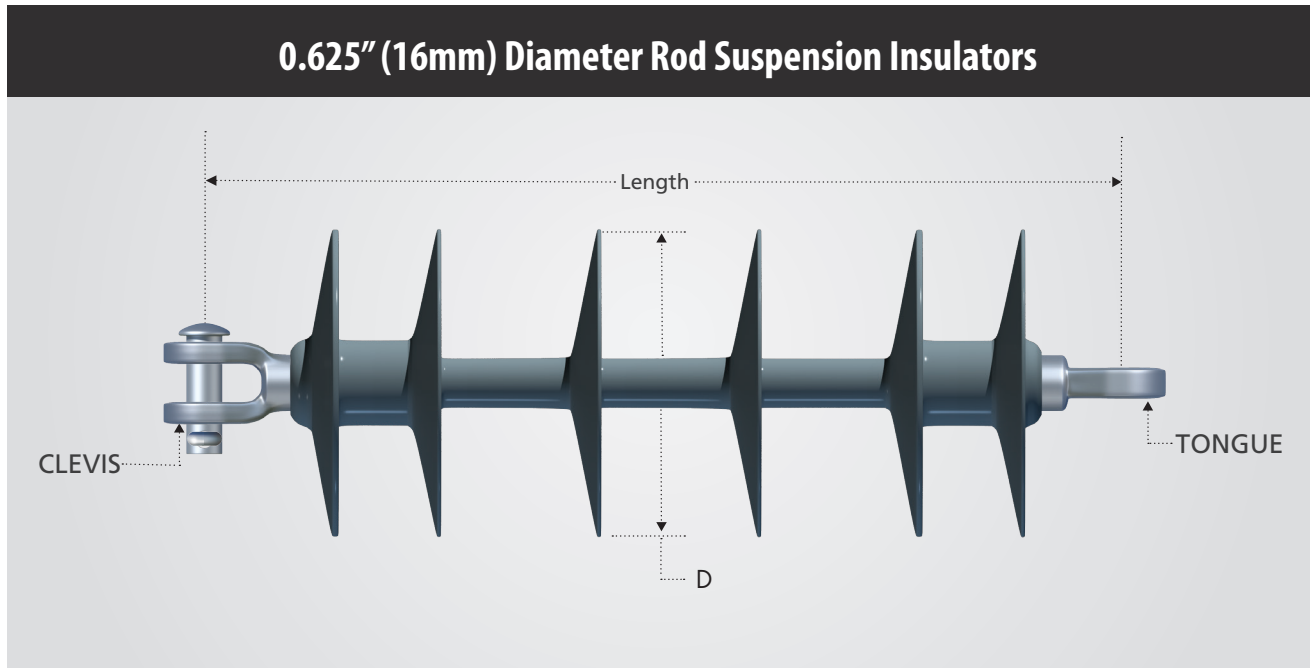

Electrical Characteristics

Catalog Numbers	Type	Leakage Distance Inches (mm)	Dry Arc Distance Inches (mm)	Flashover ANSI - kV		Critical Impulse Flashover		RIV		Power Arc kA cycles	Equivalent number of 5 3/4" X 10" Bells	Volt*/ Class
				Dry-kV	Wet-kV	Pos-kV	Neg-kV	Test kV	Max. μ V			
4050021301	VLS-2	23 (584)	11.75 (298)	135	110	225	255	21	<10	150	2	15/25
4050029001**	VLS-2	23 (584)	11.75 (298)	135	110	225	255	21	<10	150	2**	15/25
4050031301	VLS-3	39 (991)	18 (457)	190	140	320	330	32	<10	150	3	35/46
4050041301	VLS-4	54 (1372)	23.7 (602)	255	190	420	435	48	<10	150	4	46/69
4050051301	VLS-5	69 (1753)	29.5 (749)	315	245	500	510	48	<10	150	5	69
4050061301	VLS-6	84 (2134)	35.2 (894)	370	305	610	580	48	<10	150	6	69

* Phase-to-Phase voltage.

** Replaces two 10" x 6-1/4" distribution deadend bells.

*** Y-Clevis fitting only available on 405003 and above.

VLS insulators are available with ANSI and IEC ball/socket end fittings and also with clevis/tongue end fittings. Please use the following 4-digit suffix codes after the first 6-digits of the catalog number.

Suffix Code	Tower-end	Line-end
1201***	ANSI Y-Clevis	ANSI 52-3 Ball
1301	ANSI 52-3 Socket	ANSI 52-3 Ball
1400	ANSI 52-6 Clevis	ANSI 52-6 Tongue
2A07	IEC 16 mm Socket	IEC 16 mm Ball



End Fitting Details (Inches)

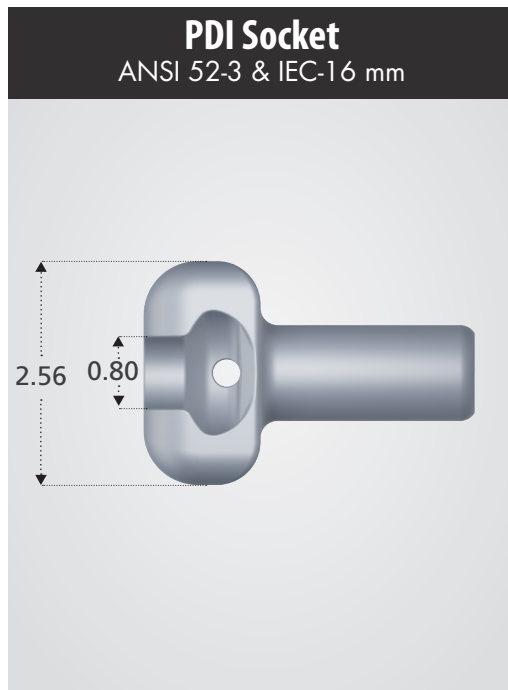
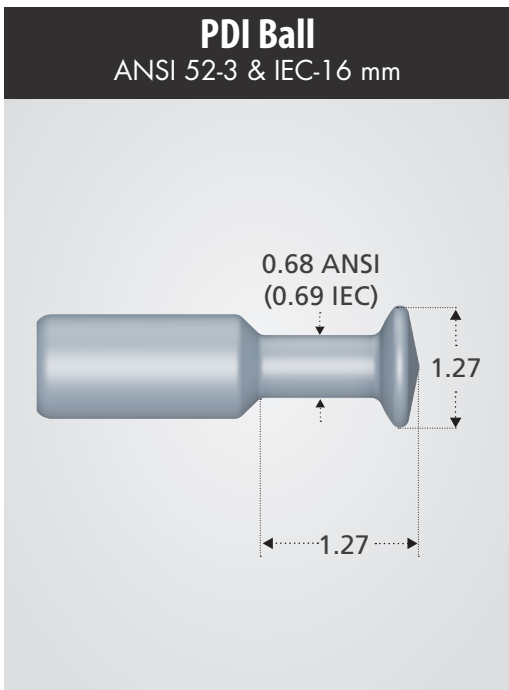
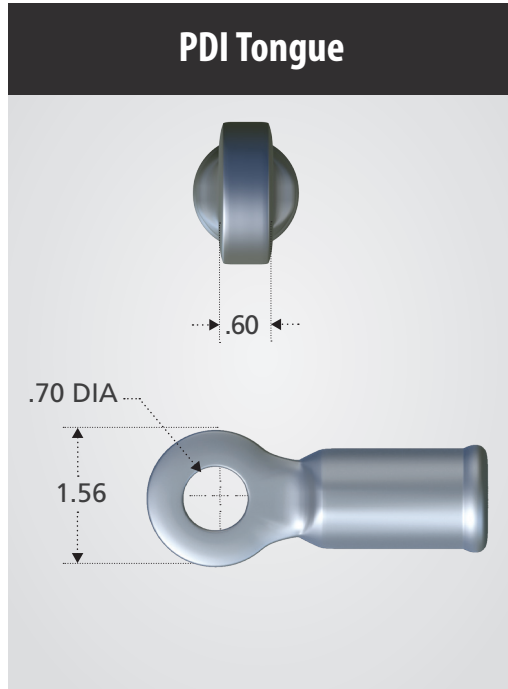
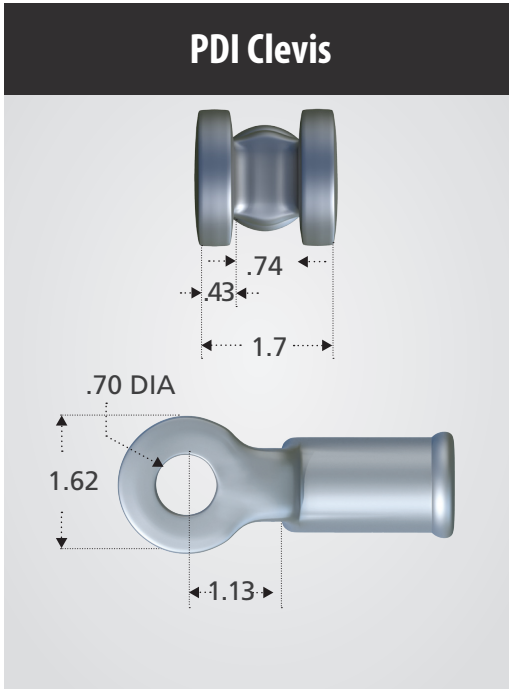

End Fitting Details (Inches)

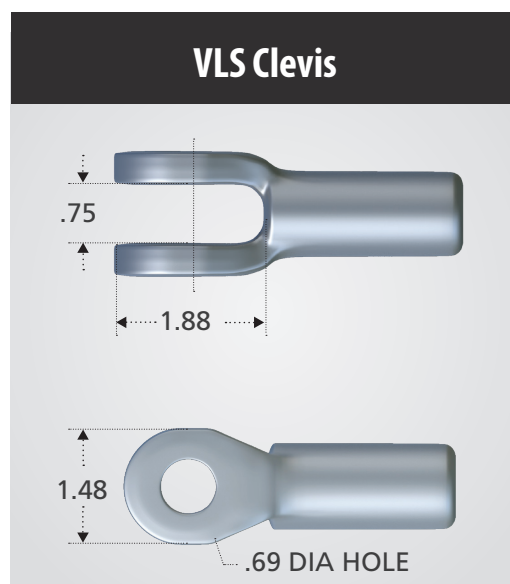

End Fitting Details (Inches)

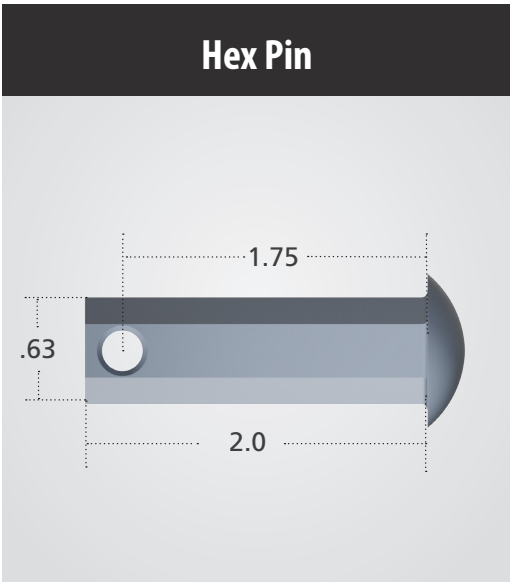
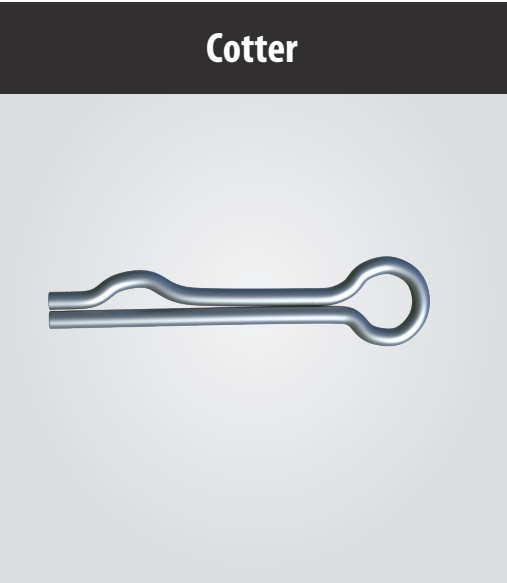



ENVIRONMENTAL PROTECTION

FOR YOUR LINES

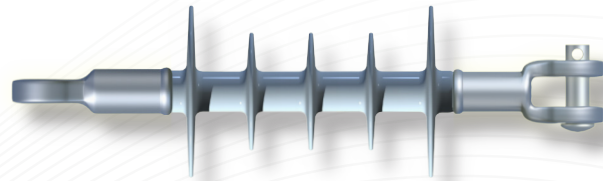

OHIO BRASS® SILICONE PDI™ INSULATOR *FOR COASTAL AND HIGHLY CONTAMINATED AREAS*

Hubbell Power Systems, Inc. has extended its PDI Insulator offering to include Silicone which provides greater protection in corrosive environments. Silicone rubber compounds have a high degree of hydrophobicity and high resistance to ultraviolet energy and heat, making the PDI the Insulators of choice.

For more information, visit hubbellpowersystems.com/insulators/dist/deadends/

DESIGNED IN THE U.S. - 25+ years experience in development of polymer deadend insulators

MADE IN THE U.S. - Manufactured in Aiken, SC with inventory in Centralia, MO

TESTED IN THE U.S. - Full HV test facility in Wadsworth, OH

PROVEN IN THE U.S. - 30 million in circulation and counting



NOTE: Because Hubbell has a policy of continuous product improvement, we reserve the right to change design and specifications without notice.

©Copyright 2015 Hubbell Incorporated

OHIO BRASS

Never Compromise™
www.hubbelpowersystems.com



Printed in USA

JUNE 2015