

# Assemblies







## Peace of Mind

*Hubbell Power Systems' (HPS) customers know that their hardware requirements — from metallurgy to finished product — are not only designed and manufactured with the utmost precision and electrical integrity, but they come together quickly and efficiently as well.*

With a full spectrum of tower hardware, this section lists Hubbell's standard transmission tangent, angle, deadend, and jumper assemblies which include Anderson™ and Fargo® Connectors and Quadri\*Sil™ Insulators. The assemblies are grouped by voltage (Standard or EHV), number of conductors, general assembly type, and strength of insulators. See Table of Contents for further clarification.

Each assembly is defined by a Base Assembly Catalog Number which includes all items in the bill of material chart shown. However, this assembly number alone will not specify an exact bill of material until final customer-specific information is provided, i.e., Tangent assemblies require the customer to provide conductor and specific voltage information to select the exact suspension clamp and insulator to be included.

For your convenience, a tabulated insulator chart is included which provides the most common insulator part number for each applicable voltage for that given assembly. Please see quoting and ordering instructions below.

### For Quotes and Ordering

1. Select Base Assembly Catalog number based on Voltage, Number of Conductors, Assembly Type, and Insulator String Strength (e.g., TAA-IH-21-30 for Standard Voltage, 2 Conductors, Angle Assembly, 30k Insulator String Strength).
2. Specify Conductor Size, Type and Stranding to be used (e.g., 795 kcmil, ACSS, 26/7).
3. Specify whether armor rods or line guards will be used on the conductor.

**NOTE:** The suspension clamp/deadend assembly, armor rods/line guards (if required), and the specific insulator will be chosen by HPS based on selection criteria provided by the customer.



# Tangent Suspension, Single Conductor

## Single-String 30k lb Assembly, TAT-IX-11-30, 69kV - 230kV

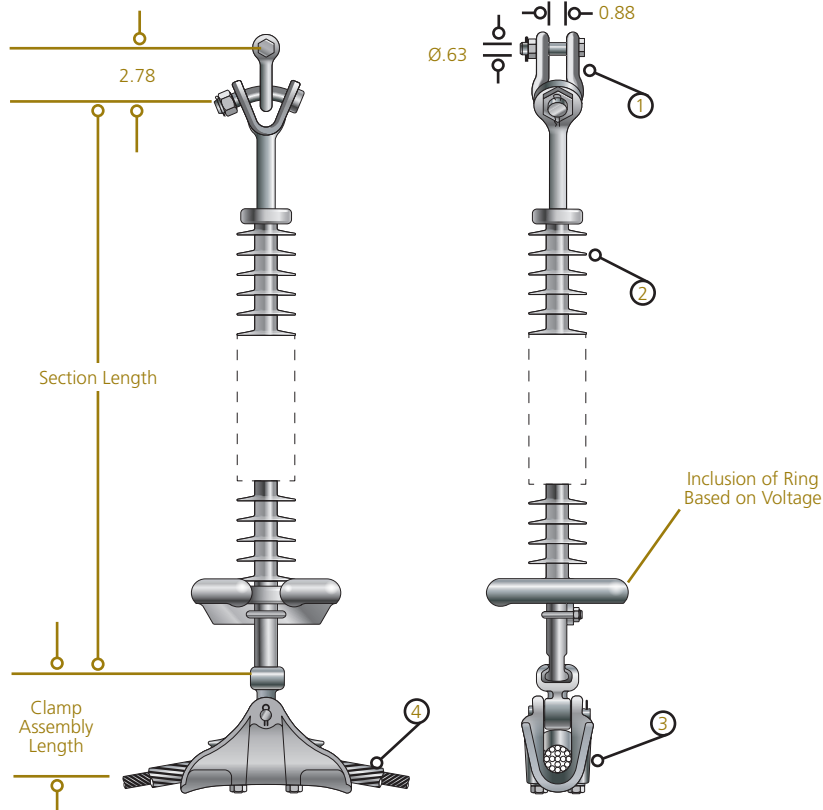

### Base Assembly Catalog Number: TAT-IX-11-30

Item	Part Number	Description	Quantity	Material	UBS lb
1	AS25LBNK	Anchor Shackle	1	Forged Steel	30,000
2	See Chart	Insulator, ANSI 52-5	1	Polymer	—
3	See Note 1	Suspension Clamp w/Socket	1	Aluminum	—
4	See Note 2	Armor Rods	1	Aluminum	—

### Typical Insulator Selection — See Note 3

Line Voltage (kV)	Quadri*Sil® Part Number	Section Length Inches	SML lb	Corona Ring
69	S030023S2010	35.4	30,000	—
115	S030036S2010	48.4	30,000	—
138	S030043S2010	54.9	30,000	—
161	S030056S2010	67.8	30,000	—
230	S030073S201A	85.1	30,000	8" Line End

**NOTE:** For quoting/ordering instructions, see Assemblies section.

- (1) See Suspension Clamp section for standard and high temperature conductor suspension clamp options.
- (2) Contact HPS for armor rod recommendations.
- (3) See Suspension Insulator section for additional insulator options, including 25k lb offerings.



# Tangent Suspension, Single Conductor

## V-String 30k lb Assembly, TAT-VX-12-30, 69kV - 230kV

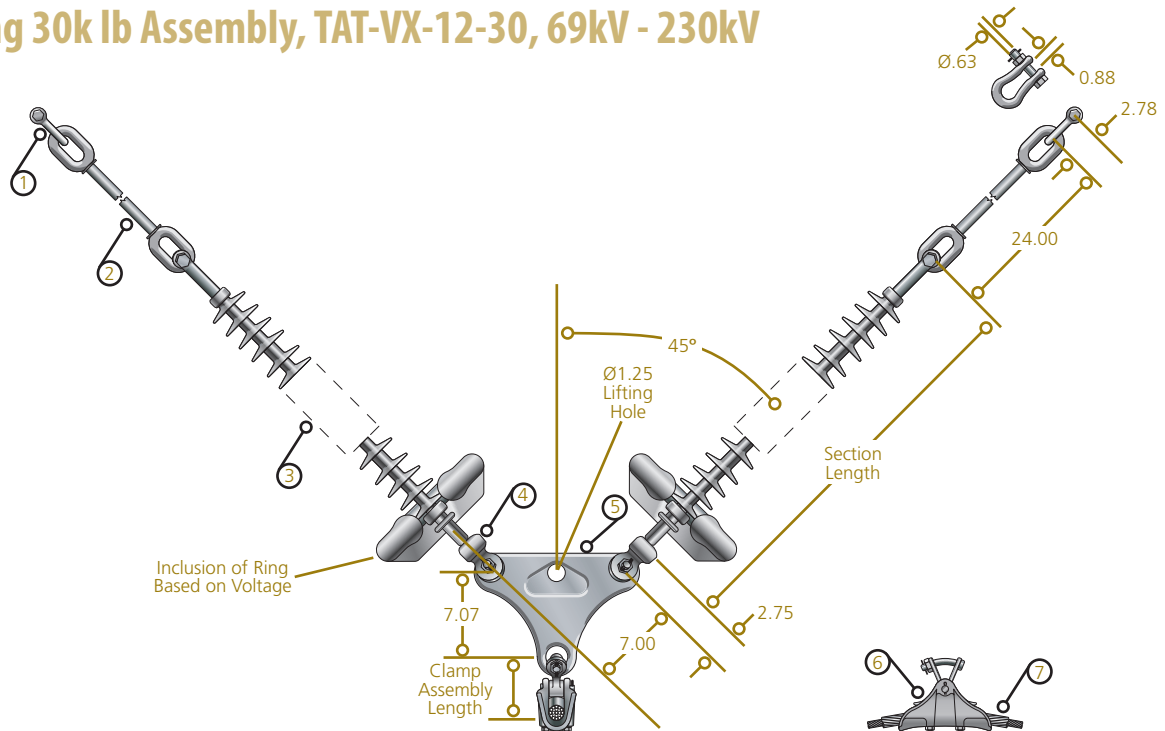

**Base Assembly Catalog Number: TAT-VX-12-30**

Item	Part Number	Description	Quantity	Material	UBS lb
1	AS25LBNK	Anchor Shackle	2	Forged Steel	30,000
2	H003024	Oval Eye Ext. Link (24")	2	Forged Steel	30,000
3	See Chart	Insulator, ANSI 52-5	2	Polymer	—
4	SYC30	Socket Y-Clevis	2	Ductile Iron	30,000
5	YPD30152382	Yoke Plate	1	Ductile Iron	30,000
6	See Note 1	Suspension Clamp w/Y-Clevis Eye	1	Aluminum	—
7	See Note 2	Armor Rods	1	Aluminum	—

### Typical Insulator Selection — See Note 3

Line Voltage (kV)	Quadri*Sil® Part Number	Section Length Inches	SML lb	Corona Ring
69	S030023S2010	35.4	30,000	—
115	S030036S2010	48.4	30,000	—
138	S030043S2010	54.9	30,000	—
161	S030056S2010	67.8	30,000	—
230	S030073S201A	85.1	30,000	8" Line End

**NOTE:** For quoting/ordering instructions, see Assemblies section.

- (1) See Suspension Clamp section for standard and high temperature conductor suspension clamp options.
- (2) Contact HPS for armor rod recommendations.
- (3) See Suspension Insulator section for additional insulator options, including 25k lb offerings.

# Tangent Suspension, 2-Bundle Conductor

## Single-String 30k lb Assembly, TAT-IH-21-30, 138kV - 230kV

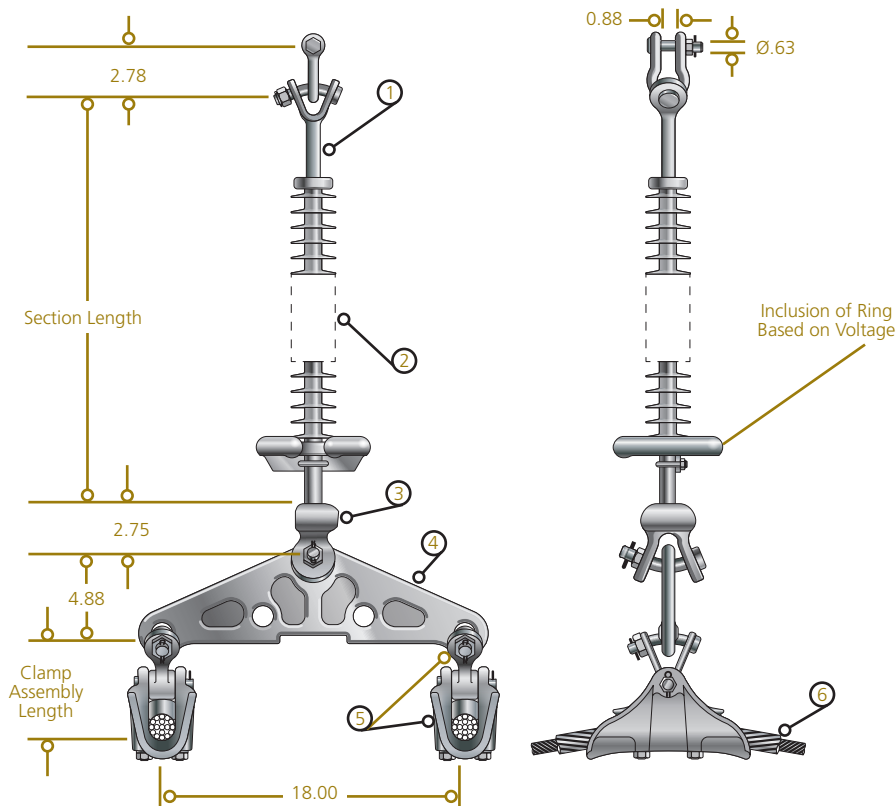

### Base Assembly Catalog Number: TAT-IH-21-30

Item	Part Number	Description	Quantity	Material	UBS lb
1	AS25LBNK	Anchor Shackle	1	Forged Steel	30,000
2	See Chart	Insulator, ANSI 52-5	1	Polymer	—
3	SYC30	Socket Y-Clevis	1	Ductile Iron	30,000
4	YPD30184373	Yoke Plate	1	Ductile Iron	30,000
5	See Note 1	Suspension Clamp w/Y-Clevis Eye	2	Aluminum	—
6	See Note 2	Armor Rods	2	Aluminum	—

### Typical Insulator Selection — See Note 3

Line Voltage (kV)	Quadri*Sil® Part Number	Section Length Inches	SML lb	Corona Ring
138	S030043S2010	54.9	30,000	—
161	S030056S2010	67.8	30,000	—
230	S030073S201A	85.1	30,000	8" Line End

- NOTE:** For quoting/ordering instructions, see Assemblies section.
- (1) See Suspension Clamp section for standard and high temperature conductor suspension clamp options.
  - (2) Contact HPS for armor rod recommendations.
  - (3) See Suspension Insulator section for additional insulator options, including 25k lb offerings.

# Tangent Suspension, 2-Bundle Conductor

## Single-String 50k lb Assembly, TAT-IH-21-50, 138kV - 230kV

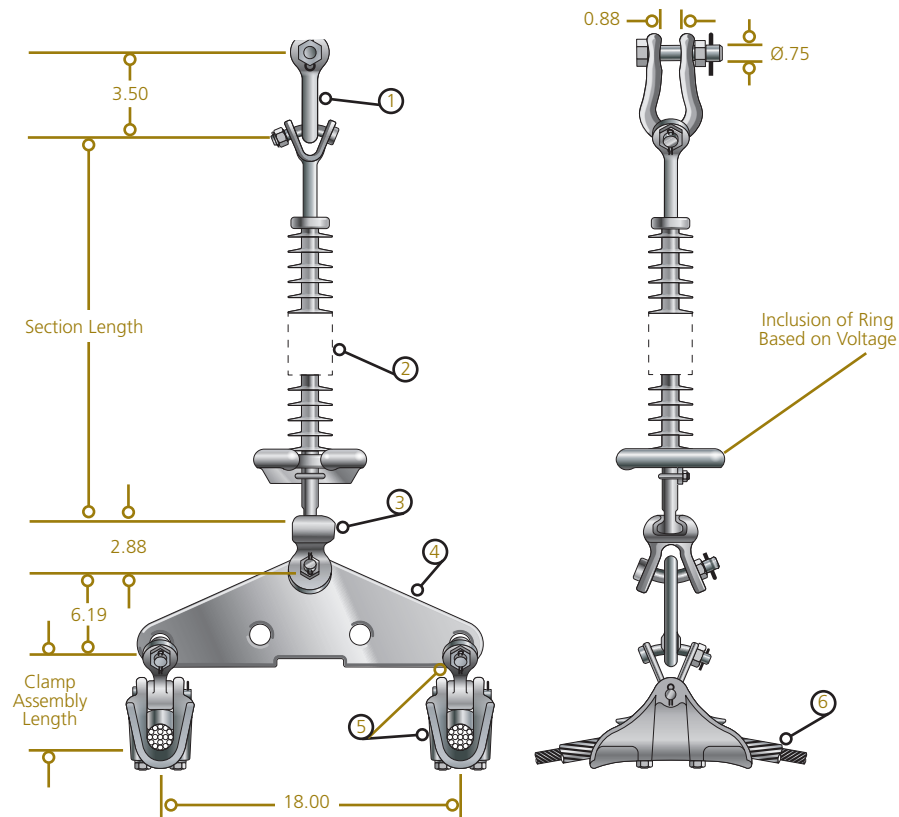

### Base Assembly Catalog Number: TAT-IH-21-50

Item	Part Number	Description	Quantity	Material	UBS lb
1	AS50BNK	Anchor Shackle	1	Forged Steel	60,000
2	See Chart	Insulator, ANSI 52-11	1	Polymer	—
3	SYC50	Socket Y-Clevis	1	Ductile Iron	50,000
4	YPD50185491	Yoke Plate	1	Ductile Iron	50,000
5	See Note 1	Suspension Clamp w/Y-Clevis	2	Aluminum	—
6	See Note 2	Armor Rods	2	Aluminum	—

### Typical Insulator Selection — See Note 3

Line Voltage (kV)	Quadri*Sil® Part Number	Section Length Inches	SML lb	Corona Ring
138	S050043S2010	57.3	50,000	—
161	S050056S2010	70.3	50,000	—
230	S050073S201A	87.6	50,000	8" Line End

- NOTE:** For quoting/ordering instructions, see Assemblies section.
- (1) See Suspension Clamp section for standard and high temperature conductor suspension clamp options.
  - (2) Contact HPS for armor rod recommendations.
  - (3) See Suspension Insulator section for additional insulator options.



# Tangent Suspension, 2-Bundle Conductor

## V-String 30k lb Assembly, TAT-VH-22-30, 138kV - 230kV

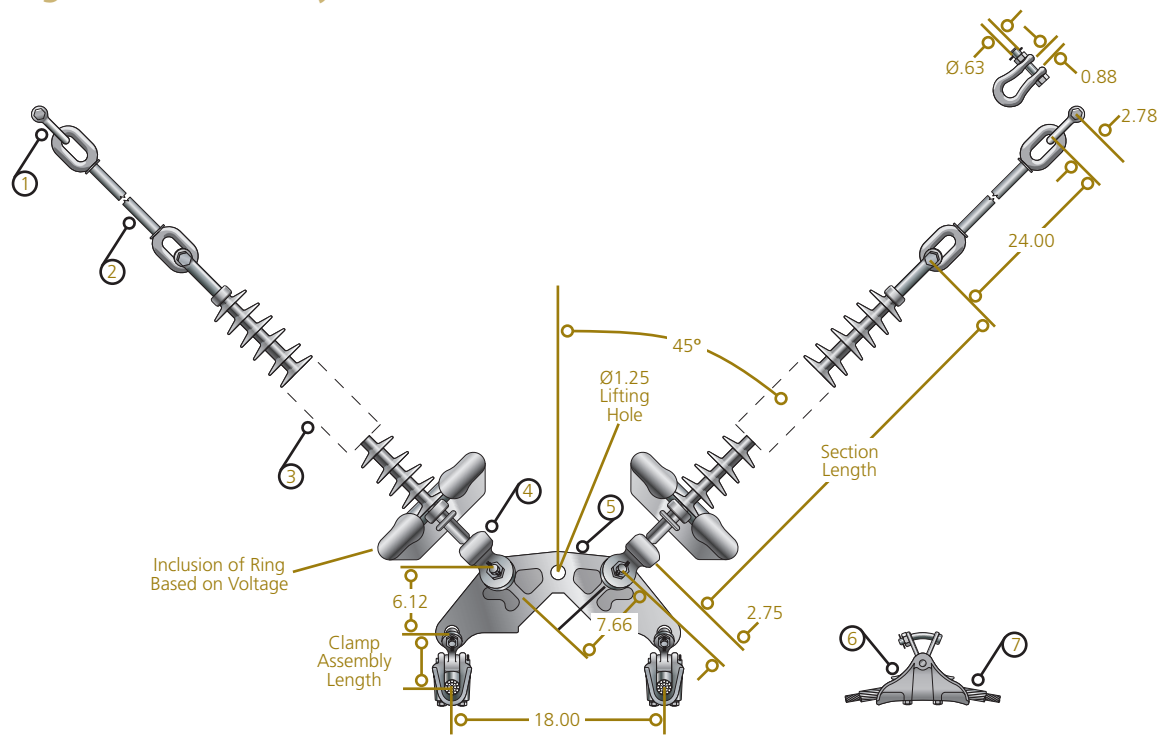

### Base Assembly Catalog Number: TAT-VH-22-30

Item	Part Number	Description	Quantity	Material	UBS lb
1	AS25LBNK	Anchor Shackle	2	Forged Steel	30,000
2	H003024	Oval Eye Ext. Link (24")	2	Forged Steel	30,000
3	See Chart	Insulator, ANSI 52-5	2	Polymer	—
4	SYC30	Socket Y-Clevis	2	Ductile Iron	30,000
5	YPV30172592	Yoke Plate	1	Ductile Iron	30,000
6	See Note 1	Suspension Clamp w/Y-Clevis Eye	2	Aluminum	—
7	See Note 2	Armor Rods	2	Aluminum	—

### Typical Insulator Selection — See Note 3

Line Voltage (kV)	Quadri*Sil® Part Number	Section Length Inches	SML lb	Corona Ring
138	S030043S2010	54.9	30,000	—
161	S030056S2010	67.8	30,000	—
230	S030073S201A	85.1	30,000	8" Line End

- NOTE:** For quoting/ordering instructions, see Assemblies section.
- (1) See Suspension Clamp section for standard and high temperature conductor suspension clamp options.
  - (2) Contact HPS for armor rod recommendations.
  - (3) See Suspension Insulator section for additional insulator options, including 25k lb offerings.

# Tangent Suspension, 2-Bundle Conductor

## V-String 50k lb Assembly, TAT-VH-22-50, 138kV - 230kV

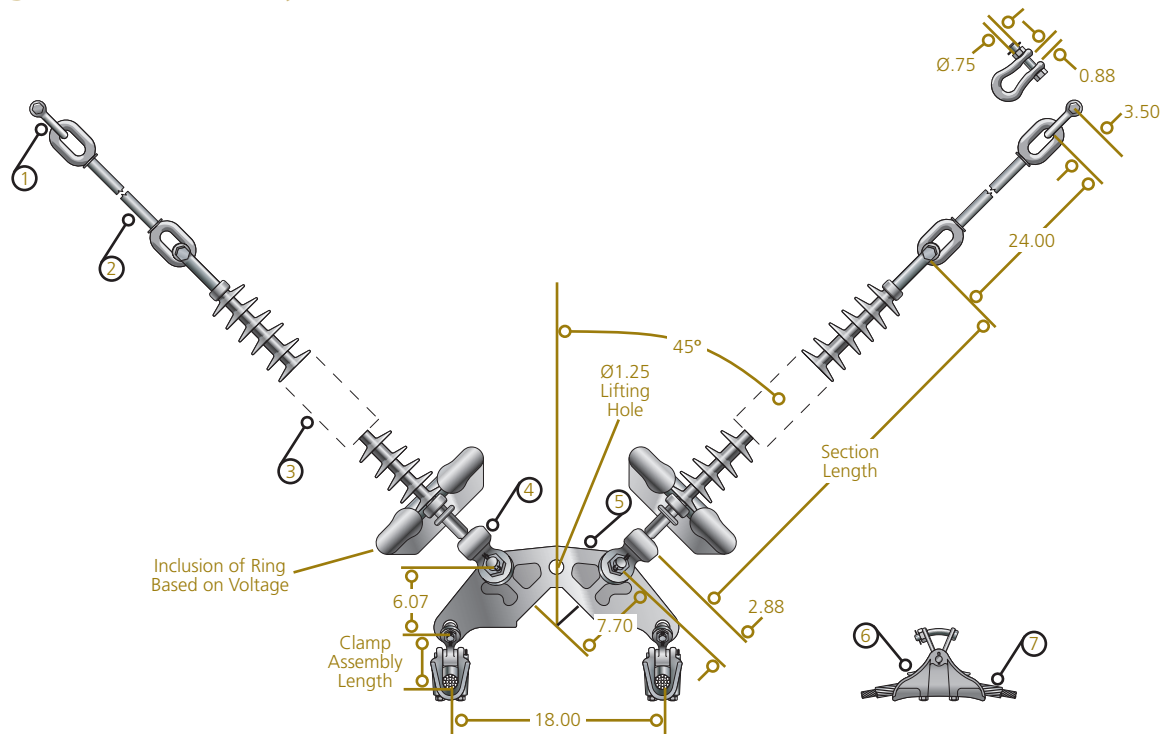

### Base Assembly Catalog Number: TAT-VH-22-50

Item	Part Number	Description	Quantity	Material	UBS lb
1	AS50BNK	Anchor Shackle	2	Forged Steel	60,000
2	H005024	Oval Eye Ext. Link (24")	1	Forged Steel	60,000
3	See Chart	Insulator, ANSI 52-11	2	Polymer	—
4	SYC50	Socket Y-Clevis	2	Ductile Iron	50,000
5	YPV5019011	Yoke Plate	1	Ductile Iron	50,000
6	See Note 1	Suspension Clamp w/Y-Clevis Eye	2	Aluminum	—
7	See Note 2	Armor Rods	2	Aluminum	—

### Typical Insulator Selection — See Note 3

Line Voltage (kV)	Quadri*Sil® Part Number	Section Length Inches	SML lb	Corona Ring
138	S050043S2010	57.3	50,000	—
161	S050056S2010	70.3	50,000	—
230	S050073S201A	87.6	50,000	8" Line End

**NOTE:** For quoting/ordering instructions, see Assemblies section.

- (1) See Suspension Clamp section for standard and high temperature conductor suspension clamp options.
- (2) Contact HPS for armor rod recommendations.
- (3) See Suspension Insulator section for additional insulator options.

# Angle Suspension, 2-Bundle Conductor

## Running Angle 30k lb Assembly, TAA-IH-21-30, 138kV - 230kV

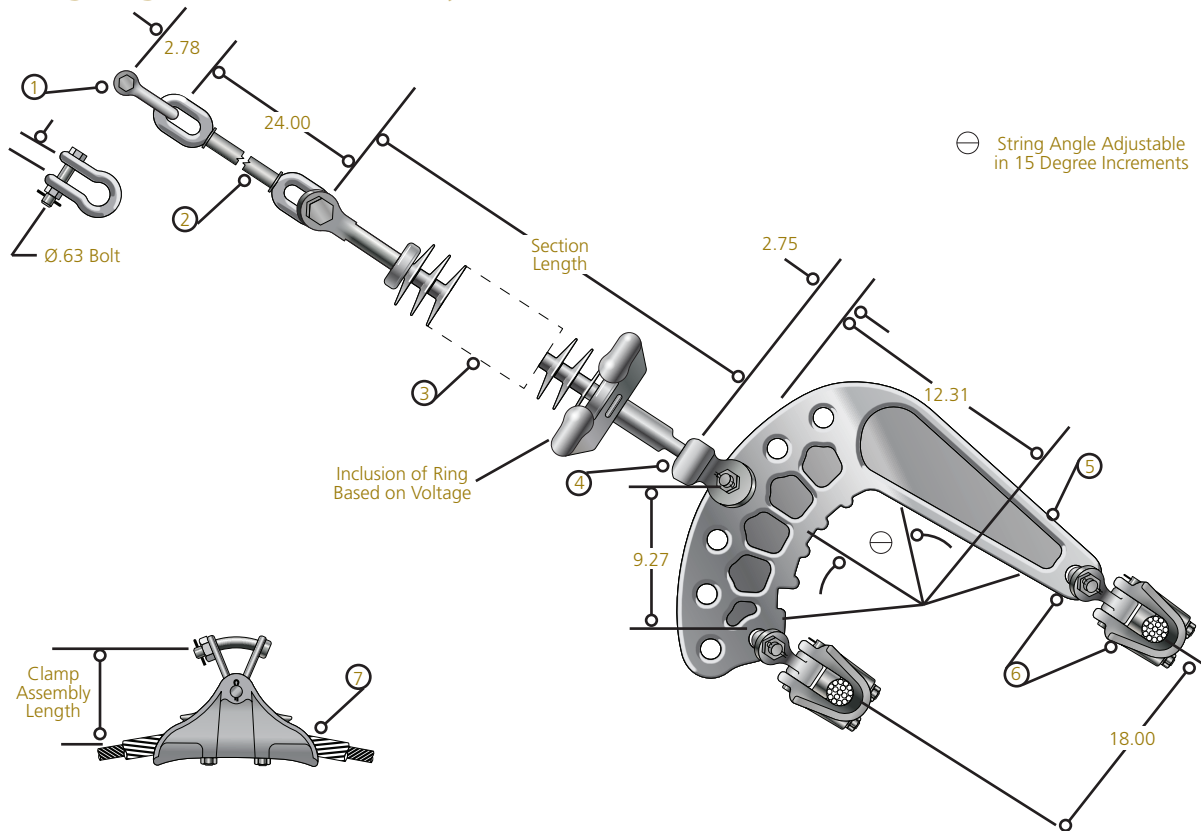

### Base Assembly Catalog Number: TAA-IH-21-30

Item	Part Number	Description	Quantity	Material	UBS lb
1	AS25LBNK	Anchor Shackle	1	Forged Steel	30,000
2	H003024	Oval Eye Ext. Link (24")	1	Forged Steel	30,000
3	See Chart	Insulator, ANSI 52-5	1	Polymer	—
4	SYC30	Socket Y-Clevis	1	Ductile Iron	30,000
5	YPC5026001	Yoke Plate	1	Ductile Iron	50,000
6	See Note 1	Suspension Clamp w/Y-Clevis Eye	2	Aluminum	—
7	See Note 2	Armor Rods	2	Aluminum	—

### Typical Insulator Selection — See Note 3

Line Voltage (kV)	Quadri*Sil® Part Number	Section Length Inches	SML lb	Corona Ring
138	S030043S2010	54.9	30,000	—
161	S030056S2010	67.8	30,000	—
230	S030073S201A	85.1	30,000	8" Line End

**NOTE:** For quoting/ordering instructions, see Assemblies section.

- (1) See Suspension Clamp section for standard and high temperature conductor suspension clamp options.
- (2) Contact HPS for armor rod recommendations.
- (3) See Suspension Insulator section for additional insulator options, including 25k lb offerings.



# Angle Suspension, 2-Bundle Conductor

## Running Angle 50k lb Assembly, TAA-IH-21-50, 138kV - 230kV

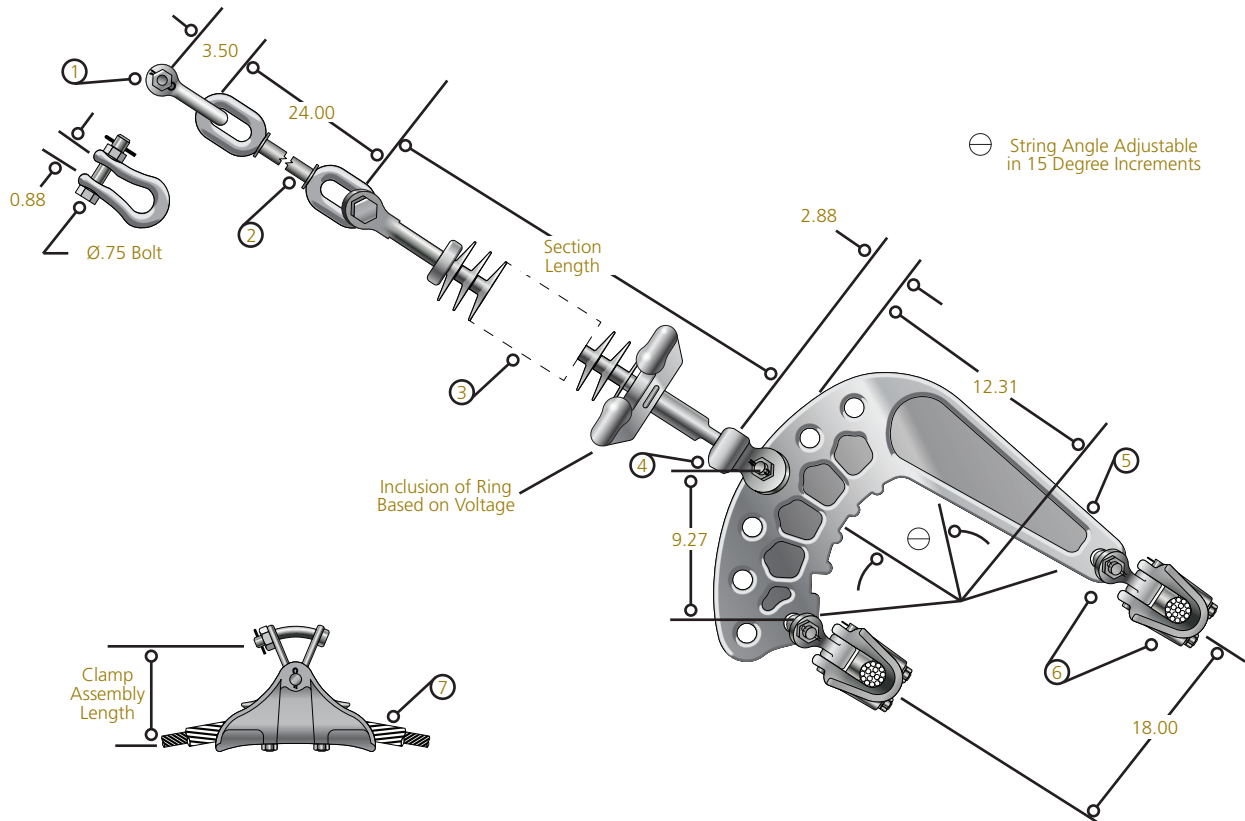

### Base Assembly Catalog Number: TAA-IH-21-50

Item	Part Number	Description	Quantity	Material	UBS lb
1	AS50BNK	Anchor Shackle	1	Forged Steel	60,000
2	H005024	Oval Eye Ext. Link (24")	1	Forged Steel	60,000
3	See Chart	Insulator, ANSI 52-5	1	Polymer	—
4	SYC50	Socket Y-Clevis	1	Ductile Iron	50,000
5	YPC5026001	Yoke Plate	1	Ductile Iron	50,000
6	See Note 1	Suspension Clamp w/Y-Clevis Eye	2	Aluminum	—
7	See Note 2	Armor Rods	2	Aluminum	—

### Typical Insulator Selection — See Note 3

Line Voltage (kV)	Quadri*Sil® Part Number	Section Length Inches	SML lb	Corona Ring
138	S050043S2010	57.3	50,000	—
161	S050056S2010	70.3	50,000	—
230	S050073S201A	87.6	50,000	8" Line End

**NOTE:** For quoting/ordering instructions, see Assemblies section.

- (1) See Suspension Clamp section for standard and high temperature conductor suspension clamp options.
- (2) Contact HPS for armor rod recommendations.
- (3) See Suspension Insulator section for additional insulator options.

# Angle Suspension, 2-Bundle Conductor

## Running Angle 30k lb Assembly, TAA-VH-22-30, 138kV - 230kV

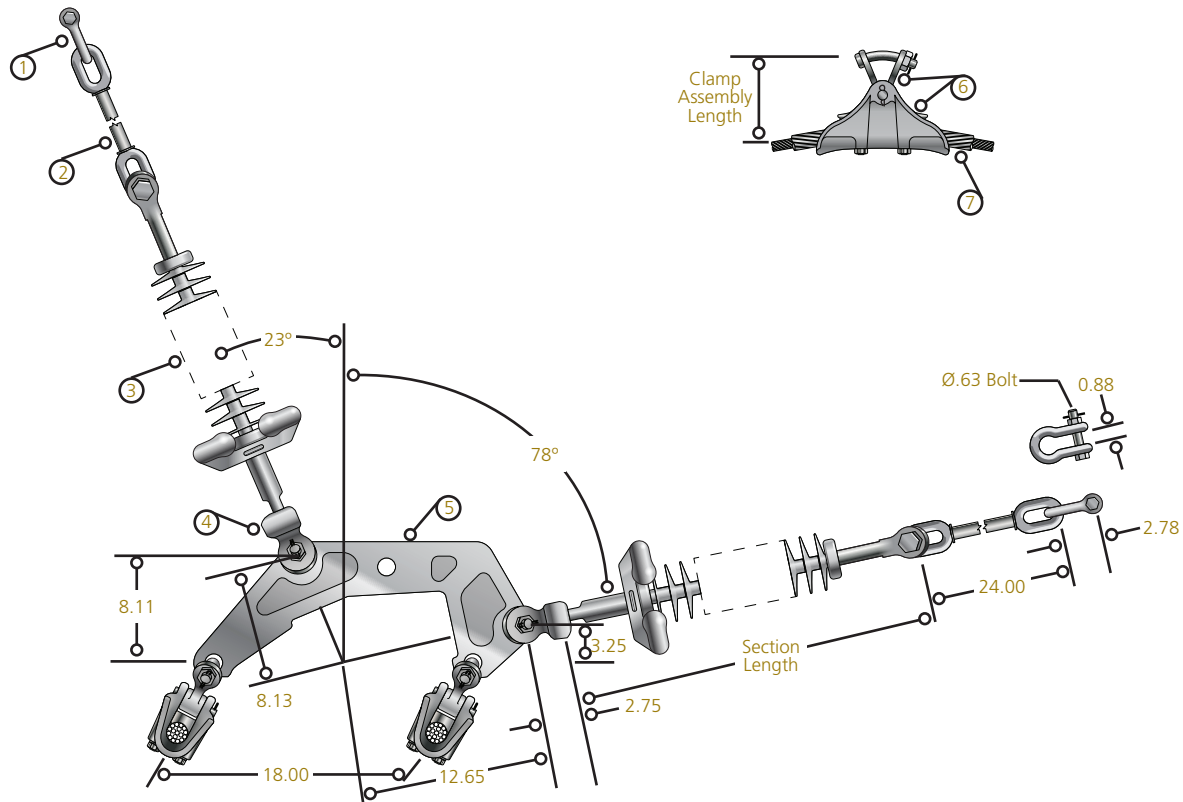

### Base Assembly Catalog Number: TAA-VH-22-30

Item	Part Number	Description	Quantity	Material	UBS lb
1	AS25LBNK	Anchor Shackle	2	Forged Steel	30,000
2	H003024	Oval Eye Ext. Link (24")	2	Forged Steel	30,000
3	See Chart	Insulator, ANSI 52-5	2	Polymer	—
4	SYC30	Socket Y-Clevis	2	Ductile Iron	30,000
5	YPC30174241	Yoke Plate	1	Ductile Iron	30,000
6	See Note 1	Suspension Clamp w/Y-Clevis Eye	2	Aluminum	—
7	See Note 2	Armor Rods	2	Aluminum	—

### Typical Insulator Selection — See Note 3

Line Voltage (kV)	Quadri*Sil® Part Number	Section Length Inches	SML lb	Corona Ring
138	S030043S2010	54.9	30,000	—
161	S030056S2010	67.8	30,000	—
230	S030073S201A	85.1	30,000	8" Line End

**NOTE:** For quoting/ordering instructions, see Assemblies section.

- (1) See Suspension Clamp section for standard and high temperature conductor suspension clamp options.
- (2) Contact HPS for armor rod recommendations.
- (3) See Suspension Insulator section for additional insulator options, including 25k lb offerings.

# Angle Suspension, 2-Bundle Conductor

## Angle V 50k lb Assembly, TAA-VH-22-50, 138kV - 230kV

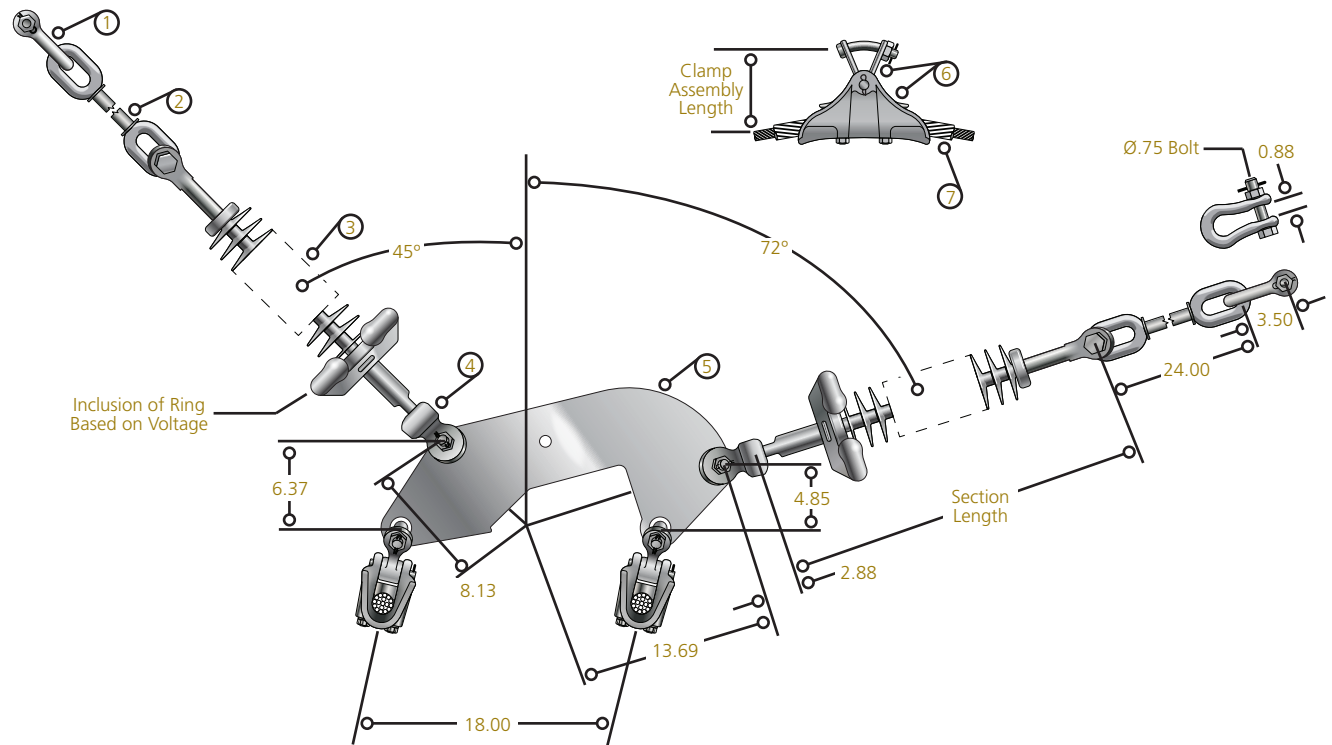

### Base Assembly Catalog Number: TAA-VH-22-50

Item	Part Number	Description	Quantity	Material	UBS lb
1	AS50BNK	Anchor Shackle	2	Forged Steel	60,000
2	H005024	Oval Eye Ext. Link (24")	2	Forged Steel	60,000
3	See Chart	Insulator, ANSI 52-11	2	Polymer	—
4	SYC50	Socket Y-Clevis	2	Ductile Iron	50,000
5	945834005	Yoke Plate	1	Steel	50,000
6	See Note 1	Suspension Clamp w/Y-Clevis Eye	2	Aluminum	—
7	See Note 2	Armor Rods	2	Aluminum	—

### Typical Insulator Selection — See Note 3

Line Voltage (kV)	Quadri*Sil® Part Number	Section Length Inches	SML lb	Corona Ring
138	S050043S2010	57.3	50,000	—
161	S050056S2010	70.3	50,000	—
230	S050073S201A	87.6	50,000	8" Line End

**NOTE:** For quoting/ordering instructions, see Assemblies section.

- (1) See Suspension Clamp section for standard and high temperature conductor suspension clamp options.
- (2) Contact HPS for armor rod recommendations.
- (3) See Suspension Insulator section for additional insulator options.



# Deadend, Single Conductor

## Single Insulator 30k lb Assembly, TAD-1X-11-30, 69kV - 230kV

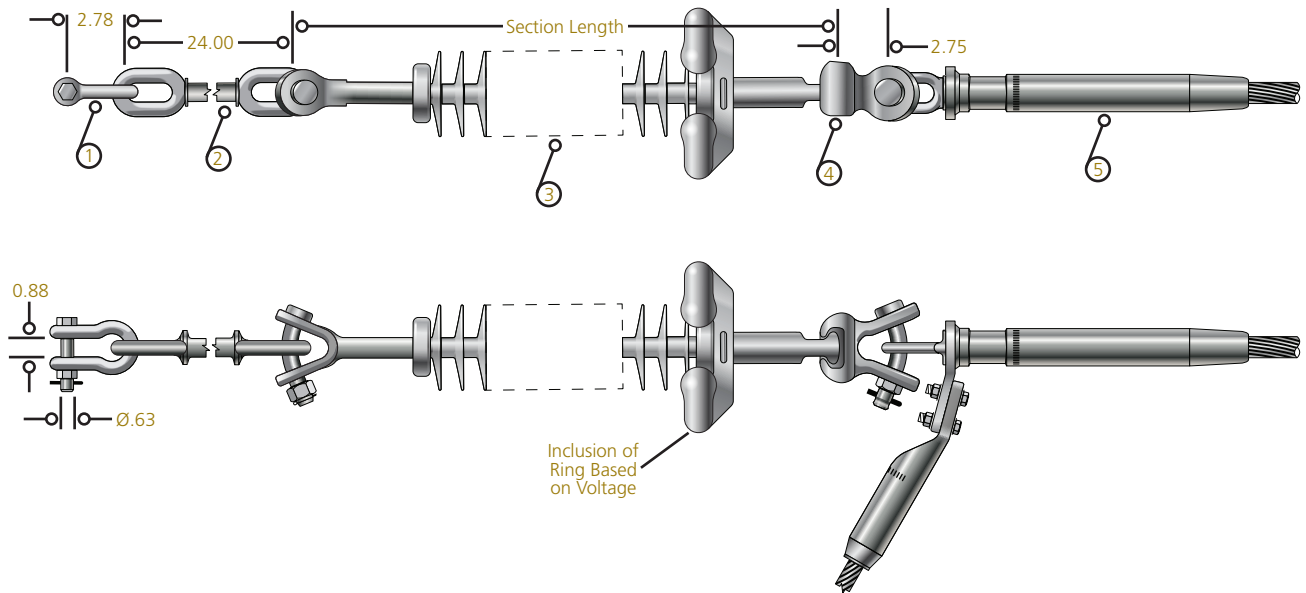

### Base Assembly Catalog Number: TAD-1X-11-30

Item	Part Number	Description	Quantity	Material	UBS lb
1	AS25LBNK	Anchor Shackle	1	Forged Steel	30,000
2	H003024	Oval Eye Ext. Link (24")	1	Forged Steel	30,000
3	See Chart	Insulator, ANSI 52-5	1	Polymer	—
4	SYC30	Socket Y-Clevis	1	Ductile Iron	30,000
5	See Note 1	Compression Deadend w/Terminal	1	Aluminum	Full Tension

### Typical Insulator Selection — See Note 2

Line Voltage (kV)	Quadri*Sil® Part Number	Section Length Inches	SML lb	Corona Ring
69	S030023S2010	35.4	30,000	—
115	S030036S20100	48.4	30,000	—
138	S030043S2010	54.9	30,000	—
161	S030056S2010	67.8	30,000	—
230	S030073S201A	85.1	30,000	8" Line End

**NOTE:** For quoting/ordering instructions, see Assemblies section.

- (1) See Compression Deadends section for standard conductor compression deadend options, See Compression Conventional (Two Die) System section for high temperature conductor compression deadend options.
- (2) See Suspension Insulator section for additional insulator options, including 25k lb offerings.

# Deadend, Single Conductor

## Single Insulator 50k lb Assembly, TAD-1X-11-50, 69kV - 230kV

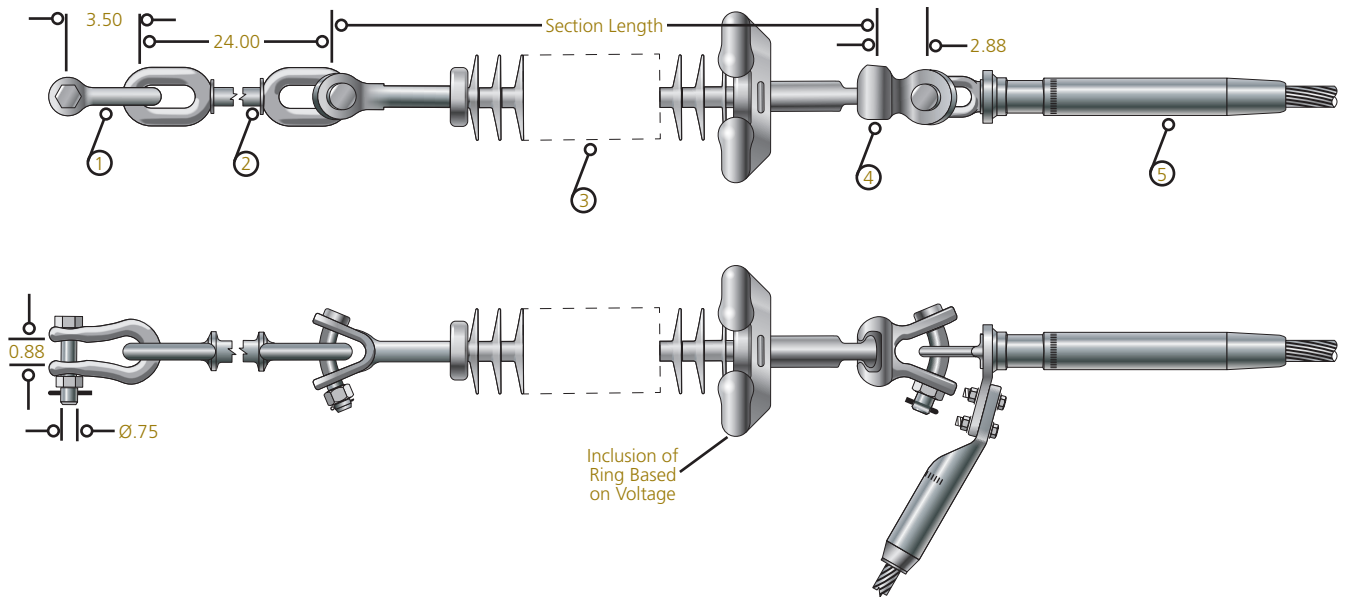

### Base Assembly Catalog Number: TAD-1X-11-50

Item	Part Number	Description	Quantity	Material	UBS lb
1	AS50BNK	Anchor Shackle	1	Forged Steel	60,000
2	H005024	Oval Eye Ext. Link (24")	1	Forged Steel	60,000
3	See Chart	Insulator, ANSI 52-11	1	Polymer	—
4	SYC50	Socket Y-Clevis	1	Ductile Iron	50,000
5	See Note 1	Compression Deadend w/Terminal	1	Aluminum	Full Tension

### Typical Insulator Selection — See Note 2

Line Voltage (kV)	Quadri*Sil® Part Number	Section Length Inches	SML lb	Corona Ring
69	S050023S2010	37.9	50,000	—
115	S050036S2010	50.8	50,000	—
138	S050043S2010	57.3	50,000	—
161	S050056S2010	70.3	50,000	—
230	S050073S201A	87.6	50,000	8" Line End

**NOTE:** For quoting/ordering instructions, see Assemblies section.

- (1) See Compression Deadends for standard conductor compression deadend options, See Compression Conventional (Two Die) System section for high temperature conductor compression deadend options.
- (2) See Suspension Insulator section for additional insulator options.

# Deadend, Single Conductor

## Double Insulator 30k lb Assembly, TAD-1X-12-30, 69kV - 230kV

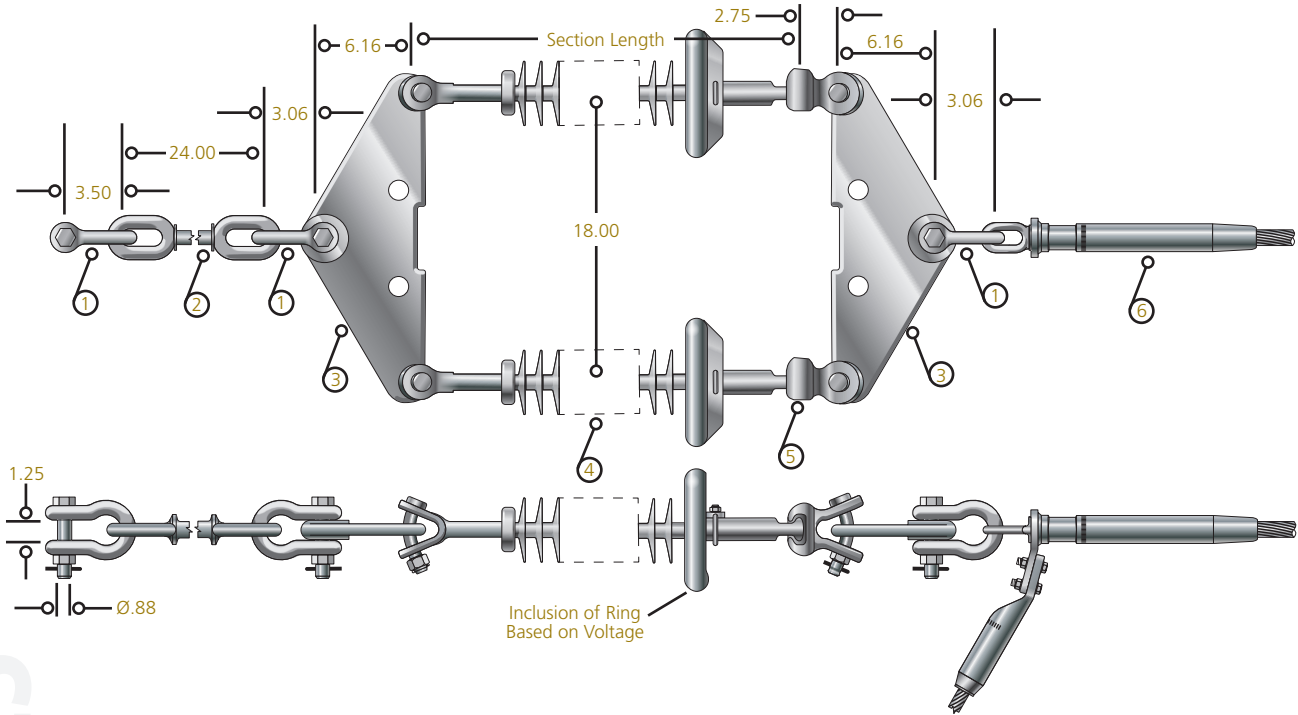

### Base Assembly Catalog Number: TAD-1X-12-30

Item	Part Number	Description	Quantity	Material	UBS lb
1	AS50WBNK	Anchor Shackle	3	Forged Steel	60,000
2	H005024	Oval Eye Ext. Link (24")	1	Forged Steel	60,000
3	YPD60183771	Yoke Plate	2	Ductile Iron	60,000
4	See Chart	Insulator, ANSI 52-5	2	Polymer	—
5	SYC30	Socket Y-Clevis	2	Ductile Iron	30,000
6	See Note 1	Compression Deadend w/Terminal	1	Aluminum	Full Tension

### Typical Insulator Selection — See Note 2

Line Voltage (kV)	Quadri*Sil® Part Number	Section Length Inches	SML lb	Corona Ring
69	S030023S2010	35.4	30,000	—
115	S030036S2010	48.4	30,000	—
138	S030043S2010	54.9	30,000	—
161	S030056S2010	67.8	30,000	—
230	S030073S201A	85.1	30,000	8" Line End

**NOTE:** For quoting/ordering instructions, see Assemblies section.

- (1) See Compression Deadends section for standard conductor compression deadend options, See Compression Conventional (Two Die) System section for high temperature conductor compression deadend options.
- (2) See Suspension Insulator section for additional insulator options, including 25k lb offerings.



# Deadend, 2-Bundle Conductor

## Single Insulator 50k lb Assembly, TAD-1X-21-50, 138kV - 230kV

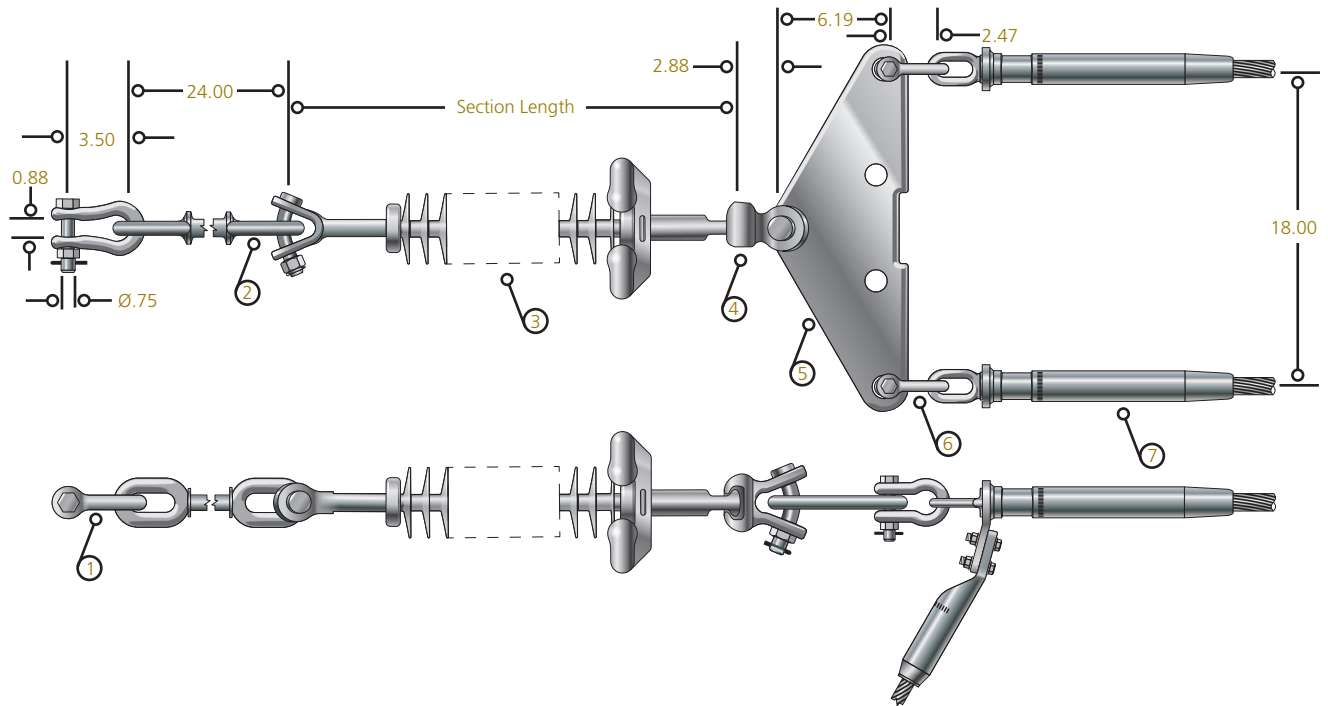

### Base Assembly Catalog Number: TAD-1X-21-50

Item	Part Number	Description	Quantity	Material	UBS lb
1	AS50BNK	Anchor Shackle	1	Forged Steel	60,000
2	H005024	Oval Eye Ext. Link (24")	1	Forged Steel	60,000
3	See Chart	Insulator, ANSI 52-11	1	Polymer	—
4	SYC50	Socket Y-Clevis	1	Ductile Iron	50,000
5	YPD50185491	Yoke Plate	1	Ductile Iron	50,000
6	AS25LBNK	Anchor Shackle	2	Forged Steel	30,000
7	See Note 1	Compression Deadend w/Terminal	2	Aluminum	Full Tension

### Typical Insulator Selection — See Note 2

Line Voltage (kV)	Quadri*Sil® Part Number	Section Length Inches	SML lb	Corona Ring
138	S050043S2010	57.3	50,000	—
161	S050056S2010	70.3	50,000	—
230	S050073S201A	87.6	50,000	8" Line End

**NOTE:** For quoting/ordering instructions, see Assemblies section.

- (1) See Compression Deadends section for standard conductor compression deadend options, See Compression Conventional (Two Die) System section for high temperature conductor compression deadend options.
- (2) See Suspension Insulator section for additional insulator options.

# Deadend, 2-Bundle Conductor

## Double Insulator 30k lb Assembly, TAD-1X-22-30, 138kV - 230kV

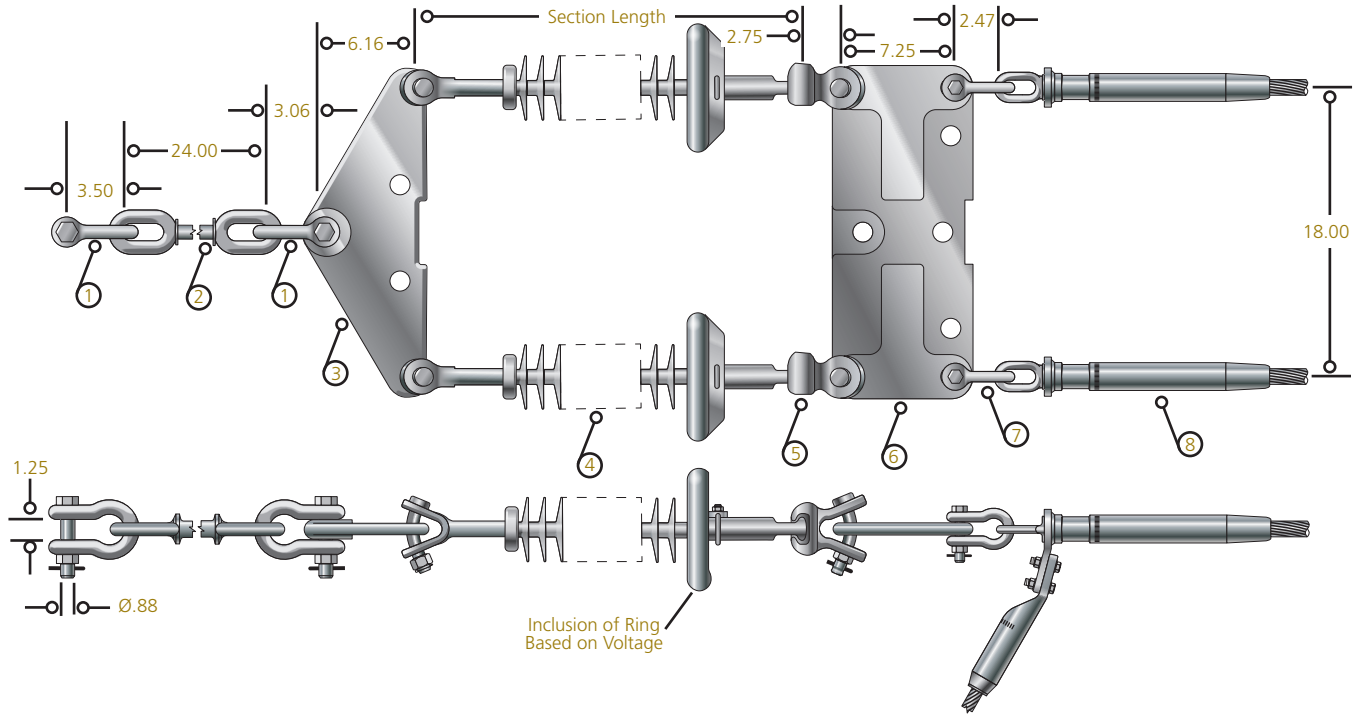

### Base Assembly Catalog Number: TAD-1X-22-30

Item	Part Number	Description	Quantity	Material	UBS lb
1	AS50WBNK	Anchor Shackle	2	Forged Steel	60,000
2	H005024	Oval Eye Ext. Link (24")	1	Forged Steel	60,000
3	YPD60183771	Yoke Plate	1	Ductile Iron	60,000
4	See Chart	Insulator, ANSI 52-5	2	Polymer	—
5	SYC30	Socket Y-Clevis	2	Ductile Iron	30,000
6	YPR30187221	Yoke Plate	1	Ductile Iron	30,000
7	AS25LBNK	Anchor Shackle	2	Forged Steel	30,000
8	See Note 1	Compression Deadend w/Terminal	2	Aluminum	Full Tension

### Typical Insulator Selection — See Note 2

Line Voltage (kV)	Quadri*Sil® Part Number	Section Length Inches	SML lb	Corona Ring
138	S030043S2010	54.9	30,000	—
161	S030056S2010	67.8	30,000	—
230	S030073S201A	85.1	30,000	8" Line End

**NOTE:** For quoting/ordering instructions, see Assemblies section.

- (1) See Compression Deadends section for standard conductor compression deadend options, See Compression Conventional (Two Die) System section for high temperature conductor compression deadend options.
- (2) See Suspension Insulator section for additional insulator options, including 25k lb offerings.

# Deadend, 2-Bundle Conductor

## Double Insulator 50k lb Assembly, TAD-1X-22-50, 138kV - 230kV

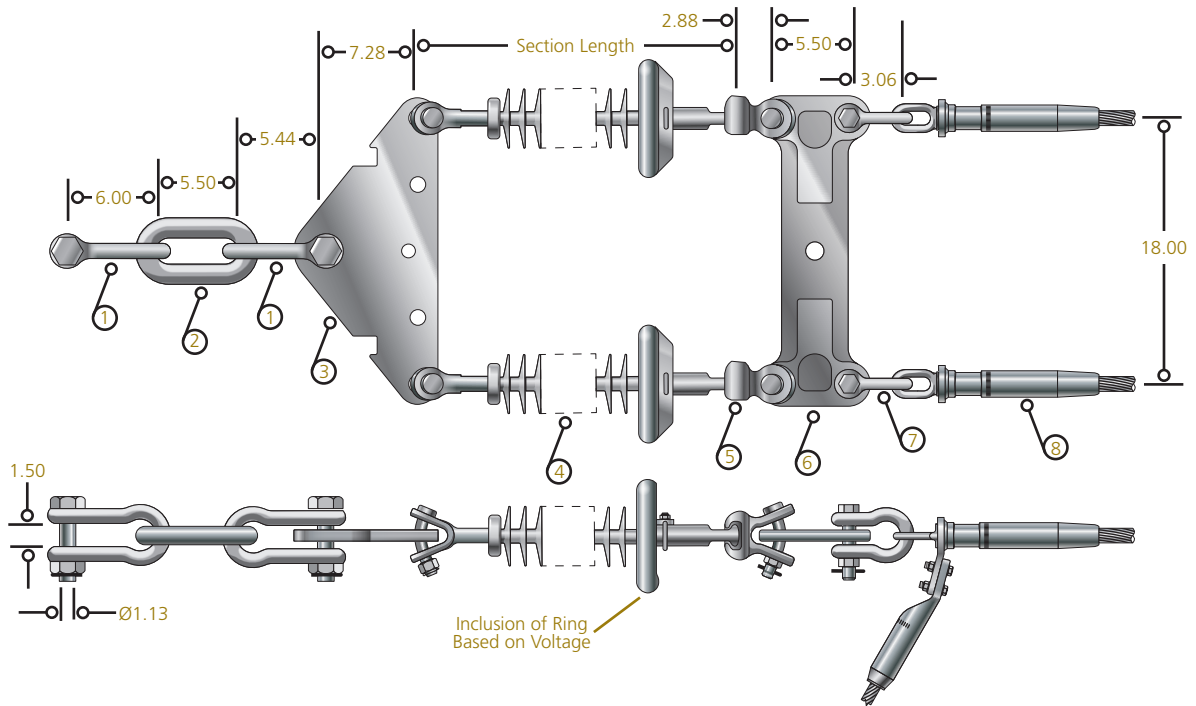

### Base Assembly Catalog Number: TAD-1X-22-50

Item	Part Number	Description	Quantity	Material	UBS lb
1	974153001	Anchor Shackle	2	Forged Steel	120,000
2	LK150	Chain Link	1	Forged Steel	150,000
3	947604006	Yoke Plate	1	Galvanized Steel	100,000
4	See Chart	Insulator, ANSI 52-11	2	Polymer	50,000
5	SYC50	Socket Y-Clevis	2	Ductile Iron	50,000
6	YPR50190508	Yoke Plate	1	Ductile Iron	50,000
7	ASS0WBNK	Anchor Shackle	2	Forged Steel	60,000
8	See Note 1	Compression Deadend w/Terminal	2	Aluminum	Full Tension

### Typical Insulator Selection — See Note 2

Line Voltage (kV)	Quadri*Sil® Part Number	Section Length Inches	SML lb	Corona Ring
138	S050043S2010	57.3	50,000	—
161	S050056S2010	70.3	50,000	—
230	S050073S201A	87.6	50,000	8" Line End

**NOTE:** For quoting/ordering instructions, see Assemblies section.

- (1) See Compression Deadends for standard conductor compression deadend options, See Compression Conventional (Two Die) System section for high temperature conductor compression deadend options.
- (2) See Suspension Insulator section for additional insulator options.

# Jumper Suspension, Single Conductor

## Single Insulator with Weights 30k lb Assembly, TAJ-SX-11-30, 69kV - 230kV

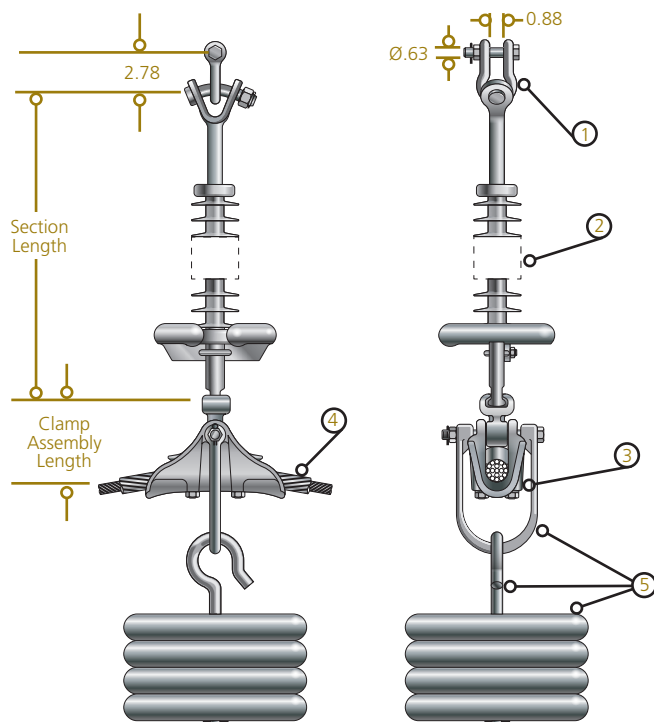

### Base Assembly Catalog Number: TAJ-SX-11-30

Item	Part Number	Description	Quantity	Material	UBS lb
1	AS25LBNK	Anchor Shackle	1	Forged Steel	30,000
2	See Chart	Insulator, ANSI 52-5	1	Polymer	—
3	See Note 1	Suspension Clamp w/Socket	1	Aluminum	—
4	See Note 2	Armor Rods	1	Aluminum	—
5	See Note 4	Hold Down Shackle w/Weights	1	Ductile Iron	10,000

### Typical Insulator Selection — See Note 3

Line Voltage (kV)	Quadri*Sil® Part Number	Section Length Inches	SML lb	Corona Ring
69	S030023S2010	35.4	30,000	—
115	S030036S2010	48.4	30,000	—
138	S030043S2010	54.9	30,000	—
161	S030056S2010	67.8	30,000	—
230	S030073S201A	85.1	30,000	8" Line End

**NOTE:** For quoting/ordering instructions, see Assemblies section.

(1) See Suspension Clamp section for standard and high temperature conductor suspension clamp options.

Contact HPS for armor rod recommendations.

(2) See Suspension Insulator section for additional insulator options, including 25k lb offerings.

(3) See Hardware Fittings section for hold down shackle, weights and hardware options.

# Jumper Support, Single Conductor

## 2.5" Post (Horizontal) Insulator Assembly, TAJ-PX-11-25, 69kV - 230kV

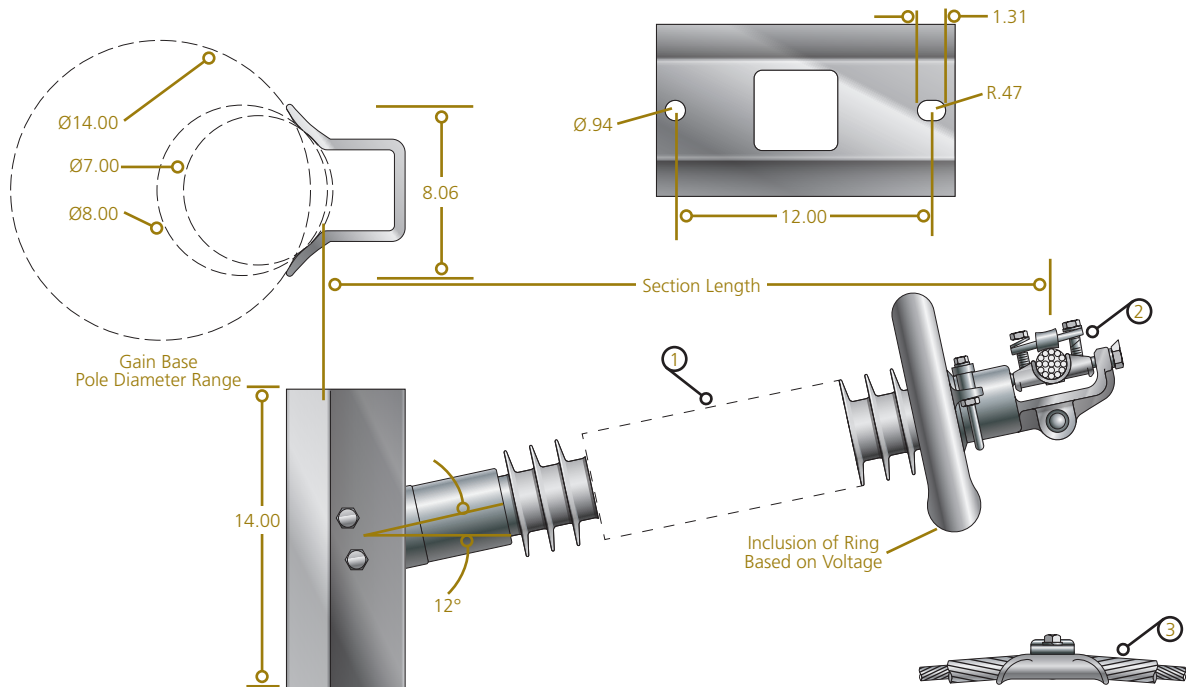

### Base Assembly Catalog Number: TAJ-PX-11-25

Item	Part Number	Description	Quantity	Material	UBS lb
1	See Chart	Insulator Post	1	Polymer	—
2	See Note 1	Trunion Clamp	1	Aluminum	2,800
3	See Note 2	Armor Rods	1	Aluminum	—

### Typical Insulator Selection — See Note 3

Line Voltage (kV)	Quadri*Sil® Part Number	Section Length Inches	RCL lb	Corona Ring
69	P250024S1020	37.7	2,500	—
115	P250036S1020	49.5	1,880	—
138	P250043S1020	56.6	1,600	—
161	P250058S1020	70.8	1,235	—
230	P250070S102A	82.6	1,040	12" Line End

**NOTE:** RCL is 50% of the ultimate cantilever load capacity.

Maximum design tension load rating is 2,500 lb.

For quoting/ordering instructions, see Assemblies section.

- (1) See Suspension Clamp section for standard and high temperature conductor trunion clamp options.
- (2) Contact HPS for armor rod recommendations.
- (3) See Line Post Insulators section for additional insulator options.



# Jumper Support, 2-Bundle Conductor

## 2.5" Post (Horizontal) Insulator Assembly, TAJ-PX-21-25, 138kV - 230kV

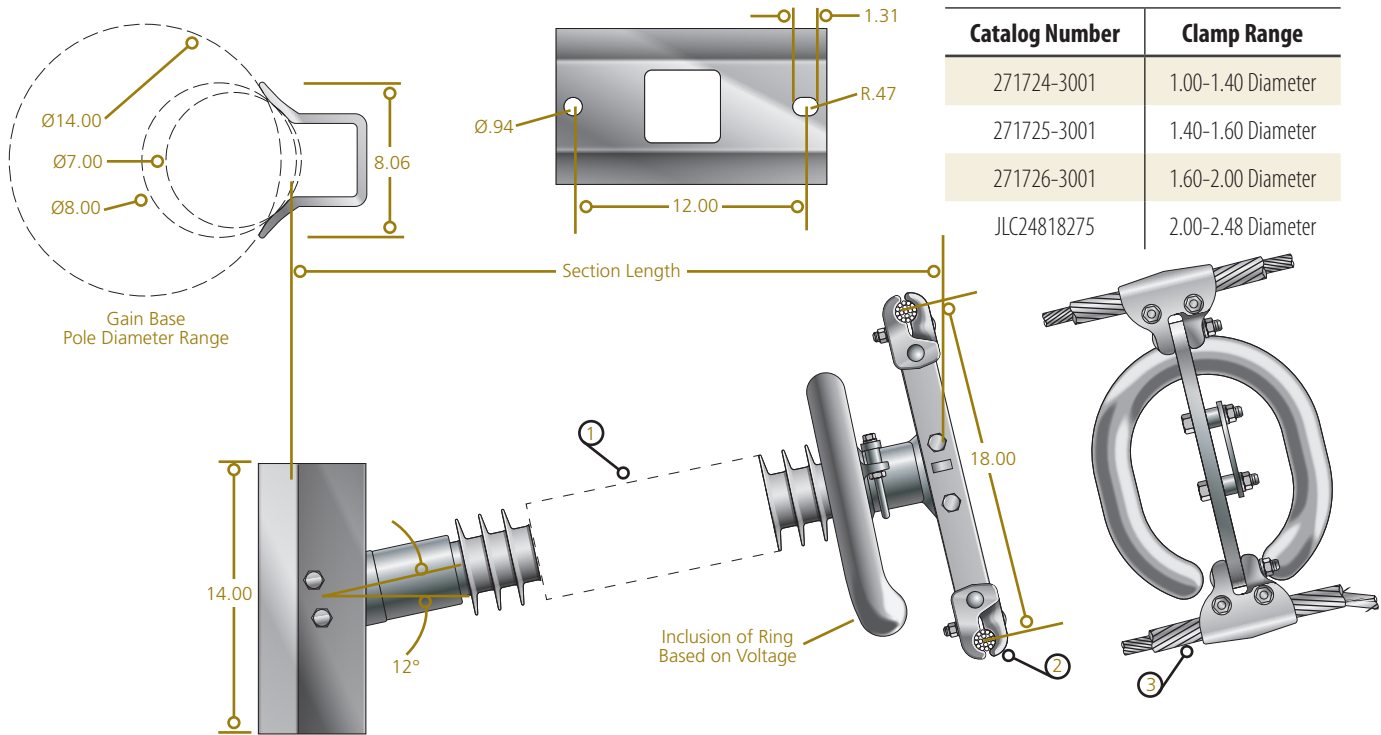

### Jumper Clamp Assembly

Catalog Number	Clamp Range
271724-3001	1.00-1.40 Diameter
271725-3001	1.40-1.60 Diameter
271726-3001	1.60-2.00 Diameter
JLC24818275	2.00-2.48 Diameter

### Base Assembly Catalog Number: TAJ-PX-21-25

Item	Part Number	Description	Quantity	Material	UBS lb
1	See Chart	Insulator, Post	1	Polymer	—
2	See Chart	Jumper Clamp Assembly	1	Steel/Aluminum	5,000
3	See Note 1	Armor Rods	2	Aluminum	—

### Typical Insulator Selection — See Note 2

Line Voltage (kV)	Quadri*Sil® Part Number	Section Length Inches	RCL lb	Corona Ring
138	P250043S0020	55.9	1,625	—
161	P250058S0020	70.1	1,250	—
230	P250070S002A	81.9	1,050	12" Line End

**NOTE:** RCL is 50% of the ultimate cantilever load capacity.  
 Maximum design tension load rating is 7,500 lb.  
 For quoting/ordering instructions, see Assemblies section.

- (1) Contact HPS for armor rod recommendations.
- (2) See Line Post Insulators section for additional insulator options.

# Jumper Support, 2-Bundle Conductor

## 3" Post (Horizontal) Insulator Assembly, TAJ-PX-21-30, 138kV - 230kV

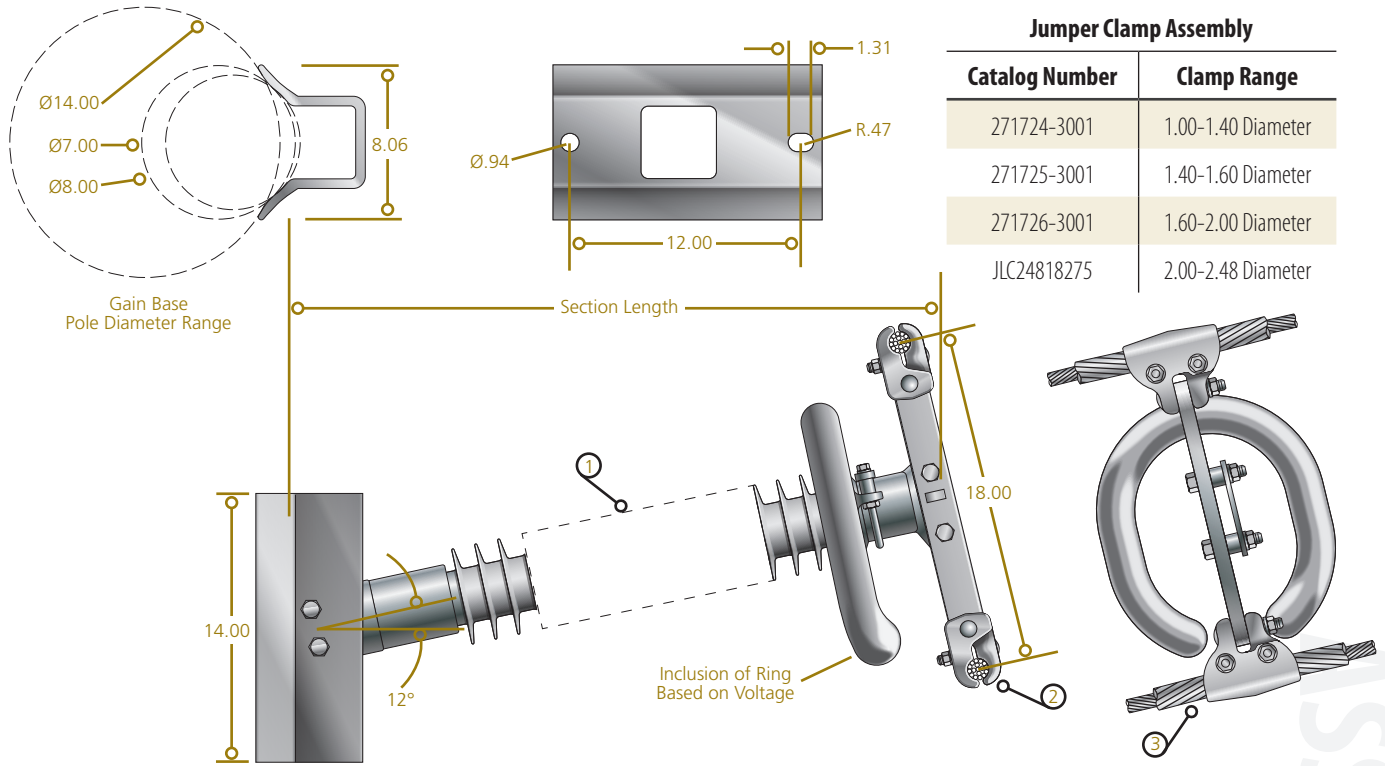

### Base Assembly Catalog Number: TAJ-PX-21-30

Item	Part Number	Description	Quantity	Material	UBS lb
1	See Chart	Insulator, Post	1	Polymer	—
2	See Chart	Jumper Clamp Assembly	1	Steel/Aluminum	5,000
3	See Note 1	Armor Rods	2	Aluminum	—

### Typical Insulator Selection — See Note 2

Line Voltage (kV)	Quadri*Sil® Part Number	Section Length Inches	RCL lb	Corona Ring
138	P300047S0020	59.7	2,635	—
161	P300063S0020	75.0	2,020	—
230	P300074S002A	85.6	1,740	15" Line End

**NOTE:** RCL is 50% of the ultimate cantilever load capacity.  
 Maximum design tension load rating is 12,500 lb.  
 For quoting/ordering instructions, see Assemblies section.

- (1) Contact HPS for armor rod recommendations.
- (2) See Line Post Insulators section for additional insulator options.

# Jumper Support, 2-Bundle Conductor

## Single Insulator with Weights 30k lb Assembly, TAJ-SH-21-30, 138kV - 230kV

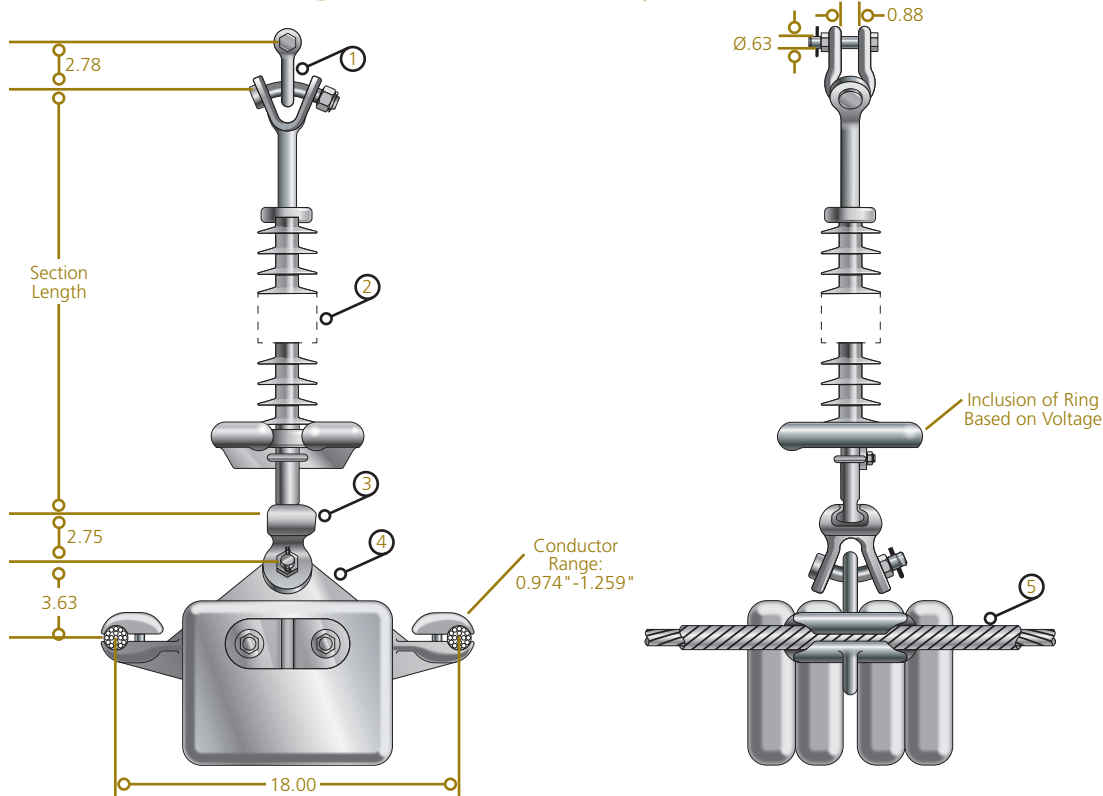

### Base Assembly Catalog Number: TAJ-SH-21-30

Item	Part Number	Description	Quantity	Material	UBS lb
1	AS25LBK	Anchor Shackle	1	Forged Steel	30,000
2	See Chart	Insulator, ANSI 52-5	1	Polymer	—
3	SYC30	Socket Y-Clevis	1	Ductile Iron	30,000
4	YPJ21018215200 See Note 1	Jumper Yoke w/Weights	1	Aluminum	10,000
5	See Note 2	Armor Rods	1	Aluminum	—

### Typical Insulator Selection — See Note 3

Line Voltage (kV)	Quadri*Sil® Part Number	Section Length Inches	SML lb	Corona Ring
138	S030043S2010	54.9	30,000	—
161	S030056S2010	67.8	30,000	—
230	S030073S201A	85.1	30,000	8" Line End

**NOTE:** For quoting/ordering instructions, see Assemblies section.

- (1) For jumper yokes with other conductor ranges or different amounts of weight, please contact HPS.
- (2) Contact HPS for armor rod recommendations.
- (3) See Hardware Fittings section for additional insulator options, including 25k lb offerings.

# Jumper Support, 2-Bundle Conductor

## 2.5" Post (Vertical) Insulator Assembly, TAJ-PH-21-25, 138kV - 230kV

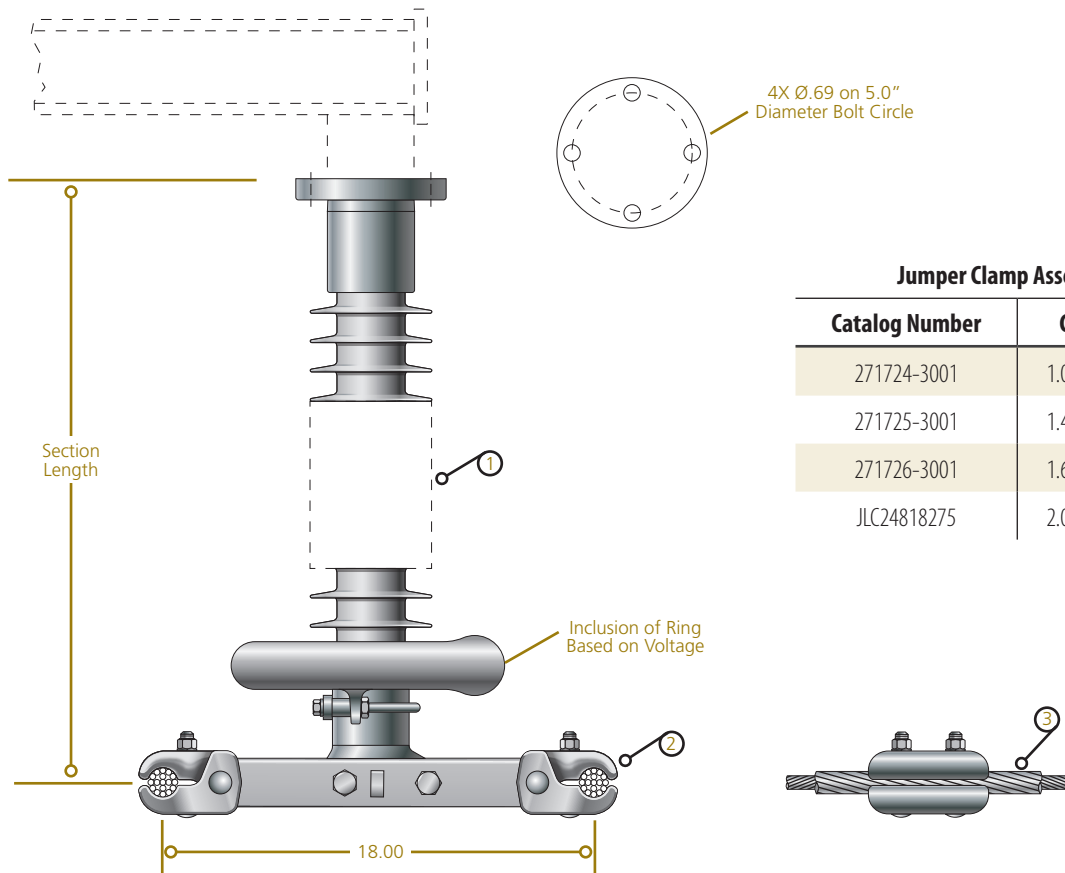

Jumper Clamp Assembly	
Catalog Number	Clamp Range
271724-3001	1.00-1.40 Diameter
271725-3001	1.40-1.60 Diameter
271726-3001	1.60-2.00 Diameter
JLC24818275	2.00-2.48 Diameter

### Base Assembly Catalog Number: TAJ-PH-21-25

Item	Part Number	Description	Quantity	Material	UBS lb
1	See Chart	Insulator Post	1	Polymer	—
2	See Chart	Jumper Clamp Assembly	1	Steel/ Aluminum	5,000
3	See Note 1	Armor Rods	2	Aluminum	—

### Typical Insulator Selection — See Note 2

Line Voltage (kV)	Quadri*Sil® Part Number	Section Length Inches	RCL lb	Corona Ring
138	P250043S5300	53.2	1,625	—
161	P250058S5300	67.8	1,250	—
230	P250070S530A	79.8	1,050	12" Line End

**NOTE:** RCL is 50% of the ultimate cantilever load capacity.  
 Maximum design tension load rating is 7,500 lb.  
 For quoting/ordering instructions, see Assemblies section.

- (1) Contact HPS for armor rod recommendations.
- (2) See Line Post Insulators section for additional insulator options.

# EHV Tangent Suspension, 2-Bundle Conductor

## Single-String 30k lb Assembly, TET-IH-21-30, 230kV - 345kV

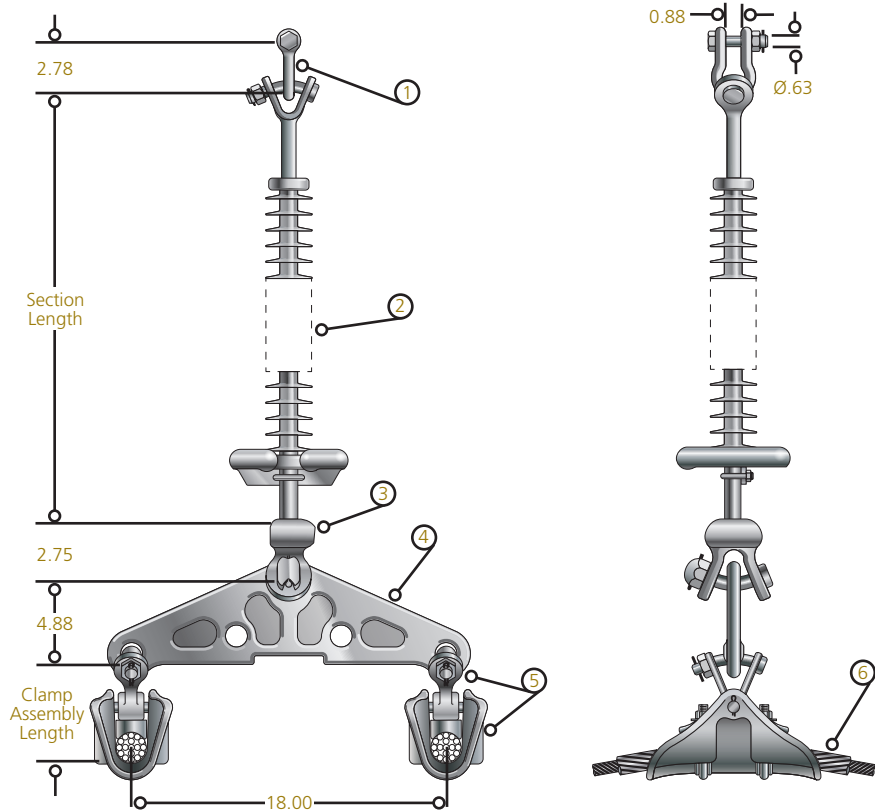

### Base Assembly Catalog Number: TET-IH-21-30

Item	Part Number	Description	Quantity	Material	UBS lb
1	AS25LBNK	Anchor Shackle	1	Forged Steel	30,000
2	See Chart	Insulator, ANSI 52-5	1	Polymer	—
3	SYC30SN	Socket Y-Clevis	1	Ductile Iron	30,000
4	YPD30184373	Yoke Plate	1	Ductile Iron	30,000
5	See Note 1	Suspension Clamp w/Y-Clevis Eye	2	Aluminum	—
6	See Note 2	Armor Rods	2	Aluminum	—

### Typical Insulator Selection — See Note 3

Line Voltage (kV)	Quadri*Sil® Part Number	Section Length Inches	SML lb	Corona Ring
230	S030073S201A	85.1	30,000	8" Line End
345	S030103S201B	115.3	30,000	12" Line End

- NOTE:** For quoting/ordering instructions, see Assemblies section.
- (1) See Suspension Clamp section for standard and high temperature conductor suspension clamp options.
  - (2) Contact HPS for armor rod recommendations.
  - (3) See Suspension Insulator section for additional insulator options.



# EHV Tangent Suspension, 2-Bundle Conductor

## Single-String 50k lb Assembly, TET-IH-21-50, 230kV - 345kV

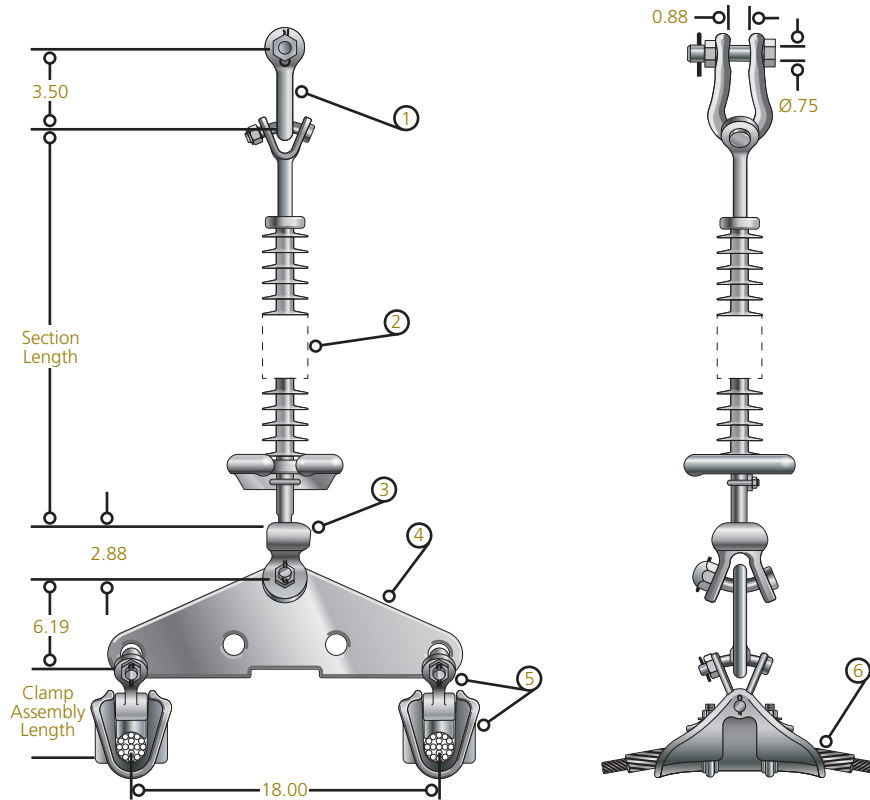

### Base Assembly Catalog Number: TET-IH-21-50

Item	Part Number	Description	Quantity	Material	UBS lb
1	AS50BNK	Anchor Shackle	1	Forged Steel	60,000
2	See Chart	Insulator, ANSI 52-11	1	Polymer	—
3	SYC50SN	Socket Y-Clevis	1	Ductile Iron	50,000
4	YPD50185491	Yoke Plate	1	Ductile Iron	50,000
5	See Note 1	Suspension Clamp w/Y-Clevis Eye	2	Aluminum	—
6	See Note 2	Armor Rods	2	Aluminum	—

### Typical Insulator Selection — See Note 3

Line Voltage (kV)	Quadri*Sil® Part Number	Section Length Inches	SML lb	Corona Ring
230	S050073S201A	87.6	50,000	8" Line End
345	S050103S201B	117.8	50,000	12" Line End

**NOTE:** For quoting/ordering instructions, see Assemblies section.

- (1) See Suspension Clamp section for standard and high temperature conductor suspension clamp options.
- (2) Contact HPS for armor rod recommendations.
- (3) See Suspension Insulator section for additional insulator options.

# EHV Tangent Suspension, 2-Bundle Conductor

## V-String 30k lb Assembly, TET-VH-22-30, 230kV - 345kV

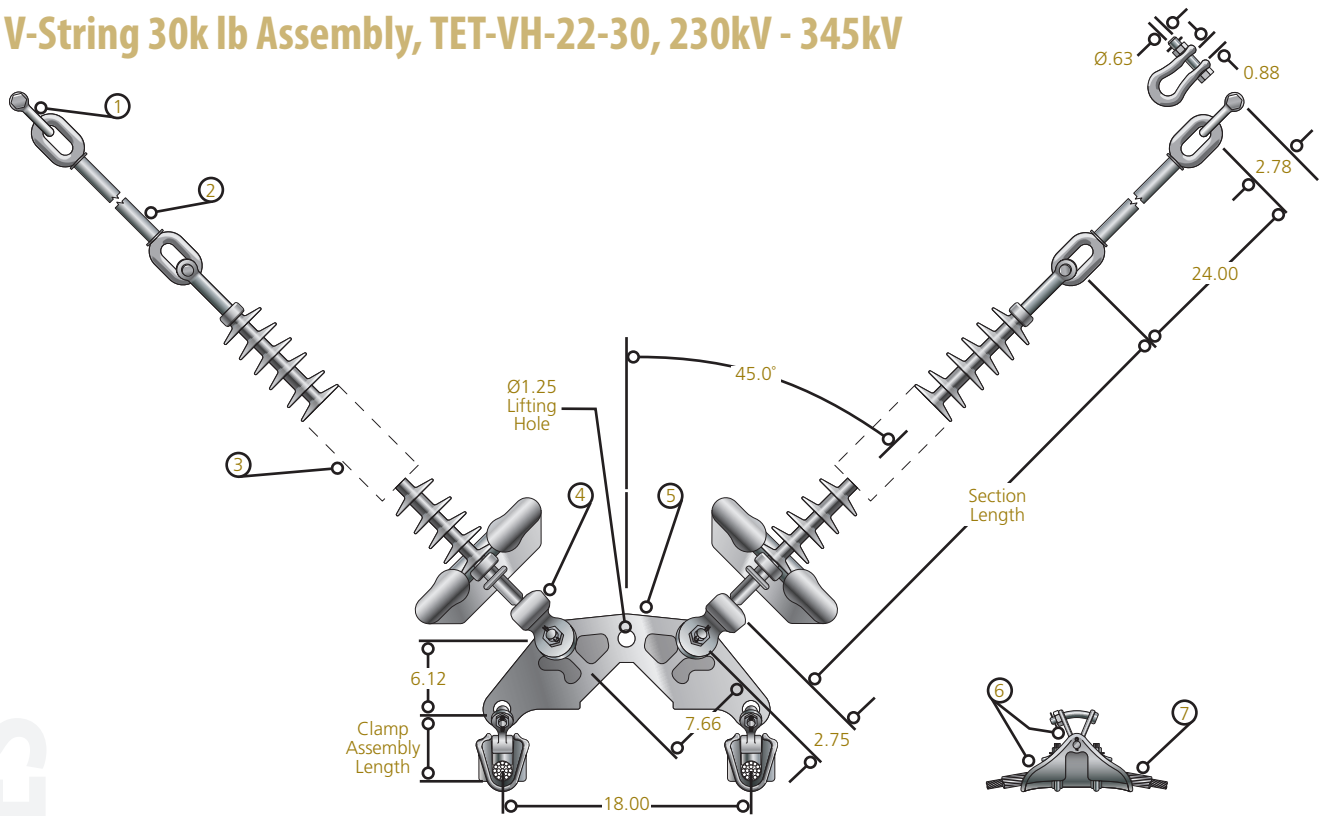

### Base Assembly Catalog Number: TET-VH-22-30

Item	Part Number	Description	Quantity	Material	UBS lb
1	AS25LBNK	Anchor Shackle	2	Forged Steel	30,000
2	H003024	Oval Eye Ext. Link (24")	2	Forged Steel	30,000
3	See Chart	Insulator, ANSI 52-5	2	Polymer	—
4	SYC30SN	Socket Y-Clevis	2	Ductile Iron	30,000
5	YPV30172592	Yoke Plate	1	Ductile Iron	30,000
6	See Note 1	Suspension Clamp w/Y-Clevis Eye	2	Aluminum	—
7	See Note 2	Armor Rods	2	Aluminum	—

### Typical Insulator Selection — See Note 3

Line Voltage (kV)	Quadri*Sil® Part Number	Section Length Inches	SML lb	Corona Ring
230	S030073S201A	85.1	30,000	8" Line End
345	S030103S201B	115.3	30,000	12" Line End

**NOTE:** For quoting/ordering instructions, see Assemblies section.

- (1) See Suspension Clamp section for standard and high temperature conductor suspension clamp options.
- (2) Contact HPS for armor rod recommendations.
- (3) See Suspension Insulator section for additional insulator options.

# EHV Tangent Suspension, 2-Bundle Conductor

## V-String 50k lb Assembly, TET-VH-22-50, 230kV - 345kV

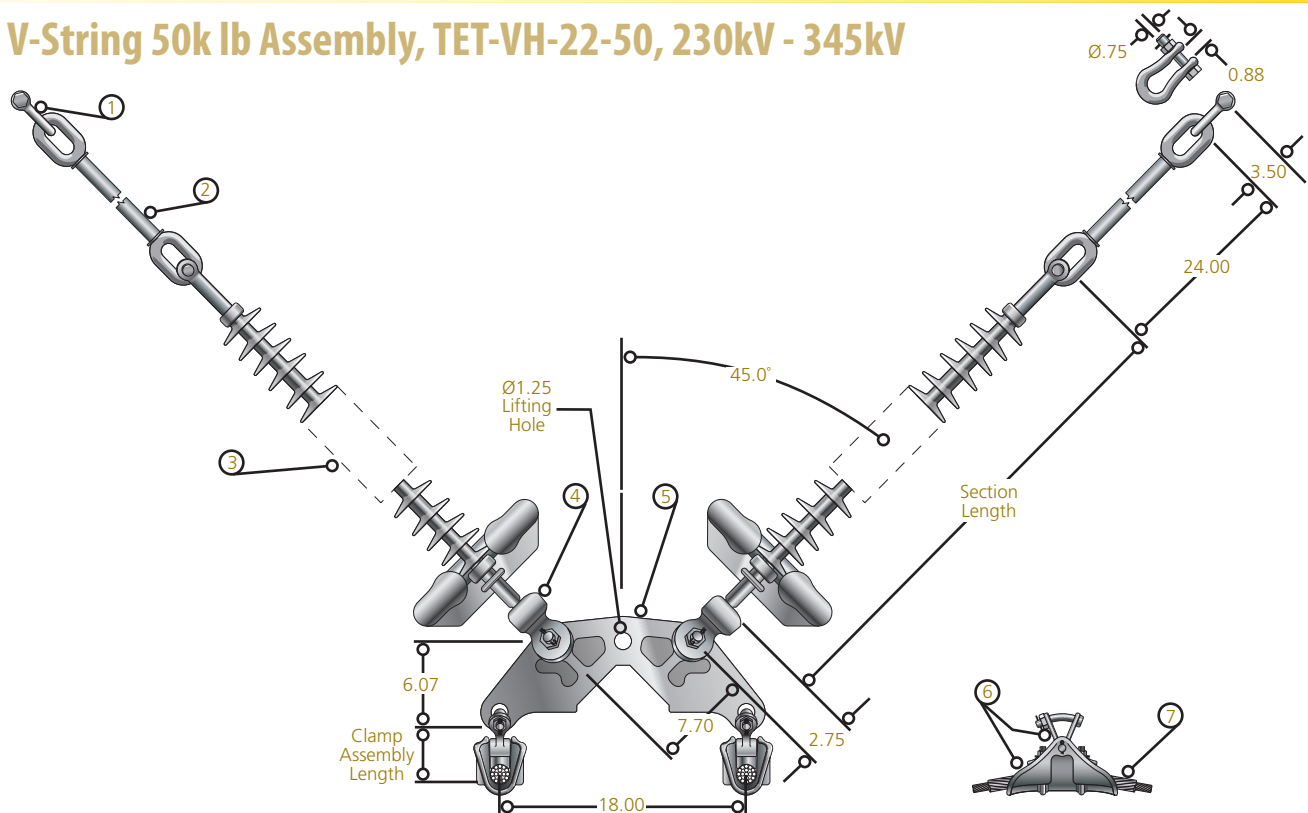

### Base Assembly Catalog Number: TET-VH-22-50

Item	Part Number	Description	Quantity	Material	UBS lb
1	AS50BNK	Anchor Shackle	2	Forged Steel	60,000
2	H005024	Oval Eye Ext. Link (24")	2	Forged Steel	60,000
3	See Chart	Insulator, ANSI 52-11	2	Polymer	—
4	SYCS0SN	Socket Y-Clevis	2	Ductile Iron	50,000
5	YPV5019011	Yoke Plate	1	Ductile Iron	50,000
6	See Note 1	Suspension Clamp w/Y-Clevis Eye	2	Aluminum	—
7	See Note 2	Armor Rods	2	Aluminum	—

### Typical Insulator Selection — See Note 3

Line Voltage (kV)	Quadri*Sil® Part Number	Section Length Inches	SML lb	Corona Ring
230	S050073S201A	87.6	50,000	8" Line End
345	S050103S201B	117.8	50,000	12" Line End

**NOTE:** For quoting/ordering instructions, see Assemblies section.

- (1) See Suspension Clamp section for standard and high temperature conductor suspension clamp options.
- (2) Contact HPS for armor rod recommendations.
- (3) See Suspension Insulator section for additional insulator options.

# EHV Tangent Suspension, 3-Bundle Conductor

## V-String 30k lb Assembly, TET-VX-32-30, 345kV - 500kV

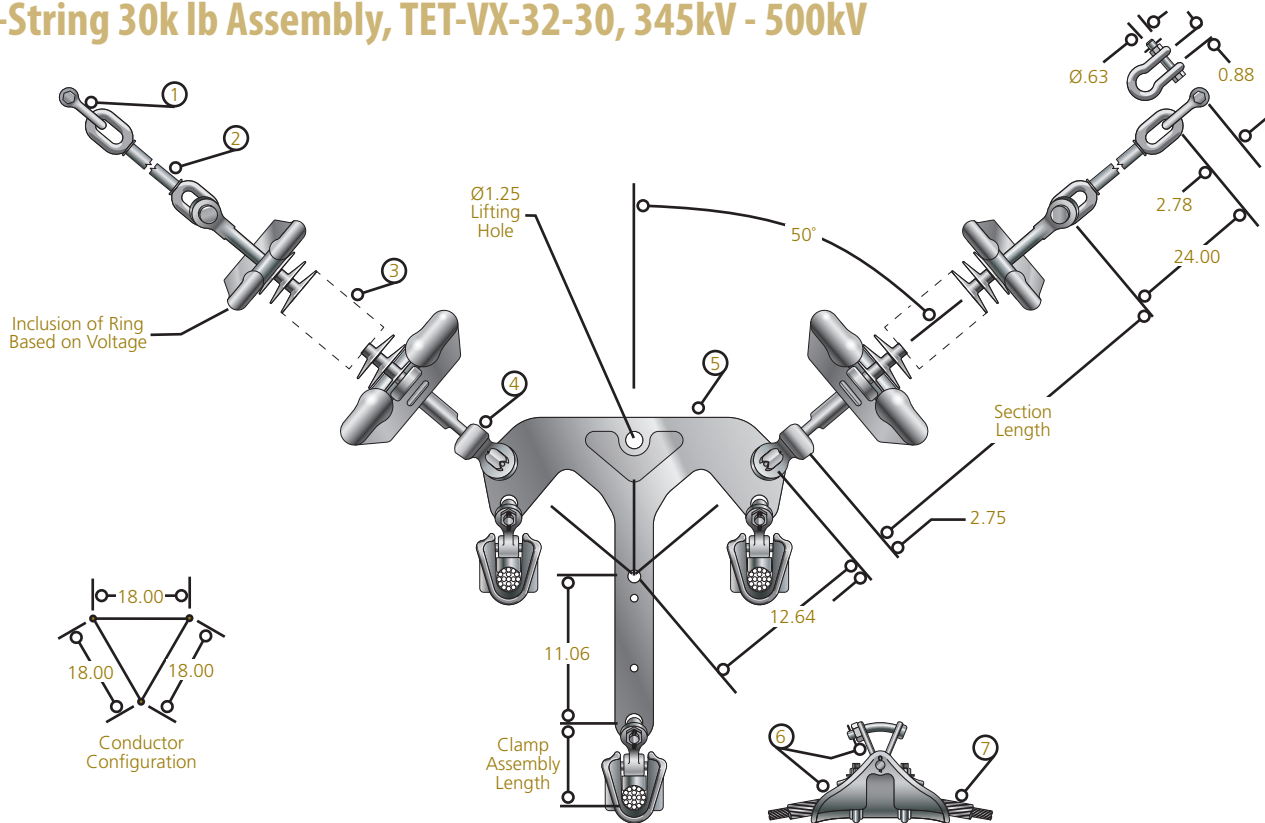

### Base Assembly Catalog Number: TET-VX-32-30

Item	Part Number	Description	Quantity	Material	UBS lb
1	AS25LBNK	Anchor Shackle	2	Forged Steel	30,000
2	H003024	Oval Eye Ext. Link (24")	2	Forged Steel	30,000
3	See Chart	Insulator, ANSI 52-5	2	Polymer	—
4	SYC30SN	Socket Y-Clevis	2	Ductile Iron	30,000
5	YPT40236673	Yoke Plate	1	Ductile Iron	40,000
6	See Note 1	Suspension Clamp w/Y-Clevis Eye	3	Aluminum	—
7	See Note 2	Armor Rods	3	Aluminum	—

### Typical Insulator Selection — See Note 3

Line Voltage (kV)	Quadri*Sil® Part Number	Section Length Inches	SML lb	Corona Ring
345	S030103S201B	115.3	50,000	12" Line End
500	S030155S201D	167.2	50,000	15" Line End 8" Ground End

**NOTE:** For quoting/ordering instructions, see Assemblies section.

- (1) See Suspension Clamp section for standard and high temperature conductor suspension clamp options.
- (2) Contact HPS for armor rod recommendations.
- (3) See Suspension Insulator section for additional insulator options.

# EHV Tangent Suspension, 3-Bundle Conductor

## V-String 50k lb Assembly, TET-VX-32-50, 345kV - 500kV

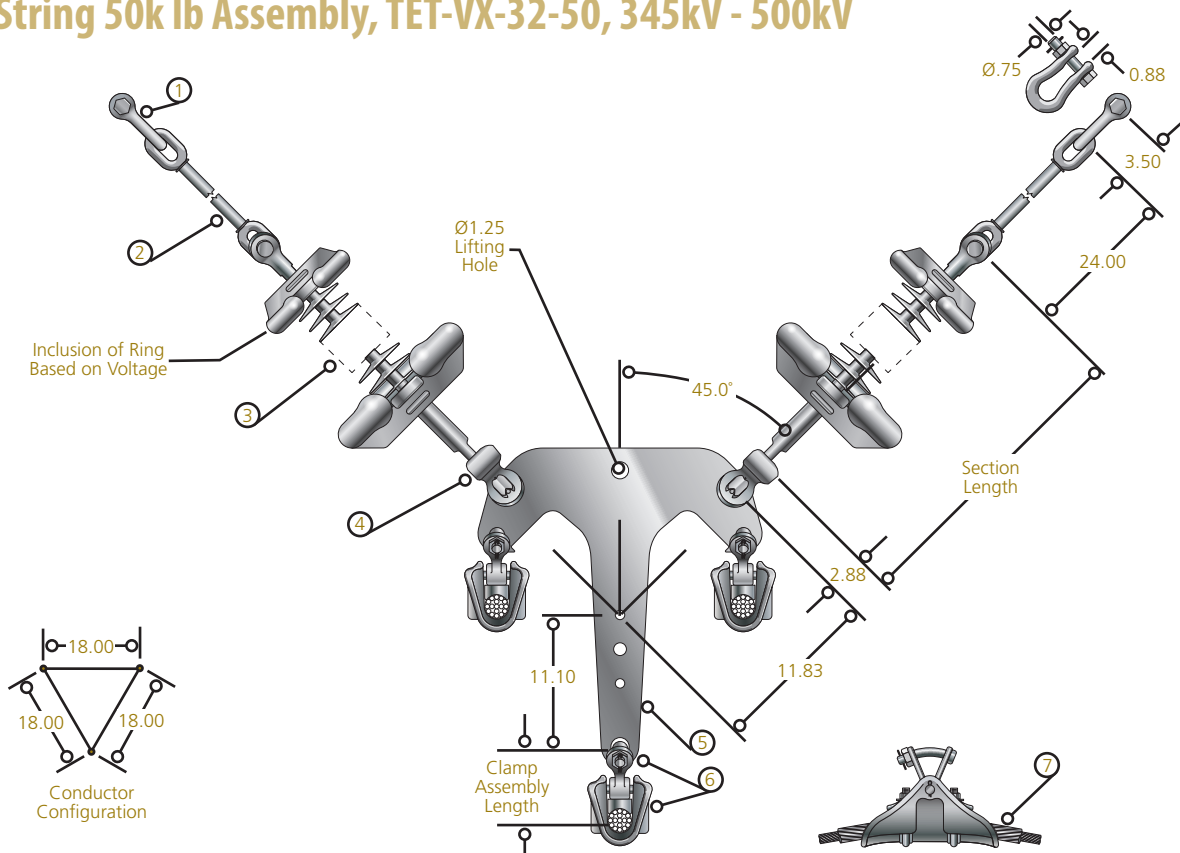

### Base Assembly Catalog Number: TET-VX-32-50

Item	Part Number	Description	Quantity	Material	UBS lb
1	AS50BNK	Anchor Shackle	2	Forged Steel	60,000
2	H005024	Oval Eye Ext. Link (24")	2	Forged Steel	60,000
3	See Chart	Insulator, ANSI 52-11	2	Polymer	—
4	SYC50SN	Socket Y-Clevis	2	Ductile Iron	50,000
5	YPT5012512	Yoke Plate	1	Galvanized Steel	50,000
6	See Note 1	Suspension Clamp w/Y-Clevis Eye	3	Aluminum	—
7	See Note 2	Armor Rods	3	Aluminum	—

### Typical Insulator Selection — See Note 3

Line Voltage (kV)	Quadri*Sil® Part Number	Section Length Inches	SML lb	Corona Ring
345	S050103S201B	117.8	50,000	12" Line End
500	S050155S201D	169.6	50,000	15" Line End 8" Ground End

**NOTE:** For quoting/ordering instructions, see Assemblies section.

- (1) See Suspension Clamp section for standard and high temperature conductor suspension clamp options.
- (2) Contact HPS for armor rod recommendations.
- (3) See Suspension Insulator section for additional insulator options.



# EHV Tangent Suspension, 3-Bundle Conductor

## V-String 80k lb Assembly, TET-VX-32-80, 345kV - 500kV

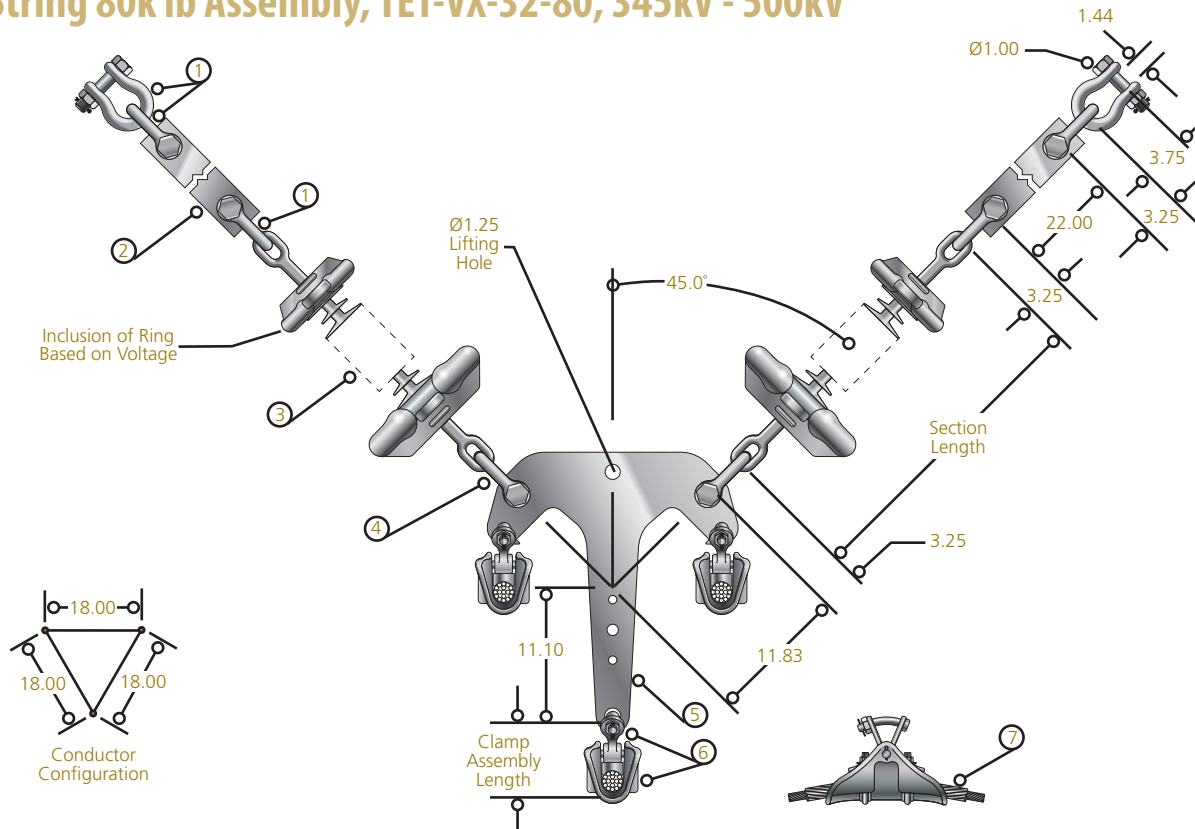

### Base Assembly Catalog Number: TET-VX-32-80

Item	Part Number	Description	Quantity	Material	UBS lb
1	AS60BNK	Anchor Shackle	6	Forged Steel	80,000
2	ES80781921	Extension Strap (21")	2	Galvanized Steel	80,000
3	See Chart	Insulator, Eye-Eye	2	Polymer	—
4	AS60BNKSN	Anchor Shackle	2	Forged Steel	80,000
5	YPT8013055	Yoke Plate	1	Galvanized Steel	80,000
6	See Note 1	Suspension Clamp w/Y-Clevis Eye	3	Aluminum	—
7	See Note 2	Armor Rods	3	Aluminum	—

### Typical Insulator Selection — See Note 3

Line Voltage (kV)	Quadri*Sil® Part Number	Section Length Inches	SML lb	Corona Ring
345	S080103H000B	124.5	80,000	12" Line End
500	S080155H000D	176.3	80,000	15" Line End 8" Ground End

**NOTE:** For quoting/ordering instructions, see Assemblies section.

- (1) See Suspension Clamp section for standard and high temperature conductor suspension clamp options.
- (2) Contact HPS for armor rod recommendations.
- (3) See Suspension Insulator section for additional insulator options.

# EHV Tangent Suspension, 3-Bundle Conductor

## Double V-String 50k lb Assembly, TET-DX-34-50, 345kV - 500kV

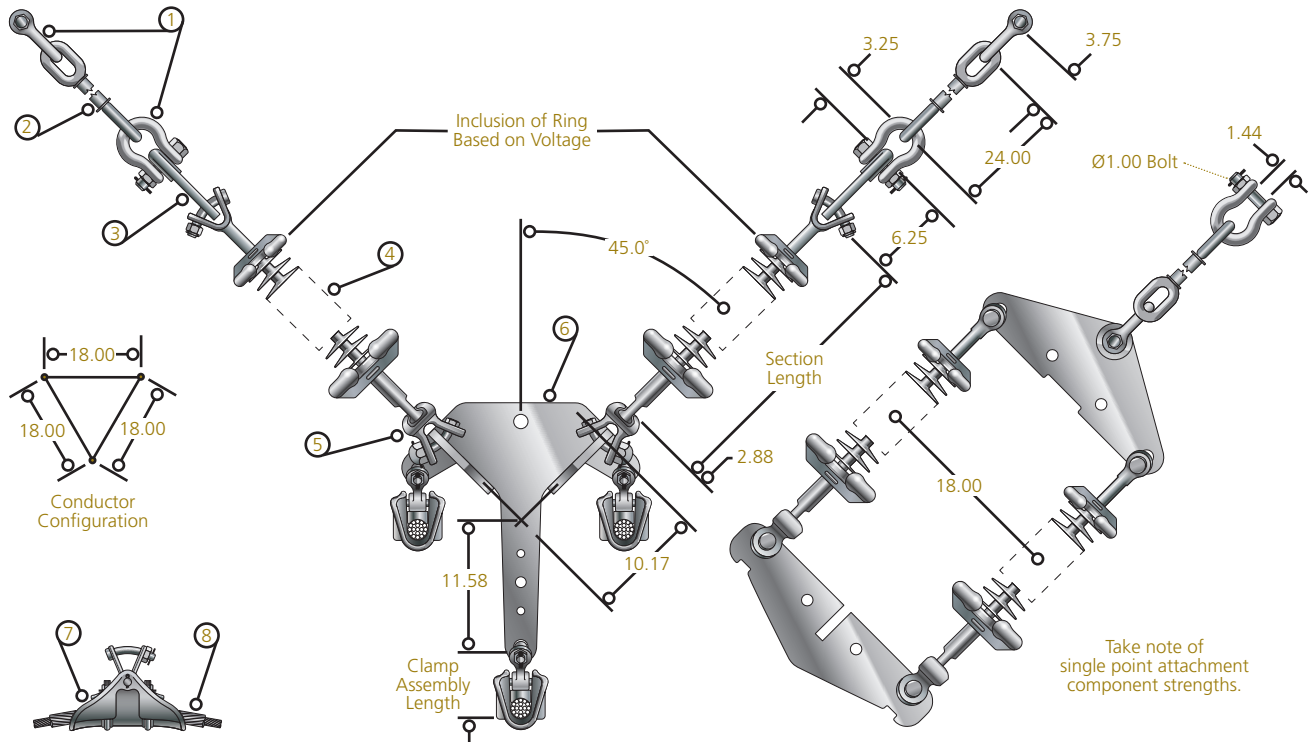

### Base Assembly Catalog Number: TET-DX-34-50

Item	Part Number	Description	Quantity	Material	UBS lb
1	AS60BNK	Anchor Shackle	4	Forged Steel	80,000
2	HOOT8024	Oval Eye Ext. Link (24")	2	Forged Steel	80,000
3	YPD8018475	Yoke Plate	2	Ductile Iron	80,000
4	See Chart	Insulator, ANSI 52-11	4	Polymer	—
5	SYC50SN	Socket Y-Clevis	4	Ductile Iron	50,000
6	YPTB40114896	Yoke Plate	1	Galvanized Steel	40,000
7	See Note 1	Suspension Clamp w/Y-Clevis Eye	3	Aluminum	—
8	See Note 2	Armor Rods	3	Aluminum	—

### Typical Insulator Selection — See Note 3

Line Voltage (kV)	Quadri*Sil® Part Number	Section Length Inches	SML lb	Corona Ring
345	S050103S201B	117.8	50,000	12" Line End
500	S050155S201D	169.6	50,000	15" Line End 8" Ground End

**NOTE:** For quoting/ordering instructions, see Assemblies section.

- (1) See Suspension Clamp section for standard and high temperature conductor suspension clamp options.
- (2) Contact HPS for armor rod recommendations.
- (3) See Suspension Insulator section for additional insulator options.

# EHV Angle Suspension, 2-Bundle Conductor

## Running Angle 30k lb Assembly, TEA-IH-21-30, 230kV - 345kV

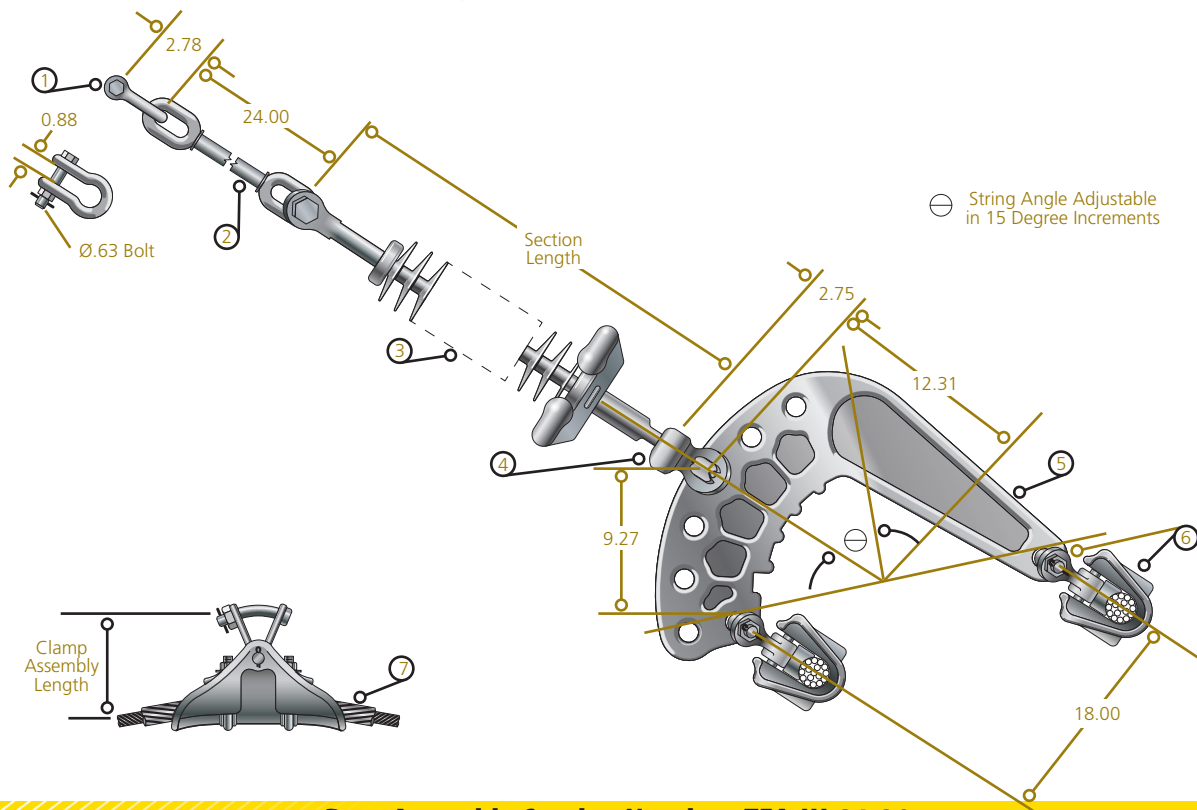

### Base Assembly Catalog Number: TEA-IH-21-30

Item	Part Number	Description	Quantity	Material	UBS lb
1	AS25LBNK	Anchor Shackle	1	Forged Steel	30,000
2	H003024	Oval Eye Ext. Link (24")	1	Forged Steel	30,000
3	See Chart	Insulator, ANSI 52-5	1	Polymer	—
4	SYC30SN	Socket Y-Clevis	1	Ductile Iron	30,000
5	YPC5026001	Yoke Plate	1	Ductile Iron	50,000
6	See Note 1	Suspension Clamp w/Y-Clevis Eye	2	Aluminum	—
7	See Note 2	Armor Rods	2	Aluminum	—

### Typical Insulator Selection — See Note 3

Line Voltage (kV)	Quadri*Sil® Part Number	Section Length Inches	SML lb	Corona Ring
230	S030073S201A	85.1	30,000	8" Line End
345	S030103S201B	115.3	30,000	12" Line End

**NOTE:** For quoting/ordering instructions, see Assemblies section.

- (1) See Suspension Clamp section for standard and high temperature conductor suspension clamp options.
- (2) Contact HPS for armor rod recommendations.
- (3) See Suspension Insulator section for additional insulator options.

# EHV Angle Suspension, 2-Bundle Conductor

## Running Angle 50k lb Assembly, TEA-IH-21-50, 230kV - 345kV

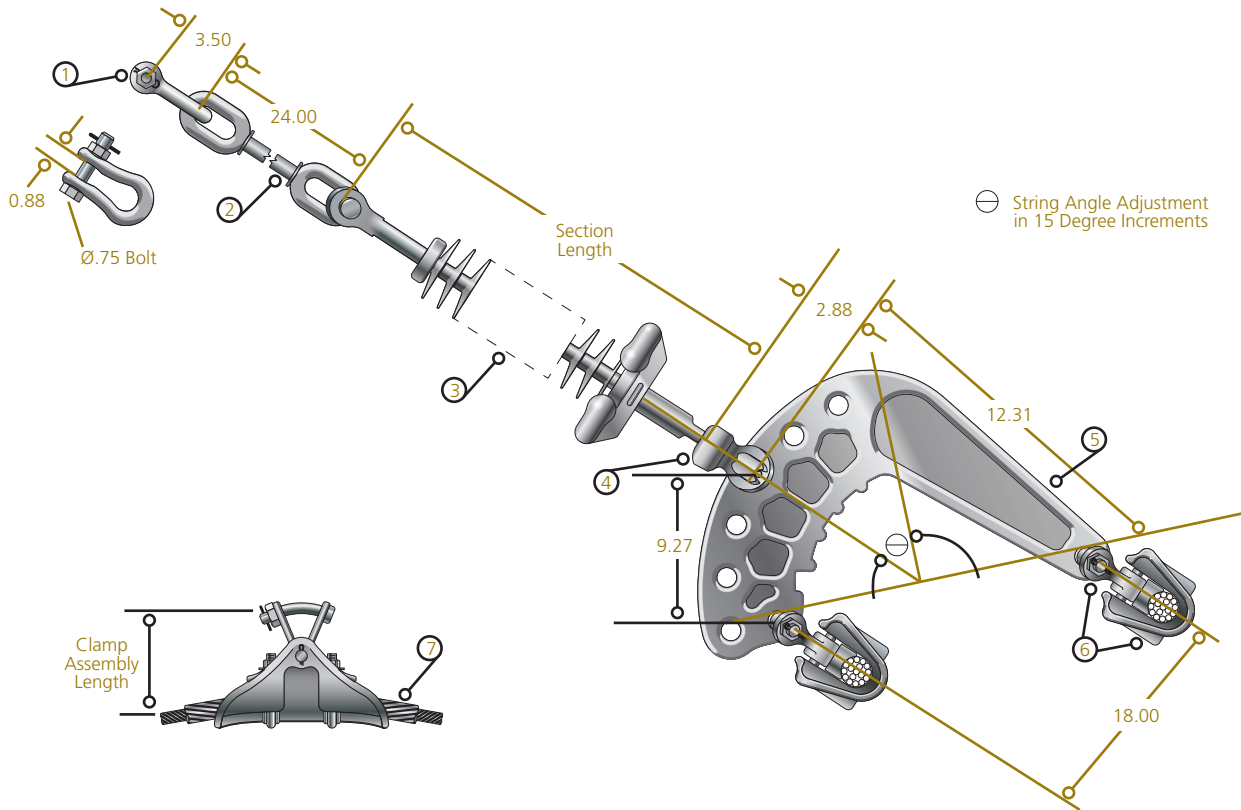

### Base Assembly Catalog Number: TEA-IH-21-50

Item	Part Number	Description	Quantity	Material	UBS lb
1	ASS0BNK	Anchor Shackle	1	Forged Steel	60,000
2	H005024	Oval Eye Ext. Link (24")	1	Forged Steel	60,000
3	See Chart	Insulator, ANSI 52-11	1	Polymer	—
4	SYC50SN	Socket Y-Clevis	1	Ductile Iron	50,000
5	YPC5026001	Yoke Plate	1	Ductile Iron	50,000
6	See Note 1	Suspension Clamp w/Y-Clevis Eye	2	Aluminum	—
7	See Note 2	Armor Rods	2	Aluminum	—

### Typical Insulator Selection — See Note 3

Line Voltage (kV)	Quadri*Sil® Part Number	Section Length Inches	SML lb	Corona Ring
230	S050073S201A	87.6	50,000	8" Line End
345	S050103S201B	117.8	50,000	12" Line End

**NOTE:** For quoting/ordering instructions, see Assemblies section.

- (1) See Suspension Clamp section for standard and high temperature conductor suspension clamp options.
- (2) Contact HPS for armor rod recommendations.
- (3) See Suspension Insulator section for additional insulator options.

# EHV Angle Suspension, 2-Bundle Conductor

## Angle V 30k lb Assembly, TEA-VH-22-30, 230kV - 345kV

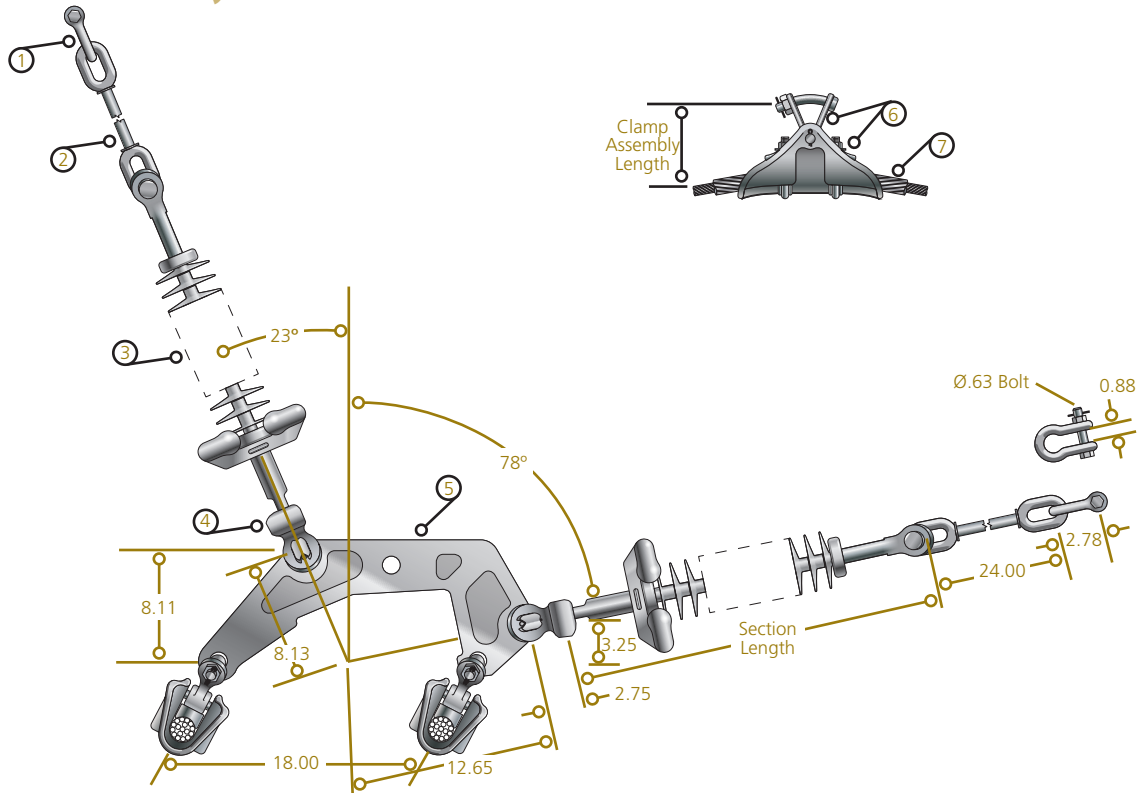

### Base Assembly Catalog Number: TEA-VH-22-30

Item	Part Number	Description	Quantity	Material	UBS lb
1	AS25LBNK	Anchor Shackle	2	Forged Steel	30,000
2	H003024	Oval Eye Ext. Link (24")	2	Forged Steel	30,000
3	See Chart	Insulator, ANSI 52-5	2	Polymer	—
4	SYC30SN	Socket Y-Clevis	2	Ductile Iron	30,000
5	YPC30174241	Yoke Plate	1	Ductile Iron	30,000
6	See Note 1	Suspension Clamp w/Y-Clevis Eye	2	Aluminum	—
7	See Note 2	Armor Rods	2	Aluminum	—

### Typical Insulator Selection — See Note 3

Line Voltage (kV)	Quadri*Sil® Part Number	Section Length Inches	SML lb	Corona Ring
230	S030073S201A	85.1	30,000	8" Line End
345	S030103S201B	115.3	30,000	12" Line End

**NOTE:** For quoting/ordering instructions, see Assemblies section.

- (1) See Suspension Clamp section for standard and high temperature conductor suspension clamp options.
- (2) Contact HPS for armor rod recommendations.
- (3) See Suspension Insulator section for additional insulator options.



# EHV Angle Suspension, 2-Bundle Conductor

## Angle V 50k lb Assembly, TEA-VH-22-50, 230kV - 345kV

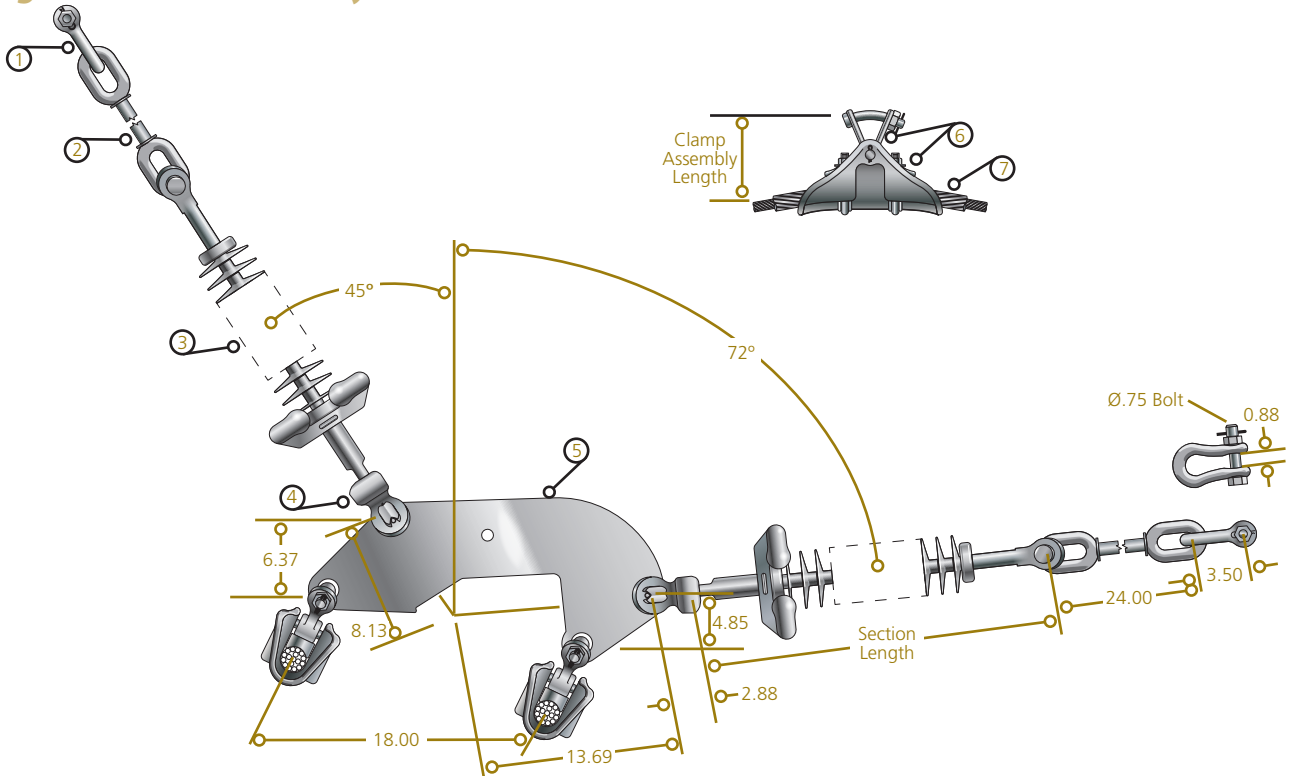

**Base Assembly Catalog Number: TEA-VH-22-50**

Item	Part Number	Description	Quantity	Material	UBS lb
1	AS50BNK	Anchor Shackle	2	Forged Steel	60,000
2	H005024	Oval Eye Ext. Link (24")	2	Forged Steel	60,000
3	See Chart	Insulator, ANSI 52-11	2	Polymer	—
4	SYC50SN	Socket Y-Clevis	2	Ductile Iron	50,000
5	945834005	Yoke Plate	1	Galvanized Steel	50,000
6	See Note 1	Suspension Clamp w/Y-Clevis Eye	2	Aluminum	—
7	See Note 2	Armor Rods	2	Aluminum	—

### Typical Insulator Selection — See Note 3

Line Voltage (kV)	Quadri*Sil® Part Number	Section Length Inches	SML lb	Corona Ring
230	S050073S201A	87.6	50,000	8" Line End
345	S050103S201B	117.8	50,000	12" Line End

**NOTE:** For quoting/ordering instructions, see Assemblies section.

- (1) See Suspension Clamp section for standard and high temperature conductor suspension clamp options.
- (2) Contact HPS for armor rod recommendations.
- (3) See Suspension Insulator section for additional insulator options.

# EHV Angle Suspension, 3-Bundle Conductor

## Angle V 50k lb Assembly, TEA-VX-32-50, 345kV - 500kV

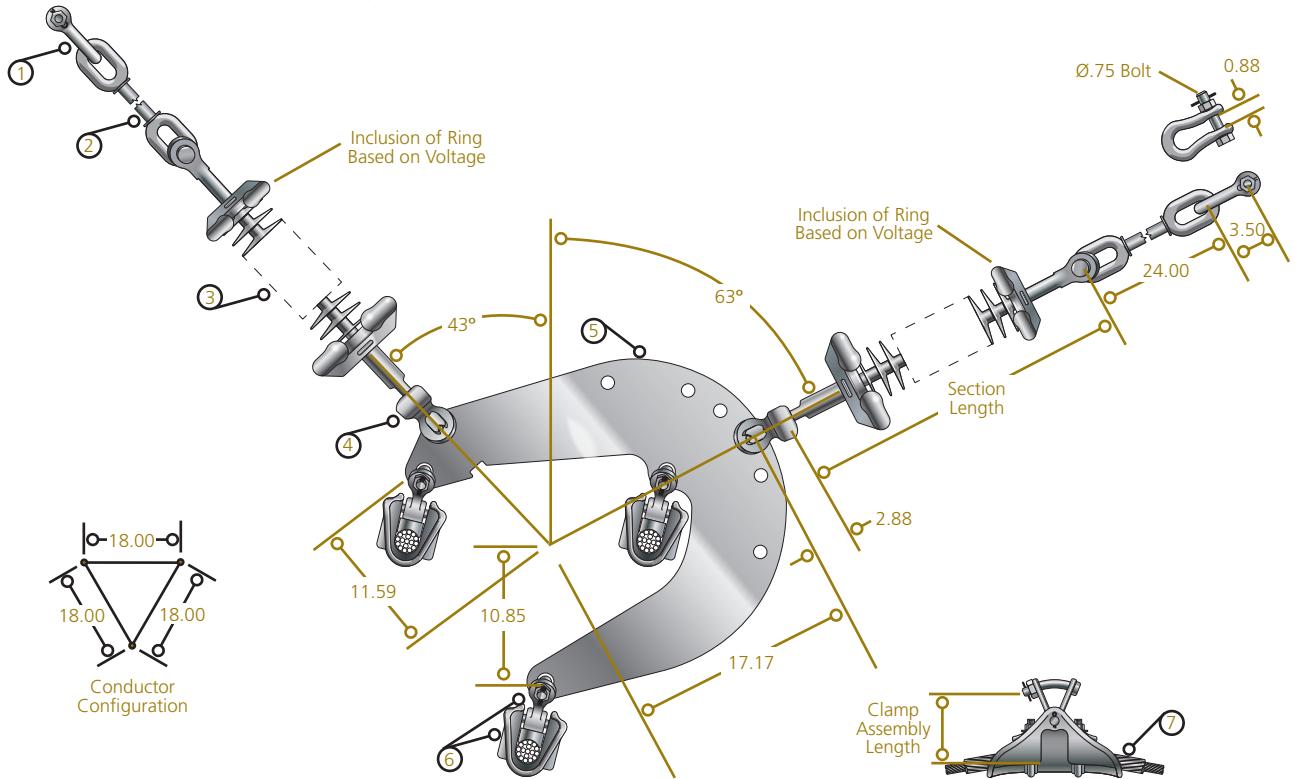

### Base Assembly Catalog Number: TEA-VX-32-50

Item	Part Number	Description	Quantity	Material	UBS lb
1	AS50BNK	Anchor Shackle	2	Forged Steel	60,000
2	H005024	Oval Eye Ext. Link (24")	2	Forged Steel	60,000
3	See Chart	Insulator, ANSI 52-11	2	Polymer	—
4	SYC50SN	Socket Y-Clevis	2	Ductile Iron	50,000
5	YPC5010833	Yoke Plate	1	Galvanized Steel	50,000
6	See Note 1	Suspension Clamp w/Y-Clevis	3	Aluminum	—
7	See Note 2	Armor Rods	3	Aluminum	—

### Typical Insulator Selection — See Note 3

Line Voltage (kV)	Quadri*Sil® Part Number	Section Length Inches	SML lb	Corona Ring
345	S050103S201B	117.8	50,000	12" Line End
300	S050155S201D	169.6	50,000	15" Line End 8" Ground End

**NOTE:** For quoting/ordering instructions, see Assemblies section.

- (1) See Suspension Clamp section for standard and high temperature conductor suspension clamp options.
- (2) Contact HPS for armor rod recommendations.
- (3) See Suspension Insulator section for additional insulator options.

# EHV Angle Suspension, 3-Bundle Conductor

## Double V-String 50k lb Assembly, TEA-DX-34-50, 345kV - 500kV

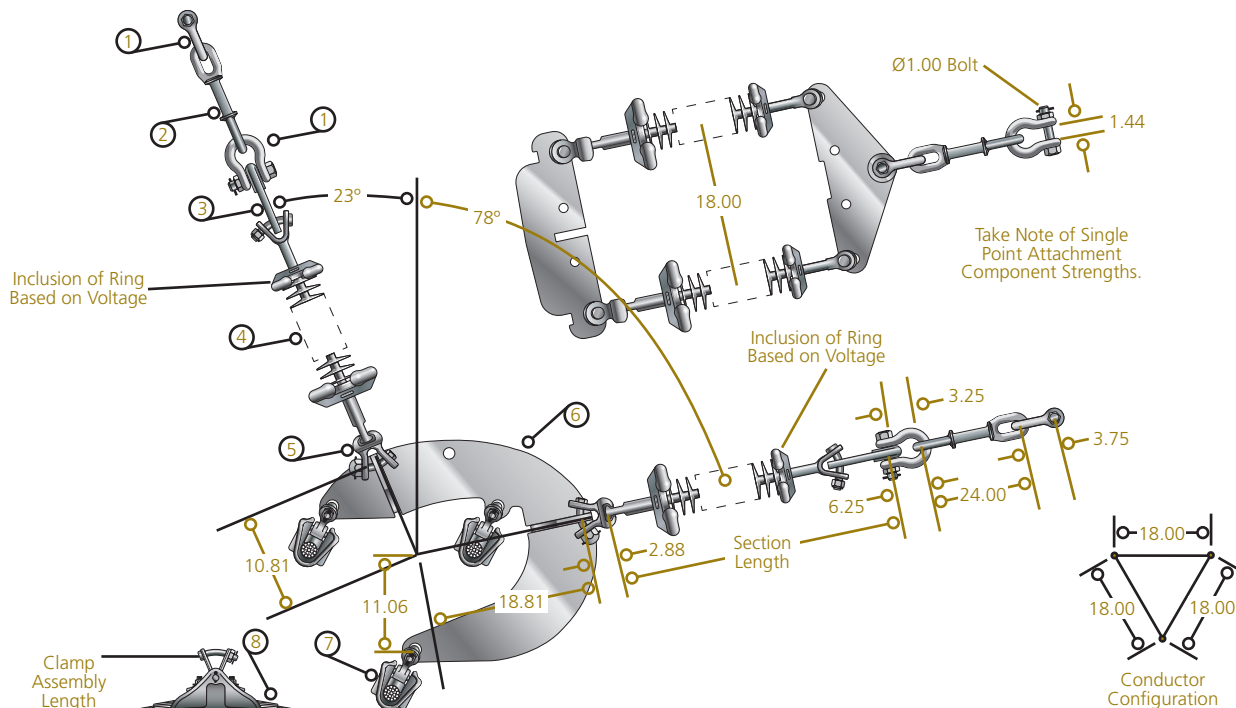

### Base Assembly Catalog Number: TEA-DX-34-50

Item	Part Number	Description	Quantity	Material	UBS lb
1	AS60BNK	Anchor Shackle	4	Forged Steel	80,000
2	HOOT8024	Oval Eye Ext. Link (24")	2	Forged Steel	80,000
3	YPD8018475	Yoke Plate	2	Ductile Iron	80,000
4	See Chart	Insulator, ANSI 52-11	4	Polymer	—
5	SYC50SN	Socket Y-Clevis	4	Ductile Iron	50,000
6	YPCB4011742	Yoke Plate	1	Galvanized Steel	40,000
7	See Note 1	Suspension Clamp w/Y-Clevis Eye	3	Aluminum	—
8	See Note 2	Armor Rods	3	Aluminum	—

### Typical Insulator Selection — See Note 3

Line Voltage (kV)	Quadri*Sil® Part Number	Section Length Inches	SML lb	Corona Ring
345	S050103S201B	117.8	50,000	12" Line End
500	S050155S201D	169.6	50,000	15" Line End 8" Ground End

**NOTE:** For quoting/ordering instructions, see Assemblies section.

- (1) See Suspension Clamp section for standard and high temperature conductor suspension clamp options.
- (2) Contact HPS for armor rod recommendations.
- (3) See Suspension Insulator section for additional insulator options.

# EHV Deadend, 2-Bundle Conductor

## Single Insulator 50k lb Assembly, TED-1X-21-50, 230kV - 345kV

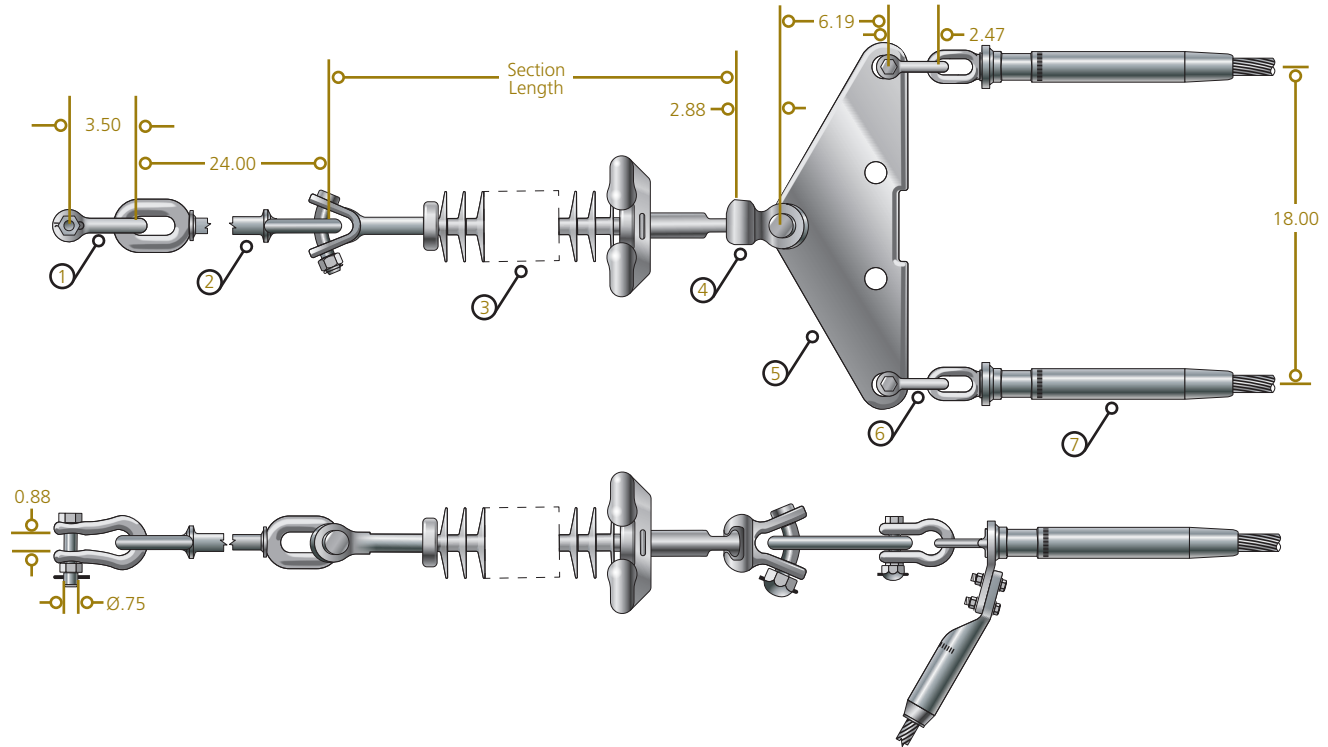

### Base Assembly Catalog Number: TED-1X-21-50

Item	Part Number	Description	Quantity	Material	UBS lb
1	AS50BNK	Anchor Shackle	1	Forged Steel	60,000
2	HOOT5024	Oval Eye Ext. Link (24")	1	Forged Steel	60,000
3	See Chart	Insulator, ANSI 52-11	1	Polymer	—
4	SYC50SN	4 Socket Y-Clevis	1	Ductile Iron	50,000
5	YPD50185491	Yoke Plate	1	Ductile Iron	50,000
6	AS25LBKSN	Anchor Shackle	2	Forged Steel	30,000
7	See Note 1	Compression Deadend w/Terminal	2	Aluminum	Full Tension

### Typical Insulator Selection — See Note 2

Line Voltage (kV)	Quadri*Sil® Part Number	Section Length Inches	SML lb	Corona Ring
230	S050073S201A	87.6	50,000	8" Line End
345	S050103S201B	117.8	50,000	12" Line End

**NOTE:** For quoting/ordering instructions, see Assemblies section.

- (1) See Compression Deadends section for standard conductor compression deadend options, See Compression Conventional (Two Die) System section for high temperature conductor compression deadend options.
- (2) See Suspension Insulator section for additional insulator options.

# EHV Deadend, 2-Bundle Conductor

## Double Insulator 30k lb Assembly, TED-1X-22-30, 230kV - 345kV

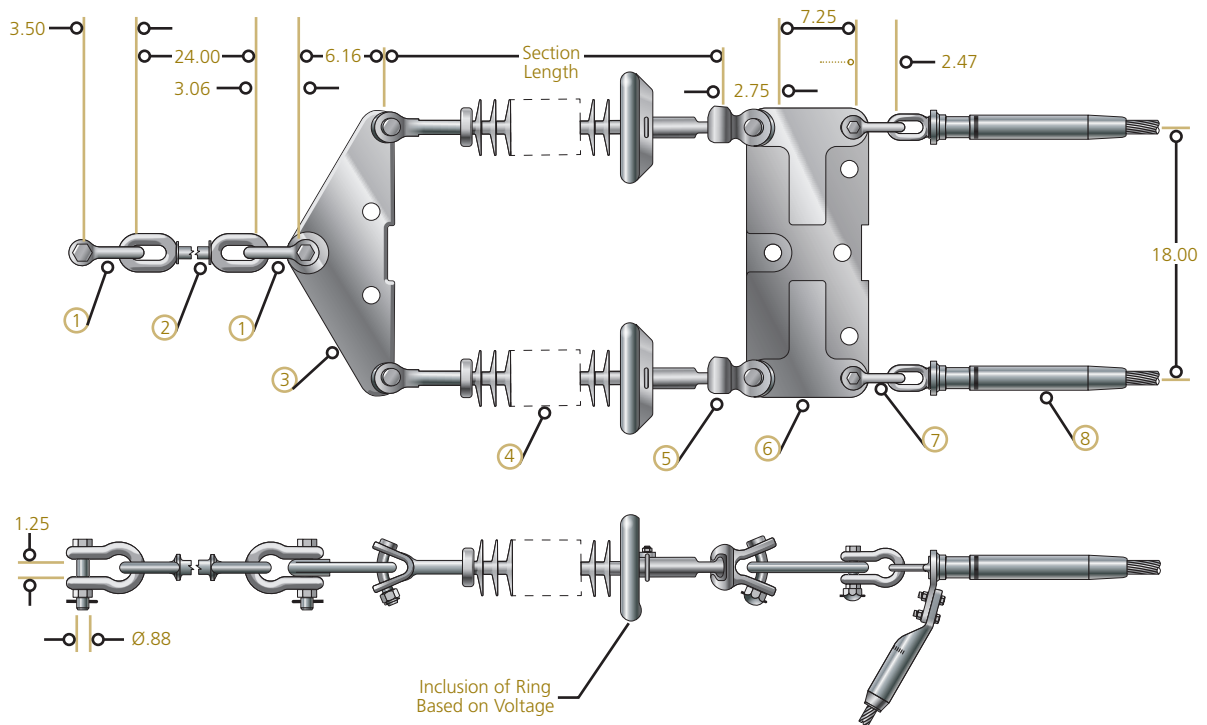

### Base Assembly Catalog Number: TED-1X-22-30

Item	Part Number	Description	Quantity	Material	UBS lb
1	AS50WBNK	Anchor Shackle	2	Forged Steel	60,000
2	H005024	Oval Eye Ext. Link (24")	1	Forged Steel	60,000
3	YPD60183771	Yoke Plate	1	Ductile Iron	60,000
4	See Chart	Insulator, ANSI 52-5	2	Polymer	—
5	SYC30SN	Socket Y-Clevis	2	Ductile Iron	30,000
6	YPR30187221	Yoke Plate	1	Ductile Iron	30,000
7	AS25LBNKSN	Anchor Shackle	2	Forged Steel	30,000
8	See Note 1	Compression Deadend w/Terminal	2	Aluminum	Full Tension

### Typical Insulator Selection — See Note 2

Line Voltage (kV)	Quadri*Sil® Part Number	Section Length Inches	SML lb	Corona Ring
230	S030073S201A	85.1	30,000	8" Line End
345	S030103S201B	115.3	30,000	12" Line End

**NOTE:** For quoting/ordering instructions, see Assemblies section.

- (1) See Compression Deadends section for standard conductor compression deadend options, See Compression Conventional (Two Die) System section for high temperature conductor compression deadend options.
- (2) See Suspension Insulator section for additional insulator options.

# EHV Deadend, 2-Bundle Conductor

## Double Insulator 50k lb Assembly, TED-1X-22-50, 230kV - 345kV

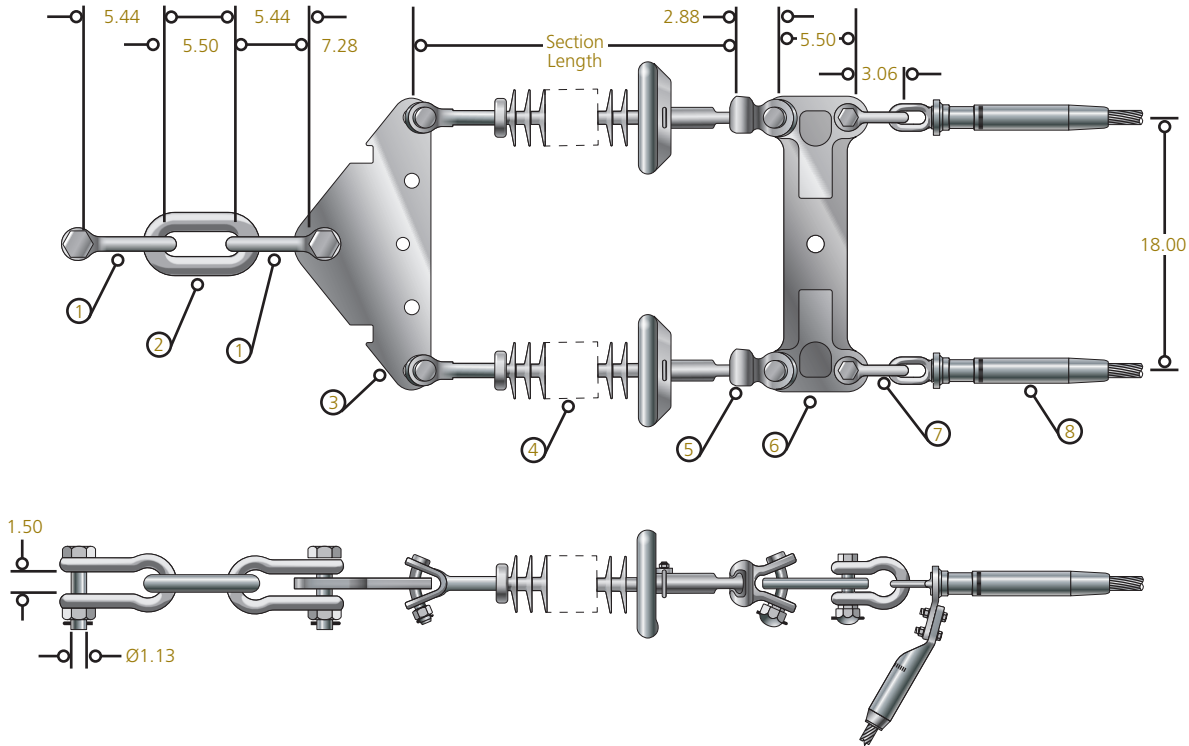

### Base Assembly Catalog Number: TED-1X-22-50

Item	Part Number	Description	Quantity	Material	UBS lb
1	974153001	Anchor Shackle	2	Forged Steel	120,000
2	LK150	Chain Link	1	Forged Steel	150,000
3	947604006	Yoke Plate	1	Galvanized Steel	100,000
4	See Chart	Insulator, ANSI 52-11	2	Polymer	—
5	SYC50SN	Socket Y-Clevis	2	Ductile Iron	50,000
6	YPR50190508	Yoke Plate	1	Ductile Iron	50,000
7	ASS0WBKNSN	Anchor Shackle	2	Forged Steel	60,000
8	See Note 1	Compression Deadend w/Terminal	2	Aluminum	Full Tension

### Typical Insulator Selection — See Note 2

Line Voltage (kV)	Quadri*Sil® Part Number	Section Length Inches	SML lb	Corona Ring
230	S050073S201A	87.6	50,000	8" Line End
345	S050103S201B	117.8	30,000	12" Line End

**NOTE:** For quoting/ordering instructions, see Assemblies section.

(1) See Compression Deadends section for standard conductor compression deadend options, See Compression Conventional (Two Die) System section for high temperature conductor compression deadend options.

(2) See Suspension Insulator section for additional insulator options.



# EHV Deadend, 3-Bundle Conductor

## Double Insulator 50k lb Assembly, TED-1X-32-50, 345kV - 500kV

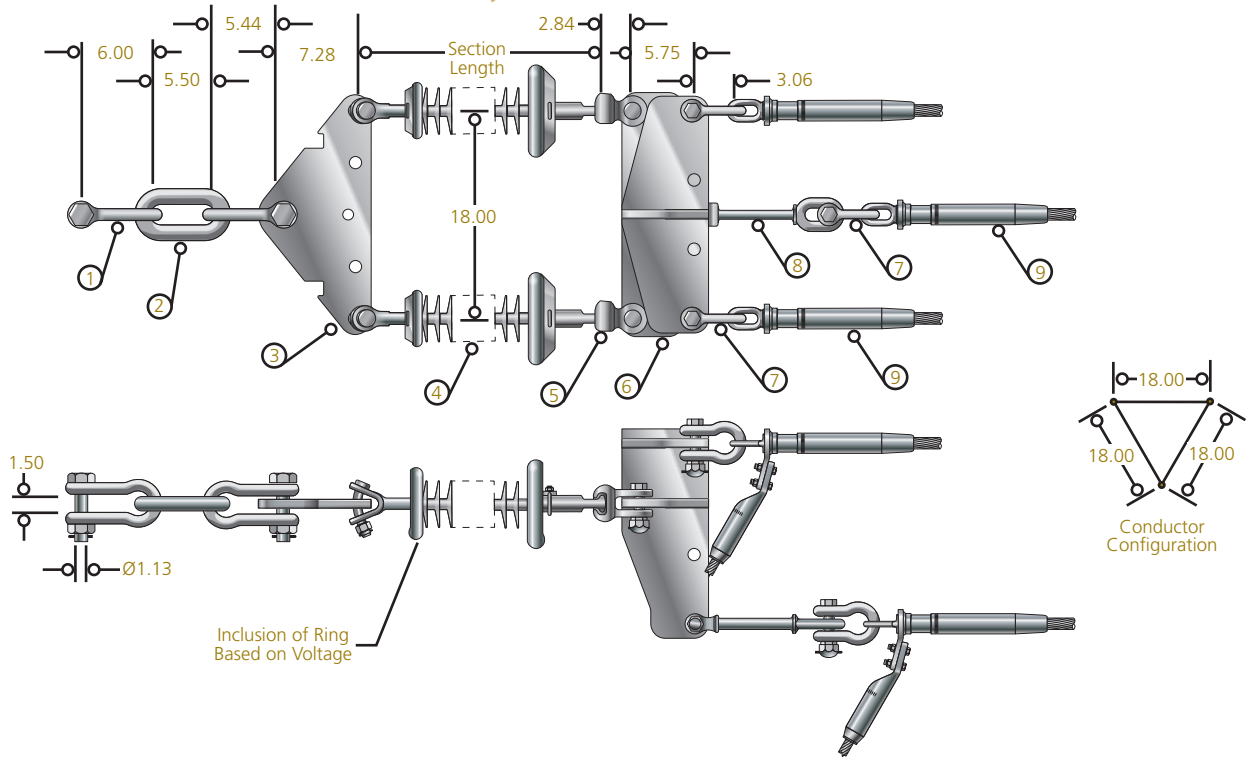

### Base Assembly Catalog Number: TED-1X-32-50

Item	Part Number	Description	Quantity	Material	UBS lb
1	974153001	Anchor Shackle	2	Forged Steel	120,000
2	LK150	Chain Link	1	Forged Steel	150,000
3	947604006	Yoke Plate	1	Galvanized Steel	100,000
4	See Chart	Insulator, ANSI 52-11	2	Polymer	50,000
5	SC501BNKSN	Socket Clevis	2	Ductile Iron	50,000
6	YPX5011275	Yoke Plate	1	Galvanized Steel	50,000
7	AS50WBKSN	Anchor Shackle	3	Forged Steel	60,000
8	FHOEC5012BNKSN	Chain Eye - Clevis Ext. Link (12")	1	Forged Steel	50,000
9	See Note 1	Compression Deadend w/Terminal	3	Aluminum	Full Tension

### Typical Insulator Selection — See Note 2

Line Voltage (kV)	Quadri*Sil® Part Number	Section Length Inches	SML lb	Corona Ring
345	S050103S201B	117.8	50,000	12" Line End
500	S050155S201D	169.6	50,000	15" Line End 8" Ground End

**NOTE:** For quoting/ordering instructions, see Assemblies section.

- (1) See Compression Deadends section for standard conductor compression deadend options, See Compression Conventional (Two Die) System section for high temperature conductor compression deadend options.
- (2) See Suspension Insulator section for additional insulator options.

# EHV Deadend, 3-Bundle Conductor

## Double Insulator 80k lb Assembly, TED-1X-32-80, 345kV - 500kV

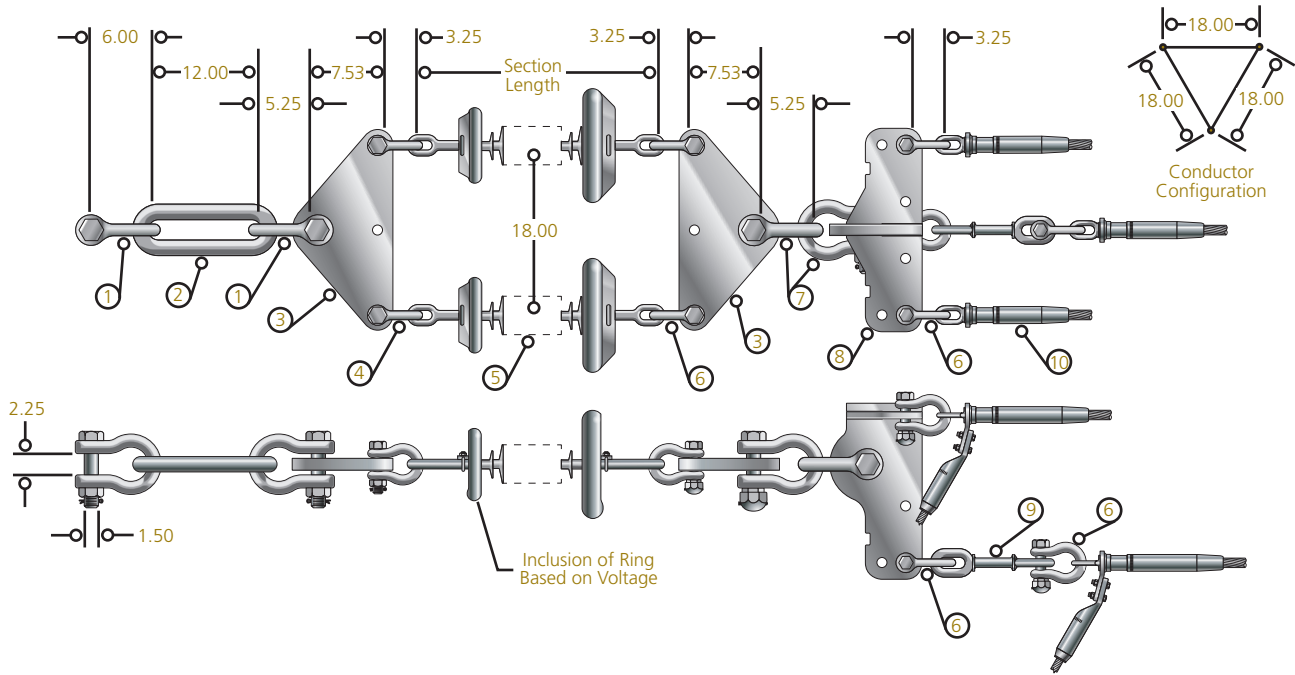

### Base Assembly Catalog Number: TED-1X-32-80

Item	Part Number	Description	Quantity	Material	UBS lb
1	M866AG	Anchor Shackle	2	Forged Steel	210,000
2	LK200	Chain Link	1	Forged Steel	200,000
3	YPD16011137	Yoke Plate	2	Galvanized Steel	160,000
4	AS60BNK	Anchor Shackle	2	Forged Steel	80,000
5	See Chart	Insulator, Eye-Eye	2	Polymer	80,000
6	AS60BNKSN	Anchor Shackle	6	Forged Steel	80,000
7	M866AGSN	Anchor Shackle	2	Forged Steel	210,000
8	YPX20012551	Yoke Plate	1	Galvanized Steel	200,000
9	HOOT5013	Chain Eye - Chain Eye Ext. Link (13")	1	Forged Steel	60,000
10	See Note 1	Compression Deadend w/Terminal	3	Aluminum	Full Tension

### Typical Insulator Selection — See Note 2

Line Voltage (kV)	Quadri*Sil® Part Number	Section Length Inches	SML lb	Corona Ring
345	S080103H000B	124.5	80,000	12" Line End
500	S080155H000D	176.3	80,000	15" Line End 8" Ground End

**NOTE:** For quoting/ordering instructions, see Assemblies section.

- (1) See Compression Deadends section for standard conductor compression deadend options, See Compression Conventional (Two Die) System section for high temperature conductor compression deadend options.
- (2) See Suspension Insulator section for additional insulator options.

# EHV Deadend, 3-Bundle Conductor

## Triple Insulator 50k lb Assembly, TED-1X-33-50, 345kV - 500kV

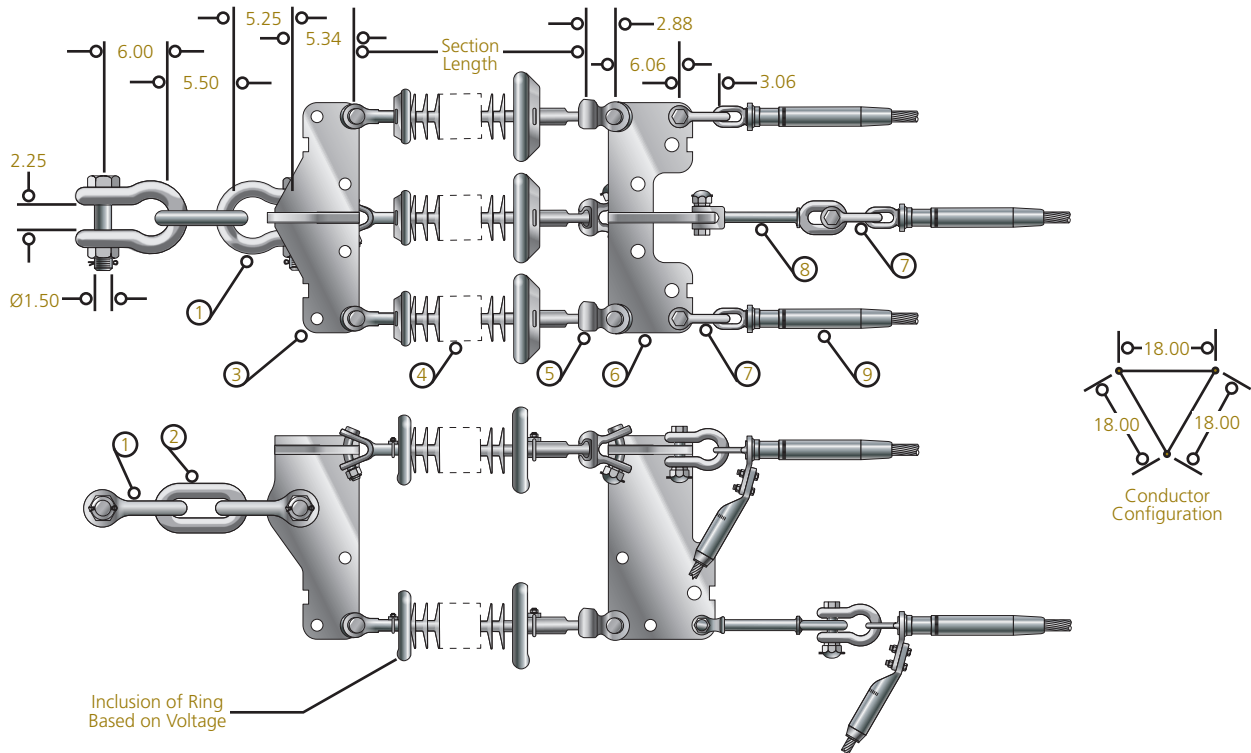

### Base Assembly Catalog Number: TED-1X-33-50

Item	Part Number	Description	Quantity	Material	UBS lb
1	AS135BNK	Anchor Shackle	2	Forged Steel	150,000
2	LK150	Chain Link	1	Forged Steel	150,000
3	YPX1509397	Yoke Plate	1	Galvanized Steel	150,000
4	See Chart	Insulator, ANSI 52-11	3	Polymer	50,000
5	SYC50SN	Socket Y-Clevis	3	Ductile Iron	50,000
6	YPX5011744	Yoke Plate	1	Galvanized Steel	50,000
7	AS50WBKSN	Anchor Shackle	3	Forged Steel	60,000
8	FHOEC5012BKSN	Chain Eye - Clevis Ext. Link (12")	1	Forged Steel	50,000
9	See Note 1	Compression Deadend w/Terminal	3	Aluminum	Full Tension

### Typical Insulator Selection — See Note 2

Line Voltage (kV)	Quadri*Sil® Part Number	Section Length Inches	SML lb	Corona Ring
345	S050103S201B	117.8	50,000	12" Line End
500	S050155S201D	169.6	50,000	15" Line End 8" Ground End

**NOTE:** For quoting/ordering instructions, see Assemblies section.

- (1) See Compression Deadends section for standard conductor compression deadend options, See Compression Conventional (Two Die) System section for high temperature conductor compression deadend options.
- (2) See Suspension Insulator section for additional insulator options.

# EHV Jumper Support, 2-Bundle Conductor

## 2.5" Post (Vertical) Insulator Assembly, TEJ-PH-21-25, 230kV - 345kV

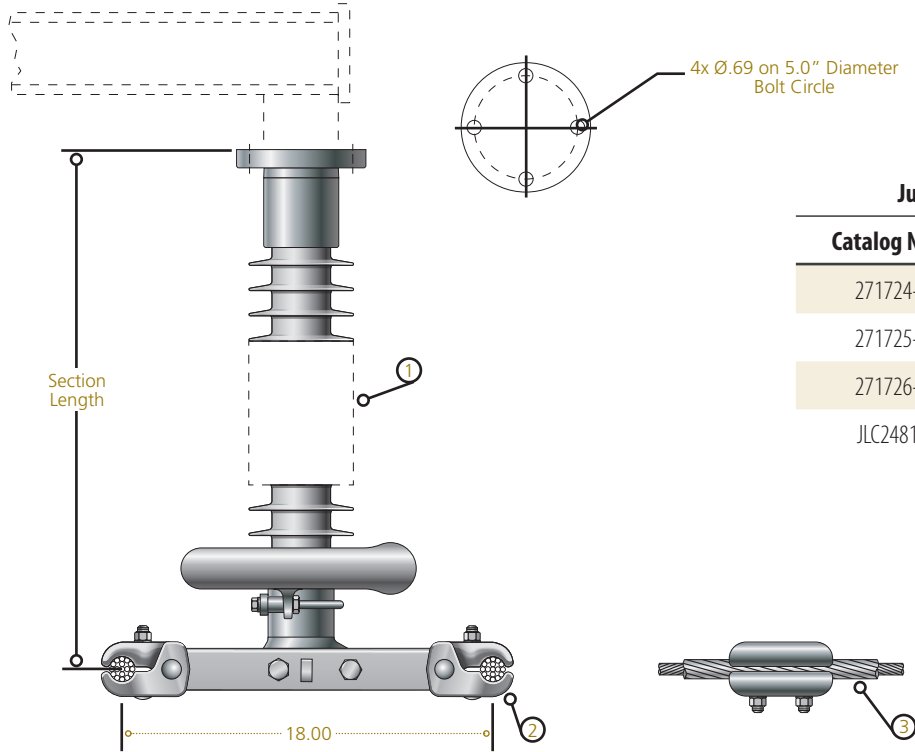

**Jumper Clamp Assembly**

Catalog Number	Clamp Range
271724-3001	1.00-1.40 Diameter
271725-3001	1.40-1.60 Diameter
271726-3001	1.60-2.00 Diameter
JLC24818275	2.00-2.48 Diameter

### Base Assembly Catalog Number: TEJ-PH-21-25

Item	Part Number	Description	Quantity	Material	UBS lb
1	See Chart	Insulator, Post w/Ring	1	Polymer	—
2	See Chart	Clamp Assembly	1	Steel/Aluminum	5,000
3	See Note 1	Armor Rods	2	Aluminum	—

### Typical Insulator Selection — See Note 2

Line Voltage (kV)	Quadri*Sil® Part Number	Section Length Inches	SCL lb	Corona Ring
230	P250070S530A	79.8	1,050	12" Line End
345	P250101S530A	111.3	740	12" Line End

**NOTE:** RCL is 50% of the ultimate cantilever load capacity.  
 Maximum design tension load rating is 7,500 lb.  
 For quoting/ordering instructions, see Assemblies section.

- (1) Contact HPS for armor rod recommendations.
- (2) See Line Post Insulators section for additional insulator options.

# EHV Jumper Support, 2-Bundle Conductor

## 2.5" Post (Horizontal) Insulator Assembly, TEJ-PX-21-25, 230kV - 345kV

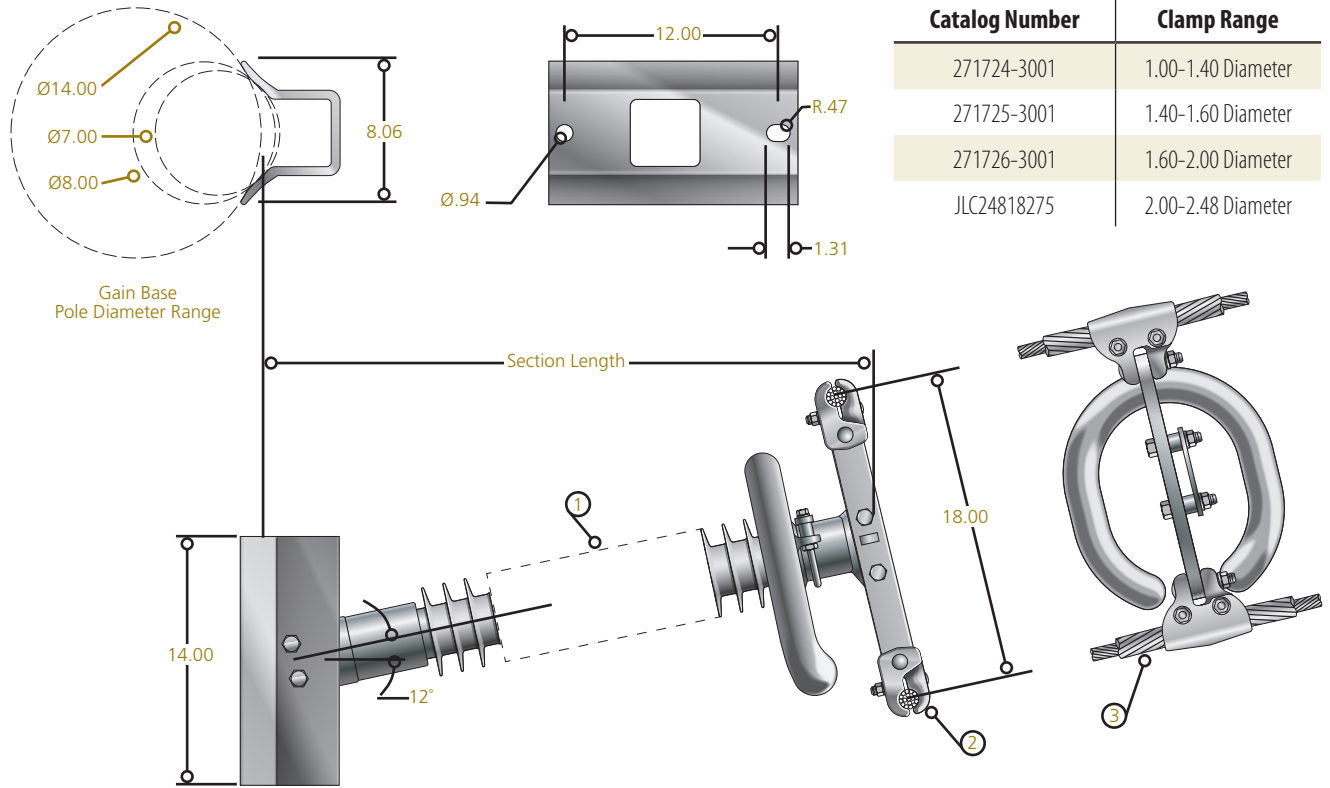

Jumper Clamp Assembly	
Catalog Number	Clamp Range
271724-3001	1.00-1.40 Diameter
271725-3001	1.40-1.60 Diameter
271726-3001	1.60-2.00 Diameter
JLC24818275	2.00-2.48 Diameter

### Base Assembly Catalog Number: TEJ-PX-21-25

Item	Part Number	Description	Quantity	Material	UBS lb
1	See Chart	Insulator, Post w/Ring	1	Polymer	—
2	See Chart	Clamp Assembly	1	Steel/Aluminum	5,000
3	See Note 1	Armor Rods	2	Aluminum	—

### Typical Insulator Selection — See Note 2

Line Voltage (kV)	Quadri*Sil® Part Number	Section Length Inches	RCL lb	Corona Ring
230	P250070S002A	81.9	1,050	12" Line End
345	P250101S002A	112.7	740	12" Line End

**NOTE:** RCL is 50% of the ultimate cantilever load capacity.  
 Maximum design tension load rating is 7,500 lb.  
 For quoting/ordering instructions, see Assemblies section.

- (1) Contact HPS for armor rod recommendations.
- (2) See Line Post Insulators section for additional insulator options.

# EHV Jumper Support, 2-Bundle Conductor

## 3" Post (Horizontal) Insulator Assembly, TEJ-PX-21-30, 230kV - 345kV

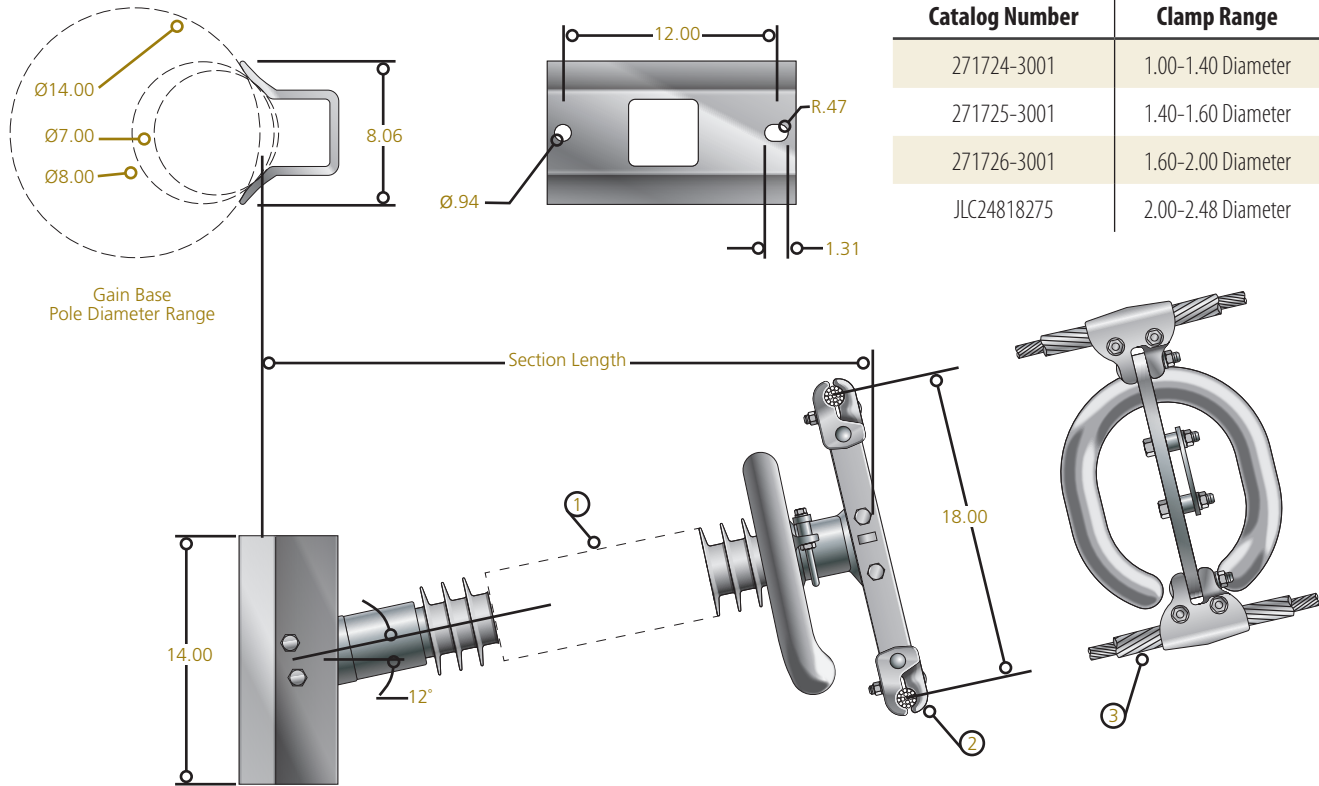

### Base Assembly Catalog Number: TEJ-PX-21-30

Item	Part Number	Description	Quantity	Material	UBS lb
1	See Chart	Insulator, Post w/Ring	1	Polymer	—
2	See Chart	Jumper Clamp Assembly	1	Steel/Aluminum	5,000
3	See Note 1	Armor Rods	2	Aluminum	—

### Typical Insulator Selection — See Note 2

Line Voltage (kV)	Quadri*Sil® Part Number	Section Length Inches	RCL lb	Corona Ring
230	P300074S002A	85.6	1,740	15" Line End
345	P300099S002A	110.4	1,315	15" Line End

**NOTE:** RCL is 50% of the ultimate cantilever load capacity.  
 Maximum design tension load rating is 12,500 lb.  
 For quoting/ordering instructions, see Assemblies section.  
 (1) Contact HPS for armor rod recommendations.  
 (2) See Line Post Insulators section for additional insulator options.



# EHV Jumper Support, 3-Bundle Conductor

## 3" Post (Vertical) Insulator Assembly, TEJ-PX-31-30, 345kV - 500kV

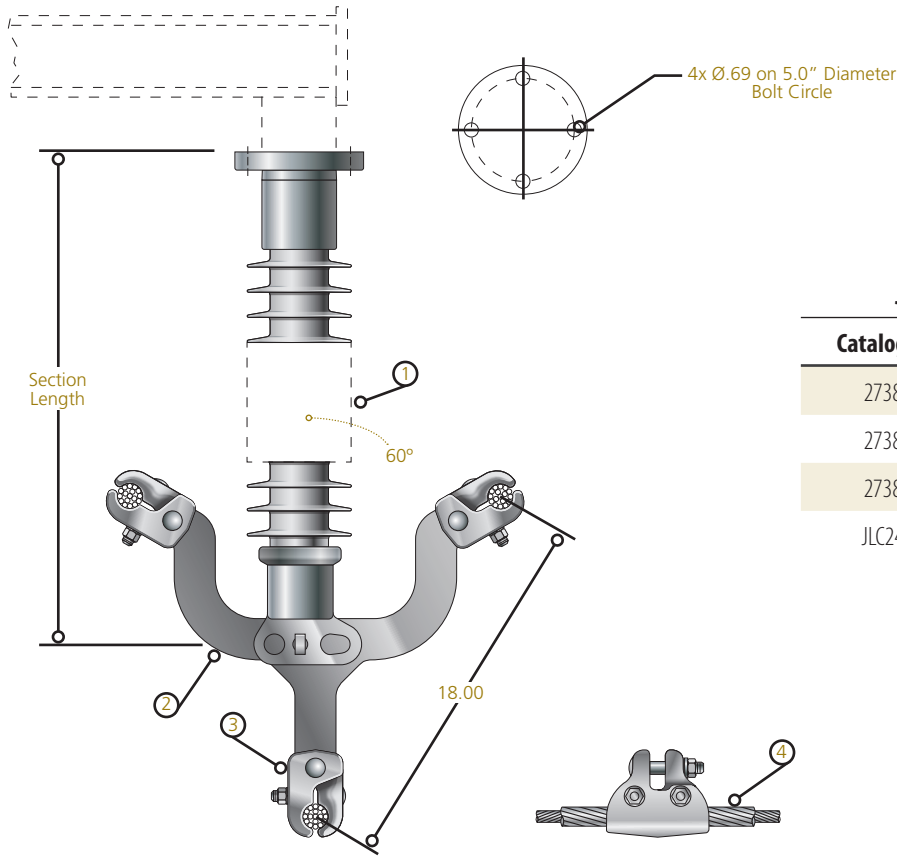

### Jumper Clamp Assemblies

Catalog Number	Clamp Range
2738413001	1.00-1.40 Diameter
2738423001	1.40-1.60 Diameter
2738433001	1.60-2.00 Diameter
JLC24818275	2.00-2.48 Diameter

### Base Assembly Catalog Number: TEJ-PX-31-30

Item	Part Number	Description	Quantity	Material	UBS lb
1	See Chart	Insulator, Post	1	Polymer	—
2	2717034001	Yoke Plate	1	Steel	5,000
3	See Chart	Jumper Loop Clamp	3	Aluminum	5,000
4	See Note 1	Armor Rods	3	Aluminum	—

### Typical Insulator Selection — See Note 2

Line Voltage (kV)	Quadri*Sil® Part Number	Section Length Inches	RCL lb	Corona Ring
345	P300099SSAAA	110.6	1,315	—
500	P300117SSAAA	128.8	1,120	—

- NOTE:** RCL is 50% of the ultimate cantilever load capacity.  
 Maximum design tension load rating is 12,500 lb.  
 For quoting/ordering instructions, see Assemblies section.
- (1) Contact HPS for armor rod recommendations.
  - (2) See Line Post Insulators section for additional insulator options.

# EHV Jumper Support, 2-Bundle Conductor

## Single Insulator with Weights 30k lb Assembly, TEJ-SH-21-30, 230kV - 345kV

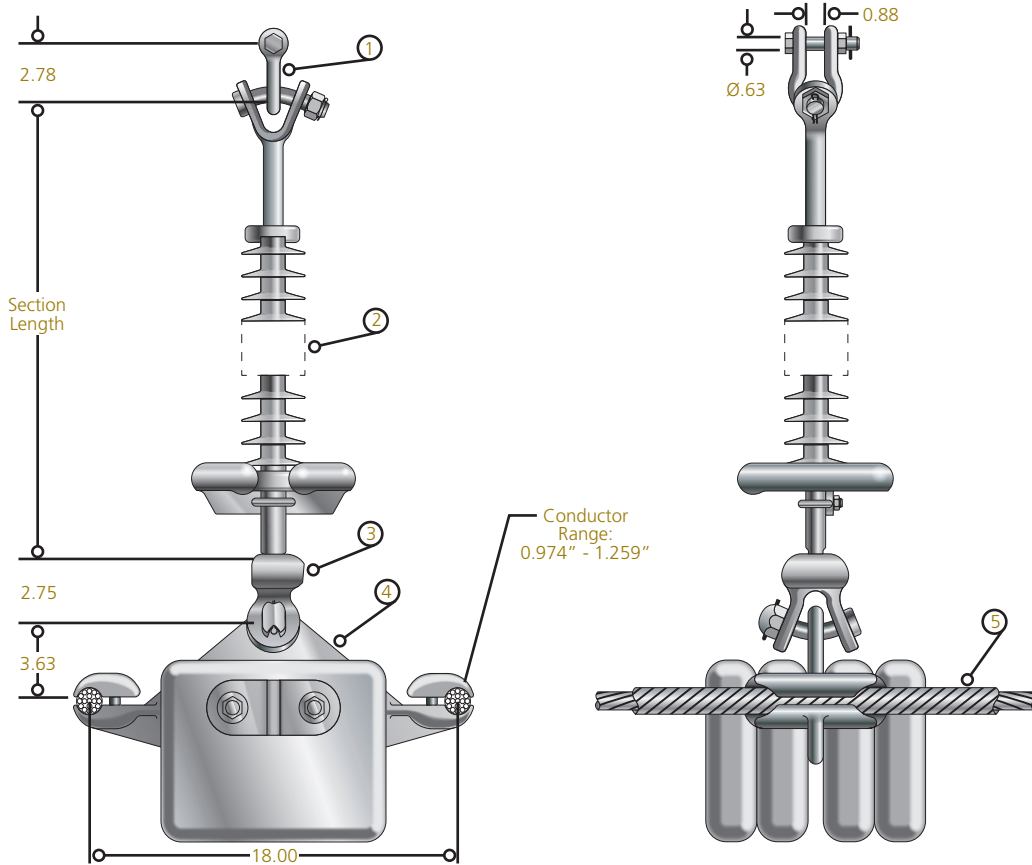

**Base Assembly Catalog Number: TEJ-SH-21-30**

Item	Part Number	Description	Quantity	Material	UBS lb
1	AS25LBNK	Anchor Shackle	1	Forged Steel	30,000
2	See Chart	Insulator, ANSI 52-5	1	Polymer	—
3	SYC30SN	Socket Y-Clevis	1	Ductile Iron	30,000
4	YPJ21018215200 <sup>(1)</sup>	Jumper Yoke w/Weights	1	Aluminum	10,000
5	See Note 2	Armor Rods	1	Aluminum	—

### Typical Insulator Selection — See Note 3

Line Voltage (kV)	Quadri*Sil® Part Number	Section Length Inches	SML lb	Corona Ring
230	S030073S201A	85.1	30,000	8" Line End
345	S030103S201B	115.3	30,000	12" Line End

**NOTE:** For quoting/ordering instructions, see Assemblies section.

- (1) For jumper yokes with other conductor ranges or different amounts of weight, please contact HPS.
- (2) Contact HPS for armor rod recommendations.
- (3) See Suspension Insulator section for additional insulator options.

# EHV Jumper Support, 3-Bundle Conductor

## Single Insulator with Weights 30k lb Assembly, TEJ-SH-31-30, 345kV - 500kV

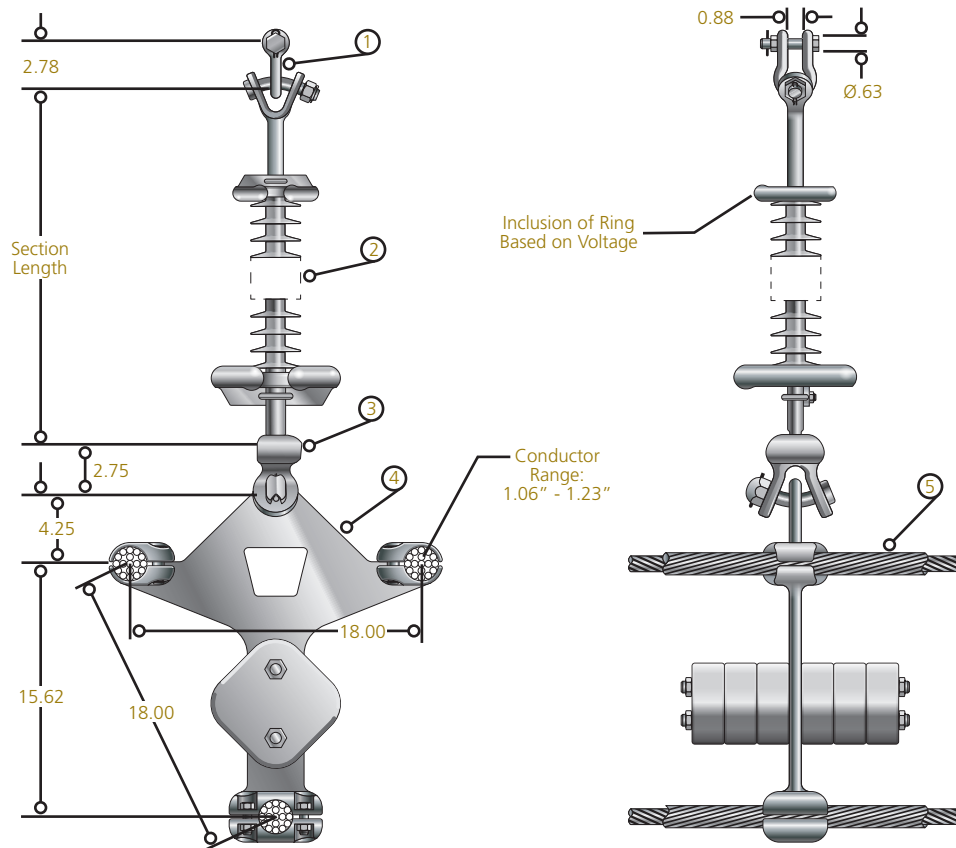

### Base Assembly Catalog Number: TEJ-SH-31-30

Item	Part Number	Description	Quantity	Material	UBS lb
1	AS25LBK	Anchor Shackle	1	Forged Steel	30,000
2	See Chart	Insulator, ANSI 52-5	1	Polymer	—
3	SYC30SN	Socket Y-Clevis	1	Ductile Iron	30,000
4	YPJ310251891300 <sup>(1)</sup>	Jumper Yoke Assembly	1	Aluminum	10,000
5	See Note 2	Armor Rods	1	Aluminum	—

### Typical Insulator Selection — See Note 3

Line Voltage (kV)	Quadri*Sil® Part Number	Section Length Inches	SML lb	Corona Ring
345	S030103S201B	115.3	30,000	12" Line End
500	S030155S201D	167.2	30,000	15" Line End 8" Ground End

**NOTE:** for quoting/ordering instructions, see Assemblies section.

- (1) For jumper yokes with other conductor ranges or different amounts of weight, please contact HPS.
- (2) Contact HPS for armor rod recommendations.
- (3) See Suspension Insulator section for additional insulator options.



Hubbell Power Systems  
210 N. Allen  
Centralia, MO 65240 USA

CA00067E

©Copyright 2013 Hubbell Incorporated

**HUBBELL**<sup>®</sup>  
Power Systems

*NEVER COMPROMISE*<sup>™</sup>  
[hubbellpowersystems.com](http://hubbellpowersystems.com)

