

Multiple Outlet Connectors

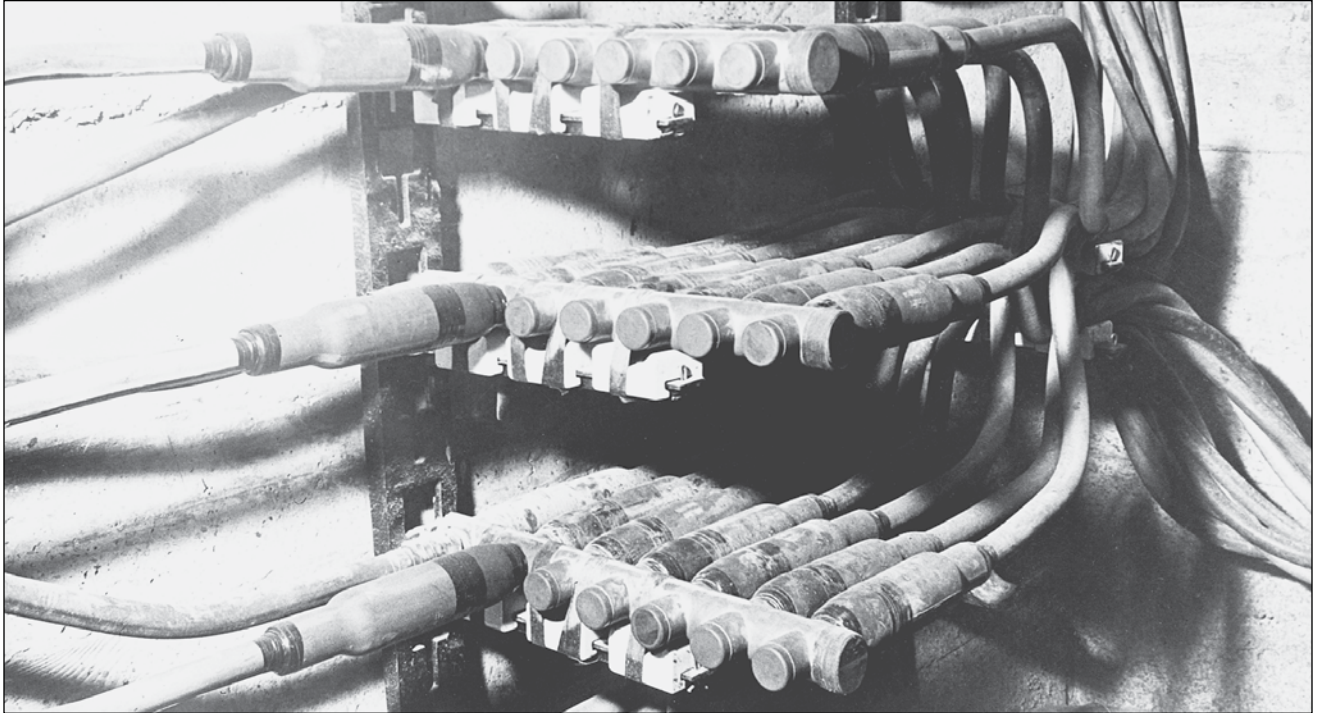

Connectors for Aluminum

For systems where aluminum is used, connectors especially designed for aluminum conductors are available in bolted and compression types: HYCRAB™, HYPLUG™, HYREDUCER™, and HYSOCKET. Aluminum conductors can be connected to standard MOLE™ connectors by using HYPLUG™ YE-R type adapters in catalog section H. Contact customer service for specific recommendations to connect aluminum conductor to MOLE™ and HYCRAB™ multiple outlet connectors.

Multiple Outlet Connectors

The increasing use in modern electrical distribution systems of junction points where several relatively large cables must be connected, has brought about the development of BURNDY® MOLE™ line equipment to speed up and simplify the making of such connections. The modern tendency toward network systems not only in underground utility practice but also in industrial wiring, has greatly increased the number of multi-connection joints.

The BURNDY® MOLE™ and HYCRAB™ connectors are insulated bus bars with multiple connector outlets for service cables, secondary mains or equipment leads. In the MOLE™, clamping action secures conductors to the connector; in the HYCRAB™, connections are made by indenting with a compression tool. Both lines of insulated connectors offer the following basic advantages:

1. **Ease of Economy and Installations:** The ease and reduction of time required to make and insulate dependable multi-connections greatly reduces the cost of installation. The compact design makes maximum use of space and provides for simplified racking.

2. **Versatility for System Modification:** The MOLE™ and HYCRAB™ are designed to accommodate the secondary main and service cables, and permit easy modification or later additions. The numerous available connector configurations permit a wide variety of arrangements of cables and equipment connections. The 600 volt rating of the MOLE™ and HYCRAB™ insulation provides for efficient operation at all standard utilization voltages.
3. **Efficient, Dependable Performance:** The MOLE™ and HYCRAB™ connectors assure permanent, high conductivity connections, good moisture seal, and insulation that resists the severest condition encountered in underground installations.

MOLE™ and HYCRAB™ Insulation

The location in vaults and manholes often exposes these connectors to immersion in water, chemical, and other contaminants, as well as to heat from overload or fault currents. The MOLE™ and HYCRAB™ insulations provide electrical, mechanical, and thermal properties essential to assure the service continuity of underground distribution systems.

Recognizing the importance of proper connection insulation, BURNDY established performance specifications exceeding those of 600 volt cable insulation.

Multiple Outlet Connectors (Continued)

The MOLE™ and MOLE™ Accessories

The BURNDY® MOLE™ is a multi-cable connectors that consists of a pre-insulated copper bus bar with threaded outlets that permit a minimum of two cables to be connected by means of a socket, nut, and cone assembly (Illustration A). The clamping action of the socket, nut, and cone assembly on the cable develops high contact pressures that maintain joint conductivities greater than 100% of the continuous conductor.

The MOLE™ design affords exceptional versatility in four ways:

1. MOLE™ outlets can be plugged-off until needed for the addition of cables.
2. Installed cables can be easily removed.
3. Cable sizes can be increased by changing the socket, nut, and cone assembly.
4. The number of outlets may be increased by joining MOLE™ connectors with a MOLE™ coupler.

Insulation

The copper bus bar insert is encased in a molded insulating jacket that eliminates copper crotch taping. The thickness of the jacket prevents any possibility of the insert weight to cause the insulation at the supports to flow away at the high temperatures of fault conditions.

Ratings

MOLE™ connectors are rated at 1500, 2000, 2500, and 3000 amperes, based on the maximum current the insert cross-section can carry. Each outlet can carry the full rated current of the cable connected to it.

To avoid exceeding the insert rating, the cables should be arranged in such a manner that most current flows directly across the insert. (See Illustration B.)

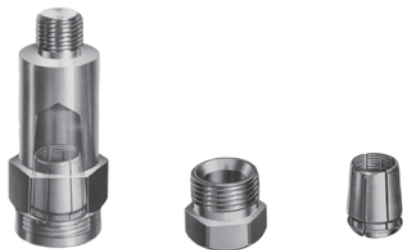

Illustration A

Installation

Cables are connected to the MOLE™ by means of a socket, nut and compression cone assembly. The socket is threaded into the MOLE™ insert. The stripped cable end is inserted into nut and compression cone, and then into the socket where it is securely clamped by tightening the nut. The joint is then sealed watertight in one of three ways:

- Taping;
- MOLE™ Outlet Insulating Sleeves, sealed with a minimum of taping;

Tests under flooding and other adverse conditions demonstrate that such joints are impervious to water.

Accessories

A socket, cone and nut assembly is screwed into each MOLE™ outlet to which a cable is to be connected. The socket has a tapered recess into which the clamping nut forces the cable into the compression cone. The cone is slotted to controlled widths and depths for maximum flexibility, and its inside surface is serrated for low contact resistance and high pullout strength.

Plug seal MOLE™ outlets not in use. The MOLE™ is delivered with one-fourth of its outlets sealed with plugs. Additional plugs may be ordered.

MOLE™ couplers facilitate system expansion by joining additional MOLE™ connectors to those already installed. Couplers are easily installed in end or side outlets of the MOLE™, and make connections that are effective both electrically and mechanically.

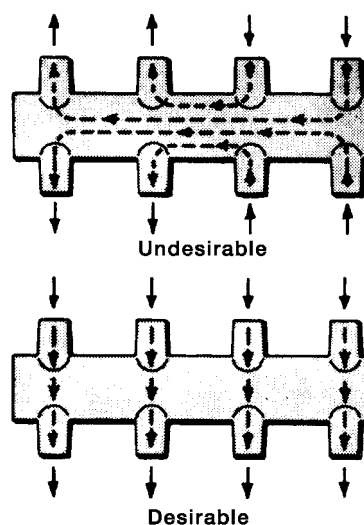
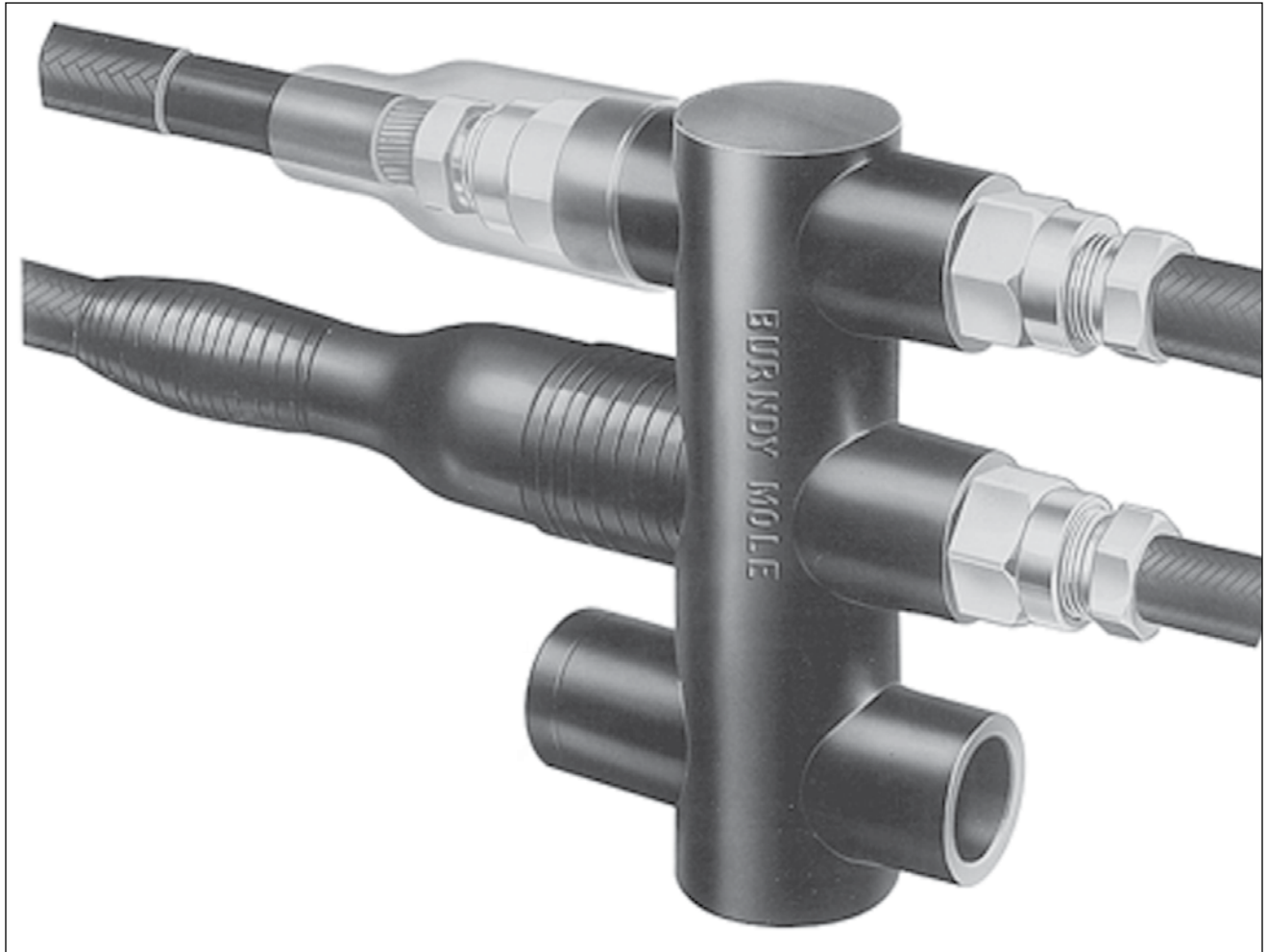

Illustration B

Multiple Outlet Connectors (Continued)



MOLE™ Connector Selection Considerations

Conductor Type:

- Copper Stranded - Adapts directly to MOLE™ using Z-NR type socket nut and Z MOLE™ compression cone
- Aluminum Stranded - Use type YE-R HYPLUG™ to adapt to Z-NR style socket nut and Z MOLE™ compression cone (contact customer service for recommendations)

Amperes:

- Ratings are for maximum current at any point along the cross section of the connector bus
- Each outlet is rated for the full current capability of the attached conductor or coupler
- This catalog shows 1500, 2500, and 3000A variations; contact customer service for other ampacity ratings

MOLE™ Bus Configuration:

- Selection based on desired conductor routing
- Determine if multiple MOLE™ connectors will be joined; End connection points (1) / (X) in ZMT, ZML, ZMX, and ZMK style configurations are often used for this purpose
- See descriptions in the ordering matrix and illustrations
- Contact customer service for ordering tables for configurations not included in this catalog

Number of Outlets:

- 2 to 18 outlets are available on a single MOLE™ depending on bus configuration
- Connect multiple MOLE™ bus together if a greater number of outlets is required

Connection Point Configuration:

- See "Connection Point Options" table to determine the size required

End connection point (1) / (X) size can be made different from those on the bus side(s) (2 - n) by changing the part number suffix.

Contact customer service for options to have different size connection points on the side(s) of the MOLE™ bus.

Bus Configuration Illustrations

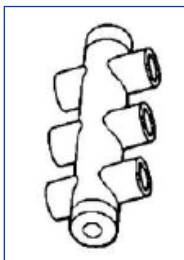

ZM

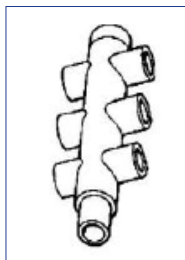

ZMT

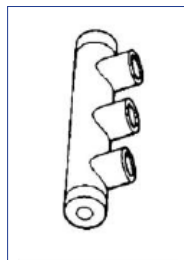

ZME

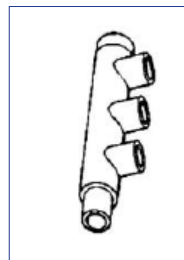

ZML

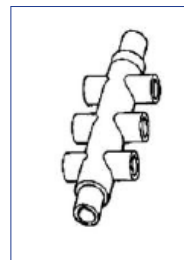

ZMX

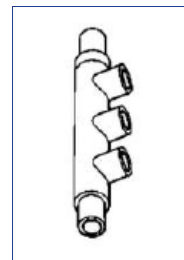

ZMK

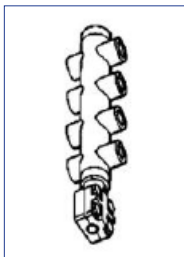

ZMTDN

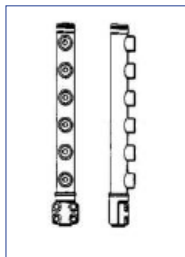

ZMLDN

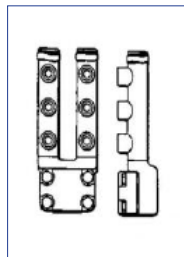

Z2MLDN

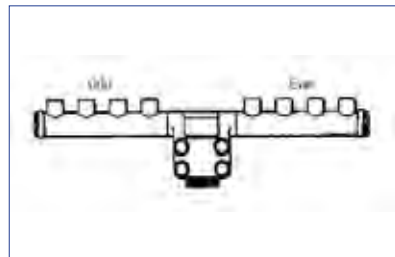

ZMDN

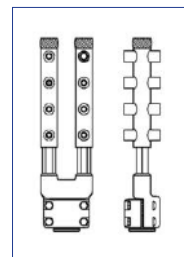

Z2MTDN

Ordering Matrix

Catalog Number Example: ZMT725A7			
ZMT	7	25	A7
Bus Configuration	Total Qty Connection Points	Amperage Rating	Connection Point Configuration

Bus Configuration (See Illustrations)	
Value	Description
ZM	Both Sides
ZMT	Both Sides + 1 End
ZMX	Both Sides + 2 Ends
ZME	One Side
ZML	One Side + 1 End
ZMK	One Side + 2 Ends
ZMDN	Horizontal Stud MOLE™
ZMLDN	One Side Vertical Stud MOLE™, 1 Tree
Z2MLDN	One Side Vertical Stud MOLE™, 2 Trees
ZMTDN	Both Sides Vertical Stud MOLE™, 1 Tree
Z2MTDN	Both Sides Vertical Stud MOLE™, 2 Trees

Ampere Rating	
Value	Amp Rating
15	1500
20	2000
25	2500
30	3000

Connection Point Configuration			
Value	Bus Config	Primary Size	End Size
None	All	A	A
B		B	B
C		C	C
A3	ZMT or ZML	A	B
A9		A	C
B12		B	A
B92	ZMX or ZMK	B	C
A4		A	B
A7		A	C
B72	B	C	C

Connection Point Options			
Socket Size	Compact Stranding	Concentric / Compressed	MOLE™ to MOLE™ Coupler
A	#2 - 600 kcmil	#6 - 600 kcmil	ZMS29 (1200A)
B	2/0 - 750 kcmil	250 - 1000 kcmil	ZMS34 (1600A)
C	Contact Customer Service	1250 - 2000 kcmil	ZMS40 (2000A)

OUTLET HOLE NUMBERING

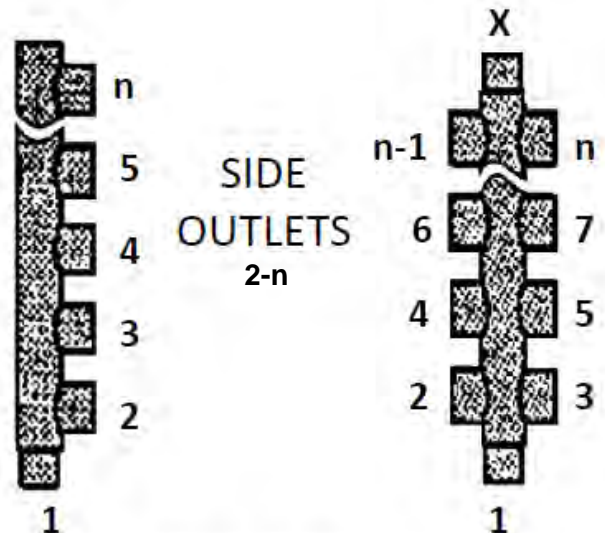

END OUTLETS
1 and X

MOLE™ Type ZM

MOLE™ Type ZM — A compact pre-insulated junction for secondary network cables, with multiple outlets for each cable clamping elements.

Outlet Plugs — MOLE™ outlet plugs that facilitate sealing outlets not being used are available. Type Z-P and Type K-P, sold separately.

Insulating Sleeves — Taping operations for watertight joints are greatly simplified by the use of BURNDY® Type CM or MOLE™ Insulating Sleeves Type Z-C, sold separately.

Clamping Elements — Outlet Symbols A or B, refer to socket and nut Type Z-NR, and Cone Type Z cable clamping elements accommodated. These must be ordered separately.

OUTLET RANGE: "A" 6 Str. - 600 kcmil
"B" 2 Str. - 1000 kcmil

Catalog Number	Ampere Capacity	Cable Outlet Arrangement	Qty of Outlets	Length "L" Inches
ZM415	1500	All Outlets A	4	7.1
ZM615			6	10.1
ZM815			8	13.1
ZM1015			10	16.1
ZM1215			12	19.1
ZM1415			14	22.1
ZM1615			16	25.1
ZM425	2500	All Outlets A	4	8.0
ZM625			6	11.5
ZM825			8	15.0
ZM1025			10	18.5
ZM1225			12	22.0
ZM1425			14	25.5
ZM1625			16	29.0
ZM430	3000	All Outlets A	4	6.9
ZM630			6	10.3
ZM830			8	13.7
ZM1030			10	17.1
ZM1230			12	20.4
ZM1430			14	23.8
ZM1630			16	27.2

MOLE™ DIMENSIONS

"W" Dimension: 4-1/8"
Center-to-Center distance between outlets: 3"

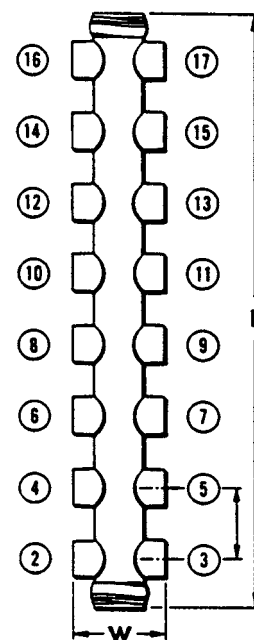

Catalog Number	Ampere Capacity	Cable Outlet Arrangement	Qty of Outlets	Length "L" Inches
ZM425B	2500	All Outlets B	4	8.0
ZM625B			6	11.5
ZM825B			8	15.0
ZM1025B			10	18.5
ZM1225B			12	22.0
ZM1425B			14	25.5
ZM1625B			16	29.0
ZM430B	3000	All Outlets B	4	6.9
ZM630B			6	10.3
ZM830B			8	13.7
ZM1030B			10	17.1
ZM1230B			12	20.4
ZM1430B			14	23.8
ZM1630B			16	27.2



Contact Customer Service for Additional Outlet Configurations

MOLE™ Type ZMT

MOLE™ Type ZMT — A compact pre-insulated junction for secondary network cables, with multiple outlets for cable clamping elements. Future expansion is provided for by an end outlet which can be joined to an additional MOLE™ by Type ZMS couplers.

Outlet Plugs — MOLE™ outlet plugs that facilitate sealing outlets not being used are available. Type Z-P and Type K-P, sold separately.

Insulating Sleeves — Taping operations for watertight joints are greatly simplified by the use of BURNDY® Type CM or MOLE™ Insulating Sleeves Type Z-C, sold separately.

Clamping Elements — Outlet Symbols A or B, refer to socket and nut Type Z-NR, and Cone Type Z cable clamping elements accommodated. These must be ordered separately.

OUTLET RANGE: "A" 6 Str. - 600 kcmil
"B" 2 Str. - 1000 kcmil

Catalog Number	Ampere Capacity	End ① *	Other	Qty of Outlets	Length "L" Inches
ZMT315	1500	A	A	3	5
ZMT515				5	8
ZMT715				7	11
ZMT915				9	14
ZMT1115				11	19
ZMT1315				13	20
ZMT1515				15	23
ZMT1715				17	26
ZMT325	2500	A	A	3	5.5
ZMT525				5	9
ZMT725				7	12.5
ZMT925				9	16
ZMT1125				11	19.5
ZMT1325				13	23
ZMT1525				15	26.5
ZMT1725				17	30
ZMT330	3000	A	A	3	5.5
ZMT530				5	9
ZMT730				7	12.5
ZMT930				9	16
ZMT1130				11	19.5
ZMT1330				13	23
ZMT1530				15	26.5
ZMT1730				17	30

MOLE™ DIMENSIONS

"W" Dimension: 4-1/2"
Center-to-Center distance between outlets: 3-1/2"

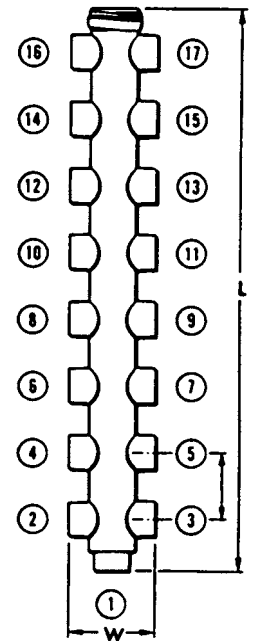

Catalog Number	Ampere Capacity	End ① *	Other	Qty of Outlets	Length "L" Inches
ZMT325B	2500	B	B	3	5.5
ZMT525B				5	9
ZMT725B				7	12.5
ZMT925B				9	16
ZMT1125B				11	19.5
ZMT1325B				13	23
ZMT1525B				15	26.5
ZMT1725B				17	30
ZMT330B	3000	B	B	3	5.5
ZMT530B				5	9
ZMT730B				7	12.5
ZMT930B				9	16
ZMT1130B				11	19.5
ZMT1330B				13	23
ZMT150B				15	26.5
ZMT1730B				17	30



*Add Suffix "A3" to Change End Outlet ① to Size B
*Add Suffix "A9" to Change End Outlet ① to Size C
Contact Customer Service for Additional Outlet Configurations.

MOLE™ Type ZMX

MOLE™ Type ZMX — A compact pre-insulated junction for secondary network cables, with multiple outlets for cable clamping elements. Future expansion is provided for by an end outlet which can be joined to an additional MOLE™ by Type ZMS couplers.

Outlet Plugs — MOLE™ outlet plugs that facilitate sealing outlets not being used are available. Type Z-P and Type K-P, sold separately.

Insulating Sleeves — Taping operations for watertight joints are greatly simplified by the use of BURNDY® Type CM or MOLE™ Insulating Sleeves Type Z-C, sold separately.

Clamping Elements — Outlet Symbols A or B, refer to socket and nut Type Z-NR, and Cone Type Z cable clamping elements accommodated. These must be ordered separately.

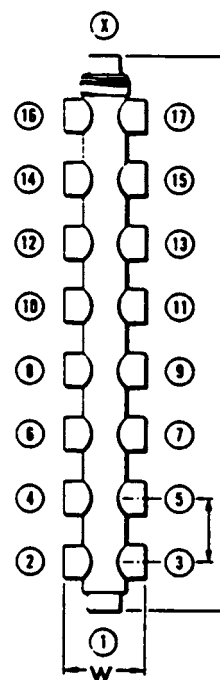

MOLE™ DIMENSIONS

“W” Dimension: 4-1/2”
Center-to-Center
distance between
outlets: 3-1/2”

OUTLET RANGE: “A” 6 Str. - 600 kcmil
“B” 2 Str. - 1000 kcmil

Catalog Number	Ampere Capacity	End ⓐ + (X)*	Other	Qty of Outlets	Length “L” Inches
ZMX415	1500	A	A	4	6
ZMX615				6	9
ZMX815				8	12
ZMX1015				10	15
ZMX1215				12	18
ZMX1415				14	21
ZMX1615				16	24
ZMX1815				18	27
ZMX425	2500	A	A	4	6.5
ZMX625				6	10
ZMX825				8	13.5
ZMX1025				10	17
ZMX1225				12	20.5
ZMX1425				14	24
ZMX1625				16	27.5
ZMX1825				18	31
ZMX430	3000	A	A	4	6.5
ZMX630				6	10.1
ZMX830				8	13.5
ZMX1030				10	16.9
ZMX1230				12	20.3
ZMX1430				14	23.6
ZMX1630				16	27
ZMX1830				18	30.4

Catalog Number	Ampere Capacity	End ⓐ + (X)*	Other	Qty of Outlets	Length “L” Inches
ZMX425B	2500	B	B	4	6.5
ZMX625B				6	10
ZMX825B				8	13.5
ZMX1025B				10	17
ZMX1225B				12	20.5
ZMX1425B				14	24
ZMX1625B				16	27.5
ZMX1825B				18	31
ZMX430B	3000	B	B	4	6.5
ZMX630B				6	10.1
ZMX830B				8	13.5
ZMX1030B				10	16.9
ZMX1230B				12	20.3
ZMX1430B				14	23.6
ZMX1630B	16	27			
ZMX1830B	18	30.4			



*Add Suffix “A4” to Change End Outlet ⓐ to Size B
*Add Suffix “A7” to Change End Outlet ⓐ to Size C
Contact Customer Service for Additional Outlet Configurations.

MOLE™ Stud Connector Type ZMLDN
For Connecting Copper Cables to Network Protector

To terminate one or more cables at the studs of distribution transformers, network protectors, or other apparatus. The body, except for the clamping element, is completed insulated. A separate clamping cap over the stud is provided that permits easy removal of the MOLE™ Stud Connector. This permits work to be done on the Network Protector without unduly disturbing the cables.

Outlet Plugs — MOLE™ outlet plugs that facilitate sealing outlets not being used are available. Type Z-P and Type K-P, sold separately.

Insulating Sleeves — Taping operations for watertight joints are greatly simplified by the use of BURNDY® Type CM or MOLE™ Insulating Sleeves Type Z-C, sold separately.

Clamping Elements — Outlet Symbols A or B, refer to socket and nut Type Z-NR, and Cone Type Z cable clamping elements accommodated. These must be ordered separately.

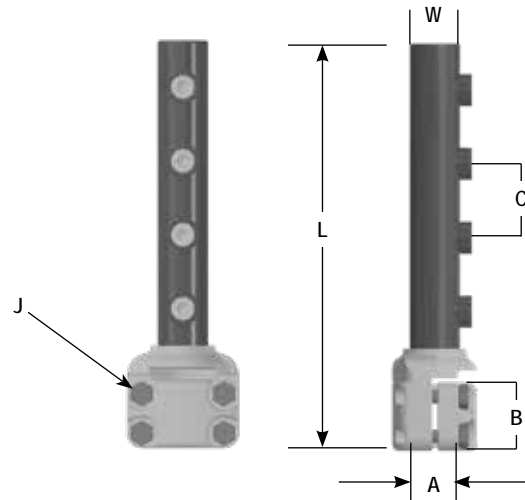

OUTLET RANGE: "A" 6 Str. - 600 kcmil
"B" 2 Str. - 1000 kcmil

Catalog Number	Ampere Capacity	Cable Outlet Arrangement	* No. of Outlets	A		Dimensions in Inches					
				Stud Dia.	Threads per Inch	B	C	J	L	W	
ZMLDN115	1500	All Outlets A	1	1-1/2	12	2.69	—	1/2	8.56	1.94	
ZMLDN215			2	1-1/2	12	2.69	3	1/2	11.56	1.94	
ZMLDN315			3	1-1/2	12	2.69	3	1/2	14.56	1.94	
ZMLDN415			4	1-1/2	12	2.69	3	1/2	17.56	1.94	
ZMLDN515			5	1-1/2	12	2.69	3	1/2	20.56	1.94	
ZMLDN615			6	1-1/2	12	2.69	3	1/2	23.56	1.94	
ZMLDN120	2000		All Outlets B	1	1-1/2	12	2.69	—	1/2	9.06	2.38
ZMLDN220				2	1-1/2	12	2.69	3-1/2	1/2	12.56	2.38
ZMLDN320				3	1-1/2	12	2.69	3-1/2	1/2	16.06	2.38
ZMLDN420				4	1-1/2	12	2.69	3-1/2	1/2	19.56	2.38
ZMLDN520				5	1-1/2	12	2.69	3-1/2	1/2	23.06	2.38
ZMLDN620				6	1-1/2	12	2.69	3-1/2	1/2	26.56	2.38
ZMLDN120B		1		1-1/2	12	2.69	—	1/2	7-7/8	2.38	
ZMLDN220B		2		1-1/2	12	2.69	3-1/2	1/2	11-3/8	2.38	
ZMLDN320B		3		1-1/2	12	2.69	3-1/2	1/2	14-7/8	2.38	
ZMLDN420B		4		1-1/2	12	2.69	3-1/2	1/2	18-3/8	2.38	
ZMLDN520B		5		1-1/2	12	2.69	3-1/2	1/2	21-7/8	2.38	
ZMLDN620B		6		1-1/2	12	2.69	3-1/2	1/2	25-3/8	2.38	

* Can be furnished with more than 6 outlets.

MOLE™ Stud Connector Type ZMLDN (Continued)

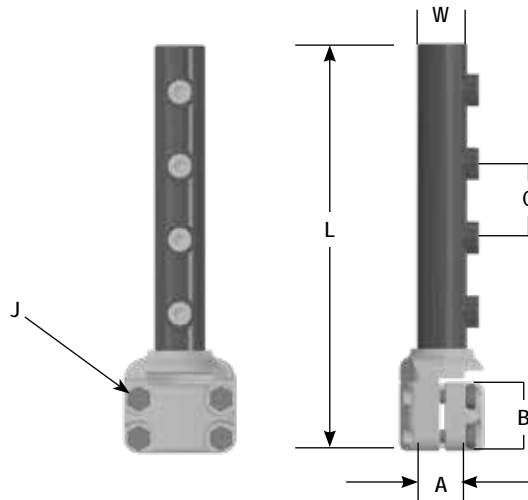

OUTLET RANGE: "A" 6 Str. - 600 kcmil
"B" 2 Str. - 1000 kcmil

Catalog Number	Ampere Capacity	Cable Outlet Arrangement	* No. of Outlets	A		Dimensions in Inches				
				Stud Dia.	Threads per Inch	B	C	J	L	W
ZMLDN125	2500	All Outlets A	1	3	12	3-1/4	—	5/8	8-27/32	3-7/16
ZMLDN225			2	3	12	3-1/4	3-1/2	5/8	12-11/32	3-7/16
ZMLDN325			3	3	12	3-1/4	3-1/2	5/8	15-27/32	3-7/16
ZMLDN425			4	3	12	3-1/4	3-1/2	5/8	19-11/32	3-7/16
ZMLDN525			5	3	12	3-1/4	3-1/2	5/8	22-27/32	3-7/16
ZMLDN625			6	3	12	3-1/4	3-1/2	5/8	26-11/32	3-7/16
ZMLDN125B		All Outlets B	1	3	12	3-1/4	—	5/8	8-27/32	3-7/16
ZMLDN225B			2	3	12	3-1/4	3-1/2	5/8	12-11/32	3-7/16
ZMLDN325B			3	3	12	3-1/4	3-1/2	5/8	15-27/32	3-7/16
ZMLDN425B			4	3	12	3-1/4	3-1/2	5/8	19-11/32	3-7/16
ZMLDN525B			5	3	12	3-1/4	3-1/2	5/8	22-27/32	3-7/16
ZMLDN625B			6	3	12	3-1/4	3-1/2	5/8	26-11/32	3-7/16
ZMLDN130	3000	All Outlets A	1	3	12	3-1/4	—	5/8	7-5/8	4
ZMLDN230			2	3	12	3-1/4	3-3/8	5/8	11-1/4	4
ZMLDN330			3	3	12	3-1/4	3-3/8	5/8	14-5/8	4
ZMLDN430			4	3	12	3-1/4	3-3/8	5/8	18	4
ZMLDN530			5	3	12	3-1/4	3-3/8	5/8	21-3/8	4
ZMLDN630			6	3	12	3-1/4	3-3/8	5/8	24-3/4	4
ZMLDN130B		All Outlets B	1	3	12	3-1/4	—	5/8	7-5/8	4
ZMLDN230B			2	3	12	3-1/4	3-3/8	5/8	11-1/4	4
ZMLDN330B			3	3	12	3-1/4	3-3/8	5/8	14-5/8	4
ZMLDN430B			4	3	12	3-1/4	3-3/8	5/8	18	4
ZMLDN530B			5	3	12	3-1/4	3-3/8	5/8	21-3/8	4
ZMLDN630B			6	3	12	3-1/4	3-3/8	5/8	24-3/4	4

* Can be furnished with more than 6 outlets. For outlet combinations not listed call customer service.

MOLE™ Stud Connector Type Z2MLDN
For Connecting Copper Cables to Network Protector

To terminate two or more cables at the studs of distribution transformers, network protectors, or other apparatus. The body, except for the clamping element, is completed insulated. A separate clamping cap over the stud is provided that permits easy removal of the MOLE™ Stud Connector. This permits work to be done on the Network Protector without unduly disturbing the cables.

Outlet Plugs — MOLE™ outlet plugs that facilitate sealing outlets not being used are available. Type Z-P and Type K-P, sold separately.

Insulating Sleeves — Taping operations for watertight joints are greatly simplified by the use of BURNDY® Type CM or MOLE™ Insulating Sleeves Type Z-C, sold separately.

Clamping Elements — Outlet Symbols A or B, refer to socket and nut Type Z-NR, and Cone Type Z cable clamping elements accommodated. These must be ordered separately.

OUTLET RANGE: **"A" 6 Str. - 600 kcmil**
 "B" 2 Str. - 1000 kcmil

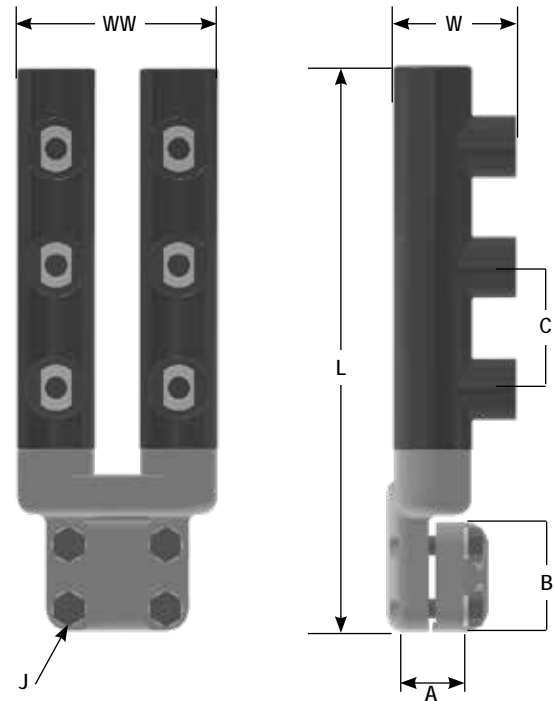

Catalog Number	Ampere Capacity	Cable Outlet Arrangement	*No. of Outlets	A		Dimensions in Inches					
				Stud Dia.	Threads per Inch	B	C	J	L	W	WW
Z2MLDN20	2000 & Smaller	All Outlets A	2	1-1/2	12	2-11/16	—	1/2	8	3	5-3/16
Z2MLDN40			4	1-1/2	12	2-11/16	3	1/2	11	3	5-3/16
Z2MLDN620			6	1-1/2	12	2-11/16	3	1/2	14	3	5-3/16
Z2MLDN230	2500 & 3000	All Outlets A	2	3	12	3-1/4	—	5/8	9	3	6-1/2
Z2MLDN430			4	3	12	3-1/4	3	5/8	12	3	6-1/2
Z2MLDN630			6	3	12	3-1/4	3	5/8	15	3	6-1/2
Z2MLDN230B		All Outlets B	2	3	12	3-1/4	—	5/8	9	3-1/2	6-1/2
Z2MLDN430B			4	3	12	3-1/4	3-1/2	5/8	12-1/2	3-1/2	6-1/2
Z2MLDN630B			6	3	12	3-1/4	3-1/2	5/8	16	3-1/2	6-1/2

*Can be furnished with more than 6 outlets. For outlet combinations not listed call customer service.

MOLE™ Stud Connector Type ZMDN For Connecting Copper Cables to Network Protector

To terminate one or more cables at the studs of distribution transformers, network protectors, or other apparatus. The body, except for the clamping element, is completed insulated. A separate clamping cap over the stud is provided that permits easy removal of the MOLE™ Stud Connector. This permits work to be done on the Network Protector without unduly disturbing the cables.

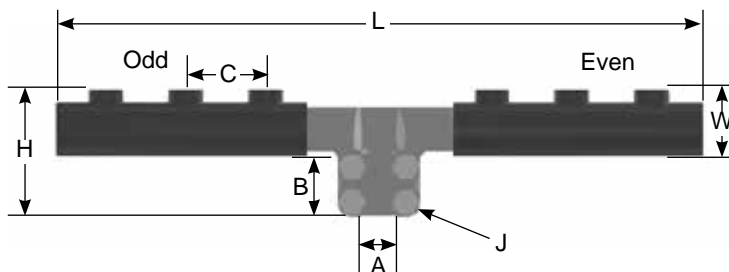

Outlet Plugs — MOLE™ outlet plugs that facilitate sealing outlets not being used are available. Type Z-P and Type K-P, sold separately.

Insulating Sleeves — Taping operations for watertight joints are greatly simplified by the use of BURNDY® Type CM or MOLE™ Insulating Sleeves Type Z-C, sold separately.

Clamping Elements — Outlet Symbols A or B, refer to socket and nut Type Z-NR, and Cone Type Z cable clamping elements accommodated. These must be ordered separately.

OUTLET RANGE: **"A" 6 Str. - 600 kcmil**
 "B" 2 Str. - 1000 kcmil

Catalog Number	Ampere Capacity	Cable Outlet Arrangement	*No. of Outlets	A		Dimensions in Inches					
				Stud Dia.	Threads per Inch	B	C	J	H	L	W
ZMDN320	2000 & Smaller	All Outlets A	3	1-1/2	12	2-11/16	3-1/2	1/2	8-1/16	11-1/2	3-7/16
ZMDN420			4	1-1/2	12	2-11/16	3-1/2	1/2	8-1/16	15	3-7/16
ZMDN520			5	1-1/2	12	2-11/16	3-1/2	1/2	8-1/16	18-1/2	3-7/16
ZMDN620			6	1-1/2	12	2-11/16	3-1/2	1/2	8-1/16	22	3-7/16
ZMDN320B		All Outlets B	3	1-1/2	12	2-11/16	3-1/2	1/2	8-1/16	11-1/2	3-7/16
ZMDN420B			4	1-1/2	12	2-11/16	3-1/2	1/2	8-1/16	15	3-7/16
ZMDN520B			5	1-1/2	12	2-11/16	3-1/2	1/2	8-1/16	18-1/2	3-7/16
ZMDN620B			6	1-1/2	12	2-11/16	3-1/2	1/2	8-1/16	22	3-7/16
ZMDN325	2000 Through 2500	All Outlets A	3	3	12	3-1/4	3-1/2	5/8	8-5/8	11-1/2	3-7/16
ZMDN425			4	3	12	3-1/4	3-1/2	5/8	8-5/8	15	3-7/16
ZMDN525			5	3	12	3-1/4	3-1/2	5/8	8-5/8	18-1/2	3-7/16
ZMDN625			6	3	12	3-1/4	3-1/2	5/8	8-5/8	22	3-7/16

*Can be furnished with more than 6 outlets. For outlet combinations not listed call customer service.
For connectors with an odd number of outlets the odd and even split of outlets will be as indicated in the diagram.

MOLE™ Stud Connector Type ZMTDN

For Connecting Copper Cables to Network Protector

To terminate two or more cables at the studs of distribution transformers, network protectors, or other apparatus. The body, except for the clamping element, is completed insulated. A separate clamping cap over the stud is provided that permits easy removal of the MOLE™ Stud Connector. This permits work to be done on the Network Protector without unduly disturbing the cables.



Catalog Number	Ampere Capacity	Number of Outlets	Cable Outlet Arrangement	Stud Dia. (12 threads/inch)
ZMTDN815	1500	8	A	1.50"
ZMTDN1015	1500	10	A	1.50"
ZMTDN820	2000-2500	8	A	1.50"
ZMTDN1025	2000-2500	10	A	3.00"

MOLE™ Outlet Plugs, Type Z-P

For MOLE™ Outlets not in use

These outlet plugs facilitate sealing MOLE™ outlets not currently being used.

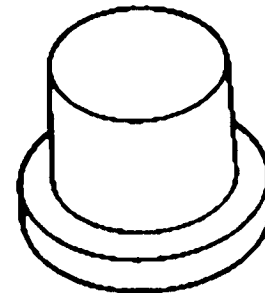

Catalog Number	Used On Outlet Size
Z29P	A
Z34P	B
Z40P	C

Socket and Nut Assembly Type Z-NR

For Use with MOLE™

Designed for use with the BURNDY® MOLE™ connectors. With the use of the proper compression cones, 14 sizes take a range of cables from #6 to 1000 kcmil. The compact design helps in easy, effective taping. Insulating sleeves are available to keep taping to a minimum.

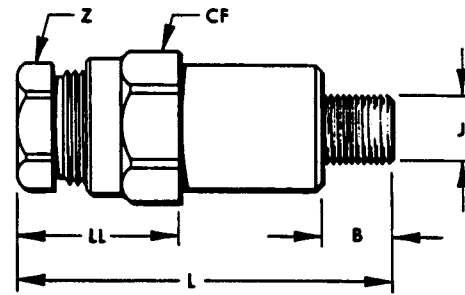

OUTLET RANGE: “A” 6 Str. - 600 kcmil
 “B” 2 Str. - 1000 kcmil

Catalog Number	To be Used in MOLE™ Outlet Size	Maximum Cable Accommodated by Socket	Stud Size J	Dimensions in Inches				
				B	CF (Cross Flats)	L	LL	Z (Cross Flats)
Z28NR	A	4/0 Str.	5/8-18	17/32	1-1/8	3-7/16	1-1/2	7/8
Z29NR		250 kcmil	5/8-18	17/32	1-3/16	3-9/16	1-5/8	15/16
Z30NR		300 kcmil	5/8-18	17/32	1-1/4	3-5/8	1-11/16	1
Z32NR		400 kcmil	5/8-18	17/32	1-3/8	3-5/8	1-11/16	1-1/8
Z34NR		500 kcmil	5/8-18	17/32	1-1/2	3-11/16	1-3/4	1-1/4
Z36NR		600 kcmil	5/8-18	17/32	1-1/2	3-13/16	1-7/8	1-5/16
Z40NRA ①	B	800 kcmil	5/8-18	17/32	1-13/16	5-17/32	2-1/4	1-1/2
Z34NRB ②		500 kcmil	7/8-14	11/16	1-1/2	3-11/16	1-3/4	1-1/4
Z40NR		800 kcmil	7/8-14	11/16	1-13/16	4-3/8	2-1/4	1-1/2
Z44NR		1000 kcmil	7/8-14	11/16	1-15/16	6-1/16	2-7/16	1-5/8
Z46NR	C	1500 kcmil	1-1/8-12	13/16	2-1/8	6-7/8	2-13/16	2-1/4
Z47NR		1750 kcmil	1-1/8-12	13/16	2-1/4	7-3/16	2-7/8	2-3/8

① Uses Insulating Sleeve Z104C4434

② Uses Insulating Sleeve Z88C3429

MOLE™ Compression Cone Type Z
For Concentric and Compressed Conductor

For use with Socket and Nut Assembly, the Z Cone is machined to close tolerances to provide maximum secureness in gripping a wide range of cable sizes. Annular grooves in the inner barrel of the cone serve to further accomplish this result.

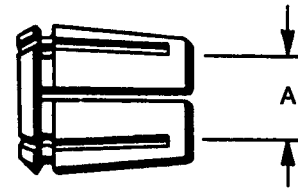

Catalog Number	Cable Size	For Use with Socket & Nut Assembly	A	
			Inches	
Z6C28	#6 Str.	Z28NR	0.18 in	
Z4C28	#4 Str.		0.23 in	
Z2C28	#2 Str.		0.29 in	
Z2528	1/0 Str.		0.37 in	
Z2728	3/0 Str.		0.47 in	
Z2828	4/0 Str.		0.53 in	
Z6C29	#6 Str.		Z29NR	0.18 in
Z4C29	#4 Str.	0.23 in		
Z2C29	#2 Str.	0.29 in		
Z1C29	#1 Str.	0.33 in		
Z2529	1/0 Str.	0.37 in		
Z2629	2/0 Str.	0.42 in		
Z2829	4/0 Str.	0.53 in		
Z2929	250 kcmil	0.58 in		
Z6C30	#5 Str.	Z30NR		0.18 in
Z4C30	#4 Str.			0.23 in
Z2C30	#2 Str.		0.29 in	
Z1C30	#1 Str.		0.33 in	
Z2530	1/0 Str.		0.37 in	
Z2630	2/0 Str.		0.42 in	
Z2730	3/0 Str.		0.47 in	
Z2830	4/0 Str.		0.53 in	
Z2930	250 kcmil		0.58 in	
Z3030	300 kcmil		0.63 in	
Z2C32	#2 Str.		Z32NR	0.29 in
Z1C32	#1 Str.			0.33 in
Z2532	1/0 Str.			0.37 in
Z2632	2/0 Str.	0.42 in		
Z2732	3/0 Str.	0.47 in		
Z2832	4/0 Str.	0.53 in		
Z2932	250 kcmil	0.58 in		
Z3032	300 kcmil	0.63 in		
Z3132	350 kcmil	0.68 in		
Z3232	400 kcmil	0.73 in		
Z2C34	#2 Str.	Z34NR & Z34NRB	0.29 in	
Z1C34	#1 Str.		0.33 in	
Z2534	1/0 Str.		0.37 in	
Z2634	2/0 Str.		0.42 in	
Z2734	3/0 Str.		0.47 in	

Catalog Number	Cable Size	For Use with Socket & Nut Assembly	A
			Inches
Z2834	4/0 Str.	Z34NR & Z34NRB	0.53 in
Z2934	250 kcmil		0.58 in
Z3034	300 kcmil		0.63 in
Z3134	350 kcmil		0.69 in
Z3234	400 kcmil		0.73 in
Z3334	450 kcmil		0.76 in
Z3434	500 kcmil		0.81 in
Z2936	250 kcmil	Z36NR	0.58 in
Z3036	300 kcmil		0.63 in
Z3136	350 kcmil		0.69 in
Z3236	400 kcmil		0.73 in
Z3336	450 kcmil		0.76 in
Z3436	500 kcmil		0.81 in
Z3536	550 kcmil		0.86 in
Z3636	600 kcmil		0.89 in
Z2940	250 kcmil	Z40NR & Z40NRA	0.58 in
Z3040	300 kcmil		0.63 in
Z3140	350 kcmil		0.69 in
Z3240	400 kcmil		0.73 in
Z3340	450 kcmil		0.76 in
Z3440	500 kcmil		0.81 in
Z3540	550 kcmil		0.86 in
Z3640	600 kcmil		0.89 in
Z3740	650 kcmil		0.92 in
Z3840	700 kcmil		0.97 in
Z3940	750 kcmil	1.00 in	
Z4040	800 kcmil	1.03 in	
Z3444	500 kcmil	Z44NR	0.81 in
Z3544	550 kcmil		0.86 in
Z3644	600 kcmil		0.89 in
Z3744	650 kcmil		0.92 in
Z3844	700 kcmil		0.97 in
Z3944	750 kcmil		1.00 in
Z4044	800 kcmil		1.03 in
Z4144	850 kcmil		1.06 in
Z4244	900 kcmil		1.09 in
Z4344	950 kcmil		1.12 in
Z4444	1000 kcmil	1.15 in	
Z4646	1500 kcmil	Z46NR	1.41 in
Z4747	1750 kcmil	Z47NR	1.53 in

MOLE™ Compression Cone Type Z For Compact Conductor

For use with Socket and Nut Assembly, the Z Cone is machined to close tolerances to provide maximum secureness in gripping a wide range of cable sizes. Annular grooves in the inner barrel of the cone serve to further accomplish this result.

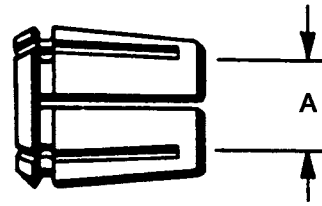

Compact Stranded Copper Cable			
Type Z Cone	Socket and Nut Assembly	Compact Cable Size	Nominal Conductor Diameter
Z3C28	Z28NR	#2	0.268
Z2C28		#1	0.299
Z1C28		1/0	0.336
Z2528		2/0	0.376
Z2628		3/0	0.423
Z2728		4/0	0.475
Z2C29		Z29NR	#1
Z1C29	1/0		0.336
Z2529	2/0		0.376
Z2629	3/0		0.423
Z2729	4/0		0.475
Z2829	250 kcmil		0.520
Z2929	300 kcmil		0.570
Z1C30	Z30NR	1/0	0.336
Z2530		2/0	0.376
Z2630		3/0	0.423
Z2730		4/0	0.475
Z2830		250 kcmil	0.520
Z2930		300 kcmil	0.570
Z1C32		Z32NR	1/0
Z2532	2/0		0.376
Z2632	3/0		0.423
Z2732	4/0		0.475
Z2832	250 kcmil		0.520
Z2932	300 kcmil		0.570
Z3232	500 kcmil		0.736
Z2534	Z34NR	2/0	0.376
Z2634		3/0	0.423
Z2734		4/0	0.475
Z2834		250 kcmil	0.520
Z2934		300 kcmil	0.570
Z3234		500 kcmil	0.736
Z3334		550 kcmil	0.775
Z3434	600 kcmil	0.813	

Compact Stranded Copper Cable				
Type Z Cone	Socket and Nut Assembly	Compact Cable Size	Nominal Conductor Diameter	
Z2536	Z36NR	2/0	0.376	
Z2636		3/0	0.423	
Z2736		4/0	0.475	
Z2836		250 kcmil	0.520	
Z2936		300 kcmil	0.570	
Z3236		500 kcmil	0.736	
Z3336		550 kcmil	0.775	
Z3436		600 kcmil	0.813	
Z3636		750 kcmil	0.908	
Z2640		Z40NR	3/0	0.423
Z2740	4/0		0.475	
Z2840	250 kcmil		0.520	
Z2940	300 kcmil		0.570	
Z3240	500 kcmil		0.736	
Z3340	550 kcmil		0.775	
Z3440	600 kcmil		0.813	
Z3640	750 kcmil		0.908	
Z2844	Z44NR		250 kcmil	0.520
Z2944			300 kcmil	0.570
Z3244		500 kcmil	0.736	
Z3344		550 kcmil	0.775	
Z3444		600 kcmil	0.813	
Z3644		750 kcmil	0.908	

MOLE™ Coupler, Type ZMS
 For Connecting Multiple MOLE™ Connectors

A compact, easy-to-tape MOLE™ Coupler for joining multiple MOLE™ end-to-end. Allows for expansion of underground systems by joining more MOLE™ Connectors to existing MOLE™ installations. Easy assembled to the end outlets of MOLE™ Connectors Types ZMT, ZMX, ZML, and ZMK. Can also be used in side outlets for other types of MOLE™ arrangements. The MOLE™ Coupler has a lock nut feature which permits pre-positioning of the added MOLE™ and facilitates training of new cables. Makes an effective electrical and mechanical connection.

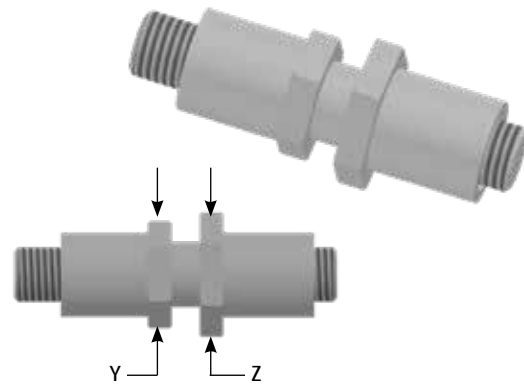

OUTLET RANGE: **“A” (5/8”) 6 Str. - 600 kcmil**
 “B” (7/8”) 2 Str. - 1000 kcmil
 “C” (1-1/8”) 500 - 1500 kcmil

MOLE™ Outlet Size	MOLE™ Coupler	MOLE™ Coupler Ampere Capacity	Dimensions in Inches		
			Overall Length	Cross Flats	
				Y	Z
A	ZMS29	1200	4-21/32	1-3/16	1-3/8
B	ZMS34	1600	5-7/32	1-1/2	1-3/4
C	ZMS40	2000	5-3/4	1-3/4	2-1/8

MOLE™ Outlet Insulating Sleeve, Type Z-C

Aid in insulating MOLE™ Outlets to produce watertight joint with minimal taping

An effective aid in insulating MOLE™ outlets to produce a secure watertight joint with a minimum of taping. Fits over the MOLE™ outlet and over the maximum outer diameter of insulated cable. The difference between the I.D. of the standard sleeve and the O.D. of the cable insulation is taken up by wrapping the cable with several turns of rubber tape. The only external taping required to effectively seal the joint is the small area at each end of the sleeve.

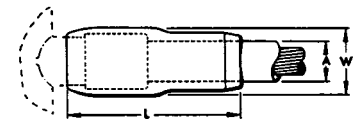

Fig. 1

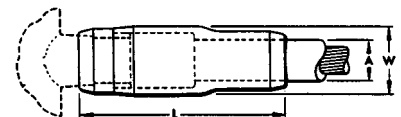

Fig. 2

Catalog Number	For Use with Socket and Nut Assemblies	Fig. No.	Dimensions in Inches		
			*A (Max.)	L	W
Z72C3029	Z28NR Z29NR Z30NR	1	1-1/8	4-3/4	1-7/8
Z88C3429	Z32NR Z34NR Z34NRB Z36NR	1	1-3/8	5-3/16	2-1/8
Z104C4034	Z40NR	1	1-5/8	5-13/16	3-5/6
Z104C4434	Z44NR Z40NRA	2	1-5/8	7-3/16	3-5/6
Z144C4840	Z45NR Z46NR Z47NR Z48NR	2	2-1/4	9-5/16	3-1/2

* Build up insulation of MOLE™ Joint with rubber tape to equal inner diameter of Insulating Sleeve, for insulating sleeve with inner diameter other than standard call customer service.

This page intentionally left blank

HYCRAB™ Connectors

One of the most economical devices for connecting several cables to a common junction point is the HYCRAB™, which is essentially a bus bar with a number of compression-type connector outlets, pre-insulated to eliminate taping. Like the MOLE™, the HYCRAB™ fits into a limited space, is simple to rack, and facilitates adding future cables.

Insert and Insulation

Having an insert similar to that of the MOLE™, the HYCRAB™, has connector outlets of the BURNDY® HYDENT™ compression type. These tubular elements are indented to the cable by BURNDY® HYPRESS™ installation tools and dies, designed to compress connector and cable together with indents of controlled depth. HYDENT™ compression connections are made quickly and easily, have relative conductivities of 100% or higher, are electrically stable, and mechanically secure.

The HYCRAB™ is insulated by a jacket of molded rubber to resist prolonged exposure to oil or other contaminants.

Installation

Insulation fingers are rolled back to expose the tubular outlets, sufficiently spaced to allow for the convenient operation of BURNDY® HYPRESS™ compression tools. Cable ends are inserted into the outlets. Each is crimped with one or two indents, and the fingers are rolled forward again to cover the outlets. Installation is completed by tapping the short space between the tip of the finger and cable insulation.

Variations and Accessories

Uninsulated HYCRAB™ connectors for joining bare neutral cables are available in the same range of sizes and number of outlets as the insulated HYCRAB™. By using reducing adapters, the HYCRAB™ can accommodate service wires as small as #6, in addition to the 4/0 or 500 kcmil cable sizes for which these connectors are ordinarily used.

Type YM Insulated HYCRAB™

A compact insulated crab joint for connecting underground cables at junction points. Two outlets, one on either side of the HYCRAB™ body, are ready for immediate use. All other outlets are sealed with vulcanized rubber plugs which are easily removed when future installations are made. This unit eliminates bulky, difficult crotch taping. By using Reducing Adapters (Type Y-R), the HYCRAB™ can be installed on cable sizes from #6 to 500 kcmil (e.g.: use Y3428R to install 4/0 into YM4-34).

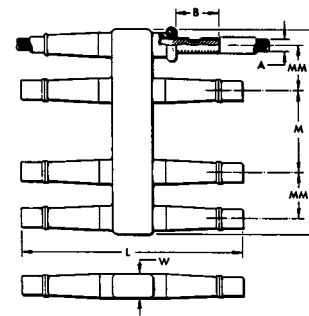

Catalog Number	Cable Size A	# of Outlets	Dimension in Inches						Installation Information	
									HYPRESS™ & Indentor Die	# of Indents
			Y34BH with Y34PR							
			Nest Die							
B	H	L	M	MM	W					
YM428	4/0 Str.	4	2	3-11/16	10-3/16	—	2-3/16	1-1/8	B28D	1
YM628		6	2	7-9/16	10-3/16	3-7/8	2-3/16	1-1/8	B28D	1
YM828		8	2	9-3/4	10-3/16	3-7/8	2-3/16	1-1/8	B28D	1
YM1028		10	2	13-1/2	8-3/4	3-1/2	2-1/2	1-1/8	B28D	1
YM1228		12	2	16	8-3/4	3-1/2	2-1/2	1-1/8	B28D	1
YM434	500 kcmil	4	2-1/2	4-3/8	12-5/8	—	2-3/8	1-1/2	No Nest Die Required. Use Indentor Only.	2
YM634		6	2-1/2	8-5/8	12-5/8	4-1/4	2-3/8	1-1/2		2
YM834		8	2-1/2	11	12-5/8	4-1/4	2-3/8	1-1/2		2
YM1034		10	2-1/2	14-1/2	12-1/2	3-3/4	2-1/2	1-1/2		2
YM1234		12	2-1/2	17	12-1/2	3-3/4	2-1/2	1-1/2		2

HYCRAB™ Connector, Type ZNM For Joining Bare Neutral Cables

A compact uninsulated multiple connector for joining bare neutral underground cables. For insulated crab joints, see HYCRAB™, Type YM. Reducing adapters (Type Y-R) permit the HYCRAB™ products listed below to take a full range of cable sizes from #6 to 500 kcmil. For proper installation see table below.

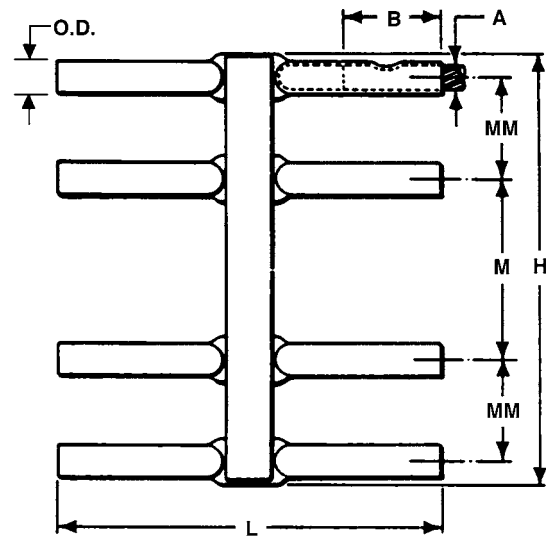

Catalog Number	Cable Size A	No. of Outlets	Dimension in Inches						Installation Information	
									HYPRESS™ & Indentor Die	No. of Indents
			Y34BH with Y34PR	Nest Die						
B	H	L	M	MM	O.D.					
YNM428	4/0 Str.	4	2	3-3/16	8-3/16	—	2-3/16	11/16	B28D	1
YNM628		6	3-1/8	7-1/6	8-3/16	3-7/8	2-3/16	11/16	B28D	1
YNM828		8	2	9-1/4	8-3/16	3-7/8	2-3/16	11/16	B28D	1
YNM434	500 kcmil	4	2-1/2	3-15/16	10-5/8	—	2-3/8	1-1/16	No Nest Die Required. Use Indentor Only.	2
YNM634		6	2-1/2	8-3/16	10-5/8	4-1/4	2-3/8	1-1/16		2
YNM834		8	2-1/2	10-9/16	10-5/8	4-1/4	2-3/8	1-1/16		2

* Bare HYCRAB™ can be furnished to accommodate both 4/0 and 500 kcmil cables.

Network Protection

The primary purpose of network protection is the controlled interruption of fault currents before damage occurs to cable insulations and associated equipment, and the elimination of unnecessary service interruptions. The limiter and fuses for network protection are closely associated with the connectors and are equally vital to the safe, continuous operation of an underground system.

BURNDY has developed protective devices that have played a major role in reducing underground system outages and the subsequent expenses incurred in the loss of service and replacement of damaged cables. A basic objective has been the design of limiter-connector combinations that, in addition to protecting against the effects of fault currents, economize on both space and installation costs.

Limiters are designed to protect underground secondary cable from damage by fault currents of two principal kinds: high energy arcing faults and sustained faults. The arcing fault, usually of shorter duration and lesser intensity, is more common. While this type of fault may sputter briefly and then clear, some may be sustained long enough to "roast" the insulation.

A sustained fault occurs when two conductors come solidly into contact and permit the flow of heavy short-circuit currents. Without suitable protection, these fault currents are heavy enough to damage cable insulation and often produce combustible fumes accompanied by fire and explosion.

Installed at each end of cable sections, limiters have time-current characteristics designed to avoid unnecessary outages. Network protector fuses, installed in the network protector on the load side of the breaker, provide back-up protection against failure of a network protector to open on a primary fault. Coordinated characteristics of limiters and fuses provide for fault currents to be interrupted before they can cause damage, but only under predetermined time-current conditions, and only in those parts of the system where interruption is necessary.

Limiters

Engineered to interrupt the circuit before cables carrying a fault current are usually damaged, limiters act to confine damage to the section of cable where the fault occurred. The limiters are designed to prevent unnecessary clearing and will "hang on" during:

1. Faults with wold clear without damaging cable insulation
2. Overloads from motor starting, load transfer because of primary fault, or temporary overload during fault conditions
3. Overloads from loss of secondary conductors caused by clearing of other limiters
4. Reverse current flow through the network protector on primary faults
5. Faults on other secondary cables

For proper proection BURNDY® limiters are designed with time-current characteristics approximating the insulation damage curve of the cable with which they will be used. Figure 4 shows time-current characteristic curves for a range of standard (250 volt) limiters, superimposed on insulation damage curves for several cable sizes. Although the limiter curve crosses the insulation damage curves, in practice the limiters will blow before the insulation can deteriorate.

The insulation damage characteristics represent three phases equally loaded in a duct. Since low-current faults seldom affect more than one phase at a time, the rate of heat generated in the conduit is much less than for a balanced 3-phase fault, and the time to reach the damage point is appreciably longer. Practical experience confirms that limiters provide protection during low-current, as well as high-current faults.

Construction

The limiter is essentially a compression-type electrical connector with its center section accurately formed to provide a fusible element. This fusible element is enclosed in a molded ceramic shell and the assembly encased in an insulated sleeve.

Interrupting capacities are as follows:

Standard Limiters: 30,000 amps at 250V

Replaceable-Link Limiters: 20,000 amps at 250V

The protection probably lies in the fact that the fault impedance reduces the actual fault current to a value considerably less than calculated.

Replaceable-Link Limiters

Replaceable-link limiters, which provide faster time-current characteristics (Figure 5), are used in smaller networks, on the fringes of larger networks, at points where radial feeders leave a network, and for fusing service cables. As its name implies, this limiter is also distinctive in that its fusible link is replaceable.

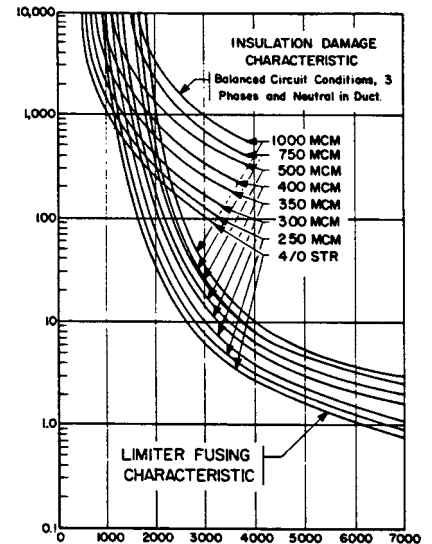

Figure 4: Current - Amperes Standard 250 Volt Limiters

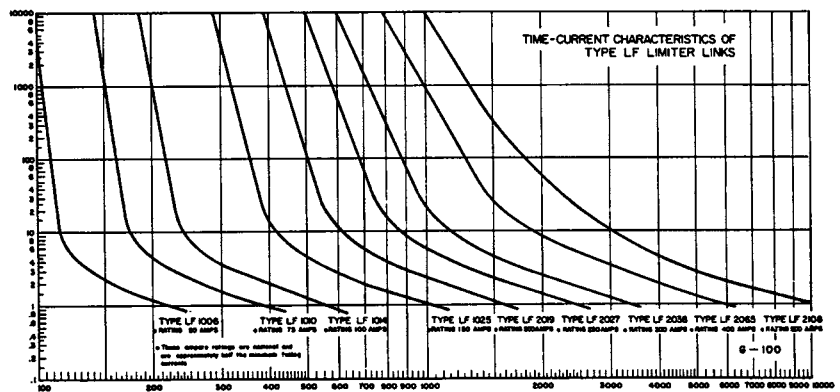

Figure 5: Current in Amperes Replaceable-link Limiters

Network Protection (Continued)

Limiter Variations

The Limiter Lug provides a fusible connection between a cable and a flat surfaced terminal of a transformer or other apparatus. The Limiter Tap incorporates a Limiter Lug assembly, modified to terminate cable to a ring bus. This straight Limiter is made for installation in a single conductor cable. The Molimiter is a Limiter designed so that one end is crimped onto a cable and the other fits the clamping element of a MOLE™ outlet. The Limiter HYCRAB™ connector is essentially a HYCRAB™ with a fusible section in each of its outlets.

Network Protector Fuses

Type Y and Z Network Protector Fuses provide back-up protection in case the protector breaker fails to operate during a primary fault. The fuse time-current curves (Figure 7), are similar to those of the limiter, thus permitting correct fuse-limiter coordination for complete network protection.

Design and Construction

The fusible element for a Type Y or Type Z Fuse is a tin-plated copper bar with reduced section, encased in an arc-resistant molded ceramic enclosure. One-piece construction eliminates possibility of joint failure and assures maximum reliability.

Limiter-Fuse Coordination

To isolate a fault before it can cause extensive damage, and without interrupting service in other sections of the network, limiters and fuses must clear at the proper time and in proper sequence, depending on the fault's location in the primary or secondary system. When a primary fault occurs, the fuse should clear before any

limiters blow. For a secondary fault, limiters should clear the fault before the network protector fuse opens. Failure of limiters and network protector fuses to function in proper sequence could cause cascading of other Fuses, or clearing of secondary faults by Fuses rather than limiters. Premature blowing of Limiters not in the faulted section could cause unnecessary service interruption in sections remote from the fault.

To assure the coordinated functioning of fuses and limiters throughout a system, proper rating must be selected. The four-step "Coordination Study" (Figure 8) used in a 4-parallel cable feed system from the protector to the first secondary junction is a typical example of how to select proper ratings.

1. Plot the damage characteristic curve of the cable insulation in the system. Curves for Class L620 (260° C or 500° F), appear in Figure 5.
2. Plot the time-current characteristic curve of the same limiter in Parallel secondary mains, assuming it carries 40% of total backfeed current. Allowing for the possibility of unequal current distribution of secondary mains, the "40% Cable Limiter Curve" provides a conservative basis for selection of network protector fuses.
3. Select a fuse with its time-current characteristics (Figure 7) lying between the limiter curves plotted in steps 2 and 3.

This procedure avoids the selection of fuses so light that they might overheat the network protector or clear unnecessarily, possibly cascading other fuses in the network; or so heavy that transformer secondaries might be damaged or limiters blow before the fuse. Proper limiter-fuse coordination, facilitated by the use of fuses and limiters that are precisely matched, assures effective protection without unnecessary interruption.

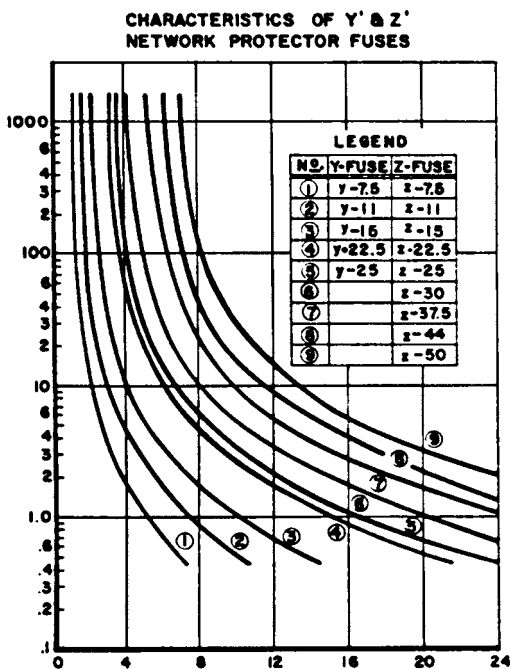

Figure 7: Amperes in Thousands

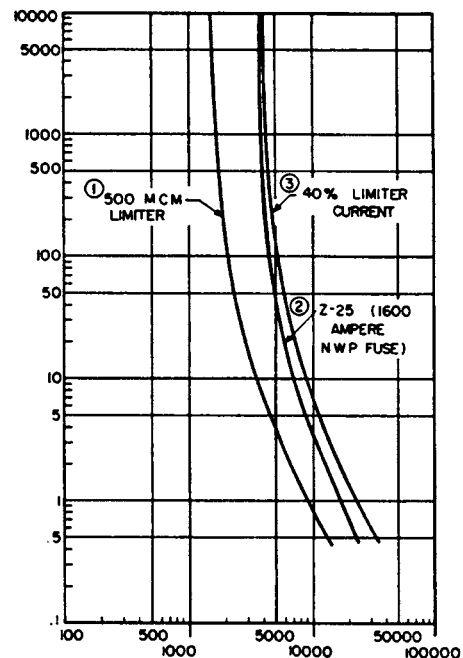
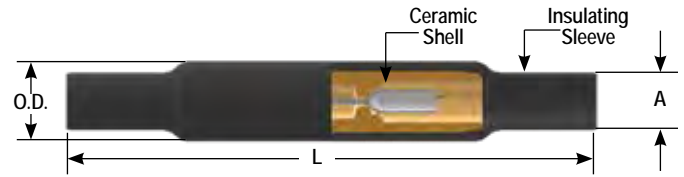

Figure 8: Current in Amperes

Limiter Assembly, Types YFS-CR, YFS-CP
With Ceramic Shell and Rubber Sleeve for Insulated Cables

The Limiter combines the functions of fuse and connector. The fusible element which is an integral part of the connector will clear faults that are great enough to cause damage to the cable insulation. However it will not clear on minor overloads of short duration. Fusing characteristics of the limiter are shown in technical section. For HYPRESS™ installation, see table below.



For conductor sizes not listed call customer service.

To specify a fast acting limiter in any configuration insert an "F" before the conductor number (e.g., YFSF34CR specifies a 1/2 thick limiter section).

*Paper Insulated Cable - Oil Tight Cable Sockets.

- ① Y35P3 Indentor Adaptor required for Y34PR Indentor
- ② Catalog number PUADP1 Adaptor is required to use "U" type dies in the 46 series tools
- ③ Catalog number PT6515 Adaptor is required to use "U" type dies in the 45 series tools

For Use On		Cable Size	Dimensions in Inches			Installation Tooling (# Crimps)							
Rubber Insulated Cable	Paper Insulated Cable*		Max. Cable Dia. over Insulation A	L	O.D.	Die Information		Hydraulic					
Catalog Number						Die Index	Type ①	Y34A	35, 750 Series	46 Series ②	45 Series ③	Y48B	60 Series
YFS28CR	YFS28CP	4/0 Str.	1	12-3/4	1-15/16	15	Purple Die Set	—	U28RT (2)	U28RT (2)	U28RT (2)	C28R (2)	L28RT (1)
							Nest Indentor	A28D (1) Y34PR	U28D1 (1) Y34PR	U28D1 (1) Y34PR	U28D1 (1) Y34PR	C28D (1) Y48PR	—
YFS29CR	YFS29CP	250 kcmil	1	12-3/4	1-15/16	16	Yellow Die Set	—	U29RT (2)	U29RT (2)	U29RT (2)	C29R (2)	L29RT (1)
							Nest Indentor	A29D (2) Y34PR	U29D1 (2) Y34PR	U29D1 (2) Y34PR	U29D1 (2) Y34PR	C29D (1) Y48PR	—
YFS30CR	YFS30CP	300 kcmil	1-1/8	13-1/2	2-3/16	17	White Die Set	—	U30RT (4)	U30RT (4)	U30RT (4)	C30R (1)	L30RT (1)
							Nest Indentor	A30D (2) Y34PR	U30D1 (2) Y34PR	U30D1 (2) Y34PR	U30D1 (2) Y34PR	C30D (2) Y48PR	—
YFS31CR	YFS31CP	350 kcmil	1-1/8	13-1/2	2-3/16	18	Red Die Set	—	U31RT (4)	U31RT (4)	U31RT (4)	C31R (1)	L31RT (1)
							Nest Indentor	A31D (2) Y34PR	U31D1 (2) Y34PR	U31D1 (2) Y34PR	U31D1 (2) Y34PR	C31D (1) Y48PR	—
YFS32CR	YFS32CP	400 kcmil	1-1/8	13-1/2	2-3/16	19	Blue Die Set	—	U32RT (4)	U32RT (4)	U32RT (4)	C32R (1)	L32RT (1)
							Nest Indentor	A32D (2) Y34PR	U32D1 (2) Y34PR	U32D1 (2) Y34PR	U32D1 (2) Y34PR	C32D (2) Y48PR	—
YFS34CR	YFS34CP	500 kcmil	1-11/32	15-7/8	2-3/8	20	Brown Die Set	—	U34RT (4)	U34RT (4) P34RT (4)	U34RT (4)	C34R (2)	L34RT (2)
							Nest Indentor	A34D (2) Y34PR	U34D1 (2) Y34PR	U34D1 (2) Y34PR	U34D1 (2) Y34PR	C34D (2) Y48PR	—

Long Limiter Assembly, Type YFS-CPL With Ceramic Shell and Rubber Sleeve for Paper-Lead Cables

The Long Limiter performs the same functions as the Limiter shown, Types YFS-CR and YFS-CP. It differs in that it has extra long cable sockets which are preferred by some for use on paper insulated cable. The end seams are sealed to make the sockets oil tight. Fusing characteristics of the Limiter are shown in technical section. For proper HYPRESS™ installation, see table below.

For conductor sizes not listed call customer service.

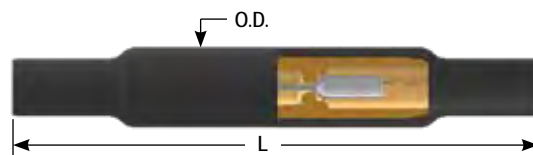

To specify a fast acting limiter in any configuration insert an "F" before the conductor number (e.g., YFSF34CR specifies a 1/2 thick limiter section).

- ① Y35P3 Indentor Adaptor required for Y34PR Indentor
- ② Catalog number PUADP1 Adaptor is required to use "U" type dies in the 46 series tools
- ③ Catalog number PT6515 Adaptor is required to use "U" type dies in the 45 series tools

Catalog Number	Cable Size	Dimensions in Inches			Installation Tooling (# Crimps)							
		Max. Cable Dia. over Insulation A	L	O.D.	Die Information		Hydraulic					
					Die Index	Type ①	Y34A	35, 750 Series	46 Series ②	45 Series ③	Y48B	60 Series
YFS28CPL	4/0 Str.	1	12-3/4	1-15/16	15	Purple Die Set	—	U28RT (2)	U28RT (2)	U28RT (2)	C28R (2)	L28RT (1)
						Nest Indentor	A28D (1) Y34PR	U28D1 (1) Y34PR	U28D1 (1) Y34PR	U28D1 (1) Y34PR	C28D (1) Y48PR	—
YFS29CPL	250 kcmil	1	12-3/4	1-15/16	16	Yellow Die Set	—	U29RT (2)	U29RT (2)	U29RT (2)	C29R (2)	L29RT (1)
						Nest Indentor	A29D (2) Y34PR	U29D1 (2) Y34PR	U29D1 (2) Y34PR	U29D1 (2) Y34PR	C29D (1) Y48PR	—
YFS30CPL	300 kcmil	1-1/8	13-1/2	2-3/16	17	White Die Set	—	U30RT (4)	U30RT (4)	U30RT (4)	C30R (1)	L30RT (1)
						Nest Indentor	A30D (2) Y34PR	U30D1 (2) Y34PR	U30D1 (2) Y34PR	U30D1 (2) Y34PR	C30D (2) Y48PR	—
YFS31CPL	350 kcmil	1-1/8	13-1/2	2-3/16	18	Red Die Set	—	U31RT (4)	U31RT (4)	U31RT (4)	C31R (1)	L31RT (1)
						Nest Indentor	A31D (2) Y34PR	U31D1 (2) Y34PR	U31D1 (2) Y34PR	U31D1 (2) Y34PR	C31D (1) Y48PR	—
YFS32CPL	400 kcmil	1-1/8	13-1/2	2-3/16	19	Blue Die Set	—	U32RT (4)	U32RT (4)	U32RT (4)	C32R (1)	L32RT (1)
						Nest Indentor	A32D (2) Y34PR	U32D1 (2) Y34PR	U32D1 (2) Y34PR	U32D1 (2) Y34PR	C32D (2) Y48PR	—
YFS34CPL	500 kcmil	1-11/32	15-7/8	2-3/8	20	Brown Die Set	—	U34RT (4)	U34RT (4) P34RT (4)	U34RT (4)	C34R (2)	L34RT (2)
						Nest Indentor	A34D (2) Y34PR	U34D1 (2) Y34PR	U34D1 (2) Y34PR	U34D1 (2) Y34PR	C34D (2) Y48PR	—

Limiters, Types YFSR, YFSP

For Use with Limiter Assembly

The Limiter serves the double function of a fuse and a coupler. The fusible element is an integral part of the coupler and is closely and carefully sized to insure excellent performance. Fusing characteristics of the Limiter are shown in technical section. For proper HYPRESS™ installation, see table below.

For conductor sizes not listed call customer service.

To specify a fast acting limiter in any configuration insert an "F" before the conductor number (e.g., YFSF34CR specifies a 1/2 thick limiter section).

*Paper Insulated Cable - Oil Tight Cable Sockets.

- ① Y35P3 Indentor Adaptor required for Y34PR Indentor
- ② Catalog number PUADP1 Adaptor is required to use "U" type dies in the 46 series tools
- ③ Catalog number PT6515 Adaptor is required to use "U" type dies in the 45 series tools

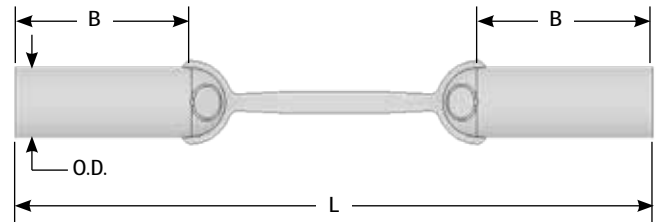

For use on Rubber Insulated Cable	For use on Paper Insulated Cable*	Cable Size	Dimensions in Inches			Installation Tooling (# Crimps)							
			B	L	O.D.	Die Information		Hydraulic					
						Die Index	Type ①	Y34A	35, 750 Series	46 Series ②	45 Series ③	Y48B	60 Series
YFSR28	YFSP28	4/0 Str.	1-3/4 in	6-3/8	11/16	15	Purple Die Set	—	U28RT (2)	U28RT (2)	U28RT (2)	C28R (2)	L28RT (1)
							Nest Indentor	A28D (1) Y34PR	U28D1 (1) Y34PR	U28D1 (1) Y34PR	U28D1 (1) Y34PR	C28D (1) Y48PR	—
YFSR29	YFSP29	250 kcmil	1-7/8 in	6-3/8	3/4	16	Yellow Die Set	—	U29RT (2)	U29RT (2)	U29RT (2)	C29R (2)	L29RT (1)
							Nest Indentor	A29D (2) Y34PR	U29D1 (2) Y34PR	U29D1 (2) Y34PR	U29D1 (2) Y34PR	C29D (1) Y48PR	—
YFSR30	YFSP30	300 kcmil	2 in	6-3/4	13/16	17	White Die Set	—	U30RT (4)	U30RT (4)	U30RT (4)	C30R (1)	L30RT (1)
							Nest Indentor	A30D (2) Y34PR	U30D1 (2) Y34PR	U30D1 (2) Y34PR	U30D1 (2) Y34PR	C30D (2) Y48PR	—
YFSR31	YFSP31	350 kcmil	2 in	6-3/4	7/8	18	Red Die Set	—	U31RT (4)	U31RT (4)	U31RT (4)	C31R (1)	L31RT (1)
							Nest Indentor	A31D (2) Y34PR	U31D1 (2) Y34PR	U31D1 (2) Y34PR	U31D1 (2) Y34PR	C31D (1) Y48PR	—
YFSR32	YFSP32	400 kcmil	2-1/8 in	7	31/32	19	Blue Die Set	—	U32RT (4)	U32RT (4)	U32RT (4)	C32R (1)	L32RT (1)
							Nest Indentor	A32D (2) Y34PR	U32D1 (2) Y34PR	U32D1 (2) Y34PR	U32D1 (2) Y34PR	C32D (2) Y48PR	—
YFSR34	YFSP34	500 kcmil	2-7/8 in	8-3/4	1-1/16	20	Brown Die Set	—	U34RT (4)	U34RT (4) P34RT (4)	U34RT (4)	C34R (2)	L34RT (2)
							Nest Indentor	A34D (2) Y34PR	U34D1 (2) Y34PR	U34D1 (2) Y34PR	U34D1 (2) Y34PR	C34D (2) Y48PR	—

Long Limiter, Type YFSP-L For Use with Long Limiter Assembly

The Long Limiter serves the same purpose as the Limiter shown above but has extra long oil tight cable sockets which may be preferred by some for use on paper insulated cables. Similarly designed to clear on overloads that will damage the insulation of the cable. Fusing characteristics of the Long Limiter are shown in technical section. For HYPRESS™ installation, see table below.

For conductor sizes not listed call customer service.

To specify a fast acting limiter in any configuration insert an "F" before the conductor number (e.g., YFSF34CR specifies a 1/2 thick limiter section).

- ① Y35P3 Indentor Adaptor required for Y34PR Indentor
- ② Catalog number PUADP1 Adaptor is required to use "U" type dies in the 46 series tools
- ③ Catalog number PT6515 Adaptor is required to use "U" type dies in the 45 series tools

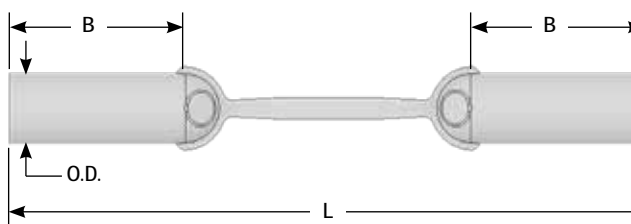

Catalog Number	Cable Size	Dimensions in Inches			Installation Tooling (# Crimps)							
		B	L	O.D.	Die Information		Hydraulic					
					Die Index	Type ①	Y34A	35, 750 Series	46 Series ②	45 Series ③	Y48B	60 Series
YFSP28L	4/0 Str.	2-15/16 in	8-3/4	11/16	15	Purple Die Set	—	U28RT (2)	U28RT (2)	U28RT (2)	C28R (2)	L28RT (1)
						Nest Indentor	A28D (1) Y34PR	U28D1 (1) Y34PR	U28D1 (1) Y34PR	U28D1 (1) Y34PR	C28D (1) Y48PR	—
YFSP29L	250 kcmil	3-1/16 in	8-3/4	3/4	16	Yellow Die Set	—	U29RT (2)	U29RT (2)	U29RT (2)	C29R (2)	L29RT (1)
						Nest Indentor	A29D (2) Y34PR	U29D1 (2) Y34PR	U29D1 (2) Y34PR	U29D1 (2) Y34PR	C29D (1) Y48PR	—
YFSP30L	300 kcmil	3-3/8 in	9-1/2	13/16	17	White Die Set	—	U30RT (4)	U30RT (4)	U30RT (4)	C30R (1)	L30RT (1)
						Nest Indentor	A30D (2) Y34PR	U30D1 (2) Y34PR	U30D1 (2) Y34PR	U30D1 (2) Y34PR	C30D (2) Y48PR	—
YFSP31L	350 kcmil	3-3/8 in	9-1/2	7/8	18	Red Die Set	—	U31RT (4)	U31RT (4)	U31RT (4)	C31R (1)	L31RT (1)
						Nest Indentor	A31D (2) Y34PR	U31D1 (2) Y34PR	U31D1 (2) Y34PR	U31D1 (2) Y34PR	C31D (1) Y48PR	—
YFSP32L	400 kcmil	3-3/8 in	9-1/2	31/32	19	Blue Die Set	—	U32RT (4)	U32RT (4)	U32RT (4)	C32R (1)	L32RT (1)
						Nest Indentor	A32D (2) Y34PR	U32D1 (2) Y34PR	U32D1 (2) Y34PR	U32D1 (2) Y34PR	C32D (2) Y48PR	—
YFSP34L	500 kcmil	4-3/16 in	11-3/8	1-1/16	20	Brown Die Set	—	U34RT (4)	U34RT (4) P34RT (4)	U34RT (4)	C34R (2)	L34RT (2)
						Nest Indentor	A34D (2) Y34PR	U34D1 (2) Y34PR	U34D1 (2) Y34PR	U34D1 (2) Y34PR	C34D (2) Y48PR	—

Limiter Lug Assembly, Types YFA-CR, YFA-CP
With Ceramic Shell and Rubber Sleeve

The Limiter Lug combines the functions of terminal and fuse. The fusible element is an integral part of the connector and is so designed that it will clear overloads which are great enough to cause damage to the cable insulation. Unlike an ordinary fuse, however, it will not clear on minor overloads of short duration. Fusing characteristics of the Limiter Lugs are shown in the technical section. Component parts shown in the table below may be purchased separately. For proper HYPRESS™ installation, see table below.

For conductor sizes not listed call customer service.

*Paper Insulated Cable - Oil Tight Cable Sockets.

- ① Y35P3 Indentor Adaptor required for Y34PR Indentor
- ② Catalog number PUADP1 Adaptor is required to use "U" type dies in the 46 series tools
- ③ Catalog number PT6515 Adaptor is required to use "U" type dies in the 45 series tools

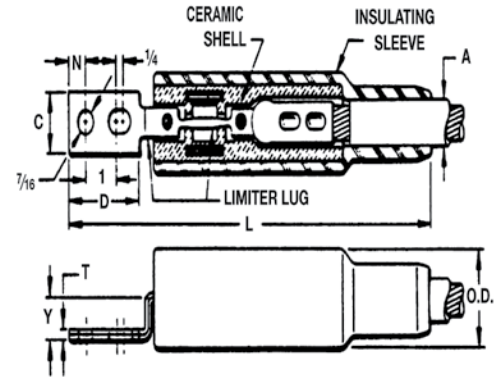

For Use On		Cable Size	Dimensions in Inches								Installation Tooling (# Crimps)							
Rubber Insulated Cable	Paper Insulated Cable*		(Max. Cable Dia. over Insul.) A	C	D	L	N	T	Y	O.D.	Die Information		Hydraulic					
Catalog Number											Die Index	Type ①	Y34A	35, 750 Series	46 Series ②	45 Series ③	Y48B	60 Series
YFA28CR2	YFA28CP2	4/0 Str.	1.00	1.00	2.19	11.56	0.44	0.14	0.84	2.00	15	Purple Die Set	—	U28RT (2)	U28RT (2)	U28RT (2)	C28R (2)	L28RT (1)
												Nest Indentor	A28D (1) Y34PR	U28D1 (1) Y34PR	U28D1 (1) Y34PR	U28D1 (1) Y34PR	C28D (1) Y48PR	—
YFA29CR2	YFA29CP2	250 kcmil	1.00	1.13	2.19	11.56	0.44	0.16	0.84	2.00	16	Yellow Die Set	—	U29RT (2)	U29RT (2)	U29RT (2)	C29R (2)	L29RT (1)
												Nest Indentor	A29D (2) Y34PR	U29D1 (2) Y34PR	U29D1 (2) Y34PR	U29D1 (2) Y34PR	C29D (1) Y48PR	—
YFA30CR2	YFA30CP2	300 kcmil	1.22	1.19	2.31	13.19	0.50	0.16	1.00	2.38	17	White Die Set	—	U30RT (4)	U30RT (4)	U30RT (4)	C30R (1)	L30RT (1)
												Nest Indentor	A30D (2) Y34PR	U30D1 (2) Y34PR	U30D1 (2) Y34PR	U30D1 (2) Y34PR	C30D (2) Y48PR	—
YFA31CR2	YFA31CP2	350 kcmil	1.22	1.31	2.31	13.19	0.50	0.19	1.00	2.38	18	Red Die Set	—	U31RT (4)	U31RT (4)	U31RT (4)	C31R (1)	L31RT (1)
												Nest Indentor	A31D (2) Y34PR	U31D1 (2) Y34PR	U31D1 (2) Y34PR	U31D1 (2) Y34PR	C31D (1) Y48PR	—
YFA32CR2	—	400 kcmil	1.22	1.44	2.31	13.19	0.50	0.19	1.00	2.38	19	Blue Die Set	—	U32RT (4)	U32RT (4)	U32RT (4)	C32R (1)	L32RT (1)
												Nest Indentor	A32D (2) Y34PR	U32D1 (2) Y34PR	U32D1 (2) Y34PR	U32D1 (2) Y34PR	C32D (2) Y48PR	—
YFA34CR2	YFA34CP2	500 kcmil	1.34	1.50	2.75	13.63	0.50	0.22	1.00	2.38	20	Brown Die Set	—	U34RT (4)	U34RT (4) P34RT (4)	U34RT (4)	C34R (2)	L34RT (2)
												Nest Indentor	A34D (2) Y34PR	U34D1 (2) Y34PR	U34D1 (2) Y34PR	U34D1 (2) Y34PR	C34D (2) Y48PR	—
YFA39CR2	YFA39CP2	750 kcmil	1.50	1.94	2.75	13.63	0.50	0.25	1.00	2.38	24	Black Die Set	—	U39RT (4)	U39RT (4) P39RT (4)	U39RT (4) S39RT (4)	C39R (2)	L39RT (2)
												Nest Indentor	—	—	P32D (2) P44PR	—	C39D (2) Y48PR	—

Long Limiter Lug Assembly, Type YFA-CPL With Ceramic Shell and Rubber Sleeve for Paper Lead Cables

A Limiter Lug similar to Type YFA-CR or YFACP. In this case, however, we supply an extra long cable socket which is sometimes preferred for use on paper insulated cable. The end seams are sealed to make sockets oil tight. Fusing characteristics of the Limiter Lugs are shown in the technical section. For proper HYPRESS™ installation, see table below.

For conductor sizes not listed call customer service.

- ① Y35P3 Indentor Adaptor required for Y34PR Indentor
- ② Catalog number PUADP1 Adaptor is required to use "U" type dies in the 46 series tools
- ③ Catalog number PT6515 Adaptor is required to use "U" type dies in the 45 series tools

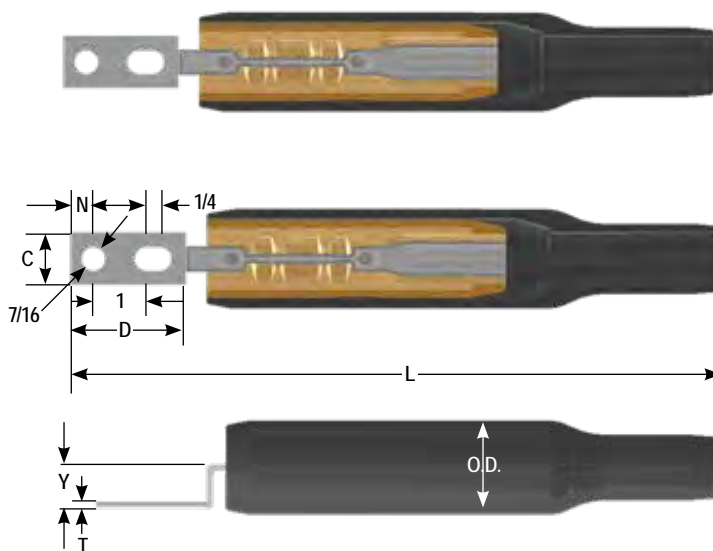

Catalog Number	Cable Size	(Max. Cable Dia. over Insul.) A	Dimensions in Inches							Installation Tooling (# Crimps)							
			C	D	L	N	T	Y	O.D.	Die Information		Hydraulic					
										Die Index	Type ①	Y34A	35, 750 Series	46 Series ②	45 Series ③	Y48B	60 Series
YFA28CPL2	4/0 Str.	1.00	1.00	2.19	11.56	0.44	0.14	0.84	2.00	15	Purple Die Set	—	U28RT (2)	U28RT (2)	U28RT (2)	C28R (2)	L28RT (1)
											Nest Indentor	A28D (1) Y34PR	U28D1 (1) Y34PR	U28D1 (1) Y34PR	U28D1 (1) Y34PR	C28D (1) Y48PR	—
YFA29CPL2	250 kcmil	1.00	1.09	2.19	11.56	0.44	0.16	0.84	1.75	16	Yellow Die Set	—	U29RT (2)	U29RT (2)	U29RT (2)	C29R (2)	L29RT (1)
											Nest Indentor	A29D (2) Y34PR	U29D1 (2) Y34PR	U29D1 (2) Y34PR	U29D1 (2) Y34PR	C29D (1) Y48PR	—
YFA30CPL2	300 kcmil	1.22	1.19	2.31	13.19	0.50	0.16	1.00	2.38	17	White Die Set	—	U30RT (4)	U30RT (4)	U30RT (4)	C30R (1)	L30RT (1)
											Nest Indentor	A30D (2) Y34PR	U30D1 (2) Y34PR	U30D1 (2) Y34PR	U30D1 (2) Y34PR	C30D (2) Y48PR	—
YFA31CPL2	350 kcmil	1.22	1.28	2.31	13.19	0.50	0.19	1.00	0.88	18	Red Die Set	—	U31RT (4)	U31RT (4)	U31RT (4)	C31R (1)	L31RT (1)
											Nest Indentor	A31D (2) Y34PR	U31D1 (2) Y34PR	U31D1 (2) Y34PR	U31D1 (2) Y34PR	C31D (1) Y48PR	—
YFA32CPL2	400 kcmil	1.22	1.44	2.31	13.19	0.50	0.19	1.00	2.38	19	Blue Die Set	—	U32RT (4)	U32RT (4)	U32RT (4)	C32R (1)	L32RT (1)
											Nest Indentor	A32D (2) Y34PR	U32D1 (2) Y34PR	U32D1 (2) Y34PR	U32D1 (2) Y34PR	C32D (2) Y48PR	—
YFA34CPL2	500 kcmil	1.34	1.50	2.75	13.63	0.50	0.22	1.00	1.06	20	Brown Die Set	—	U34RT (4)	U34RT (4) P34RT (4)	U34RT (4)	C34R (2)	L34RT (2)
											Nest Indentor	A34D (2) Y34PR	U34D1 (2) Y34PR	U34D1 (2) Y34PR	U34D1 (2) Y34PR	C34D (2) Y48PR	—
YFA39CPL2	750 kcmil	1.50	1.94	2.75	13.63	0.50	0.25	1.00	2.38	24	Black Die Set	—	U39RT (4)	U39RT (4) P39RT (4)	U39RT (4) S39RT (4)	C39R (2)	L39RT (2)
											Nest Indentor	—	—	P32D (2) P44PR	—	C39D (2) Y48PR	—

Limiter Lug, Types YFAR, YFAP
For Use with Limiter Lug Assembly

The Limiter Lug incorporates an accurately determined fusible section as an integral part with its terminal end. The fusible section is so selected that it will prevent the cable from roasting or damage from a short circuit, although it will not clear on minor overloads of short duration not harmful to cable insulation. For proper HYPRESS™ installation, see table below.

For conductor sizes not listed call customer service.

*Paper Insulated Cable - Oil Tight Cable Sockets.

- ① Y35P3 Indentor Adaptor required for Y34PR Indentor
- ② Catalog number PUADP1 Adaptor is required to use "U" type dies in the 46 series tools
- ③ Catalog number PT6515 Adaptor is required to use "U" type dies in the 45 series tools

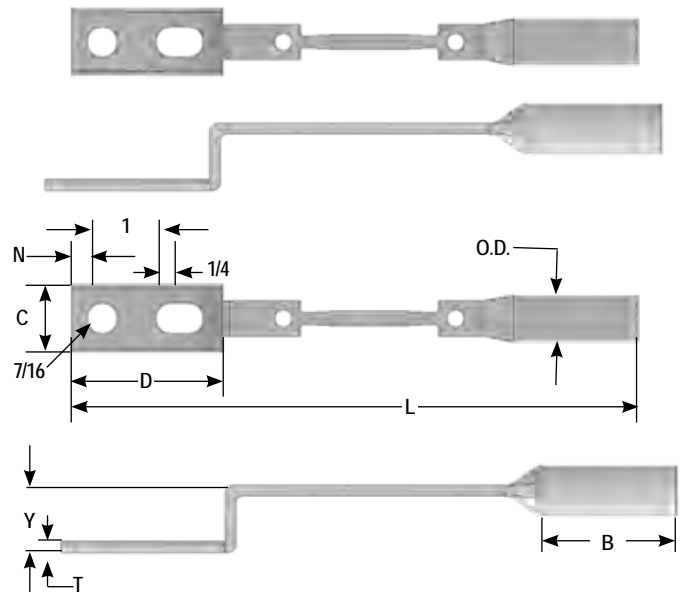

For Use On		Cable Size	Dimensions in Inches							Installation Tooling (# Crimps)								
Rubber Insulated Cable	Paper Insulated Cable*		B	C	D	L	N	T	Y	O.D.	Die Information		Hydraulic					
Catalog Number											Die Index	Type ①	Y34A	35, 750 Series	46 Series ②	45 Series ③	Y48B	60 Series
YFAR282	YFAP282	4/0 Str.	1.81	1.00	2.19	8.22	0.44	0.14	0.89	0.70	15	Purple Die Set	—	U28RT (2)	U28RT (2)	U28RT (2)	C28R (2)	L28RT (1)
												Nest Indentor	A28D (1) Y34PR	U28D1 (1) Y34PR	U28D1 (1) Y34PR	U28D1 (1) Y34PR	C28D (1) Y48PR	—
YFAR292	YFAP292	250 kcmil	1.81	1.09	2.19	8.22	0.44	0.16	0.91	0.76	16	Yellow Die Set	—	U29RT (2)	U29RT (2)	U29RT (2)	C29R (2)	L29RT (1)
												Nest Indentor	A29D (2) Y34PR	U29D1 (2) Y34PR	U29D1 (2) Y34PR	U29D1 (2) Y34PR	C29D (1) Y48PR	—
YFAR302	YFAP302	300 kcmil	1.94	1.19	2.31	8.88	0.50	0.16	1.07	0.83	17	White Die Set	—	U30RT (4)	U30RT (4)	U30RT (4)	C30R (1)	L30RT (1)
												Nest Indentor	A30D (2) Y34PR	U30D1 (2) Y34PR	U30D1 (2) Y34PR	U30D1 (2) Y34PR	C30D (2) Y48PR	—
YFAR312	YFAP312	350 kcmil	1.94	1.28	2.31	8.88	0.50	0.18	1.08	0.89	18	Red Die Set	—	U31RT (4)	U31RT (4)	U31RT (4)	C31R (1)	L31RT (1)
												Nest Indentor	A31D (2) Y34PR	U31D1 (2) Y34PR	U31D1 (2) Y34PR	U31D1 (2) Y34PR	C31D (1) Y48PR	—
YFAR322	YFAP322	400 kcmil	2.06	1.38	2.31	9.12	0.50	0.19	1.10	0.97	19	Blue Die Set	—	U32RT (4)	U32RT (4)	U32RT (4)	C32R (1)	L32RT (1)
												Nest Indentor	A32D (2) Y34PR	U32D1 (2) Y34PR	U32D1 (2) Y34PR	U32D1 (2) Y34PR	C32D (2) Y48PR	—
YFAR342	YFAP342	500 kcmil	2.44	1.54	2.75	10.00	0.50	0.23	1.11	0.97	20	Brown Die Set	—	U34RT (4)	U34RT (4) P34RT (4)	U34RT (4)	C34R (2)	L34RT (2)
												Nest Indentor	A34D (2) Y34PR	U34D1 (2) Y34PR	U34D1 (2) Y34PR	U34D1 (2) Y34PR	C34D (2) Y48PR	—
YFAR392	YFAP392	750 kcmil	2.44	1.91	2.75	10.00	0.50	0.26	1.14	1.34	24	Black Die Set	—	U39RT (4)	U39RT (4) P39RT (4)	U39RT (4) S39RT (4)	C39R (2)	L39RT (2)
												Nest Indentor	—	—	P32D (2) P44PR	—	C39D (2) Y48PR	—

Long Limiter Lug, Type YFAP-L For Use with Limited Lug Assembly

Similar to Limiter Lug Types YFAR and YFAP, except that this type provides a long oil tight cable socket, preferred by some users of paper-insulated cables. Fusing characteristics shown in technical section. For HYPRESS™ installation, see table below.

For conductor sizes not listed call customer service.

- ① Y35P3 Indentor Adaptor required for Y34PR Indentor
- ② Catalog number PUADP1 Adaptor is required to use "U" type dies in the 46 series tools
- ③ Catalog number PT6515 Adaptor is required to use "U" type dies in the 45 series tools

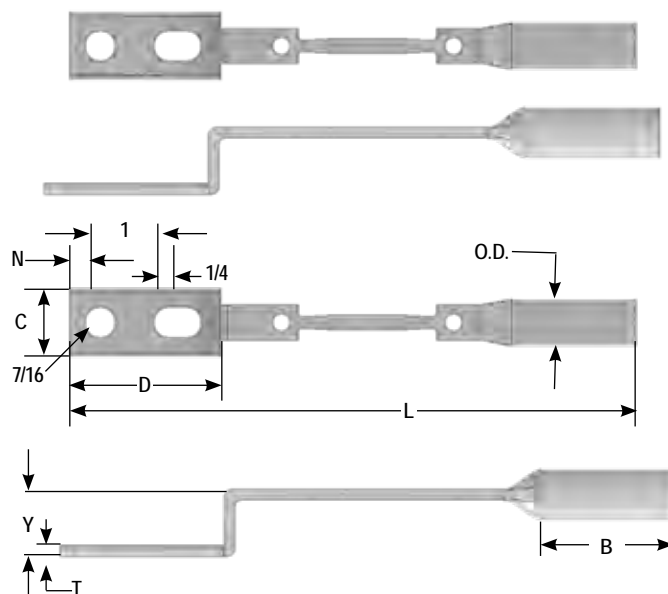

Catalog Number	Cable Size	Dimensions in Inches								Installation Tooling (# Crimps)							
		B	C	D	L	N	T	Y	O.D.	Die Information		Hydraulic					
										Die Index	Type ①	Y34A	35, 750 Series	46 Series ②	45 Series ③	Y48B	60 Series
YFAP28L2	4/0 Str.	3.50	1.00	2.19	10.44	0.44	0.14	0.89	0.69	15	Purple Die Set	—	U28RT (2)	U28RT (2)	U28RT (2)	C28R (2)	L28RT (1)
											Nest Indentor	A28D (1) Y34PR	U28D1 (1) Y34PR	U28D1 (1) Y34PR	U28D1 (1) Y34PR	C28D (1) Y48PR	—
YFAP29L2	250 kcmil	3.56	1.12	2.18	10.44	0.44	0.16	0.89	0.75	16	Yellow Die Set	—	U29RT (2)	U29RT (2)	U29RT (2)	C29R (2)	L29RT (1)
											Nest Indentor	A29D (2) Y34PR	U29D1 (2) Y34PR	U29D1 (2) Y34PR	U29D1 (2) Y34PR	C29D (1) Y48PR	—
YFAP30L2	300 kcmil	3.63	1.18	2.31	11.19	0.50	0.16	1.10	0.76	17	White Die Set	—	U30RT (4)	U30RT (4)	U30RT (4)	C30R (1)	L30RT (1)
											Nest Indentor	A30D (2) Y34PR	U30D1 (2) Y34PR	U30D1 (2) Y34PR	U30D1 (2) Y34PR	C30D (2) Y48PR	—
YFAP31L2	350 kcmil	3.63	1.38	2.31	11.38	0.50	0.18	1.08	0.82	18	Red Die Set	—	U31RT (4)	U31RT (4)	U31RT (4)	C31R (1)	L31RT (1)
											Nest Indentor	A31D (2) Y34PR	U31D1 (2) Y34PR	U31D1 (2) Y34PR	U31D1 (2) Y34PR	C31D (1) Y48PR	—
YFAP32L2	400 kcmil	3.75	1.38	2.31	11.50	0.50	0.19	1.10	0.89	19	Blue Die Set	—	U32RT (4)	U32RT (4)	U32RT (4)	C32R (1)	L32RT (1)
											Nest Indentor	A32D (2) Y34PR	U32D1 (2) Y34PR	U32D1 (2) Y34PR	U32D1 (2) Y34PR	C32D (2) Y48PR	—
YFAP34L2	500 kcmil	4.13	1.54	2.75	12.25	0.50	0.23	1.11	0.98	20	Brown Die Set	—	U34RT (4)	U34RT (4) P34RT (4)	U34RT (4)	C34R (2)	L34RT (2)
											Nest Indentor	A34D (2) Y34PR	U34D1 (2) Y34PR	U34D1 (2) Y34PR	U34D1 (2) Y34PR	C34D (2) Y48PR	—
YFAP39L2	750 kcmil	4.13	1.91	2.75	12.31	0.50	0.27	1.14	1.20	24	Black Die Set	—	U39RT (4)	U39RT (4) P39RT (4)	U39RT (4) S39RT (4)	C39R (2)	L39RT (2)
											Nest Indentor	—	—	P32D (2) P44PR	—	C39D (2) Y48PR	—

MOLIMITER™ Assembly, Types YFM-CR, YFM-CP
With Ceramic Shell and Rubber Sleeve for Insulated Cables

The MOLIMITER™ is used for fusing underground cables at junction points. The unit is designed for use with the BURNDY® MOLE™ and provides Limiter protection for cables, which terminate at the MOLE™. The cable end is installed in the MOLIMITER™ cable socket (see Installation Information in table below) and then the MOLE™ end is installed in the MOLE™ outlet Socket and Nut assembly. Any MOLIMITER which has burned clear may be quickly replaced. For time current characteristics see the technical section.

For conductor sizes not listed call customer service.

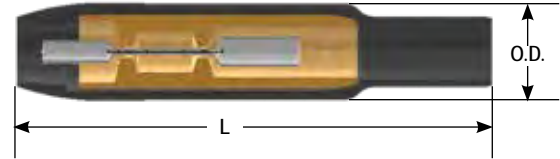

*Paper Insulated Cable - Oil Tight Cable Sockets.

- ① Y35P3 Indentor Adaptor required for Y34PR Indentor
- ② Catalog number PUADP1 Adaptor is required to use "U" type dies in the 46 series tools
- ③ Catalog number PT6515 Adaptor is required to use "U" type dies in the 45 series tools

For Use On		Cable Size	Dimensions in Inches			For Connection to MOLE™ Use		MOLE™ Outlet Size	Installation Tooling (# Crimps)							
Rubber Insulated Cable	Paper Insulated Cable*		(Max. Cable Dia. Over Insul.) A	L	O.D.	Socket and Nut Assembly	Z Cone		Die Information		Hydraulic					
Catalog Number									Die Index	Type ①	Y34A	35, 750 Series	46 Series ②	45 Series ③	Y48B	60 Series
YFM28CR	YFM28CP	4/0 Str.	1.34	11.69	2.38	Z28NR	Z2828	A	15	Purple Die Set	—	U28RT (2)	U28RT (2)	U28RT (2)	C28R (2)	L28RT (1)
										Nest Indentor	A28D (1) Y34PR	U28D1 (1) Y34PR	U28D1 (1) Y34PR	U28D1 (1) Y34PR	C28D (1) Y48PR	—
YFM29CR	YFM29CP	250 kcmil	1.34	11.69	2.38	Z29NR	Z2929	A	16	Yellow Die Set	—	U29RT (2)	U29RT (2)	U29RT (2)	C29R (2)	L29RT (1)
										Nest Indentor	A29D (2) Y34PR	U29D1 (2) Y34PR	U29D1 (2) Y34PR	U29D1 (2) Y34PR	C29D (1) Y48PR	—
YFM30CR	YFM30CP	300 kcmil	1.34	11.69	2.38	Z30NR	Z3030	A	17	White Die Set	—	U30RT (4)	U30RT (4)	U30RT (4)	C30R (1)	L30RT (1)
										Nest Indentor	A30D (2) Y34PR	U30D1 (2) Y34PR	U30D1 (2) Y34PR	U30D1 (2) Y34PR	C30D (2) Y48PR	—
YFM31CR	YFM31CP	350 kcmil	1.34	11.69	2.38	Z31NR	Z3131	A	18	Red Die Set	—	U31RT (4)	U31RT (4)	U31RT (4)	C31R (1)	L31RT (1)
										Nest Indentor	A31D (2) Y34PR	U31D1 (2) Y34PR	U31D1 (2) Y34PR	U31D1 (2) Y34PR	C31D (1) Y48PR	—
YFM32CR	YFM32CP	400 kcmil	1.34	11.69	2.38	Z32NR	Z3232	A	19	Blue Die Set	—	U32RT (4)	U32RT (4)	U32RT (4)	C32R (1)	L32RT (1)
										Nest Indentor	A32D (2) Y34PR	U32D1 (2) Y34PR	U32D1 (2) Y34PR	U32D1 (2) Y34PR	C32D (2) Y48PR	—
YFM34CR	YFM34CP	500 kcmil	1.34	11.69	2.38	Z34NR	Z3434	A	20	Brown Die Set	—	U34RT (4)	U34RT (4) P34RT (4)	U34RT (4)	C34R (2)	L34RT (2)
										Nest Indentor	A34D (2) Y34PR	U34D1 (2) Y34PR	U34D1 (2) Y34PR	U34D1 (2) Y34PR	C34D (2) Y48PR	—

Long MOLIMITER™ Assembly, Type YFM-CPL With Ceramic Shell and Rubber Sleeve for Paper Lead Cables

The Long MOLIMITER™ differs from the standard MOLIMITER™ only in its extra long cable socket. This socket, with the end seam sealed oil tight, is preferred by some for use on paper insulated cables. Time-current characteristics are shown in the technical section. For proper HYPRESS™ installation, see table below.

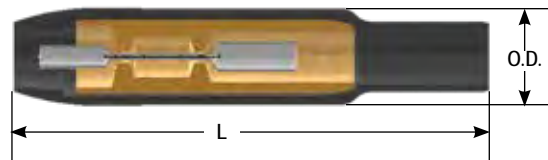

For conductor sizes not listed call customer service.

- ① Y35P3 Indentor Adaptor required for Y34PR Indentor
- ② Catalog number PUADP1 Adaptor is required to use "U" type dies in the 46 series tools
- ③ Catalog number PT6515 Adaptor is required to use "U" type dies in the 45 series tools

Catalog Number	Cable Size	Dimensions in Inches			For Connection to MOLE™ Use		MOLE™ Outlet Size	Installation Tooling (# Crimps)							
		(Max. Cable Dia. Over Insul.) A	L	O.D.	Socket & Nut Assembly	Z Cone		Die Information		Hydraulic					
								Die Index	Type ①	Y34A	35, 750 Series	46 Series ②	45 Series ③	Y48B	60 Series
YFM28CPL	4/0 Str.	1.34	11.69	2.38	Z28NR	Z2828	A	15	Purple Die Set	—	U28RT (2)	U28RT (2)	U28RT (2)	C28R (2)	L28RT (1)
									Nest Indentor	A28D (1) Y34PR	U28D1 (1) Y34PR	U28D1 (1) Y34PR	U28D1 (1) Y34PR	C28D (1) Y48PR	—
YFM29CPL	250 kcmil	1.34	11.69	2.38	Z29NR	Z2929	A	16	Yellow Die Set	—	U29RT (2)	U29RT (2)	U29RT (2)	C29R (2)	L29RT (1)
									Nest Indentor	A29D (2) Y34PR	U29D1 (2) Y34PR	U29D1 (2) Y34PR	U29D1 (2) Y34PR	C29D (1) Y48PR	—
YFM30CPL	300 kcmil	1.34	11.69	2.38	Z30NR	Z3030	A	17	White Die Set	—	U30RT (4)	U30RT (4)	U30RT (4)	C30R (1)	L30RT (1)
									Nest Indentor	A30D (2) Y34PR	U30D1 (2) Y34PR	U30D1 (2) Y34PR	U30D1 (2) Y34PR	C30D (2) Y48PR	—
YFM31CPL	350 kcmil	1.34	11.69	2.38	Z32NR	Z3132	A	18	Red Die Set	—	U31RT (4)	U31RT (4)	U31RT (4)	C31R (1)	L31RT (1)
									Nest Indentor	A31D (2) Y34PR	U31D1 (2) Y34PR	U31D1 (2) Y34PR	U31D1 (2) Y34PR	C31D (1) Y48PR	—
YFM32CPL	400 kcmil	1.34	11.69	2.38	Z32NR	Z3232	A	19	Blue Die Set	—	U32RT (4)	U32RT (4)	U32RT (4)	C32R (1)	L32RT (1)
									Nest Indentor	A32D (2) Y34PR	U32D1 (2) Y34PR	U32D1 (2) Y34PR	U32D1 (2) Y34PR	C32D (2) Y48PR	—
YFM34CPL	500 kcmil	1.34	11.69	2.38	Z34NR	Z3434	A	20	Brown Die Set	—	U34RT (4)	U34RT (4) P34RT (4)	U34RT (4)	C34R (2)	L34RT (2)
									Nest Indentor	A34D (2) Y34PR	U34D1 (2) Y34PR	U34D1 (2) Y34PR	U34D1 (2) Y34PR	C34D (2) Y48PR	—

MOLIMITER™ Limiter, Types YFMR, YFMP
For Use with Long MOLIMITER™ Assembly

The MOLIMITER™ combines an accurately determined fusible section with both a MOLE™ Socket end and a cable socket. Designed to clear on overloads that would injure the cable insulation, the MOLIMITER™ may be easily and quickly replaced. For time current characteristics of MOLIMITER see the technical section. For proper HYPRESS™ installation, see table below.

For conductor sizes not listed call customer service.

*Paper Insulated Cable - Oil Tight Cable Sockets.

- ① Y35P3 Indentor Adaptor required for Y34PR Indentor
- ② Catalog number PUADP1 Adaptor is required to use "U" type dies in the 46 series tools
- ③ Catalog number PT6515 Adaptor is required to use "U" type dies in the 45 series tools

NOTE: To specify a fast acting limiter in any configuration insert an "F" before the conductor number e.g. YFSF34CR specifies a 1/2 thick limiter section.

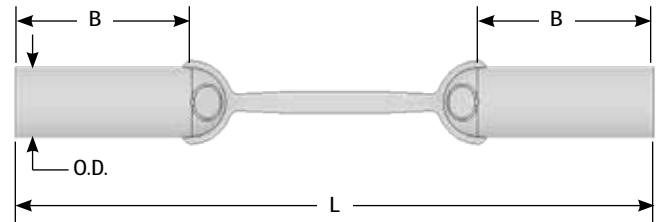

For Use On		Cable Size A	Dimensions in Inches			For Connection to MOLE™ Use		MOLE™ Outlet Size	Installation Tooling (# Crimps)							
Rubber Insulated Cable	Paper Insulated Cable*		B	L	O.D.	Socket and Nut Assembly	Z Cone		Die Information		Hydraulic					
Catalog Number									Die Index	Type ①	Y34A	35, 750 Series	46 Series ②	45 Series ③	Y48B	60 Series
YFMR28	YFMP28	4/0 Str.	1.86	6.28	0.83	Z28NR	Z2828	A	15	Purple Die Set	—	U28RT (2)	U28RT (2)	U28RT (2)	C28R (2)	L28RT (1)
										Nest Indentor	A28D (1) Y34PR	U28D1 (1) Y34PR	U28D1 (1) Y34PR	U28D1 (1) Y34PR	C28D (1) Y48PR	—
YFMR29	YFMP29	250 kcmil	1.88	6.19	0.84	Z29NR	Z2929	A	16	Yellow Die Set	—	U29RT (2)	U29RT (2)	U29RT (2)	C29R (2)	L29RT (1)
										Nest Indentor	A29D (2) Y34PR	U29D1 (2) Y34PR	U29D1 (2) Y34PR	U29D1 (2) Y34PR	C29D (1) Y48PR	—
YFMR30	YFMP30	300 kcmil	2.00	6.81	0.96	Z30NR	Z3030	A	17	White Die Set	—	U30RT (4)	U30RT (4)	U30RT (4)	C30R (1)	L30RT (1)
										Nest Indentor	A30D (2) Y34PR	U30D1 (2) Y34PR	U30D1 (2) Y34PR	U30D1 (2) Y34PR	C30D (2) Y48PR	—
YFMR31	YFMP31	350 kcmil	2.00	6.94	0.91	Z32NR	Z3132	A	18	Red Die Set	—	U31RT (4)	U31RT (4)	U31RT (4)	C31R (1)	L31RT (1)
										Nest Indentor	A31D (2) Y34PR	U31D1 (2) Y34PR	U31D1 (2) Y34PR	U31D1 (2) Y34PR	C31D (1) Y48PR	—
YFMR32	YFMP32	400 kcmil	2.14	7.27	0.97	Z32NR	Z3232	A	19	Blue Die Set	—	U32RT (4)	U32RT (4)	U32RT (4)	C32R (1)	L32RT (1)
										Nest Indentor	A32D (2) Y34PR	U32D1 (2) Y34PR	U32D1 (2) Y34PR	U32D1 (2) Y34PR	C32D (2) Y48PR	—
YFMR34	YFMP34	500 kcmil	2.75	8.26	1.13	Z34NR	Z3434	A	20	Brown Die Set	—	U34RT (4)	U34RT (4) P34RT (4)	U34RT (4)	C34R (2)	L34RT (2)
										Nest Indentor	A34D (2) Y34PR	U34D1 (2) Y34PR	U34D1 (2) Y34PR	U34D1 (2) Y34PR	C34D (2) Y48PR	—

Long MOLIMITER™ Limiter, Type YFMP-L For Use with Long MOLIMITER™ Assembly

Similar to Type YFMR and YFMP except for a long oil tight cable socket preferred by some users of paper-insulated cable. Fusing characteristics shown in the technical sections. For proper HYPRESS™ installation, see table below

For conductor sizes not listed call customer service.

To specify a fast acting limiter in any configuration insert an "F" before the conductor number (e.g., YFSF34CR specifies a 1/2 thick limiter section).

- ① Y35P3 Indentor Adaptor required for Y34PR Indentor
- ② Catalog number PUADP1 Adaptor is required to use "U" type dies in the 46 series tools
- ③ Catalog number PT6515 Adaptor is required to use "U" type dies in the 45 series tools

NOTE: To specify a fast acting limiter in any configuration insert an "F" before the conductor number e.g. YFSF34CR specifies a 1/2 thick limiter section.

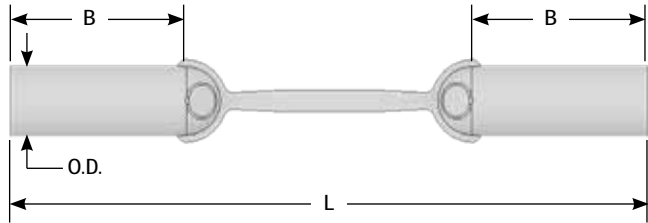

Catalog No.	Cable Size	Dimensions in Inches			For Connection to MOLE™ Use		MOLE™ Outlet Size	Installation Tooling (# Crimps)							
		B	L	O.D.	Socket & Nut Assembly	Z Cone		Die Information		Hydraulic					
								Die Index	Type ①	Y34A	35, 750 Series	46 Series ②	45 Series ③	Y48B	60 Series
YFMP28L	4/0 Str.	3.06	7.25	0.69	Z28NR	Z2828	A	15	Purple Die Set	—	U28RT (2)	U28RT (2)	U28RT (2)	C28R (2)	L28RT (1)
									Nest Indentor	A28D (1) Y34PR	U28D1 (1) Y34PR	U28D1 (1) Y34PR	U28D1 (1) Y34PR	C28D (1) Y48PR	—
YFMP29L	250 kcmil	3.56	7.88	0.75	Z29NR	Z2929	A	16	Yellow Die Set	—	U29RT (2)	U29RT (2)	U29RT (2)	C29R (2)	L29RT (1)
									Nest Indentor	A29D (2) Y34PR	U29D1 (2) Y34PR	U29D1 (2) Y34PR	U29D1 (2) Y34PR	C29D (1) Y48PR	—
YFMP30L	300 kcmil	3.67	8.48	0.81	Z30NR	Z3030	A	17	White Die Set	—	U30RT (4)	U30RT (4)	U30RT (4)	C30R (1)	L30RT (1)
									Nest Indentor	A30D (2) Y34PR	U30D1 (2) Y34PR	U30D1 (2) Y34PR	U30D1 (2) Y34PR	C30D (2) Y48PR	—
YFMP31L	350 kcmil	3.69	8.66	0.88	Z32NR	Z3132	A	18	Red Die Set	—	U31RT (4)	U31RT (4)	U31RT (4)	C31R (1)	L31RT (1)
									Nest Indentor	A31D (2) Y34PR	U31D1 (2) Y34PR	U31D1 (2) Y34PR	U31D1 (2) Y34PR	C31D (1) Y48PR	—
YFMP32L	400 kcmil	3.81	8.66	0.95	Z32NR	Z3232	A	19	Blue Die Set	—	U32RT (4)	U32RT (4)	U32RT (4)	C32R (1)	L32RT (1)
									Nest Indentor	A32D (2) Y34PR	U32D1 (2) Y34PR	U32D1 (2) Y34PR	U32D1 (2) Y34PR	C32D (2) Y48PR	—
YFMP34L	500 kcmil	4.13	9.44	1.06	Z34NR	Z3434	A	20	Brown Die Set	—	U34RT (4)	U34RT (4) P34RT (4)	U34RT (4)	C34R (2)	L34RT (2)
									Nest Indentor	A34D (2) Y34PR	U34D1 (2) Y34PR	U34D1 (2) Y34PR	U34D1 (2) Y34PR	C34D (2) Y48PR	—

Limiters Tap Assembly, Type VYFT
 For Insulated Cables

The Limiter Tap is suitable for making Limiter connections to a cable ring bus in a manhole or transformer vault. It can be installed on oil impregnated, paper insulated, or rubber insulated cable. Fusing characteristics of the Limiter are the same as Type YFA shown in the technical section. The rubber sleeve and insulating hood reduce taping to a minimum. Catalog Numbers shown include hoods. If no hood is required, eliminate one "C" from the Catalog Number. Replaceable Link Limiter Taps can be ordered. For proper HYPRESS™ installation, see table below.

Paper-Lead Cables: If a long cable socket is preferred for use on paper insulated cable add "L" to the catalog number (e.g., VYFT3428CCP becomes VYFT3428CCPL).

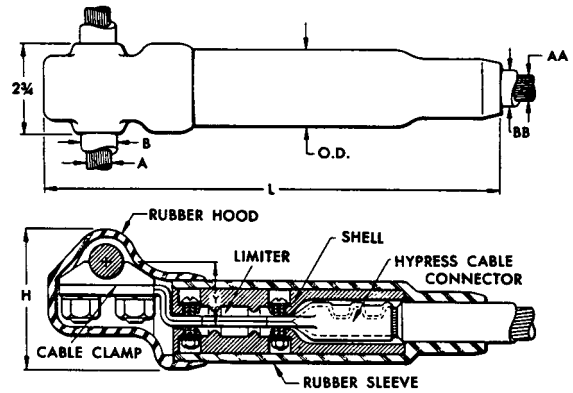

For Use on Rubber Insulated Cable Catalog No.	For Use on Paper Insulated Cable-Oil Tight Cable Socket Catalog No.	A Run	AA Tap	Dimensions in Inches						Installation Information	
				B Max. Cable Dia. Over Insul.	BB Max. Cable Dia. Over Insul.	H	L	Y	O.D.	HYPRESS™ & Indentor Die	No. of Indents
VYFT3428CCR	VYFT3428CCP	500 kcmil	4/0 Str.	1.09	1.00	4.00	12.19	1.75	1.94	Y34BH with Y34PR Nest Die	
VYFT3434CCR	VYFT3434CCP	500 kcmil	500 kcmil	1.09	1.34	4.00	14.19	1.75	2.38	No Nest Die Req'd.	2
VYFT3934CCR	VYFT3934CCP	750 kcmil	500 kcmil	1.31	1.34	4.00	14.19	1.75	2.38		2
VYFT4434CCR	VYFT4434CCP	1000 kcmil	500 kcmil	1.08	1.34	4.13	14.19	2.09	2.38		2

To specify a fast acting limiter in any configuration insert an "F" before the conductor number (e.g., YFSF34CR specifies a 1/2 thick limiter section).

Limiters Tee Tap, Type NYFT
 For Rubber or Paper Insulated Cables

The NYFT Limiter is similar to Type VYFT except the run conductor is clamped with a four bolt cap and the Limiter Tap is removable by means of a socket and nut assembly. The Limiter current characteristics are the same as Type YFA shown in the technical section.

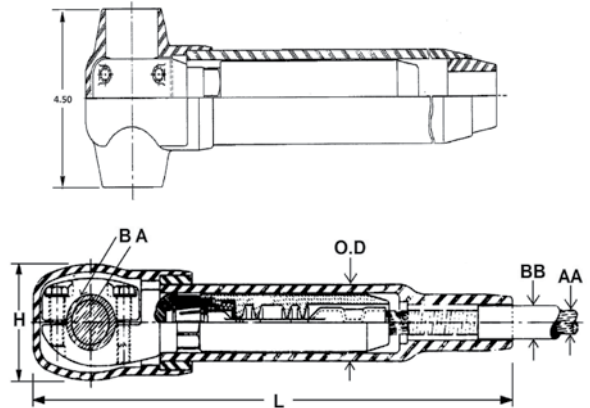

For Use on Rubber Insulated Cable Catalog No.	For Use on Paper Insulated Cable-Oil Tight Cable Socket Catalog No.	A Run	AA Tap	Dimensions in Inches						Installation Information	
				B Max. Cable Dia. Over Insul.	BB Max. Cable Dia. Over Insul.	H	L	O.D.	HYPRESS™ & Indentor Die	No. of Indents	
NYFT3434CCR	NYFT3434CCP	500 kcmil	500 kcmil	1.89	1.25	2.91	16.78	2.41	Y34BH with Y34PR Nest Die		2

Replaceable Link Limiter, Type LYS With Ceramic Shell and Rubber Sleeve for Insulated Cables

The Replaceable Link Limiter incorporates the functions of both fuse and coupler. For use with rubber and paper-insulated cable, it is designed to facilitate rapid and inexpensive replacement of Limiter Links upon clearing. It also permits, if desired, the use of a Link rated for a lower ampere capacity than supplied with our standard Limiter. For proper HYPRESS™ installation, see table below.

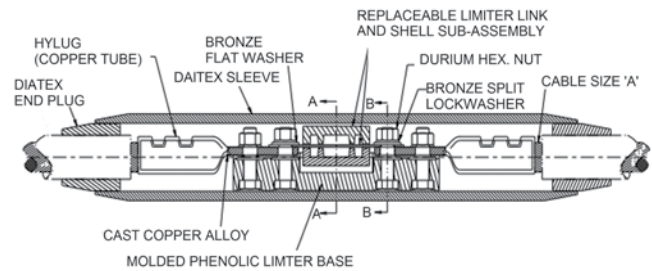

Catalog Number	Cable Size	** (Max. Cable Dia. Over Insul. Inches) A	Number of Indents in Cable Socket	* Link Supplied		Installation Information		
				Ampere Capacity	Catalog Number	No. of Indents	Installation Die Index Number	
LYS4CC	#4 Str.	0.50	1	75A	LF1010	1	95	
LYS2CC	#2 Str.	0.75		100A	LF1014		LF1014	97
LYS1CC	#1 Str.							98
LYS25C	1/0 Str.							99
LYS26C	2/0 Str.							100
LYS27C	3/0 Str.	1.00		200A	LF2019		LF2019	101
LYS28C	4/0 Str.							15
LYS29C	250 kcmil							16
LYS30C	300 kcmil		2			300A		LF2038
LYS31C	350 kcmil	18						
LYS32C	400 kcmil	19						
LYS34C	500 kcmil	20						

* Fuse link supplied is selected on the basis of a minimum blowing current of approximately twice the NEC rubber insulated cable rating. Refer to Time Current curves shown and specify if another size is desired.

** The standard end bushing supplied is for maximum cable insulation diameters as shown. Compact cable will require a bushing with a smaller inside diameter to accommodate the smaller insulation diameter of the cable. If other than standard bushing is required, contact customer service.

To specify a fast acting limiter in any configuration insert a "F" before the conductor number (e.g., YFSF34CR specifies a 1/2 thick limiter section).

Replaceable Link MOLIMITER™, Type LYM
With Ceramic Shell and Rubber Sleeve for Insulated Cables

The Replaceable Link MOLIMITER™ is used to fuse underground cables at junction points with the BURNDY® MOLE™. The "Replaceable Link" feature permits the selection of one of several links. In addition, the replacement of links that have burned clear is both rapid and inexpensive. For use with both rubber and paper insulated cables. The MOLE™ end of the MOLIMITER™ is installed in the MOLE™ Socket and Nut Assembly, while the cable socket end is HYPRESS™ installed, see table below for proper installation.

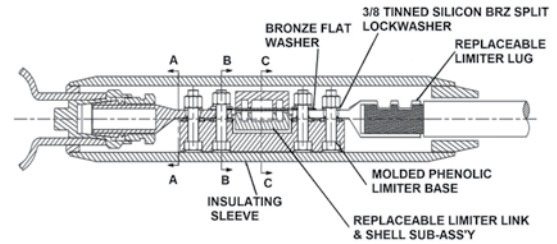

Catalog Number	Cable Size	** (Max. Cable Dia. Over Insul. Inches) A	Number of Indents in Cable Socket	* Link Supplied		For Connection to MOLE™ Use		Installation Information	
				Ampere Capacity	Catalog Number	Socket & Nut Assembly	Z Cone	No. of Indents	Installation Die Index Number
						Catalog Number	Catalog Number		
LYM2CC	2 Str.	0.75	1	100A	LF1014	Z28NR	Z2828	1	97
LYM1CC	1 Str.				LF1014				98
LYM25C	1/0 Str.			150A	LF1025				99
LYM26C	2/0 Str.				LF1025				100
LYM27C	3/0 Str.	1.00	1	200A	LF2019	Z29NR	Z2929	2	101
LYM28C	4/0 Str.			250A	LF2027				15
LYM29C	250 kcmil				LF2027				16
LYM30C	300 kcmil	1.25	2	300A	LF2038	Z30NR	Z3030	2	17
LYM31C	350 kcmil				LF2038	Z32NR	Z3132		18
LYM32C	400 kcmil			400A	LF2065	Z32NR	Z3232		19
LYM34C	500 kcmil				LF2065	Z34NR	Z3434		20

* Fuse link supplied is selected on the basis of a minimum blowing current of approximately twice the NEC rubber insulated cable rating. Refer to Time Current curves shown and specify if another size is desired.

** The standard end bushing supplied is for maximum cable insulation diameters as shown. Compact cable will require a bushing with a smaller inside diameter to accommodate the smaller insulation diameter of the cable. If other than standard bushing is required, contact customer service.

Limiter Link, Type LF

For Use with All Replaceable Limiters

Made of pure copper, the Limiter Link is controlled dimensionally to close tolerances to maintain accurate fusing characteristics. Refer to Time-Current Characteristic curve shown below and specify rating desired. The Limiter Link is supplied enclosed in a shell with heatproof chamber to confine and break the arc created by fusing.

*Catalog Number	Ampere Capacity
LF1006	50A
LF1010	75A
LF1014	100A
LF1025	150A
LF2019	200A
LF2027	250A
LF2038	300A
LF2065	400A
LF2108	500A

* For use with LYS and LYM.

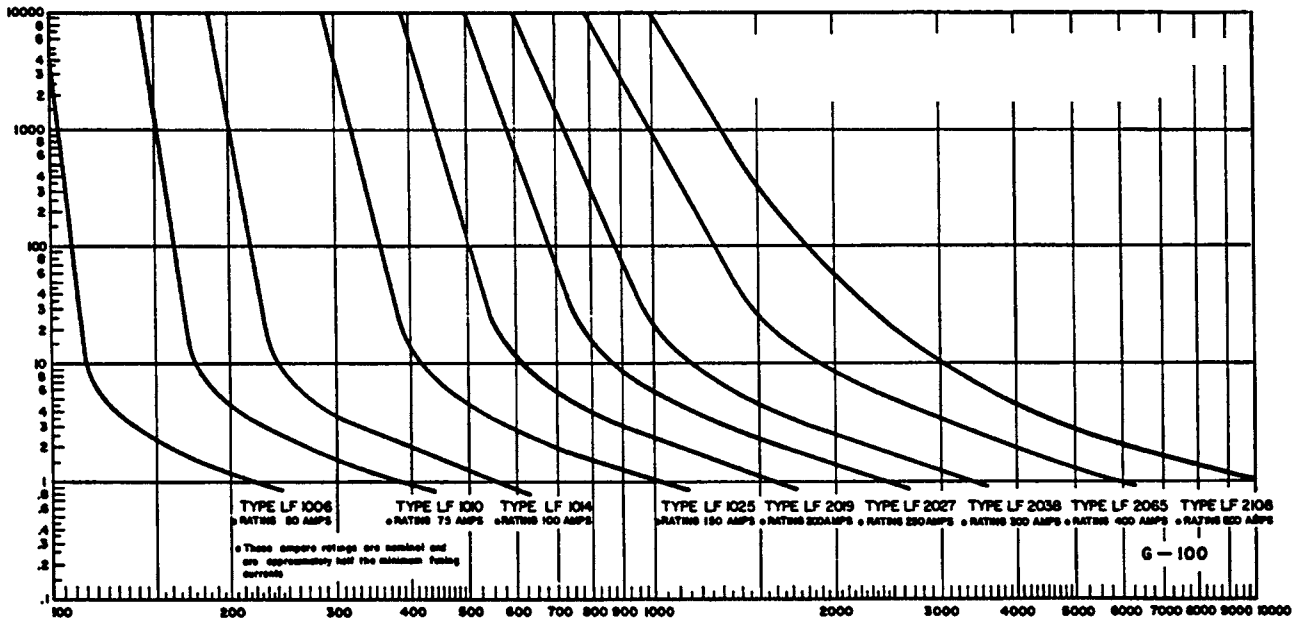
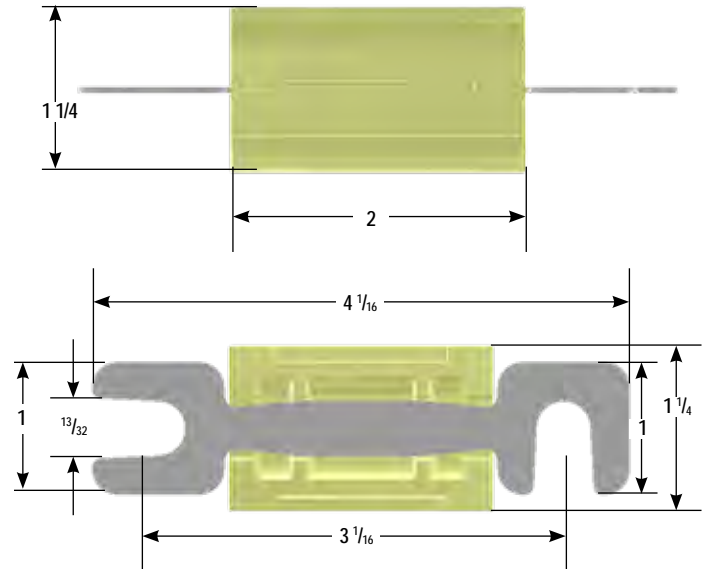

Current in Amperes

Time-Current Fusing Characteristics of Type LF Limiter Links

The nominal current ratings of these Limiter Links are approximately one-half the minimum currents required to clear the fuses. The general slope and shape of the curves are similar to those of the time-current curves of the Limiters. The Type LF Limiter Links are made of pure copper with dimensions carefully controlled in order to maintain accurate fusing characteristics.

Limiter Base, Type LYBASEH

For Use with All Replaceable Limiters

A heat resisting, high impact, molded phenolic base for mounting HYDENT™ Cable lugs or MOLIMITER™-lugs. The bases are supplied with bolts fitted in place with retaining rings, enabling the lugs to be easily assembled to BURNDY® Replaceable Limiter Links. They may be purchased separately for use with all Replaceable Limiters.

Catalog Number	For Use with
LYBASEH	LYM
	LYS

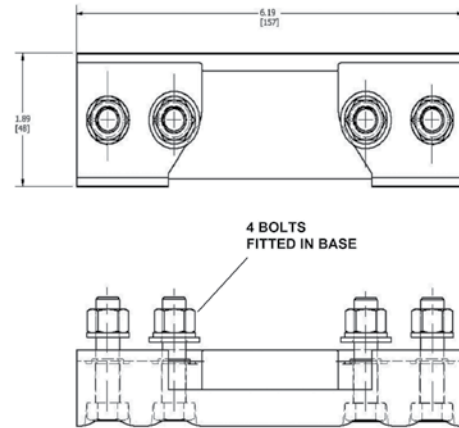

Limiter Sleeve, Type LYS34P2

For Use with All Replaceable Limiters

A molded sleeve for insulating the Replaceable Limiter and MOLIMITER™ assemblies. Similar to other component parts, the insulating sleeves may be purchased separately. These sleeves are used in conjunction with the LYS-P6 bushings.

Catalog Number	For Use with
LYS34P2	LYS
	LYM

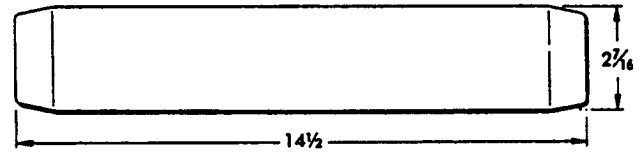

HYLUG™ Terminal, Type LYS-P5

For Use with All Replaceable Limiters

Fabricated of high copper alloy, this terminal has a sealed cable socket for use with paper insulated, oil-impregnated cables as well as rubber-insulated cables. Tin plated to retard corrosion and prevent discoloration. The HYLUG™ is for use with LYS and LYM.

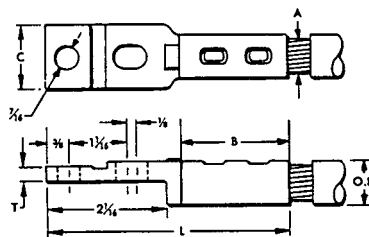

Catalog Number	Cable Size A	Dimensions in Inches					Installation Information	
		B	C	L	T	O.D.	No. of Indents	Installation Tool Index Number
LYS6CP5	#6 Str.	1-1/4	3/4	3-9/16	3/16	5/16	1	94
LYS4CP5	#4 Str.			3-5/8		11/32		95
LYS2CP5	#2 Str.			1-9/32		3-3/4		13/32
LYS1CP5	#1 Str.	1-3/8		3-29/32		15/32		98
LYS25P5	1/0 Str.			3-15/16		17/32		99
LYS26P5	2/0 Str.	1-1/2	13/16	4-1/16		9/16		100
LYS27P5	3/0 Str.		29/32			5/8		101
LYS28P5	4/0 Str.	1-5/8	1-1/8	4-3/16		11/16		15
LYS29P5	250 kcmil					3/4		16
LYS30P5	300 kcmil					2		1-3/8
LYS31P5	350 kcmil	4-9/16	7/8	18				
LYS32P5	400 kcmil		2-1/8	1-9/16	4-11/16		31/32	19
LYS34P5	500 kcmil	2-1/4	4-13/16	1-1/16	20			

Bushing, Type LYM34P3

For Use with All Replaceable Limiters

Type LYM34P3 is for assembly of Replaceable MOLIMITERS™ to the MOLE™ outlet. It fills the space between Limiter sleeve and the MOLE™ outlet to allow easy taping.

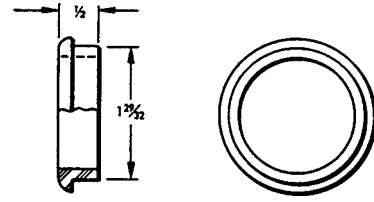

Catalog Number	For Use with	MOLE™ Outlet Size
LYM34P3	LYM	A
	LZM	

Bushing, Type LYS-P6

For Use with All Replaceable Limiters

The LYS-P6 bushing is designed to fit closely over the cable insulation when used with the LYS34P2 Limiter sleeve. It fills the space between the Limiter sleeve and cable. The tapered bushing facilitates taping at installation.

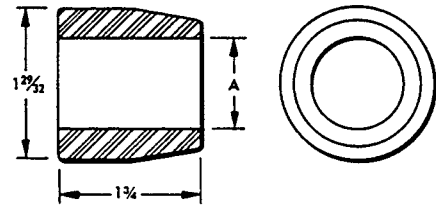

Catalog Number	(Max. Cable Dia. Over Insul.) A	For Use with
LYS32P6	1/2	LYS LYM
LYS48P6	3/4	
LYS64P6	1	
LYS80P6	1-1/4	

T-Connector, Type NYT Cable Run / Cable Tap

A "T" connector designed to provide a clamp type element on the run and a permanent HYPRESS™ connection on the tap. Recommended for use on ring buses or for applications where occasional disconnects from the run conductor are desired without disturbing the tap connection. Tin plated. For proper installation of tap cable, see table below.

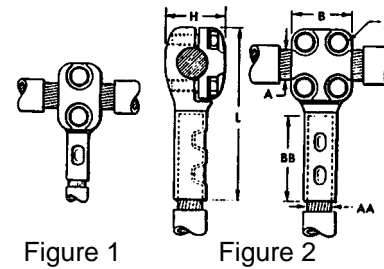

Figure 1

Figure 2

Catalog Number	Conductor Size		Fig. No.	Dimensions in Inches					Installation Information	
									HYPRESS™ & Indentor Die	
	Run A	Tap AA		B	BB	H	J	L	Y34B with Y34PR	
									Nest Die	
NYT282C	4/0 AWG	2/0 AWG	1	1-3/8	1-1/4	1-3/8	3/8	3-3/16	B2CD	1
NYT2825		1/0	1	1-3/8	1-3/8	1-3/8	3/8	4	B25D	1
NYT2826		2/0 AWG	1	1-3/8	1-1/2	1-3/8	3/8	4-1/8	B26D	1
NYT2828		4/0 AWG	2	2	1-5/8	1-3/8	3/8	4-5/16	B28D	1
NYT292C	250 kcmil	2/0 AWG	1	1-3/8	1-1/4	1-7/16	3/8	3-3/16	B2CD	1
NYT2925		1/0	1	1-3/8	1-3/8	1-7/16	3/8	4-1/16	B25D	1
NYT2926		2/0 AWG	1	1-3/8	1-1/2	1-7/16	3/8	4-3/16	B26D	1
NYT2928		4/0 AWG	2	2	1-5/8	1-7/16	3/8	4-3/8	B28D	1
NYT2929	250 kcmil	2	2	1-5/8	1-7/16	3/8	4-7/16	B29D	1	
NYT3125	350 kcmil	1/0	1	1-3/8	1-3/8	1-1/2	3/8	4-1/8	B25D	1
NYT3126		2/0 AWG	1	1-3/8	1-1/2	1-1/2	3/8	4-5/16	B26D	1
NYT3128		4/0 AWG	2	2	1-5/8	1-1/2	3/8	4-1/2	B28D	1
NYT3129		250 kcmil	2	2	1-5/8	1-1/2	3/8	4-9/16	B29D	1
NYT3131	350 kcmil	2	2	2	1-1/2	3/8	5	B31D	2	
NYT3426	500 kcmil	2/0 AWG	1	1-3/8	1-1/2	1-5/8	3/8	4-7/16	B26D	1
NYT3428		4/0 AWG	2	2	1-5/8	1-5/8	3/8	4-5/8	B28D	1
NYT3429		250 kcmil	2	2	1-5/8	1-5/8	3/8	4-5/8	B29D	1
NYT3431		350 kcmil	2	2	2	1-5/8	3/8	5-1/16	B31D	2
NYT3434	500 kcmil	2	2	2-1/4	1-5/8	3/8	5-3/8	No Nest Die Req'd.	2	
NYT3926	750 kcmil	2/0 AWG	1	1-3/8	1-1/2	1-7/8	3/8	4-5/8	B26D	1
NYT3928		4/0 AWG	2	2	1-5/8	1-7/8	3/8	4-13/16	B28D	1
NYT3929		250 kcmil	2	2	1-5/8	1-7/8	3/8	4-13/16	B29D	1
NYT3931		350 kcmil	2	2	2	1-7/8	3/8	5-1/4	B31D	2
NYT3934	500 kcmil	2	2	2-1/4	1-7/8	3/8	5-9/16	No Nest Die Req'd.	2	
NYT3939	750 kcmil	2	2	2-7/8	1-7/8	3/8	6-1/4	—	2	
NYT4426	1000 kcmil	2/0 AWG	1	1-3/8	1-1/2	2-1/8	3/8	4-3/4	B26D	1
NYT4428		4/0 AWG	2	2	1-5/8	2-1/8	3/8	4-15/16	B28D	1
NYT4429		250 kcmil	2	2	1-5/8	2-1/8	3/8	5	B29D	1
NYT4431		350 kcmil	2	2	2	2-1/8	3/8	5-7/16	B31D	2
NYT4434	500 kcmil	2	2	2-1/4	2-1/8	3/8	5-3/4	No Nest Die Req'd.	2	
NYT4439	750 kcmil	2	2	2-7/8	2-1/4	3/8	6-3/8	—	2	
NYT4444	1000 kcmil	2	2-11/16	3	2-5/16	1/2	7	—	2	
NYT4628	1500 kcmil	4/0 AWG	2	2	1-5/8	2-11/16	3/8	5-3/8	B28D	1
NYT4629		250 kcmil	2	2	1-5/8	2-11/16	3/8	5-7/16	B29D	1
NYT4631		350 kcmil	2	2	2	2-11/16	3/8	5-7/8	B31D	2
NYT4634		500 kcmil	2	2	2-1/4	2-11/16	3/8	6-3/16	No Nest Die Req'd.	2
NYT4639	750 kcmil	2	2	2-7/8	2-11/16	3/8	6-3/4	—	2	
NYT4644	1000 kcmil	2	2	3	2-3/4	1/2	7-1/8	—	2	
NYT4646	1500 kcmil	2	2-11/16	3-3/16	2-3/4	1/2	7-11/16	—	2	

High Capacity Limiter - 200,000 Amperes at 600 Volts

The BURNDY® High Capacity Limiter is designed to economically protect electrical distribution systems from the destructive effect of high energy faults. The increasing number of 600 volt secondary network installations for industrial and commercial applications demand a cable limiter that can safely interrupt 200,000 amperes (symmetrical available) and one that will also completely coordinate with the higher voltage network protector fuses.

Available fault currents as high as 200,000 amperes rms at 600 volts across the fusible elements have been interrupted during tests on the BURNDY® High Capacity Limiter. The power factor during these tests was less than 15%, thereby imposing the most difficult clearing conditions. No external disturbance is experienced upon clearing fault currents from the "float" value to 200,000 amperes. The quartz tiller absorbs the intense energy generated by interrupting the fault current. The quartz fuses into tubular fulgurites, with a high dielectric strength, and forms an insulating barrier between the melted link sections. This action prevents restrike of the internal arc. The rugged aluminum housing and cast epoxy end seals provide a vessel that completely contains the developed energy.

The carefully developed time-current characteristics and rigid manufacturing tolerances assure proper coordination with the network protector fuses and the insulation damage characteristics of 4/0, 250, 350, 500 kcmil and 750 cable.

The High Capacity Limiter is available in four variations to accommodate a variety of installation practices. The Type HYS cable sockets at both ends, which allow for indenting to the cable ends with a hydraulic BURNDY® HYPRESS™. The HYA has an off-set lug on one end which permits back-to-back mounting on bus bar. They HYA also allows cable to installation with no off-set.

For those installations where BURNDY® MOLE™ connections are used for manhole junctions or transformer vault buses, the Type HYM permits a replaceable connection of the limiter director to the MOLE™ outlet at one end and a compression cable connection at the other.

Modern electrical distribution systems require low cost protection to safeguard costly equipment and quickly isolate faults, so that the undamaged portions of the system may function normally. BURNDY® High Capacity Limiters assure positive, economical protection when installed in properly designed systems.

NOTE: Today's fault currents are growing. If you need higher fault current ratings, please contact the factory.

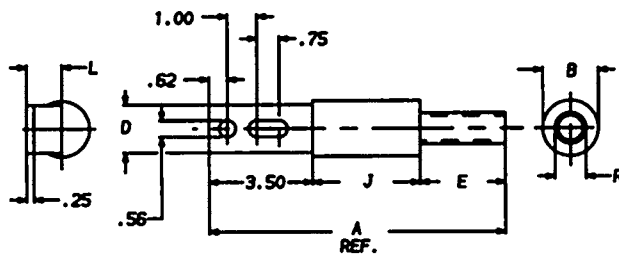

Offset Bus to Cable
Type HYAO
Figure 1

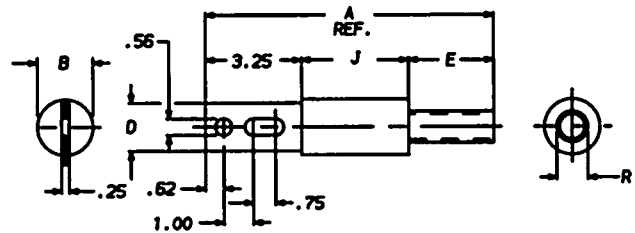

Bus to Cable
Type HYA
Figure 2

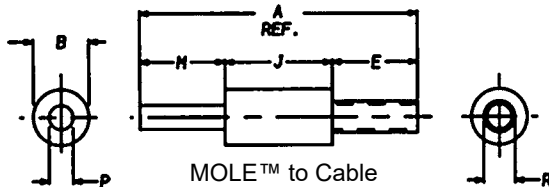

MOLE™ to Cable
Type HYM
Figure 3

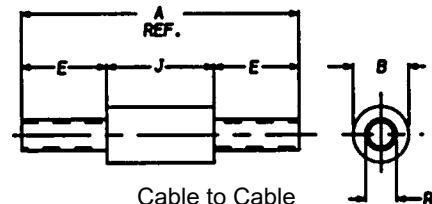

Cable to Cable
Type HYS
Figure 4

High Capacity Limiter 200,000 Amperes at 600 Volts

④ Catalog Number	Cable Size	Fig. No.	A		B		D		E		J		L		M		P		R		Die Index	Die	No. of Crimps per End
			In	mm	In	mm	In	mm	In	mm	In	mm	In	mm	In	mm	In	mm	In	mm			
H Yao_28	4/0	1	8.87	225	1.44	37	1.12	28	1.75	44	3.62	92	0.96	24	—	—	—	—	0.68	17	15	U28RT	2
H Yao_29	250 kcmil	1	9.00	229	1.44	37	1.12	28	1.88	48	3.62	92	0.96	24	—	—	—	—	0.75	19	16	U29RT	2
H Yao_31	350 kcmil	1	9.12	232	1.62	41	1.12	28	2.00	51	3.62	92	0.96	24	—	—	—	—	0.88	22	18	U31RT	4
H Yao_34	500 kcmil	1	10.00	254	1.88	48	1.62	41	2.88	73	3.62	92	1.19	30	—	—	—	—	1.05	27	20	U34RT	4
H Yao_39	750 kcmil	1	10.13	257	2.50	64	2.00	51	2.88	73	3.75	95	1.31	33	—	—	—	—	1.32	34	24	U39RT	4
H YA_28	4/0	2	8.62	219	1.44	37	1.12	28	1.75	44	3.62	92	—	—	—	—	—	—	0.68	17	15	U28RT	2
H YA_29	250 kcmil	2	8.75	222	1.44	37	1.12	28	1.88	48	3.62	92	—	—	—	—	—	—	0.75	19	16	U29RT	2
H YA_31	350 kcmil	2	8.87	225	1.62	41	1.12	28	2.00	51	3.62	92	—	—	—	—	—	—	0.88	22	18	U31RT	4
H YA_34	500 kcmil	2	9.75	248	1.88	48	1.62	41	2.88	73	3.62	92	—	—	—	—	—	—	1.05	27	20	U34RT	4
H YA_39	750 kcmil	2	9.88	251	2.50	64	2.00	51	2.88	73	3.75	95	—	—	—	—	—	—	1.32	34	24	U39RT	4
H YM_28	4/0	3	7.87	200	1.44	37	—	—	1.75	44	3.62	92	—	—	2.50	64	0.52	13	0.68	17	15	U28RT	2
H YM_29	250 kcmil	3	8.00	203	1.44	37	—	—	1.88	48	3.62	92	—	—	2.50	64	0.58	14	0.75	19	16	U29RT	2
H YM_31	350 kcmil	3	8.12	206	1.62	41	—	—	2.00	51	3.62	92	—	—	2.50	64	0.68	17	0.88	22	18	U31RT	4
H YM_34	500 kcmil	3	9.38	238	1.88	48	—	—	2.88	73	3.62	92	—	—	2.88	73	0.81	21	1.05	27	20	U34RT	4
H YM_39	750 kcmil	3	9.51	242	2.50	64	—	—	2.88	73	3.75	95	—	—	2.88	73	1.00	25	1.32	34	24	U39RT	4
H YS_28	4/0	4	7.12	180	1.44	37	—	—	1.75	44	3.62	92	—	—	—	—	—	—	0.68	17	15	U28RT	2
H YS_29	250 kcmil	4	7.38	188	1.44	37	—	—	1.88	48	3.62	92	—	—	—	—	—	—	0.75	19	16	U29RT	2
H YS_31	350 kcmil	4	7.62	194	1.62	41	—	—	2.00	51	3.62	92	—	—	—	—	—	—	0.88	22	18	U31RT	4
H YS_34	500 kcmil	4	9.38	238	1.88	48	—	—	2.88	73	3.62	92	—	—	—	—	—	—	1.05	27	20	U34RT	4
H YS_39	750 kcmil	4	9.51	242	2.50	64	—	—	2.88	73	3.75	95	—	—	—	—	—	—	1.32	34	24	U39RT	4

Notes:

1. For insulated version add suffix "-C" to Catalog Number (example: HYMS34C).
2. High Capacity Limiter. 200kA interrupting capacity at 600V AC.
3. Cable end utilize dies with 35, 46, 45, and 750 series tools (750 kcmil size units cannot be installed with the 35 Series tools).
- ④ For fast operating limiter use "F"; for slow or standard operating limiter use "S" before conductor number (example: HYMF34 or HYMS34) see Time-Current Characteristics.
5. For other conductor sizes, contact the factory.

For over 85 years, BURNDY has pioneered and produced economical, dependable connectors and protective devices for urban underground distribution systems. This extensive experience has been applied to the development of equipment for low cost underground distribution systems for light commercial and residential areas.

Increasing interest by home buyers and developers has created a need for URD components comparable in cost with those used in overhead systems.

Using connectors designed for other purposes, early URD installations were relatively expensive. Recognizing the need to reduce installation costs, BURNDY developed a line of connectors specifically for URD.

These products are shown in this section. They are the result of a continuing search for new materials and more efficient production methods to bring down cost to meet the requirements of low cost underground construction.

Type RDMD-2858D Stud MOLE™ Junction with Adapter

The RDMD-2858D Stud MOLE™ is identical to the insulated RDMD-28G except an adapter is supplied, allowing MOLE™ to be removed from transformer stud without disconnecting the individual services.

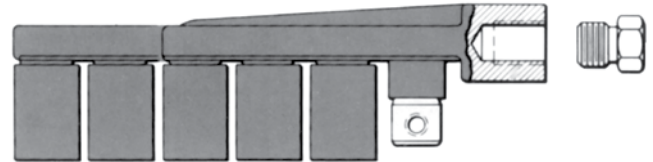

Catalog Number	Number of Outlets	Insulated
RDMD42858D	4	Yes

Type RDM-28 URD MOLE™ for Aluminum or Copper

Type RDM-28 MOLE™ is an economical, insulated, submersible service junction suitable for direct burial or for use in enclosures. Disconnectable joints allow additions of new services without disturbing previous installations. Taping is eliminated, heat-shrink or force-fit rubber sleeves insulate each joint. Rubber is used to insulate the MOLE™ body. Removable sealing covers are supplied on all outlets but two. REA listed Tap Kits, including HYLUG™, hardware and sleeve are ordered separately.

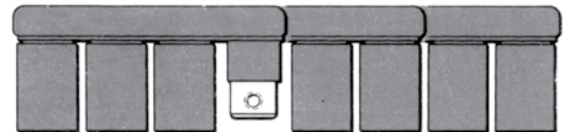

Catalog Number	Number of Outlets
RDM428	4
RDM628	6
RDM828	8

Types RA6UC-SL, RA6UCR-SL URD Street Lighting Tap Kit for Aluminum or Copper

URD tap kit for making street lighting taps from URD MOLE™ types RDM-28 and RDM-28T. Each kit accommodates 6 str. - 12 sol. Kits include connector, mounting hardware and insulating sleeve.



Catalog Number		Conductor
Heat Shrink	Force Fit	
RA6UCSL	RA6UCRSL	6 Str. - 12 Sol.

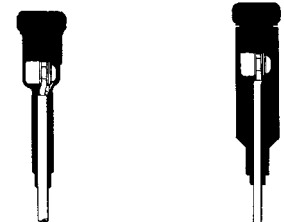

MOLE™ Tap Kits, Types RYA-UC, RYA-AC

For Aluminum or Copper with Type RDM-28
URD MOLE™

The kit consists of Universal HYLUG™, mounting hardware and heat-shrink sleeve. The HYLUG™ is pre-filled with PENETROX™ joint compound and sealed. Installed with common installation tools, three die sets install a range of 4 str.-350 kcmil. The heatshrink sleeve is lined with a mastic material, providing a positive seal. Installed with standard propane torch, or 500°F electric heat gun. Acetylene heat is too intense and is not recommended.



TYPES RYA-UC, RYA-AC



TYPES RYA-UCR, RYA-ACR

MOLE™ Tap Kits, Types RYA-UCR, RYA-ACR

With Force Fit Rubber Sleeve

The kit consists of Universal HYLUG™, mounting hardware and pre-lubricated force fit rubber sleeve. The HYLUG™ is pre-filled with PENETROX™ joint compound and sealed. Installed with common installation tools, three die sets install a range of 4 str.-350 kcmil. The rubber sleeve has internal sealing rings that provide a positive moisture seal by exerting circumferential force on cable and MOLE™ insulation. Pre-lubricating sleeve makes installation easier. REA listed. No trimming required.

Catalog Number			Conductor		EEI Die Index	Die Index	Tools, Die Set Catalog Number & (Number of Crimps)		
Heat Shrink Complete Set	Force Fit Shrink Sleeve Only	Force Fit Complete Set	Copper	Aluminum			MD6 Series	35, 750 Series	OUR840
RYA4UC	RYAC25	RYA4UCR	2 Sol.-4 Str.	2 Sol. - 4 Str. 4 Str. Comp	8A	BG or 5/8-1 or 243	WBG (1) BG3 or W243	UBG (1) UK581T (3) U243 (1)	XBG (3) XNBG (2)
RYA2UC	RYAC25	RYA2UCR	2 Str. - 1/0 Sol.	2 Str. - 1/0 Sol. 2-1 Str. Comp					
RYA25UC	RYAC25	RYA25UCR	1/0 Str.	1/0 Str. - 2/0 Sol. 1/0 Str. Comp.					
RYA2WAC	RYAC25	RYA2WACR	—	2 Sol. EC-O	—	BG	BG (5)	—	XBG (5) XNBG (3)
RYA75AC	RYAC25	RYA75ACR	—	1/0 Sol. EC-O	—	—	—	UK581T (5)	XNBG (3)
RYA26UC	RYAC31	RYA26UCR	2/0 Str.	2/0 Str. 2/0 Str. Comp.	11	249 or 840	W249 (3) WK840 (5)	U249 (2) UK840T (3)	X249 (6) X840 (5)
RYA27UC	RYAC31	RYA27UCR	3/0 Str.	3/0 Str. 3/0 Str. Comp. 4/0 Sol. EC-O	11				
RYA28UC	RYAC31	RYA28UCR	4/0 Str.	4/0 Str. 4/0 Str. - 250 Comp.	11				
RYA29UC	RYAC31	RYA29UCR	250 kcmil	250 250 Comp.	13A	299 or 655 or 705	—	U31ART (2) U655 (3) U705 (2)	—
RYA31AC	RYAC31	RYA31ACR	—	300 - 350 300 - 350 Comp.	13A	—	—	—	—

* Overlap Crimps.

** Do not use EEI Die. (11A) to install 4/0 Sol. EC-O.

NOTE: Standard mounting hardware is 3/8" button head socket cap screw with captive conical washer. For HEX HEAD bolt with captive conical washer add "HEX" suffix.

Example:

RYA4UCR-HEX. For HEX HEAD bolt and captive flat washer add suffix "HEX1".

For HEX HEAD bolt and non-captive flat washer add suffix "HEX2".

For HEX HEAD bolt and non-captive conical washer add suffix "HEX3".

For Stainless Steel HEX HEAD bolt add "HEX355" suffix.

URD Insulated Splice Kit, Type YS-CG
For All Aluminum or Copper/Aluminum Combinations

Type YS-CG URD insulated splice kit consists of a standard YSU or YSD LINKIT™ and a heat-shrink sleeve. Used to splice URD secondary lines up to 600 volts. It is installed with common installation tools. Heat-shrink sleeve is installed with standard propane torch, or 500° F electric heat gun. Acetylene is not recommended.

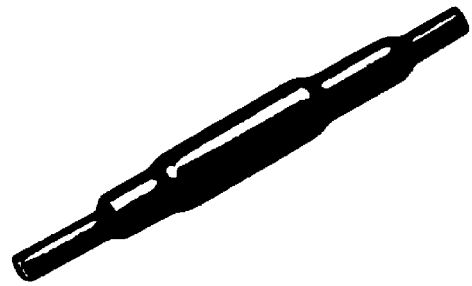

Catalog Number		Conductor			Die Index	Tools, Die Set Catalog Number, & (No. of Crimps)	
Complete Splice Kit	Heat Shrink Sleeve	Both Sides				MD6 Series	35, 750 Series
		Aluminum	ACSR	Copper *			
YS2UCG1	RYAC25	1-2 Str.	2 (6-1, 7-1)	1-2 Str.	BG 243	BG (3) WBG (1)** W243 (2)	UBG(1)** U243 (1)
YS25UCG1		1/0 Str. 1/0 Comp.	1/0 (6-1)	1/0 Str.			
YS26UCG1	RYAC311	2/0 Str. 2/0 Comp.	2/0 (6-1)	2/0 Str.	249/840	W249 (4) WK840 (7)	U249 (2) UK840T (4)
YS27UCG1		3/0 Str. 3/0 Comp.	3/0 (6-1)	3/0 Str.			
YS28UCG1		4/0 Str. 4/0 Comp.	4/0 (6-1)	4/0 Str.			
YS31ACG1	RYAC31	350 350 Comp.	—	350	299/705	—	U299 (2) U705 (1)

* Use to join copper to aluminum or ACSR not copper to copper.

** Multiple crimp die set makes more than one crimp per compression.

HYREDUCER™ Splice, Type YRB-U For Aluminum to Aluminum and Aluminum to Copper

Type YRB-U splice is designed for use within underground systems. Aluminum splices are tin-plated and recommended for use on Aluminum-to-Aluminum and Aluminum-to-Copper cables. All splices have solid center stop for use with oil filled and non-oil filled cables. The Outside Diameter is held constant to minimize installation dies and connectors are prefilled with PENETROX™. Rated up to 35 kV.

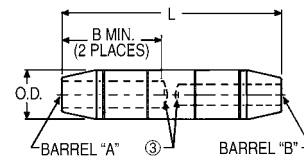

Catalog Number	Conductor Range		Dimensions		O.D.	Wire Strip Length		Die Index	Color Code
	Barrel "A" Copper & Aluminum	Barrel "B" Copper & Aluminum	B Min.	L		Barrel "A"	Barrel "B"		
YRB2U3TTN	#2 (.292 Dia.) 7 Str.	#3 (.260 Dia.) 7 Str.	1.35 [34]	3.25 [83]	0.65 [17]	1-3/4"	1-3/4"	296	Tan
YRB1CU2TTN	#1 (.332 Dia.) 19 Str. or 1/0 Compact (.336 Dia.) 19 Str.	#2 (.292 Dia.) 7 Str.							
YRB1CU1TTN	#1 (.332 Dia.) 19 Str. or 1/0 Compact (.336 Dia.) 19 Str.	#1 (.332 Dia.) 19 Str. or 1/0 Compact (.336 Dia.) 19 Str.							
YRB25U3TTN	1/0 (.373 Dia.) 19 Str. or 1/0 Compact (.336 Dia.) 19 Str.	#3 (.260 Dia.) 7 Str.							
YRB25U2TTN	1/0 (.373 Dia.) 19 Str. or 1/0 Compact (.336 Dia.) 19 Str.	#2 (.292 Dia.) 7 Str.							
YRB25U25TTN	1/0 (.373 Dia.) 19 Str. or 1/0 Compact (.336 Dia.) 19 Str.	1/0 (.373 Dia.) 19 Str. or 1/0 Compact (.336 Dia.) 19 Str.							
YRB27U25TW	3/0 (.470 Dia.) 19 Str. or 3/0 Compact (.423 Dia.) 19 Str.	1/0 (.373 Dia.) 19 Str. or 1/0 Compact (.336 Dia.) 19 Str.	1.53 [39]	3.69 [94]	0.85 [22]	1-1/2"	1-1/2"	298	White
YRB28U3TW	4/0 (.528 Dia.) 19 Str. or 4/0 Compact (.475 Dia.) 19 Str.	#3 (.260 Dia.) 7 Str.							
YRB28U1TW	4/0 (.528 Dia.) 19 Str. or 4/0 Compact (.475 Dia.) 19 Str.	#1 (.332 Dia.) 19 Str. or 1/0 Compact (.336 Dia.) 19 Str.							
YRB28U25TW	4/0 (.528 Dia.) 19 Str. or 4/0 Compact (.475 Dia.) 19 Str.	1/0 (.373 Dia.) 19 Str. or 1/0 Compact (.336 Dia.) 19 Str.							
YRB28U26TW	4/0 (.528 Dia.) 19 Str. or 4/0 Compact (.475 Dia.) 19 Str.	2/0 (.419 Dia.) 19 Str. or 2/0 Compact (.376 Dia.) 19 Str.							
YRB28U28TW	4/0 (.528 Dia.) 19 Str. or 4/0 Compact (.475 Dia.) 19 Str.	4/0 (.528 Dia.) 19 Str. or 4/0 Compact (.475 Dia.) 19 Str.							
YRB31U25TW	350 kcmil (.681 Dia.) 37 Str. or 350 kcmil Compact (.616 Dia.) 19 Str. Al; 37 Str. Al & Cu	1/0 (.373 Dia.) 19 Str. or 1/0 Compact (.336 Dia.) 19 Str.	2.34 [59]	5.43 [138]	1.11 [28]	2-1/4"	2-1/4"	299	Brown
YRB31U28TW	350 kcmil (.681 Dia.) 37 Str. or 350 kcmil Compact (.616 Dia.) 19 Str. Al; 37 Str. Al & Cu	4/0 (.528 Dia.) 19 Str. or 250 kcmil Compact (.520 Dia.) 37 Str.							
YRB31U31TW	350 kcmil (.681 Dia.) 37 Str. or 350 kcmil Compact (.616 Dia.) 19 Str. Al; 37 Str. Al & Cu	350 kcmil (.681 Dia.) 37 Str. or 350 kcmil Compact (.616 Dia.) 19 Str. Al; 37 Str. Al & Cu							

1. Material: Aluminum.
2. Finish: Electro-tin plated.
3. Barrels are partially filled with PENETROX™ and sealed.
4. Scratch brushing of all conductors before making installation is recommended.
5. Not for use with Copper-to-Copper applications.
6. Dimensions in brackets [] are in millimeters rounded off to the nearest millimeter, unless otherwise noted and are for reference only.
7. Catalog number PT6515 Adaptor is required to use "U" dies in 45 series tools.
8. Catalog number PUADP1 Adaptor is required to use "U" dies in 46 series tools.
9. On MY293 HYTOOL™ use alum. Index plate settings as follows, for 1/0 conductor use 1/0 setting. For conductor smaller than 1/0 size use 2/0 setting.

HYREDUCER™ Splice, Type YRB-U
(Continued)

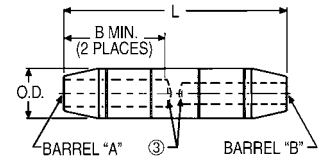

Catalog Number	Conductor Range		Dimensions			Wire Strip Length		Die Number	Color Code
	Barrel "A" Copper & Aluminum	Barrel "B" Copper & Aluminum	B Min.	L	O.D.	Barrel "A"	Barrel "B"		
YRB34U25TW	500 kcmil (.813 Dia.) 37 Str. or 500 kcmil Compact (.736 Dia.) 19 Str. Al; 37 Str. Al & Cu	1/0 (.373 Dia.) 19 Str.	2.70 [69]	6.00 [152]	1.31 [33]	1-1/8"	1-1/8"	300	Pink
YRB34U28TW	500 kcmil (.813 Dia.) 37 Str. or 500 kcmil Compact (.736 Dia.) 19 Str. Al; 37 Str. Al & Cu	4/0 (.528 Dia.) 19 Str. or 4/0 Compact (.475 Dia.) 19 Str.							
YRB34U29TW	500 kcmil (.813 Dia.) 37 Str. or 500 kcmil Compact (.736 Dia.) 19 Str. Al; 37 Str. Al & Cu	250 kcmil (.575 Dia.) 37 Str.							
YRB34U30TW	500 kcmil (.813 Dia.) 37 Str. or 500 kcmil Compact (.736 Dia.) 19 Str. Al; 37 Str. Al & Cu	300 kcmil (.630 Dia.) 37 Str.							
YRB34U31TW	500 kcmil (.813 Dia.) 37 Str. or 500 kcmil Compact (.736 Dia.) 19 Str. Al; 37 Str. Al & Cu	350 kcmil (.681 Dia.) 37 Str. or 350 kcmil Compact (.616 Dia.) 19 Str. Al; 37 Str. Al & Cu							
YRB34U34TW	500 kcmil (.813 Dia.) 37 Str. or 500 kcmil Compact (.736 Dia.) 19 Str. Al; 37 Str. Al & Cu	500 kcmil (.813 Dia.) 37 Str. or 500 kcmil Compact (.736 Dia.) 19 Str. Al; 37 Str. Al & Cu							
YRB39U31TW	700 kcmil (.964 Dia.) 61 Str., 750 kcmil (.998 Dia.) 61 Str. or 750 kcmil Compact (.908 Dia.) 61 Str.	350 kcmil (.681 Dia.) 37 Str. or 350 kcmil Compact (.616 Dia.) 19 Str. Al; 37 Str. Al & Cu	2.87 [73]	6.74 [171]	1.46 [37]	3"	3-11/16"	936	Yellow
YRB39U34TW	700 kcmil (.964 Dia.) 61 Str., 750 kcmil (.998 Dia.) 61 Str. or 750 kcmil Compact (.908 Dia.) 61 Str.	500 kcmil (.813 Dia.) 37 Str. or 500 kcmil Compact (.736 Dia.) 19 Str. Al; 37 Str. Al & Cu							
YRB39U39TW	700 kcmil (.964 Dia.) 61 Str., 750 kcmil (.998 Dia.) 61 Str. or 750 kcmil Compact (.908 Dia.) 61 Str.	700 kcmil (.964 Dia.) 61 Str., 750 kcmil (.998 Dia.) 61 Str. or 750 kcmil Compact (.908 Dia.) 61 Str.							
YRB44U31TW	1000 kcmil (1.152 Dia.) 61 Str.	350 kcmil (.681 Dia.) 37 Str. or 350 kcmil Compact (.616 Dia.) 19 Str. Al; 37 Str. Al & Cu							
YRB44U34TW	1000 kcmil (1.152 Dia.) 61 Str.	500 kcmil (.813 Dia.) 37 Str. or 500 kcmil Compact (.736 Dia.) 19 Str. Al; 37 Str. Al & Cu							
YRB44U39TW	1000 kcmil (1.152 Dia.) 61 Str.	700 kcmil (.964 Dia.) 61 Str., 750 kcmil (.998 Dia.) 61 Str. or 750 kcmil Compact (.908 Dia.) 61 Str.							
YRB44U44TW	1000 kcmil (1.152 Dia.) 61 Str.	1000 kcmil (1.152 Dia.) 61 Str.							

1. Material: Aluminum.
2. Finish: Electro-tin plated.
3. Barrels are partially filled with PENETROX™ and sealed.
4. Scratch brushing of all conductors before making installation is recommended.
5. Not for use with Copper-to-Copper applications.
6. Dimensions in brackets [] are in millimeters rounded off to the nearest millimeter, unless otherwise noted and are for reference only.
7. Catalog number PT6515 Adaptor is required to use "U" dies in 45 series tools.
8. Catalog number PUADP1 Adaptor is required to use "U" dies in 46 series tools.
9. On MY293 HYTOOL™ use alum. Index plate settings as follows, for 1/0 conductor use 1/0 setting. For conductor smaller than 1/0 size use 2/0 setting.

HYREDUCER™ Splice, Type YRB-U (Continued)

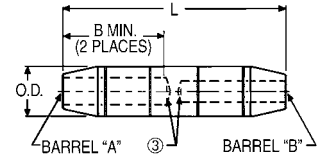

Installation (Number of Crimps per End)						
Color Code	Die Index	Hydraulic				Dieless (# of Crimps)
		35, 750 Series	46 Series	45 Series	60 Ton Series	
Tan	296	U25ART (1)	U25ART (1)	U25ART (1)	—	Mechanical: MY29 Series (1) Hydraulic: 644 Series (1), 444 Series (1)
White	298	U28ART (2)	U28ART (2)	U28ART (2)	—	
Brown	299	U31ART Overlap Crimp	U31ART Overlap Crimp	U31ART Overlap Crimp	L31ART (1)	644 Series (1) 444 Series (1)
Pink	300	U34ART Overlap Clamp	U34ART Overlap Clamp	U34ART Overlap Clamp	L34ART	
Yellow	936	U39ART2 (4)	U39ART2 (4)	U39ART2 (4)	L39ART (2)	—

1. Material: Aluminum.
2. Finish: Electro-tin plated.
3. Barrels are partially filled with PENETROX™ and sealed.
4. Scratch brushing of all conductors before making installation is recommended.
5. Not for use with Copper-to-Copper applications.
6. Dimensions in brackets [] are in millimeters rounded off to the nearest millimeter, unless otherwise noted and are for reference only.
7. Catalog number PT6515 Adaptor is required to use "U" dies in 45 Series tools.
8. Catalog number PUADP1 Adaptor is required to use "U" dies in 46 Series tools.
9. On MY293 HYTOOL™ use alum. Index plate settings as follows, for 1/0 conductor use 1/0 setting. For conductor smaller than 1/0 size use 2/0 setting.

HYREDUCER™ Splice, Type YRB-T
For Copper to Copper

Type YRB-T splice is designed for use within underground systems. Copper splices are tapered and recommended for use on copper-to-copper cables.

All splices have solid center stops for use with oil filled and non-oil filled cables.

The Outside Diameter is held constant to minimize installation dies. Rated up to 35 kV

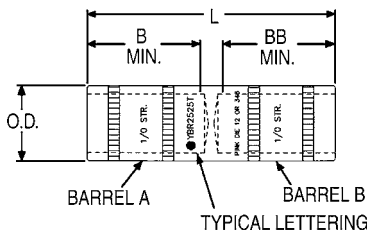

Fig. 1

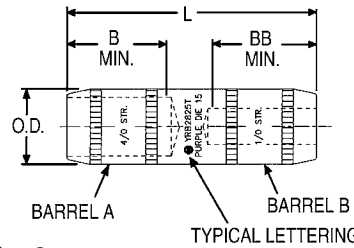

Fig. 2

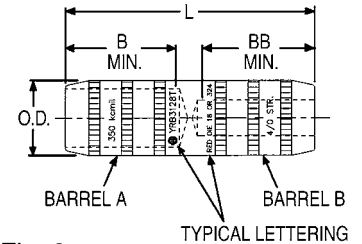

Fig. 3

Catalog Number ② ⑦	Figure No.	Conductor Size		Dimensions			
		Barrel "A"	Barrel "B"	B Min.	BB Min.	L	O.D.
YRB2825T	2	4/0 (0.53)	1/0 (0.37)	1.16 [29]	1.16 [29]	2.84 [73]	0.69 [18]
YRB3428T	3	500 kcmil	4/0 (0.53)	1.73 [44]	1.73 [44]	4.50 [114]	1.06 [27]

② ⑦ Catalog Number	Color Code	Installation Tooling (Number of Crimps)										Dieless (# of Crimps)	Wire Strip Length
		Die Information		Mechanical			Hydraulic						
		Die Index	Type	OUR840	MD7 MD734R	MD6	35, 750 Series	BCT500, Y500CT	④ 46 Series	③ 45 Series	60 Series		
YRB2825T	Purple	Die 15	Purple Die Set	X28VT (4) X28RT (4)	X28VT (4)	X28VT (4)	U28RT (1)	—	U28RT (1)	—	L29ART (1)	Hydraulic: 644 Series (1) 444 Series (1)	1-7/32"
YRB3428T	Brown	Die 20 or 299	Brown Die Set	—	—	—	U34ART (2) U31ART (2)	W34VT (2) W34RT (2)	U34RT (2) U31ART (2)	U34RT (2) U31ART (2)	L34RT (1)	Hydraulic: 644 Series (1) 444 Series (1)	1-13/16"

- 1 Material: Copper.
- ② For Tin-Plating, add suffix "TN" to the Catalog Number (example: YRB2825TN). For Hot Tin dipped add suffix "W" to the catalog number (example: YRB2825TW).
- ③ Catalog number PT6515 Adaptor is required to use "U" type dies in the 45 series tools
- ④ Catalog number PUADP1 Adaptor is required to use "U" type dies in the 46 series tools
- 5 Dimensions in brackets [] are in millimeters rounded off to the nearest millimeter, unless otherwise specified, and are for reference only.
- ⑦ Suffix "TN" and "W" will not be stamped on part.

URD Service Tap, Type K-P-C For Copper Conductors

These compact, wide-range-taking, multiple outlet connectors are made of high conductivity copper alloy. Spherical point Allen set screws provide even clamping forces on conductors up to 4/0 Str. Each connector is supplied with an insulating cover. The mechanical clamping elements allow individual cables to be disconnected without disturbing adjacent connections.

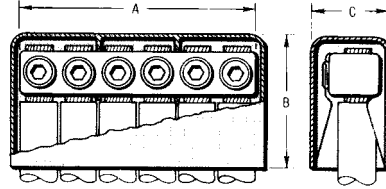

Catalog Number			Conductor	Number of Outlets	A	B	C
Complete Assembly	Connector Only	Cover Only					
K6P28C	K6P28	KPC28	6 Str - 4/0 Str.	6	5-1/8	2-3/4	1-5/8