



Ergonomic and material handling products

Increase safety & productivity

Introduction

Ergonomics Pays Dividends	2
---------------------------	---

Workstation Kits & Accessories

Update Your Existing Bench	3
ERGO™ Tool Balancers	4-5
ERGO™ Tapered Drum Tool Balancers	6-7
Accessories for ERGO-3 BH Tool Balancers	8
Single Column Workstation Kits	9-10
Straight Rail Bench Leg Kits	11
Straight Rail Bench Top Kits	12
Curved Rail Follows The Work	13-14
4 Ft LED Workbench Light & Power Bars	15-16
Add Accessories to Your Kit	17
Adjustable Foot Rest	18
Work Lights and Power Bars	19-20
Add Accessories to Your Kit	21-22
TORQ-ARM for Assembly Tools	23-25
Tool Positioners	26-27
250 lb. Capacity Rail	28-29
Heavy Duty Tool Cranes	30-31

Jibs

Jib Kits: Bench Or Floor Mounted, 30 Lb. Capacity	32-33
Jib Kits: Floor mounted, 50 lb. capacity, 6' - 18' booms	34-35
Jib Kits: Floor mounted, 150-300 lb. capacity, 6' - 10' booms	36-37
Ceiling mounted, 50 lb. capacity jib kits	38-39

Components

Aluminum Track Components	40-41
Steel Track, 30 lb.	41-42
Steel Track, 50 lb.	44-45
Booms and Mounting Bases	46-47
Retrievers	48-49

Mobile Kits

Minimize Reaching for Parts	50-51
Heavy-Duty Special Purpose Carts	52-53
Steel Track, 50 lb.	44-45
Booms and Mounting Bases	46-47

Ergonomics Pays Dividends

Proper material handling and workplace ergonomics increase profitability through efficiency, productivity, and cost reduction.

According to the U.S. Bureau of Labor Statistics, 33% of workplace injuries each year result from poor ergonomics. OSHA describes the problem as a mismatch between workers' physical capacity and the physical demands of their jobs. The most reported musculoskeletal disorders (MSDs) include carpal tunnel syndrome, tendonitis, and back injuries. OSHA identifies five basic risk factors:

Repetition: Repeating the same motions for two hours or more at a time, or using a device steadily for more than four hours daily.

Force: Lifting more than 75 lbs at any one time or pushing/pulling with more than 20 lbs of initial force.

Awkward Postures: Raising hands above the head repeatedly for more than two hours a day, or working with back, neck, or wrists bent for more than two hours total per day.

Contact Stress: Using hand or knee as a hammer more than ten times an hour for more than two hours total per day.

Vibration: Using tools with high vibration levels (like chain saws or jack hammers) for more than 30 minutes per day or tools with moderate vibration (like jigsaws or grinders) for more than two hours per day.



ToolAssistPro

The science of ergonomics fits tasks to people. Notice how time plays a role in each risk factor. MSD symptoms appear over time. By the time a worker feels pain, it may be too late to avoid injury. Workers should rotate frequently between tasks.

Make sure workstations fit individual workers to eliminate lifting and reaching. Properly equipped, configurable workstations connect task rotation and workplace customization.

The relatively small investment required to properly outfit your workstations pays off. Experience fewer injuries with reduced liability, less tool damage, improved employee morale, and increased production.

ToolAssistPro products solve ergonomic and material handling problems. Our broad, fully equipped product line is the most comprehensive offering on the market. We're your single source for workplace solutions.

Update Your Existing Bench

Quick and easy, inexpensive retrofits for old or new benches



Kits

ToolAssistPro kits include everything you need to assemble ergonomically-sound workstations or mobile carts. The only tools required are two wrenches and a tape measure. Drilling may be required to secure workstation to some benches. All fasteners are included. To complete assembly, attach bases to the bench, slide components into position and tighten hardware. Three base styles are available. Customize your workstation to fit the task and fit the people performing the task, using available components and accessories.

Older bench equipped with new workstation kit and optional accessories.

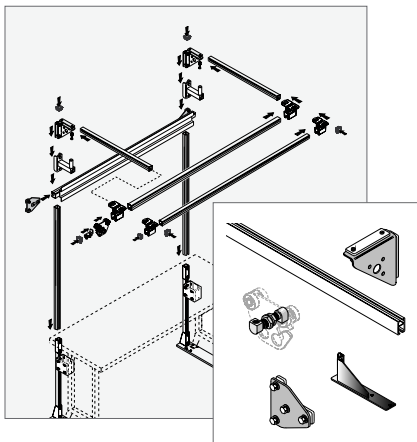

Components

Most **ToolAssistPro** workstation components are available separately. Add them to basic kits, customizing them to fit the task. Components assemble using the practical “slide & clamp” assembly method. Where applicable, components include track nuts, clamp bars, or other hardware required for assembly.

Kits, components and accessories assemble easily. Just slide into place and tighten.



Accessories

Increase utilitarian value and make the workplace user-friendly by adding functions with **ToolAssistPro** workstation accessories. They install easily on fixed or mobile workstation kits. Typical accessories include:

- Adjustable swing arms with a variety of attachments
- Torque neutralizing arms and tool positioners
- Air manifolds
- Bars for holding plastic tote bins, shelves
- Lights

Mobile productivity booster kits are complete, including all hardware. Assembly is required.

ERGO™ Tool Balancers

Make Tools Weightless

Reliable & Economical ERGO-1 Series



Economical **ERGO-1 "BD" TOOL BALANCERS** support tools weighing up to 5 lbs (2.3kg). Molded ABS housing has a smooth exterior with rounded edges for ergonomic appeal. These modern, reliable balancers are easy to adjust and feature world-class functions.

SEVEN WAYS BETTER:

1. Hand-windable spring tension adjusting knob is flush with the housing
2. Push-button tension release simplifies decrease of spring tension
3. Rugged steel upper swivel hook with provision for secondary safety cable
4. Over-sized cable opening with direct in-line pull to reduce cable wear
5. 270 lb (121.5kg) test 0.047" (1.2mm) dia. 7 x 7 strand galvanized steel aircraft cable nylon covered to 0.063" (1.6mm) O.D
6. Adjustable cable stop and lower safety hook
7. Matte black finish minimizes reflections to reduce eye strain

SERIES "BD" DIMENSIONS

All dimensions in inches (mm)

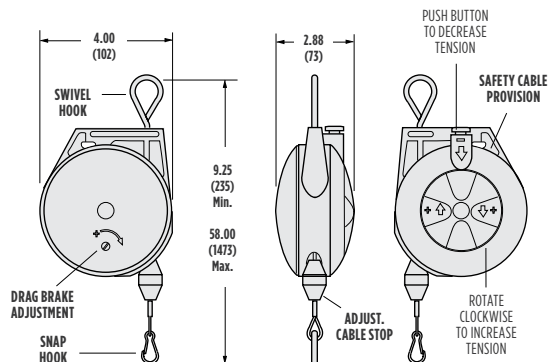

Heavy-duty ERGO-2 Series



ERGO-2 "BG" REELS feature rugged steel construction with with baked black polyester finish, reinforced hanging bracket with forged clevis for ceiling mounting and extra holes for attaching safety chain. Spring is permanently lubricated and provides constant tension, adjustable for balancing tool in normal working zone (6 - 18 in. [152-457mm]). Cable is 920 lb. (414kg) test 0.09" (2.3mm) dia. 7 x 7 strand galvanized steel aircraft cable nylon covered to 0.12" (3.0mm) O.D. Includes safety tool clip and adjustable cable stop.

LOCKING MODELS include all features listed above plus a positive ratchet lock mechanism to allow locking of the cable at a specific height. A slight pull on the cable releases the lock which functions like a window shade. Lock feature may be disengaged externally when constant tension is required.

SERIES "BG" DIMENSIONS

All dimensions in inches (mm)

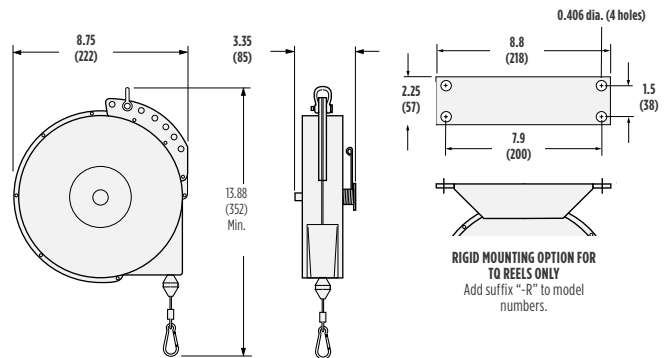

ERGO™ Tool Balancers *continued*

Make Tools Weightless

Reliable & Economical ERGO-1 Series

SELECTION CHART			
MIN - MAX LOAD lbs. / (kg.)	CABLE LENGTH* ft. / (m.)	REEL WEIGHT lbs. / (kg.)	MODEL NUMBER
0.5 - 1.5 (0.2 - 0.7)	6 (1.8)	1.3 (0.6)	BD-01
1.5 - 3.0 (0.5 - 1.4)	6 (1.8)	1.3 (0.6)	BD-03
3.0 - 5.0 (1.4 - 2.3)	6 (1.8)	1.5 (0.7)	BD-05

*Cable lengths listed are for "active" or "working cable." Includes cable stop and safety hook.

Balancer Accessories



ADJUSTABLE CABLE SADDLE

Hangs from balancer cable above tool to provide strain relief for electrical cable or air hose. Available in three sizes. Includes safety clip.

CABLE DIAMETER in. (mm)	MODEL NO.
0.3 - 0.59 (7 - 14)	CS-F1
0.6 - 0.94 (15 - 23)	CS-F2
0.95 - 1.25 (24 - 31)	CS-F3



#STC-01 SAFETY CLIP

Bright zinc plated steel safety latch for tool attachment and other uses. Measures 2.375" (60mm) long. One included with each BG reel. Rated capacity-70 lbs.



CLEVIS HANGERS

#CVF-01 CLEVIS

#CVF-11 SWIVEL CLEVIS

Galvanized forged steel hangers for mounting balancers, torque reels, etc. Measure 0.50" (13mm) between jaws. One #CVF-01 straight clevis included with each "BG" & "TQ" reel. #CVF-11 swivel clevis is optional extra. Pins included. Rated capacity-500 lbs.

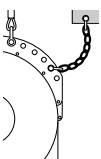

SAFETY CABLE/CHAIN

Strongly recommended, secondary steel cable or steel link chain. Prevents balancer from accidental fall. Balancers have extra holes for cable or chain.

*Nylon covered steel cable. / **Steel link chain.

LENGTH ft. (m)	MODEL NO.
1.0 (0.3)	SC-BD1*
1.0 (0.3)	SC-BG1**
2.0 (0.6)	SC-BG2**
3.0 (0.9)	SC-BG3**

Heavy-duty ERGO-2 Series

SELECTION CHART				
MIN - MAX LOAD lbs. / (kg.)	CABLE LENGTH* ft. / (m.)	RATCHET LOCK	REEL WT. lbs. / (kg.)	MODEL NUMBER
BALANCERS (CONSTANT PULL REELS) May be adjusted to balance through 6-18 in. (152-457mm) range.				
3 - 7 (1.4 - 3.2)	8 (2.4)	No	6 (2.7)	BG-03
5 - 10 (2.3 - 4.5)	8 (2.4)	No	6 (2.7)	BG-07
8 - 12 (3.6 - 5.4)	8 (2.4)	No	7 (3.2)	BG-10
10 - 15 (4.5 - 6.8)	8 (2.4)	No	8 (3.6)	BG-15
16 - 23 (7.2 - 10.4)	8 (2.4)	No	8 (3.6)	BG-20
16 - 23 (7.2 - 10.4)	8 (2.4)	No	8 (3.6)	BG-20SH**
22 - 27 (9.9 - 12.2)	8 (2.4)	No	8 (3.6)	BG-25
RETRACTORS (RATCHET LOCK) Retract tool upward when manually released				
3 - 7 (1.4 - 3.2)	8 (2.4)	Yes	6 (2.7)	BG-03-L
5 - 10 (2.3 - 4.5)	8 (2.4)	Yes	6 (2.7)	BG-07-L
8 - 12 (3.6 - 5.4)	8 (2.4)	Yes	7 (3.2)	BG-10-L
10 - 15 (4.5 - 6.8)	8 (2.4)	Yes	8 (3.6)	BG-15-L
16 - 23 (7.2 - 10.4)	8 (2.4)	Yes	8 (3.6)	BG-20-L
16 - 23 (7.2 - 10.4)	8 (2.4)	Yes	8 (3.6)	BG-20-LSH**
22 - 27 (9.9 - 12.2)	8 (2.4)	Yes	8 (3.6)	BG-25-L
TORQUE REELS (RATCHET LOCK AND LONGER CABLE)				
3 - 7 (1.4 - 3.2)	15.0 (4.5)	Yes	8 (3.6)	TQ1507***
5 - 10 (2.3 - 4.5)	15.0 (4.5)	Yes	10 (4.5)	TQ1510***
10 - 15 (4.5 - 6.8)	15.0 (4.5)	Yes	12 (5.4)	TQ1515***

*Cable lengths listed are "active" or "working" cable.

**Includes BG-SH "Shock Stop". See Below.

***Clevis mount. For rigid mount add "-R" to model number.

Balancer Accessories

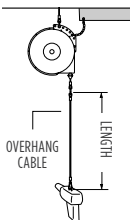

OVERHANG CABLE

Nylon covered steel cable with safety clip. Brings tool closer to work area without unwinding cable from reel or mounting reel at a lower height.

LENGTH ft. (m)	MODEL NO.
3 (0.9)	OC-03
5 (1.5)	OC-05
10 (3.0)	OC-10
15 (4.6)	OC-15



"SHOCK STOP" SHOCK ABSORBER

MODEL NO. BG-SH

Minimize cable damage often caused by overtensioning tool balancers. "Shock Stop" kit is easily installed. Can be used on any Series BG balancer. Kit includes spring, cable stops, all hardware.

ERGO™ Tapered Drum Tool Balancers

Drum compensates for changing spring rates

Heavy-duty construction. Spring powered, no motors or expensive gear trains to wear out or break. Tapered drum compensates for changing spring rate.

ERGO-3 “BH” Tapered Drum tool balancers keep tools within reach. Reduce damage to tools by suspending them out of the way above the work surface. Risk of repetitive motion injury is reduced because only a light, downward force is required to place the tool in proper operating position. As the tool is lowered, and the spring is wound more tightly, the effective drum diameter increases to compensate for the increased force. When properly adjusted, the tapered drum keeps the tool at the positioned height.

FEATURES INCLUDE:

- Rugged diecast aluminum housing
- Both top and bottom hooks have spring-loaded safety latches
- Heavy duty steel wire rope
- Automatic safety catch prevents free-spooling if springs fail (not available on BH-02/BH-05)
- Easy adjusting with everyday tools from outside housing



MODELS “BH-02”
THROUGH “BH-05”



MODELS “BH-09”
THROUGH “BH-70”



MODELS “BH- 85”
THROUGH “BH-140”

ERGO™ Tapered Drum Tool Balancers *continued*

Drum compensates for changing spring rates

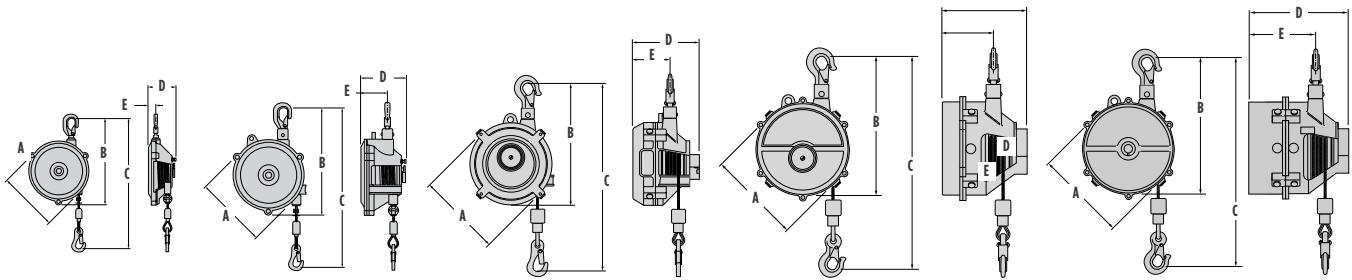

BH-02

BH-03/BH-05

BH-09/BH-70

BH-85

BH-100/BH-140

SELECTION CHART			
For Tool Weighing*	Cable Travel	Shipping Weight	Model Number
1.1 - 4.4 lbs.	3.3 ft.	2.2 lbs.	BH-02
2.2 - 6.6 lbs.	4.3 ft.	2.8 lbs.	BH-03
5.5 - 11 lbs.	4.3 ft.	3.3 lbs.	BH-05
9 - 20 lbs.	3.9 ft.	13.4 lbs.	BH-09
20 - 33 lbs.	3.9 ft.	13.4 lbs.	BH-15
33 - 48 lbs.	4.5 ft.	22.6 lbs.	BH-22
48 - 66 lbs.	4.5 ft.	22.6 lbs.	BH-30
66 - 88 lbs.	4.5 ft.	27.0 lbs.	BH-40
88 - 110 lbs.	4.5 ft.	27.0 lbs.	BH-50
110 - 132 lbs.	4.5 ft.	31.4 lbs.	BH-60
132 - 154 lbs.	4.5 ft.	31.4 lbs.	BH-70
154 - 187 lbs.	4.5 ft.	58.4 lbs.	BH-85
187 - 220 lbs.	4.5 ft.	56.0 lbs.	BH-100
220 - 264 lbs.	4.5 ft.	60.0 lbs.	BH-120
264 - 308 lbs.	4.5 ft.	61.0 lbs.	BH-140

*Tool weight includes hose or cord and other attachments which must be supported by balancer.

DIMENSIONAL CHART					
Model	A	B	C**	D	E
BH-02	5.00 in.	7.25 in.	11.25 in. min.	1.81 in	0.81 in
BH-03/BH-05	5.83 in.	8.25 in	12.50 in. min.	2.72 in.	1.44 in
BH-09/BH-15	7.00 in.	10.00 in.	13.00 in. min.	5.50 in.	2.88 in
BH-22/BH-70	8.60 in.	12.60 in.	17.00 in. min.	6.40 in.	3.19 in.
BH-85	9.50 in.	14.00 in.	20.00 in. min	9.75 in.	5.38 in
BH-100/BH-140	9.50 in.	14.00 in.	21.00 in. min	9.75 in.	5.38 in

**Minimum height fully retracted, inside of hook to inside of hook.

SAFETY CHAIN (RECOMMENDED)		
Description	Shipping Weight	Model Number
2.0 ft. Steel Link Chain w/ Clevises	1.5 lbs.	SC-EH2
3.0 ft. Steel Link Chain w/ Clevises	2.0 lbs.	SC-EH3

Accessories for ERGO-3 BH Tool Balancers

SERIES BH TOOL BALANCER ACCESSORIES					
Balancer Model No.	Capacity		Safety Chain	Overhang Cable (4)	Tool Trolley
	Lbs.	(Kg)			
BH-02 (1)	1.1 - 4.4	(0.5 - 2.0)	NONE	OC-XX	WS30-BTL (6)
BH-03 (1)	2.2 - 6.6	(1.0 - 3.0)	SC-BG3	OC-XX	WS30-BTL (6)
BH-05 (1)	5.5 - 11	(2.5 - 5.0)	SC-BG3	OC-XX	WS30-BTL (6)
BH-09 (1)	9 - 20	(4.1 - 9.1)	SC-BG3	OC-XX (5)	WS50-BTL
BH-15 (2)	20 - 33	(9.1 - 15)	SC-BG3	OC-XX (5)	WS50-BTL
BH-22 (2)	33 - 48	(15 - 21.8)	SC-BG3	OC5MB-XX	WS50-BTL
BH-30 (2)	48 - 66	(21.8 - 30.0)	SC-BG3	OC5MB-XX	WS60-BT
BH-40 (2)	66 - 88	(30.0 - 40.0)	SC-BH3	OC5MB-XX	WS60-BT
BH-50 (2)	88 - 110	(40.0 - 50.0)	SC-BH3	OC5MB-XX	WS60-BT
BH-60 (2)	110 - 132	(50.0 - 60.0)	SC-BH3	OC5MB-XX	WS60-BT
BH-70 (2)	132 - 154	(60.0 - 70.0)	SC-BH3	OC5MB-XX	WS60-BT
BH-85 (2)	154 - 187	(70.0 - 85.0)	SC-BH3	OC8MB-XX	WS60-BT
BH-100 (3)	187 - 220	(85.0 - 100.0)	SC-BH3	OC8MB-XX	W6S-BT
BH-120 (3)	220 - 264	(100.0 - 120.0)	SC-BH3	OC8MB-XX	W6S-BT
BH-140 (3)	264 - 308	(120.0 - 140.0)	SC-BH3	OC8MB-XX	W6S-BT

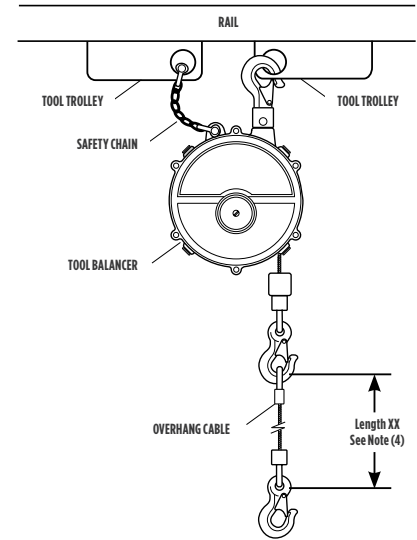

- (1) Balancer hook will fit WS30-BTL or WS50-BTL Tool Trolley.
- (2) Balancer hook will fit either WS50-BTL, WS60-BT or W6S-BT Tool Trolley.
- (3) Balancer hook will fit only W6S-BT Tool Trolley.
- (4) "XX" = Length req'd. When ordering indicate, -03 = 3 ft., -05 = 5 ft. or -10 = 10 ft.
- (5) Use with BH-09 or BH-15 requires one additional SCT-O1 Safety Clip.
- (6) WS50-BTL may also be used with BH-02, BH-03 and BH-05.

Repair Parts for ERGO-3 BH Tool Balancers

BH-09 - 70 BALANCERS	
MODEL #	DESCRIPTION
BH09-SPG	SPRING FOR BH-09
BH15-SPG	SPRING FOR BH-15
BH22-SPG	SPRING FOR BH-22
BH30-SPG	SPRING FOR BH-30
BH40-SPG	SPRING FOR BH-40
BH50-SPG	SPRING FOR BH-50
BH60-SPG	SPRING FOR BH-60
BH70-SPG	SPRING FOR BH-70
BH915-CBL	CABLE FOR BH-09 & BH-15
BH2270-CBL	CABLE FOR BH-22 THRU BH-70
BH915-DRM	DRUM FOR BH-09 & BH-15
BH2270-DRM	DRUM FOR BH-22THRU BH-70

BH-02 - 05 BALANCERS	
MODEL #	DESCRIPTION
BH02-SPG	SPRING W/DRUM FOR BH-02
BH03-SPG	SPRING W/DRUM FOR BH-03
BH05-SPG	SPRING W/DRUM FOR BH-05
BH02-CBL	CABLE FOR BH-02
BH03-CBL	CABLE FOR BH-03
BH05-CBL	CABLE FOR BH-05

BH-85 - 140 BALANCERS	
MODEL #	DESCRIPTION
BH85-SPG	SPRING FOR BH-85
BH100-SPG	SPRING FOR BH-100
BH120-SPG	SPRING FOR BH-120
BH140-SPG	SPRING FOR BH-140
BH85140-DRM	DRUM W/CABLE FOR BH-85 THRU BH-140

Single Column Workstation Kits

Swing or fixed booms

SINGLE COLUMN KITS offer an efficient way to meet ergonomic requirements. Easily mount to work bench. Each kit is complete with 180° swing or fixed boom, safety hook or balancer trolley and Universal Bracket. That lets you mount everything from an air line fitting to peg board. Some models also include tool balancer, coiled air line, brass air line fitting and cord grip for use with electric tools. Customizable. Horizontal boom has maximum rated capacity of 30 lbs (13.5 kg). Bolts to any bench top. Hardware for mounting jib to bench not included. Balancer is easily adjusted to support tool weight allowing maximum productivity with minimum effort. Tool not included.

36" (914MM) LONG BOOM WORKSTATION KIT (top right) includes (1) fixed or swing 3 ft. WS30 swing boom, (1) 5 ft. WS50 vertical column, (1) 1.5, 2.5, or 5.0 lb. tool balancer, (1) balancer trolley, (1) end stop (with trolley only), (2) end caps, (1) WS-UH universal bracket, (1) brass air fitting, (1) cord grommet, (1) coiled 1/4" air line, (1) mounting base, all hardware required for assembly. Mounting fasteners not included. Does not include tool.



36" SWING BOOM KIT WITH TOOL TROLLEY

Includes everything you need except for tool & hardware to attach jib to your bench top. Swing arms may be installed on 36" jib kits

WS30 BOOM FOR TOTAL LOADS TO 30 LBS. (13.5 KG)					
Min - Max BALANCER CAPACITY	TROLLEY MODEL NUMBER	BOOM LENGTH & TYPE	VERTICAL COLUMN HEIGHT	WITH HOOK MODEL NO.	WITH TROLLEY MODEL NO.
0.5-1.5 lbs	WS30-BTS	36" Swing	5' (1.5m)	na	WTS-050301
1.5-3.0 lbs.	WS30-BTS	36" Swing	5' (1.5m)	na	WTS-050302
3.0-5.0 lbs.	WS30-BTS	36" Swing	5' (1.5m)	na	WTS-050305
0.5-1.5 lbs	WS30-BTS	36" Fixed	5' (1.5m)	na	WTF-050301
1.5-3.0 lbs.	WS30-BTS	36" Fixed	5' (1.5m)	na	WTF-050302
3.0-5.0 lbs.	WS30-BTS	36" Fixed	5' (1.5m)	na	WTF-050305
na	WS30-BTL*	24" Swing	4' (1.2m)	WHS-020400	WTS-020400
na	WS30-BTL*	24" Fixed	4' (1.2m)	WHF-020400	WTF-020400

* Only on models supplied with trolley.

ERGO 4 BT SERIES TOOL BALANCERS						
MIN - MAX LOAD (lbs)	MIN - MAX LOAD (kg)	CABLE LENGTH (ft)	CABLE LENGTH (m)	BALANCER WEIGHT (lbs)	BALANCER WEIGHT (kg)	MODEL NO.
0.9-1.75	0.4-0.8	4.4	1350	2.75	1.25	BT-9200
1.6-3.3	0.75-1.5	4.4	1350	2.9	1.3	BT-9201
2.6-5.5	1.2-2.5	4.4	1350	3	1.35	BT-9202
6.6-11	3-5	2.95	900	3.5	1.6	BT-9203

Single Column Workstation Kits *continued*

Swing or fixed booms

24" (610mm) LONG BOOM WORK STATION KIT includes (1) fixed or swing 2 ft. WS30 boom, (1) 4 ft. WS50 vertical column, (1) balancer trolley or end stop hook, (1) end stop (with trolley only), (2) end caps, (1) angle bracket (fixed boom only), (1) WS-UH universal bracket, (1) mounting base, and all assembly hardware. Fasteners for mounting base to bench not included. Does not include swing arms, balance reel, tool, air line or fittings shown in illustration.

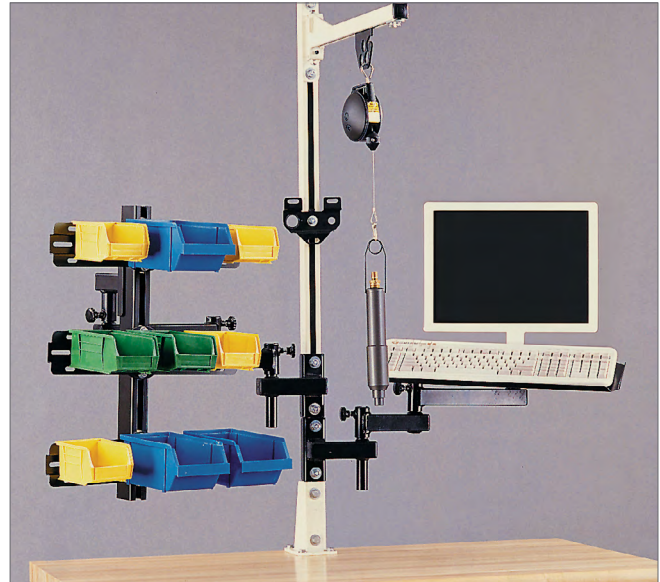
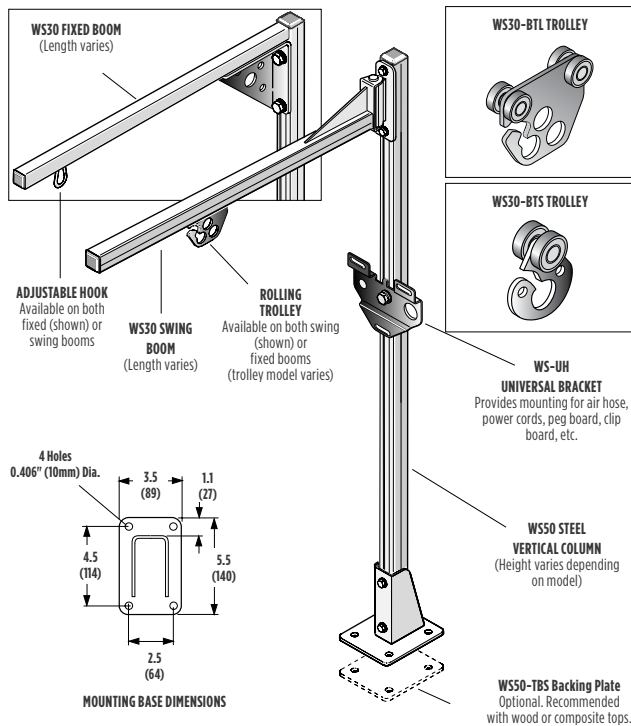

24" SWING BOOM KIT WITH TOOL TROLLEY

Includes everything you need except for tool & hardware to attach jib to your bench top. Swing arms may be installed on 36" jib kits

24" SWING BOOM KIT WITH ROLLING TROLLEY

Also available with fixed tool hook. Pictured with optional tool balancer, swing arms, white marker board and document stand. Tool and air line supplied by customer. Swing arms may also be installed on 36" jib kits.

Straight Rail Bench Leg Kits

Dual rail, dual column, bench-supported

DUAL COLUMN WORKSTATION KIT fits virtually any bench and any task. Includes two straight rails, your choice of three mounting base styles and in a range of heights to. Horizontal support rails feature adjustable height, width (distance between vertical columns), and position. Kits include one WS30 and one WS50 rail. Use either or both as tool rails by adding optional balancer trolleys. Trolley-mounted TORQ-ARM™ may be used, as can most accessories. Add more components for additional functions. Consult your **ToolAssistPro** distributor or contact the factory for more details.

TOOL RAIL KITS include (1) WS30 rail with hangers, (1) WS50 rail with hangers, (2) WS50 vertical columns, (2) WS50 horizontal 36" rails, (2) angle brackets with hardware, (2) bases as shown, (4) end stops, (8) end caps, and all assembly hardware.

STRAIGHT RAIL BENCH LEG KITS		
RAIL WIDTH ft. (m)	HEIGHT ABOVE BENCH	
	7 ft.(2.1m) (1)	7 ft.(2.1m) (1)
	30"(762) BASE	36"(914) BASE
4.0 (1.2)	#WKF-030740	#WKF-030746
5.0 (1.5)	#WKF-030750	#WKF-030756
6.0 (1.8)	#WKF-030760	#WKF-030766

NOTE 1: Nominal floor to top of vertical rail is 7'(2.1m). For 8'(2.4m) high models, change 7 in model number to 8, ie: WKF-030840.

WS30 AND WS50 TOOL RAILS

4', 5', or 6' (1.2, 1.5, 1.8m) lengths. Includes hangers, end stops, and end caps.

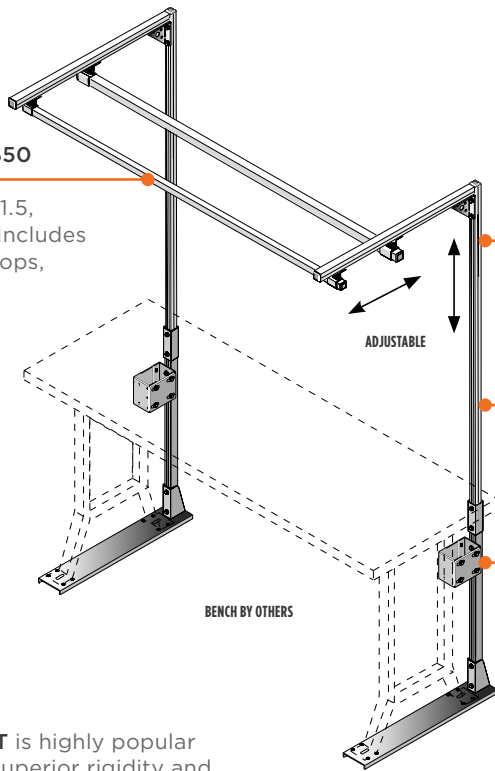

WS50 SUPPORT RAILS

3 ft.(0.9m) long. Reach full depth of bench. End caps included.

WS50 VERTICAL COLUMNS

3 ft.(0.9m) long. Reach full depth of bench. End caps included.

WS50-UF30 OR WS50-UF36 BENCH LEG BASES

Bolt or weld to bottoms and back uprights of legs. Mounting bracket fully adjustable. Available for 30" (762mm) or 36" (914mm) bench depth. Base predrilled to fit most standard benches cataloged by Edsal, Equipto, Lyon, Penco and similar manufacturers.

BENCH LEG KIT is highly popular because of its superior rigidity and durability. The bench becomes a movable workstation.

Straight Rail Bench Top Kits

Dual rail, dual column, bench-supported

DUAL COLUMN WORKSTATION KIT fits virtually any bench and any task. Includes two straight rails, your choice of three mounting base styles and in a range of heights to. Horizontal support rails feature adjustable height, width (distance between vertical columns), and position. Kits include one WS30 and one WS50 rail. Use either or both as tool rails by adding optional balancer trolleys. Trolley-mounted TORQ-ARM™ may be used, as can most accessories. Add more components for additional functions. Consult your **ToolAssistPro** distributor or contact the factory for more details.

TOOL RAIL KITS include (1) WS30 rail with hangers, (1) WS50 rail with hangers, (2) WS50 vertical columns, (2) WS50 horizontal 36" rails, (2) angle brackets with hardware, (2) bases as shown, (4) end stops, (8) end caps, and all assembly hardware.

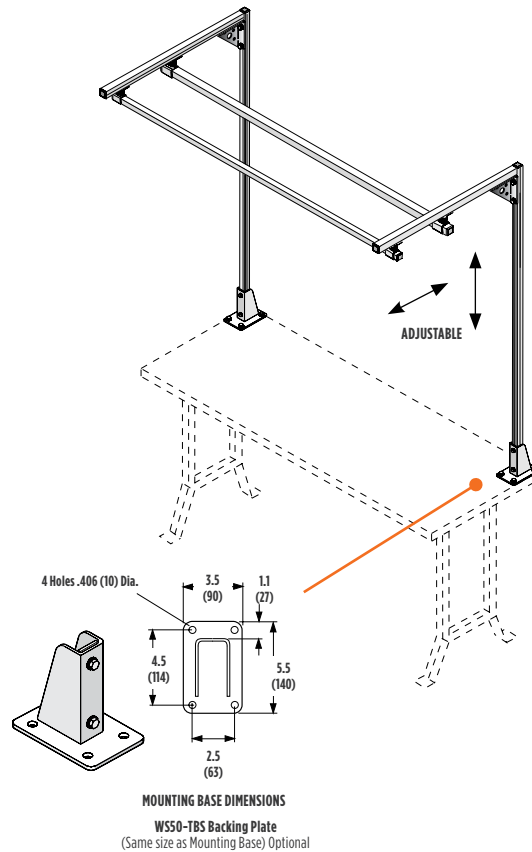

STRAIGHT RAIL BENCH TOP KITS			
RAIL WIDTH ft. (m)	HEIGHT ABOVE BENCH		
	5 ft.(1.5m) (2)	6 ft.(1.8m) (2)	
4.0 (1.2)	#WGB-030540	#WGB-030640	
5.0 (1.5)	#WGB-030550	#WGB-030650	
6.0 (1.8)	#WGB-030560	#WGB-030660	

RAIL WIDTH ft. (m)	HEIGHT ABOVE BENCH		
	5 ft.(1.5m) (2)	6 ft.(1.8m) (2)	
4.0 (1.2)	#WKB-030540	#WKB-030640	
5.0 (1.5)	#WKB-030550	#WKB-030650	
6.0 (1.8)	#WKB-030560	#WKB-030660	

Note: Height of bench will determine Tool Rail height

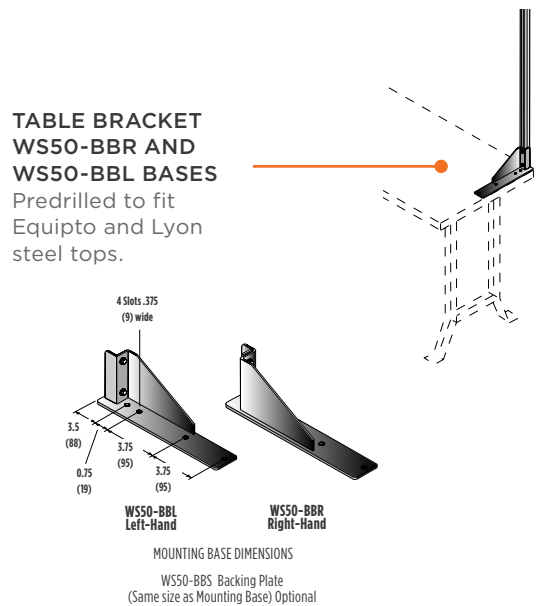

Optional for all Bench Top Kits

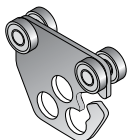

BALANCER TROLLEY
 WS30-BTL for WS30 rail.
 WS50-BTL for WS50 rail.
 Order separately.

Curved Rail follows the work

Guide tools and controls around corners

UNIQUE DIAMOND RAIL TRACK & TROLLEYS allow tools or control boxes to follow assembly line or conveyor path. Curved sections with 3 ft. (0.9m) radius form 90° corner and connect to other curved or straight track sections for smooth, non-stop trolley movement. Design and build your own system from components shown below. Threaded hangers may be hung from overhead beams or from WS50 rail using standard track nut. Trolleys include safety flanges to prevent fall if rollers fail. Capacity 30 lbs. (13.5 Kg).

WSD-SA SPLICE ANGLE KIT Includes splice angles and hardware. One bolt also serves as hanger and includes track nut which fits WS50 or WA50 rail. Can also be hung from other suitable supports. NOTE: To hang rail lower, substitute longer bolt or threaded rod (by others).

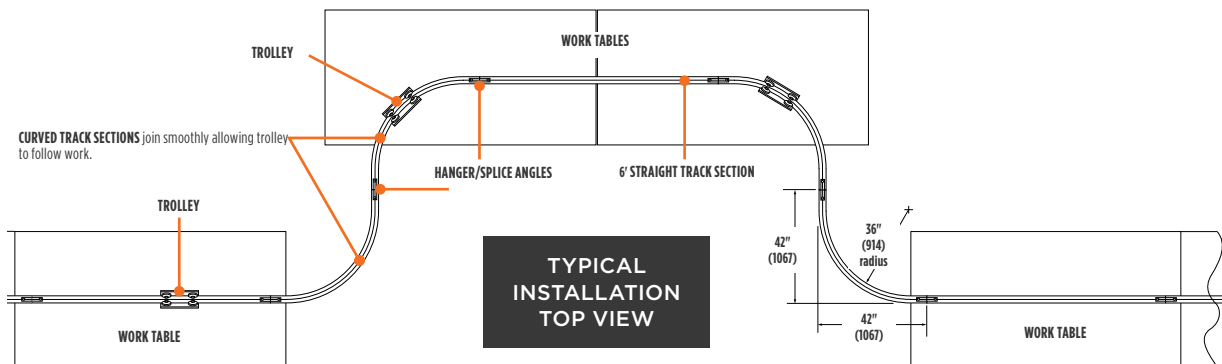
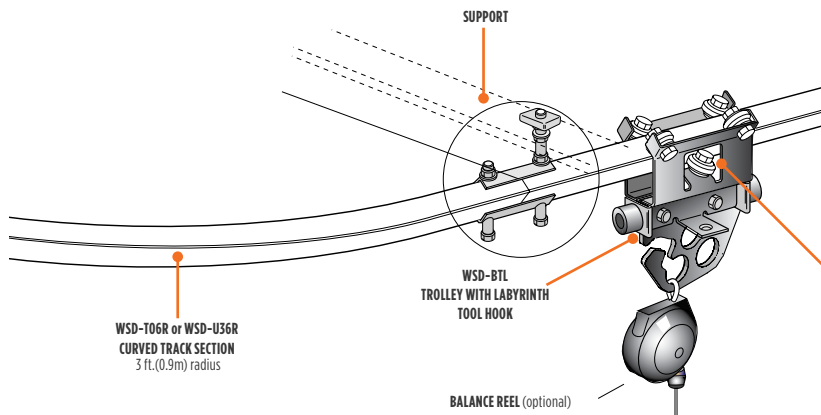

Curved Rail follows the work *continued*

Guide tools and controls around corners

COMPONENT CHART		
DESCRIPTION	FINISH	MODEL NO.
6' (1.8m) STRAIGHT TRACK SECTION	BEIGE POLYESTER	WSD-T06
	UNFINISHED	WSD-U06
90" x 36" (914 mm) RADIUS CURVED TRACK SECTION	BEIGE POLYESTER	WSD-T36R
	UNFINISHED	WSD-U36R
SPLICE ANGLE KIT includes (2) angles, hanger bolt, splice bolt, nuts & washers	ZINC PLATED	WSD-SA
END STOP KIT (right, top) includes end stop, hanger bolt, nuts & washers	ZINC PLATED	WSD-ES
TROLLEY-LABYRINTH TOOL HOOK	BLACK POLYESTER	WSD-BTL
FESTOON TRAILER TROLLEY*	BLACK POLYESTER	WSD-RC12

*FESTOON TRAILER TROLLEY (right, bottom) provides easy management of cord or hose supplying power to tool. Fits cable or hose 0.60-0.94" (15-24mm) diameter. Tow cable connecting tool trolley to trailer trolley should not exceed 24" in length.

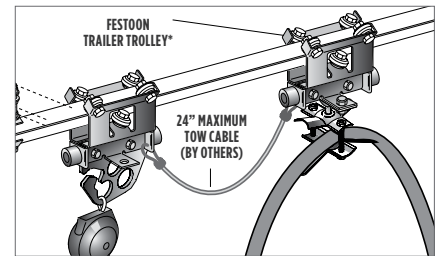
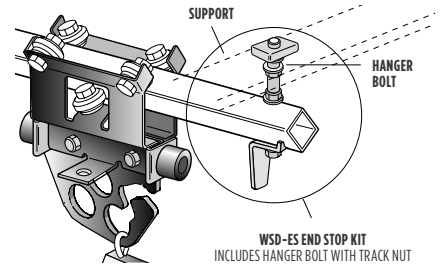

4ft LED Workbench Light & Power Bars

The economic and efficient solution for workbench lighting



DESCRIPTION	MODEL NUMBER	LUMENS	WATTS	LPW
4 Ft Wrap light, 4,000 Lumen LED, 3500K (assembly required)	WBL-204LED	4584	36.9	124

WORK LIGHTS FEATURE:

- Standard Clear Prismatic Lens
- Polycarbonate safety tubes protect lamps, increase safety and meet OSHA, FDA, NEC and USDA requirements preventing contamination in case of lamp breakage
- Model WBL-204A tilts $\pm 15^\circ$ and adjusts to bench width
- Blacked-out side lens minimizes stray light

STANDARDS, CERTIFICATION, COMPLIANCE

All luminaires are built to UL1598 standards and bear appropriate UL labels. Damp location label standard. DLC (Design Lights Consortium) Qualified. Please refer to the DLC website for specific product qualifications at www.designlights.org.

WARRANTY

One year warranty. Terms and conditions apply.

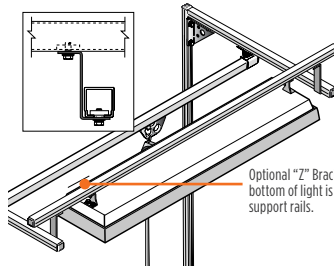

Optional "Z" Brackets raise light so that bottom of light is flush with under side of support rails.

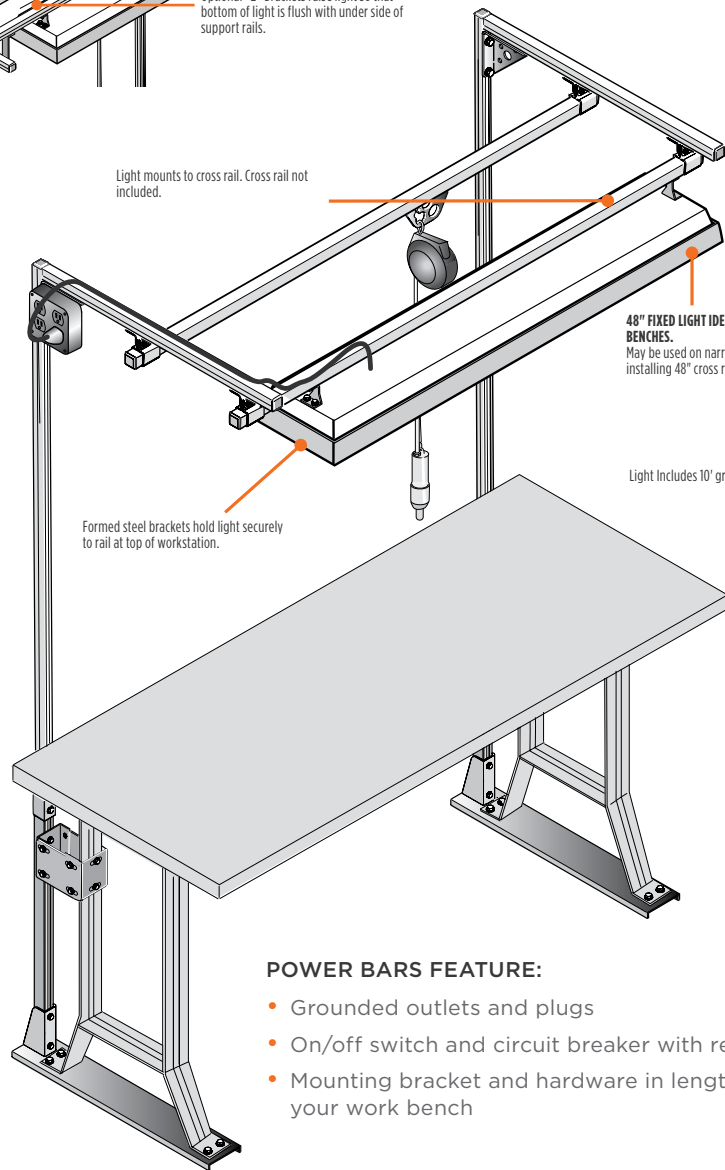

Light mounts to cross rail. Cross rail not included.

48" FIXED LIGHT IDEAL FOR 4' OR WIDER BENCHES. May be used on narrower benches by installing 48" cross rail.

Light Includes 10' grounded cord.

Formed steel brackets hold light securely to rail at top of workstation.

POWER BARS FEATURE:

- Grounded outlets and plugs
- On/off switch and circuit breaker with reset
- Mounting bracket and hardware in length to fit your work bench

4 Ft LED Workbench Light & Power Bars *continued*

The economic and efficient solution for workbench lighting

DESCRIPTION	MODEL NUMBER	FC* @ 3'	FC* @ 4'
48" Two Tube Adjustable Workstation Light	WBL-204A	93	70
48" Four Tube Fixed Workstation Light	WBL-404	185	130
"Z" Bracket to raise light flush with supports	WBL-40X-AM	N/A	N/A
36" Power Bar with 36" Mounting Bar	WPB-303A	N/A	N/A
36" Power Bar with 48" Mounting Bar	WPB-304A	N/A	N/A
36" Power Bar with 60" Mounting Bar	WPB-305A	N/A	N/A
36" Power Bar with 72" Mounting Bar	WPB-306A	N/A	N/A
60" Power Bar with 60" Mounting Bar	WPB-505A	N/A	N/A
60" Power Bar with 72" Mounting Bar	WPB-506A	N/A	N/A

* One foot-candle is equal to one lumen per square foot.

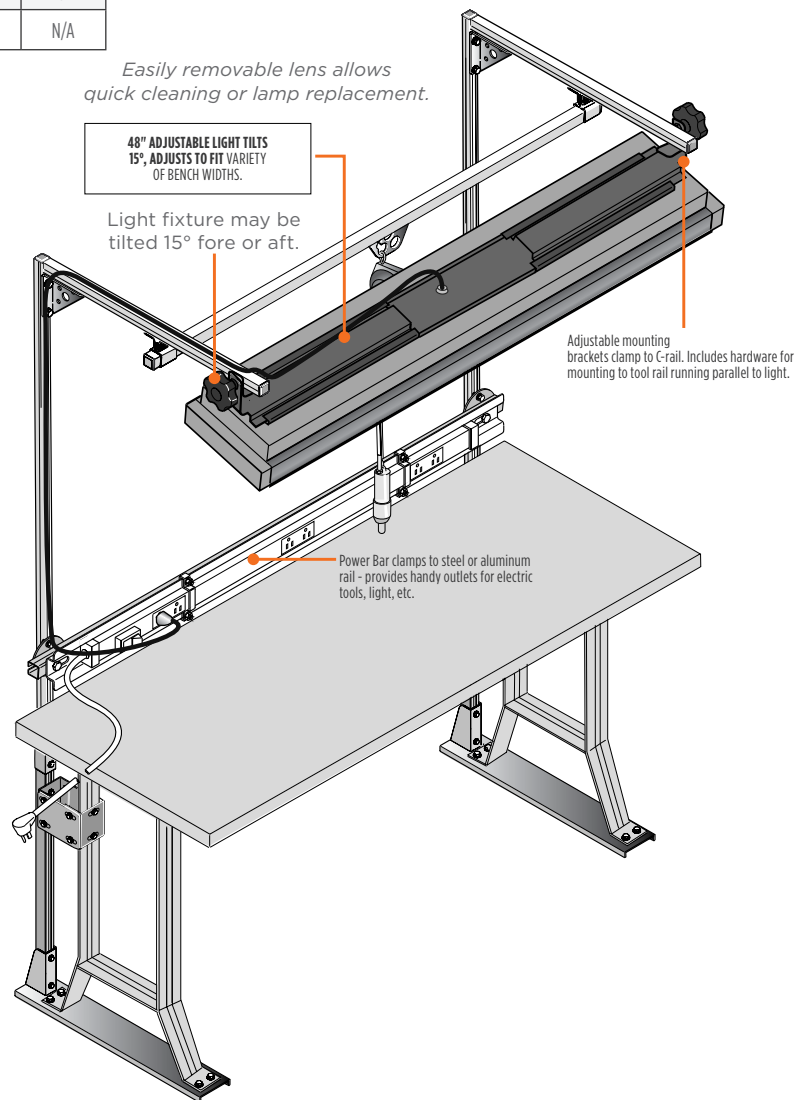

Accessorize your kit

Make your workstations even more productive

MANIFOLD WITH BRACKETS

NEW DESIGN

Square tubing provides 66% more volume than former round tube. Ideal where multiple tools are used. Drilled and tapped for 3/8" NPT air inlets and outlets (see chart below for quantity). Mounts to vertical columns or top rails on workstations. Beige Polyester Finish. Mounting hardware included.



WIDTH ft. (m)	No. TAPS	SHIPPING WEIGHT	MODEL NUMBER
3.0 (0.9)	3	18 lbs.	WMAN-03C
4.0 (1.2)	4	22 lbs.	WMAN-04C
5.0 (1.5)	5	28 lbs.	WMAN-05C
6.0 (1.8)	6	33 lbs.	WMAN-06C
7.0 (2.1)	7	37 lbs.	WMAN-07C
8.0 (2.4)	8	42 lbs.	WMAN-08C

BIN BAR WITH BRACKETS

Holds hanging plastic bins. Mounts to WS50 or WA50 vertical columns. Beige Polyester Finish. Includes mounting brackets and hardware. Accepts Akro, Lewis, Nestier, Duralene and other brands of bin boxes. Maximum capacity 50 lbs. (22.5kg).

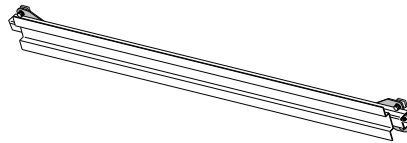

WIDTH ft. (m)	MODEL NUMBER
3.0 (0.9)	WS50-BB03A
4.0 (1.2)	WS50-BB04A
5.0 (1.5)	WS50-BB05A
6.0 (1.8)	WS50-BB06A
7.0 (2.1)	WS50-BB07A
8.0 (2.4)	WS50-BB08A
9.0 (2.7)	WS50-BB09A

SHELVES WITH BRACKETS

Hold up to 50 lbs. (22.5 kg). of parts, tools, etc. Adjustable tilt. Style "A", in 12" or 18" depth, mounts between vertical columns (column spacing fixed). Style "B" (12" deep only) mounts on front of columns (brackets may be adjusted to match column spacing). Polyester Finish. Shelves beige, brackets black. Mounting hardware included.

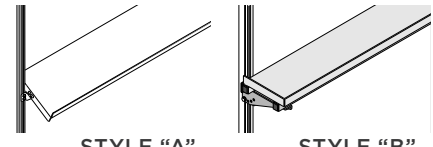

WIDTH* in (mm)	MODEL NUMBER
Style "A"-12"(305) Deep	
Bracket Kit	WS50-SS00
30.0 (762)	WS50-SS03
42.0 (1067)	WS50-SS04
54.0 (1372)	WS50-SS05
66.0 (1676)	WS50-SS06
Style "A"-18"(457) Deep	
Bracket Kit	WS50-SS00
30.0 (762)	WS50-SS183
42.0 (1067)	WS50-SS184
54.0 (1372)	WS50-SS185
66.0 (1676)	WS50-SS186

*Center-to-center spacing of vertical columns must be WIDTH + 2" (51mm) for Style "A" shelves.

WIDTH* in (mm)	MODEL NUMBER
Style "B"-12"(305) Deep	
Bracket Kit	WS50-SS00A
32.0 (812)	WS50-SS03A
44.0 (1117)	WS50-SS04A
56.0 (1422)	WS50-SS05A
68.0 (1727)	WS50-SS06A

Adjustable Foot Rest

Easy on the legs

Seated or standing, your workers can be more productive and more comfortable when a foot rest is used. In addition, use of a foot rest offers a degree of protection from back or leg strain. Fully adjustable and strong enough for heavy industrial applications, it's constructed of steel with extruded aluminum foot bar. Standard model measures 29" wide, 12.75" deep and 12.25" high. Smaller "under desk" version measures is 23" wide. Both rest on four non-skid rubber feet. The foot bar is easily adjustable from 4" to 11" above the floor and tilts 15° fore and aft. Frame is finished with matte black baked polyester coating. Foot bar is natural aluminum with two anti-skid strips.

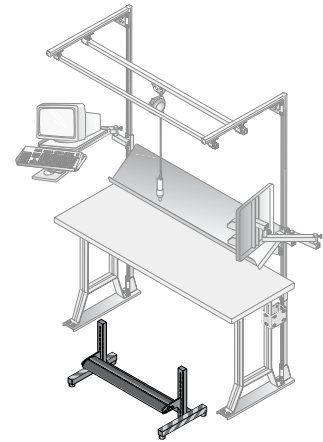

DESCRIPTION	MODEL NUMBER
Standard Adjustable Foot Rest	HWS-FR01
Office "Under Desk" Foot Rest	HWS-FR02

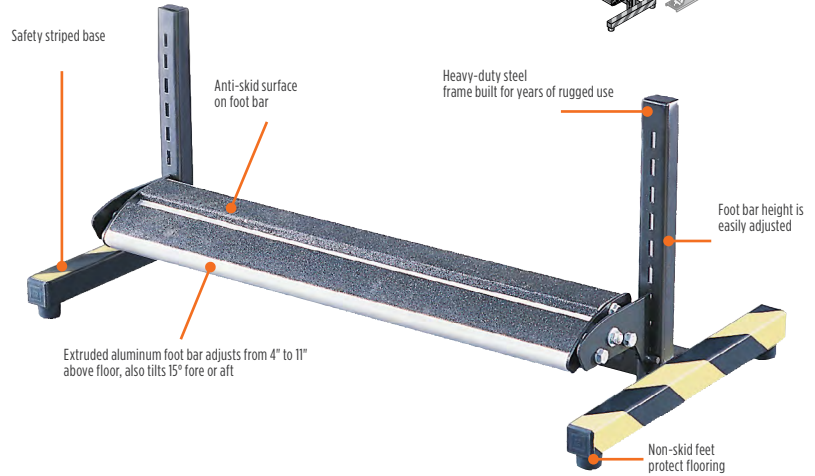

Air Lines

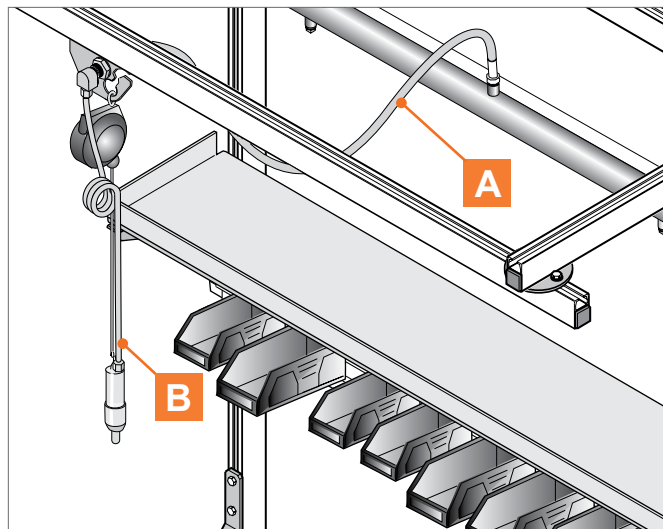

A The most flexible air line we have found. Ideal for connecting tool trolley to manifold or other supply because its flexibility does not interfere with trolley movement. Clear, reinforced plastic, 3/8" I.D. with 3/8" NPT male swivel fittings on both ends.

B Coiled hose from trolley to tool. Transparent blue polyurethane hose is flexible and light weight, doesn't interfere with tool positioning. Excellent memory retention. High chemical resistance. 3/8" O.D. x 1/4" I.D. x 4' extended length. 1/4" NPT male swivel fitting both ends.

LENGTH ft. (m)	MODEL NUMBER
2.0 (0.6)	HWS-AL02
3.0 (0.9)	HWS-AL03
4.0 (1.2)	HWS-AL04
5.0 (1.5)	HWS-AL05
6.0 (1.8)	HWS-AL06

MODEL NUMBER
HWS-AC04

Swing Arms

Make your workplace user-friendly

Add swing arms and attachments to existing workstations or benches. Column mounts clamp on any WS50 or similar column or rail. Bench mount can be bolted to any level surface.

Arms, elbows, and attachments slide together and can be adjusted for less strain and maximum worker efficiency. Black baked polyester finish (boards natural, beige, or white as shown). Max capacity 30 lbs (13.5 kg), arm alone or arm and elbow together. Three or more arms or elbows on one mount reduces capacity and is not recommended. Swing arms, elbows and attachments include adjustable drag brakes. Installation hardware included with column mounts.

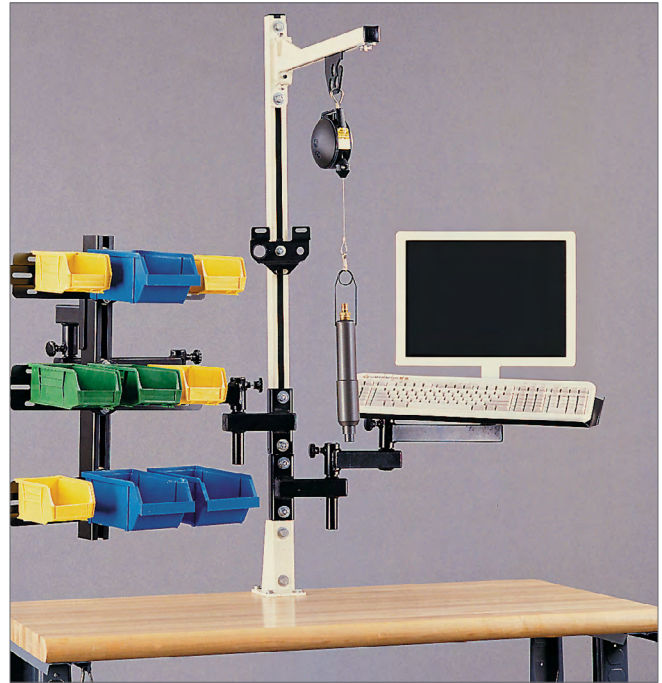

Single Column Kit shown with swing arms. Swing arms may also be used with dual column kits.

Swing Arms

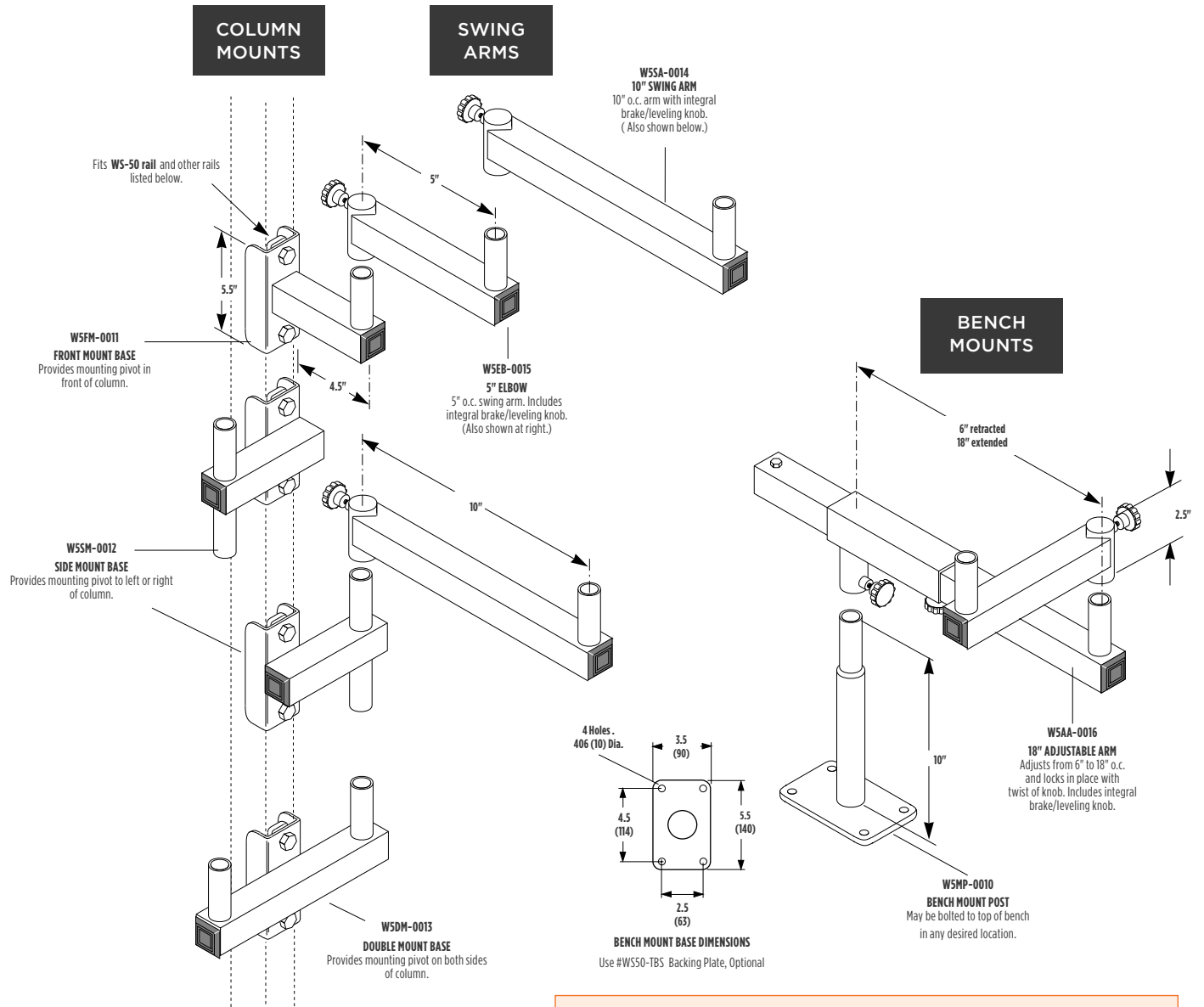

BASES MOUNT TO COLUMNS MADE BY OTHERS

The wrap-around design of the column mounts allows affixing to a variety of commonly used vertical support rails with dimensions similar to our WS50 rail. The rails listed below will accept these mounting bases.

BRAND	RAIL TYPE	BRAND	RAIL TYPE
Aeromotive	See bewa	Econoline	WS50, WA50
Bee-Line ^①	B-22 & B-24	Kindorf ^①	B-905
bewa ^②	5400	Unistrut ^①	P-1000, P-3000
DuctoWire	FC-CH2A	Wampfler ^②	24-100

^①This is a "construction" rail and does not provide a suitable surface for wheels.

^②German product design

Accessorize your kit

Make your workstations even more productive

Customize your workstations to fit the task and the worker. Attachments slide easily onto mounts or swing arms (previous page). Adjustable brake may be tightened to limit free movement. Frame available separately for holding your custom board. Components finished as shown below. All mounting hardware included. Complete kits, including arms, also available. See details below, right.

WSBR-1018 (single bar)

WSBR-2018 (double bar, shown)

WSBR-3018 (triple bar)

BIN RACK

19" w x 20" h (483 x 508).
Heavy gauge steel with black finish.
Accepts Akro, Lewis, Nestler, Duralene
and other brands of bin boxes.

WSBR-0018

BAR ONLY

Includes mounting disk.

WSPB-2018

PEG BOARD & MOUNT

19" w x 20" h (483 x 508).
Natural color composition board.

WSMB-2018

WHITE MARKER BOARD

& MOUNT
19" w x 20" h (483 x 508). Steel.
Use magnets or wipe-off markers.

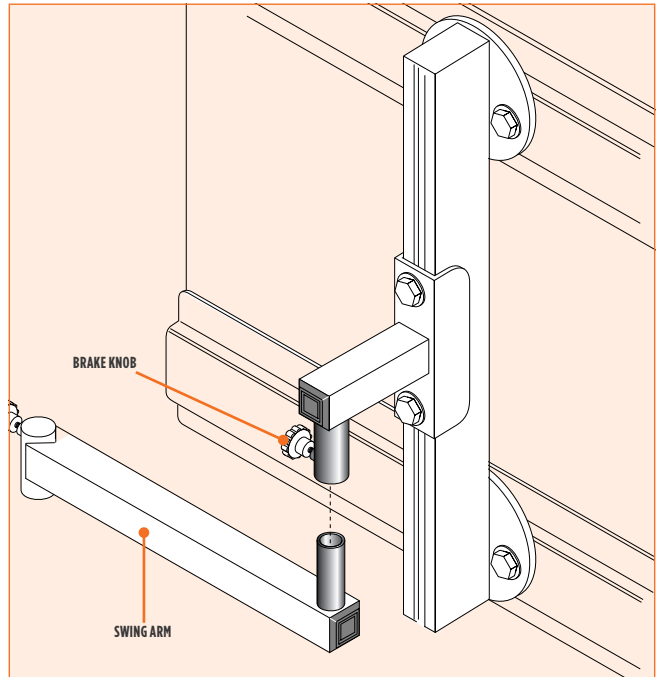
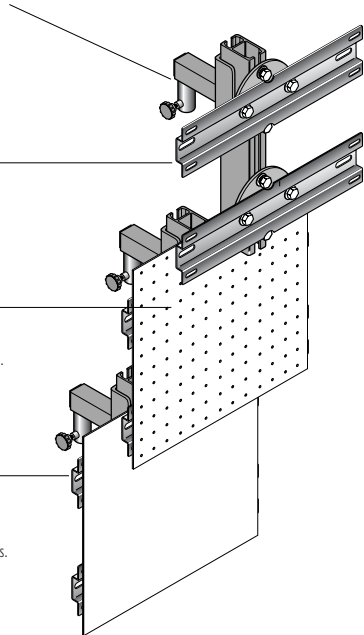

UNIVERSAL MOUNTING SYSTEM

Attachments slide easily onto swing arm or base posts. No tools required. Knob locks attachment in place following adjustment.

Add Accessories to Your Kit *continued*

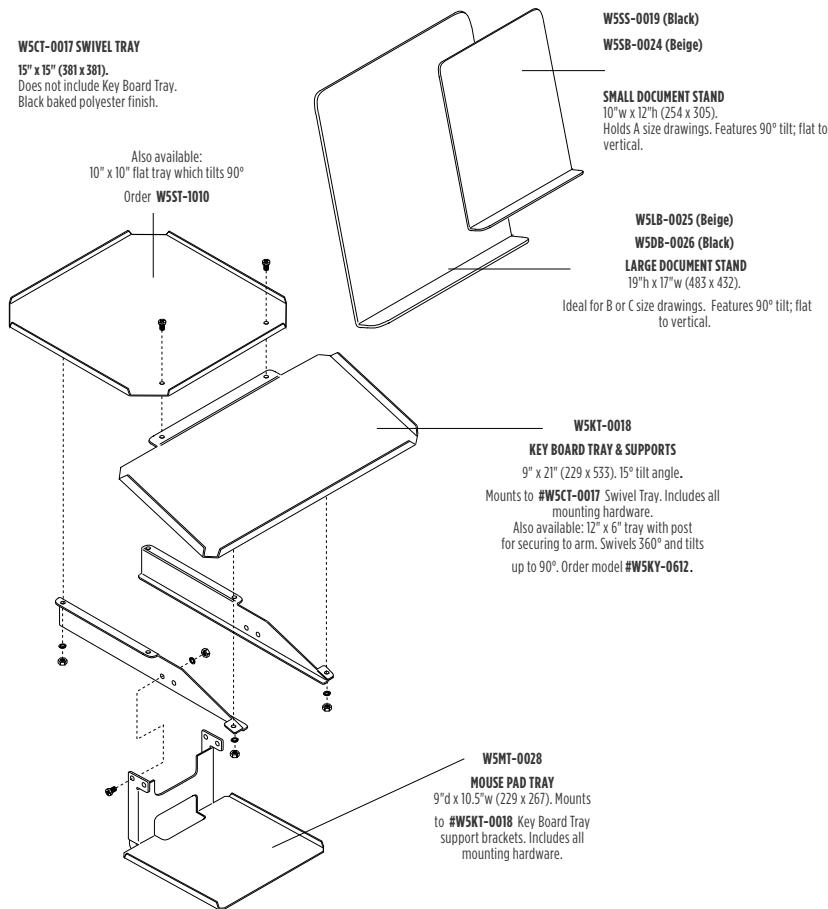

Kits-Include Base, Arms & Attachment

Easily fasten to vertical columns of Workstation. Each kit includes one 5" & one 10" arm plus mounting base and attachment shown. Rugged steel construction. All mounting hardware included.



Document Stand. 19" W x 17" H. 90° tilt, from flat to vertical.



Combo Computer, Keyboard & Mouse Tray. CPU tray 15" x 15"; Keyboard tray 9" x 21", tilts 20°. Mouse tray 9" D x 10.5" W.

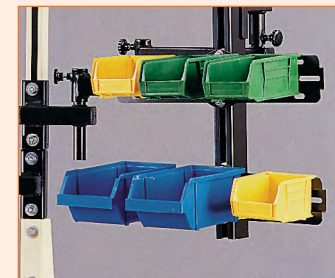

Adjustable, See-thru Rack for Hanging Shelf Bins. 24" H x 18" W. (Accommodates Akro-Mils Akrobins™, as well as Gould Duralux™ bin boxes)

DESCRIPTION	MODEL NUMBER
Document Stand	W5DS-SAK
Adjustable Bin Rack	W5BB-SAK
Combo Computer & Keyboard Tray	W5CK-SAK

TORQ-ARM™ for assembly tools

Complete workstation kit or TORQ-ARM™ only

TORQ-ARM™ torque neutralizing arms for workstations comply with OSHA Ergonomics standards. Light weight anodized aluminum arms support weight of tool and allow easy positioning while preventing transmission of rotational forces to worker's hands or wrists. Units include tool balancer, telescoping positioning arms and rolling trolley for mounting in lateral tool rail on workstation or on bench mounted jib with swing boom (jib included). Available for either electric or air tools. Electric tool models feature secure tool clamp which may also be used for electric or air powered pistol grip tool. Air tool models feature a U-joint manifold which supplies air to tool and allows vertical and horizontal tool positioning.

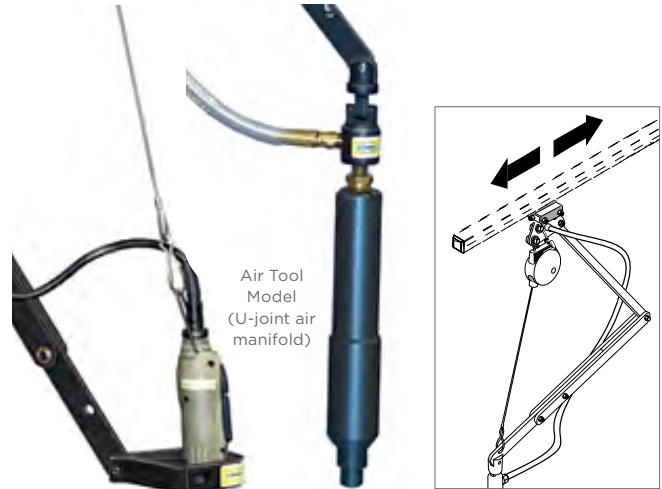

Electric Tool Model
(Tool Clamp
0 1.25 MIN
0 2.00 MAX)

Air Tool Model
(U-joint air manifold)

BOOM MOUNTED TORQ-ARM™ includes 9" (229mm) fixed arm, 18"-25" (457-635mm) telescoping arm, tool balancer, mounting trolley, and all related hardware. Air tool models include U-joint manifold and air line with fittings. Electric tool models include tool clamp. Boom not included. See chart below.

TORQ-ARM™ ONLY-BOOM MOUNTED				
Min. - Max. TOOL WEIGHT	TOOL TYPE	UNIT WEIGHT	MODEL NUMBER	
			WS30 BOOM	WS50 BOOM
0.5-1.5 lbs. (0.2-0.7 kg)	Air	5 lbs. (2.25 kg)	WS30-FA-1	WS50-FA-1
1.5-3.0 lbs. (0.7-1.4 kg)	Air	5 lbs. (2.25 kg)	WS30-FA-2	WS50-FA-2
3.0-5.0 lbs. (1.4-2.3 kg)	Air	5 lbs. (2.25 kg)	WS30-FA-5	WS50-FA-5
0.5-1.5 lbs. (0.2-0.7 kg)	Electric	5 lbs. (2.25 kg)	WS30-FE-1	WS50-FE-1
1.5-3.0 lbs. (0.7-1.4 kg)	Electric	5 lbs. (2.25 kg)	WS30-FE-2	WS50-FE-2
3.0-5.0 lbs. (1.4-2.3 kg)	Electric	5 lbs. (2.25 kg)	WS30-FE-5	WS50-FE-5

TORQ-ARM™ for assembly tools *continued*

Complete workstation kit or TORQ-ARM™ only

JIB MOUNTED TORQ-ARM™ KIT includes all parts needed to assemble a complete, ergonomically correct TORQ-ARM™ on an existing bench. Maximum torque rating is 15 ft/lbs (20N.m). All steel parts protected with durable baked polyester finish. Order model for correct type and weight tool. Tools not included.

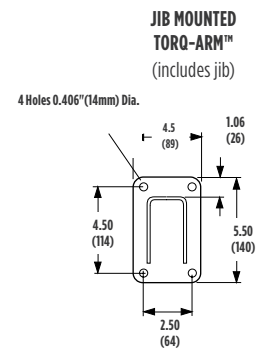

WS50-TB MOUNTING BASE DIMENSIONS
#WS50-TBS Backing Plate Optional.
Recommended on wood or composite tops.

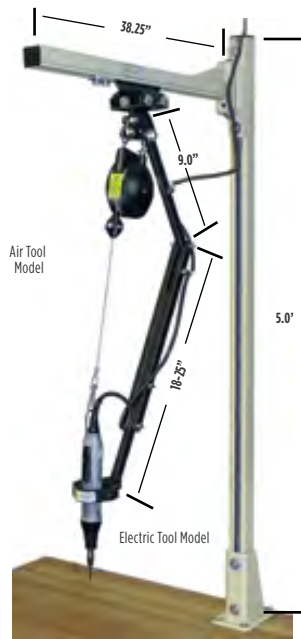

TORQ-ARM™ MOUNTED ON JIB WITH SWING BOOM. MOUNTS TO BENCH TOP. JIB INCLUDED.			
Min. - Max. TOOL WEIGHT	TOOL TYPE	UNIT WEIGHT	MODEL NUMBER
0.5-1.5 lbs. (0.2-0.7 kg)	Air	20 lbs. (9 kg)	WS30-RA-1
1.0-2.50 lbs. (0.5-1.1 kg)	Air	20 lbs. (9 kg)	WS30-RA-2
2.0-5.0 lbs. (0.9-2.3 kg)	Air	20 lbs. (9 kg)	WS30-RA-5
0.5-1.5 lbs. (0.2-0.7 kg)	Electric	20 lbs. (9 kg)	WS30-RE-1
1.0-2.50 lbs. (0.5-1.1 kg)	Electric	20 lbs. (9 kg)	WS30-RE-2
2.0-5.0 lbs. (0.9-2.3 kg)	Electric	20 lbs. (9 kg)	WS30-RE-5

BENCH MOUNTED TORQ-ARM™ JIB includes (1) WS30 swing boom, (1) WS50 vertical column with base, (2) end caps, (1) end stop, hardware for mounting boom to column and column to base, and (1) TORQ-ARM™ kit including 9" (229mm) fixed arm, 18"-25" (457-635mm) telescoping arm, tool balancer, mounting trolley, and all related hardware. Air tool models include U-joint manifold and air line with fittings. Electric tool models include tool clamp.

TORQ-ARM for assembly tools *continued*

RAIL MOUNTED TORQ-ARM™

Rail Not Included

Designed to be mounted on straight overhead tool rails. Specify WS30 or WS50 rail. See chart below.

OVERHEAD RAIL MOUNTED TORQ-ARM™ includes 9" (229mm) fixed arm, 18"-25" (457-635mm) telescoping arm, tool balancer, mounting trolley for WS30 or WS50 straight rail (check rail size before ordering), and all related hardware. Air tool models include U-joint manifold and air line with fittings. Electric tool models include tool clamp. Mounting rail and tool not included.

TORQ-ARM™ ONLY-RAIL MOUNTED					
Min. - Max. TOOL WEIGHT	TOOL TYPE	UNIT WEIGHT	MODEL NUMBER		
			WS30 RAIL	WS50 RAIL	
0.5-1.5 lbs. (0.2-0.7 kg)	Air	5 lbs. (2.25 kg)	WS30-TA-1	WS50-TA-1	
1.5-3.0 lbs. (0.7-1.4 kg)	Air	5 lbs. (2.25 kg)	WS30-TA-2	WS50-TA-2	
3.0-5.0 lbs. (1.4-2.3 kg)	Air	5 lbs. (2.25 kg)	WS30-TA-5	WS50-TA-5	
0.5-1.5 lbs. (0.2-0.7 kg)	Electric	5 lbs. (2.25 kg)	WS30-TE-1	WS50-TE-1	
1.5-3.0 lbs. (0.7-1.4 kg)	Electric	5 lbs. (2.25 kg)	WS30-TE-2	WS50-TE-2	
3.0-5.0 lbs. (1.4-2.3 kg)	Electric	5 lbs. (2.25 kg)	WS30-TE-5	WS50-TE-5	



Tool Positioners

Neutralize torque, eliminate tool lifting

TOOL POSITIONERS stop shock and torque transmission to wrists and arms, a major cause of musculo-skeletal disorders (MSDs). Dual parallel arms also keep tool in a vertical position as it is moved across work area, eliminating need for lifting or twisting. Spring tension is adjustable for tools from 1.0-7.0 pounds. Air tools (AM models) attach directly to bottom of air manifold. Electric tools (EC models) clamp to adapter plate. Choice of positioner mounting. Post models mount to top of work surface, positioner is adjustable on 26" post (included). Column mounted positioners include adjustable bracket for attaching to workstation upright. Maximum torque rating is 97 in/lbs (11N.m).

- Reduces transmission of shock and torque to worker's hand, wrist, or arm
- Automatically positions tool perpendicular to work piece
- Adjustable tension supports air or electric powered tools from 1.0-7.0 lbs.
- Arm reach: 15" minimum - 31.5" maximum from base pivot point

Min. - Max. TOOL WEIGHT	TOOL TYPE	MOUNTING TYPE	UNIT WEIGHT	MODEL NUMBER
1.0 - 7.0 lbs. (0.45-3.15 kg)	Air	Post (post included)	5 lbs. (2.25 kg)	WSP-AM
1.0 - 7.0 lbs. (0.45-3.15 kg)	Air	Bracket (bracket included)	5 lbs. (2.25 kg)	WS50-AM
1.0 - 7.0 lbs. (0.45-3.15 kg)	Electric	Post (post included)	5 lbs. (2.25 kg)	WSP-EC
1.0 - 7.0 lbs. (0.45-3.15 kg)	Electric	Bracket (bracket included)	5 lbs. (2.25 kg)	WS50-EC



Tool Positioners *continued*

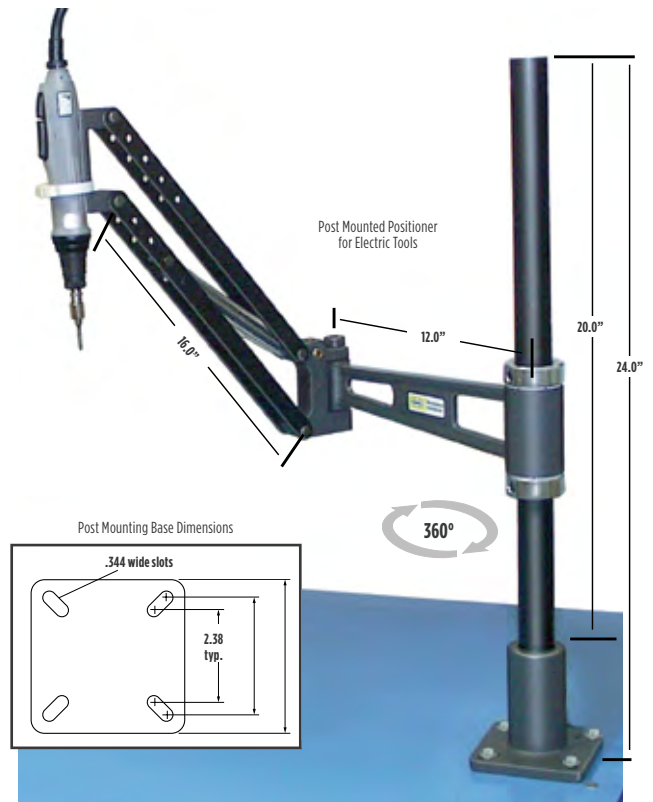

250 lb. Capacity Rail

For heavy-duty applications

RAIL & HANGER KITS

Designed for large air tool balancers, these tool rail kits are similar to our W3F and W5F tool support kits but much heavier. Must be supported every 6 ft. (1.8m) minimum to maintain full rated capacity.

- The basic tool rail is the key component on which all accessories hang
- Maximum 250 lb.(113kg) safe load rating
- Galvanized for maximum corrosion protection
- Available in 6, 12 and 18 ft. (1.8, 3.6, 5.4m) lengths
- May be joined for any length
- Can be mounted on benches, booms, or ceilings

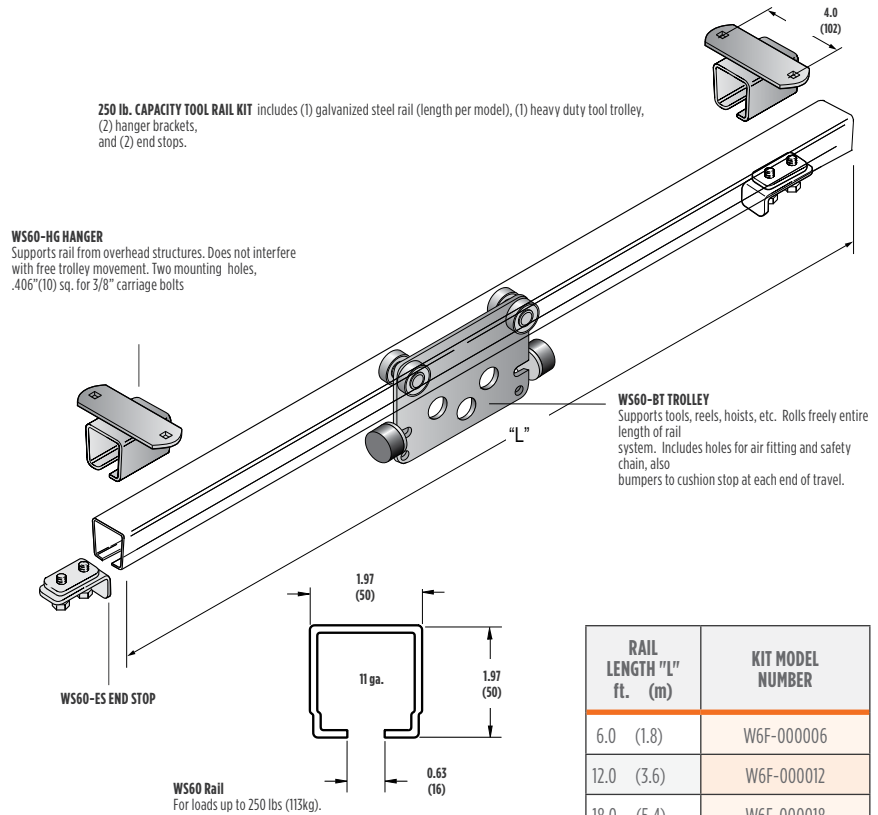

HEAVY-DUTY HANGER

Use components at right to hang Tool Rail from overhead supports

Hanging a tool rail from an overhead structure may be the best way to put a workstation where it's needed. 250 lb. capacity hangers, for use with W560 steel track, are available as individual components on, not as kits. Thru bolts both top and bottom (see photo) act as a safety net. Thru bolts included with the mounting bases. Tool track must be supported every six feet to preserve 250 lb. capacity rating. Vertical C-60 supports must be field-cut to length to support rail at desired height.

DESCRIPTION	MODEL NUMBER
Mounting Base for C-60 Track	WS60-MB
C-60 Hanger Coupler	WS60-HC
Hardware Kit*	WS60-HW

*Hardware Kit includes (4) 1/2 x 1 1/2 bolts, nuts, lock washers and flat washers required to attach hanger coupler to mounting base.

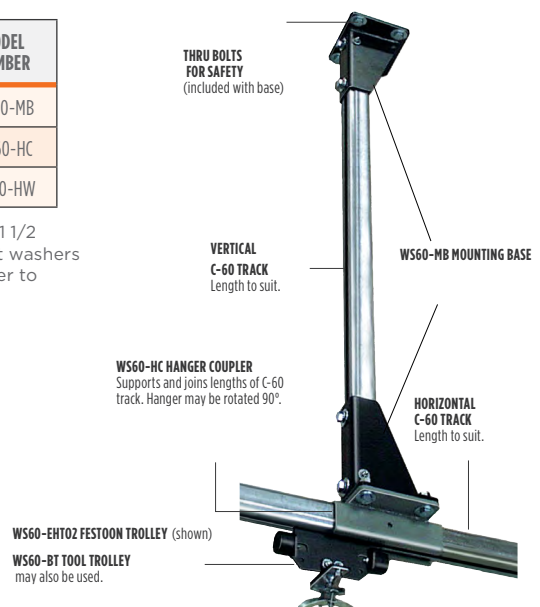

250 lb. Capacity Rail *continued*

COMPONENTS

WS60 TRACK Galvanized
 USE: Horizontal supports, rail for lateral movement of tools, controls, hoists, etc; up to 250 lbs. (113 kg) maximum total load.

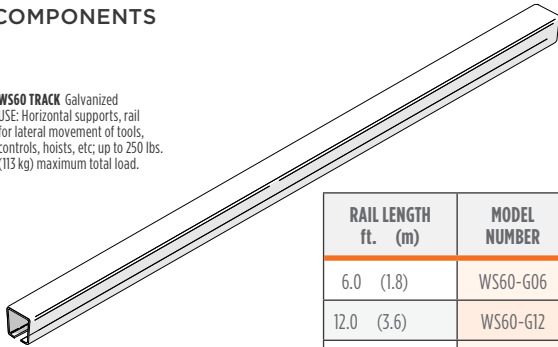

RAIL LENGTH ft. (m)	MODEL NUMBER
6.0 (1.8)	WS60-G06
12.0 (3.6)	WS60-G12
18.0 (5.4)	WS60-G18

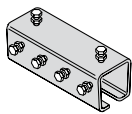

**WS60-CP
 RAIL COUPLER**
 Zinc plated steel.
 USE: Joins track sections.

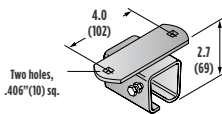

WS60-HG HANGER
 Zinc plated steel.
 USE: Hangs/supports WS60 track from overhead beams, joists, or other structures.



WS60-ES END STOP
 Zinc plated steel.
 USE: Installs in rail to stop trolley

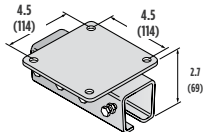

WS60-HC HANGER/COUPLER
 Zinc plated steel.
 USE: Joins track sections.

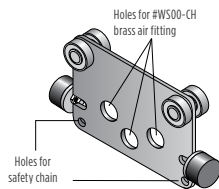

WS60-BT ROLLING TROLLEY
 Black polyester finish. USE: Supports tools, balance reels, torque reels, push button control stations.

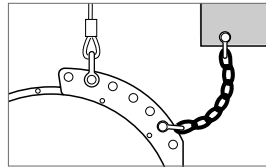

STRONGLY RECOMMENDED

SAFETY CHAIN
 Steel link chain prevents balancer or tool rail from accidental fall. Includes clevis both ends.

RAIL LENGTH ft. (m)	MODEL NUMBER
1.0 (0.3)	SC-BG1
2.0 (0.6)	SC-BG2
3.0 (0.9)	SC-BG3

CABLE/HOSE SIZE TABLE
0.31"–0.59" o.d.....01
0.60"–0.94" o.d.....02
0.95"–1.25" o.d.....03



WS-UB6 U-BOLT ASSEMBLY
 Zinc plated steel
 USE: Secures WS60-MB mounting base or other flat plates to 3" dia. vertical column

FESTOON COMPONENTS

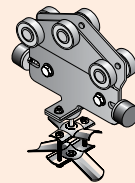

WS60-EHT01 (02, 03) FESTOON TROLLEY
 Black polyester finish. USE: Supports cable or hose in festoon system.

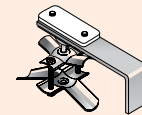

WS60-EC01 (02, 03) END CLIP
 Black polyester finish. USE: Secures cable or hose and acts as end stop in festoon system

Heavy Duty Tool Cranes

50 lb or 250 lb capacity

Rugged bridge crane design allows overhead tool handling for maximum safety with minimal cost. Uses proven components rolling in standard WS-50 or WS-60 (steel) or WA-50 (aluminum) rails. 250 lb capacity unit features doubled tool rail for maximum strength on spans over 6 ft. To speed installation, trolleys, hangers, and tool track bridge are pre-assembled into single units, as is tool rail. Balance reel and tool not included.

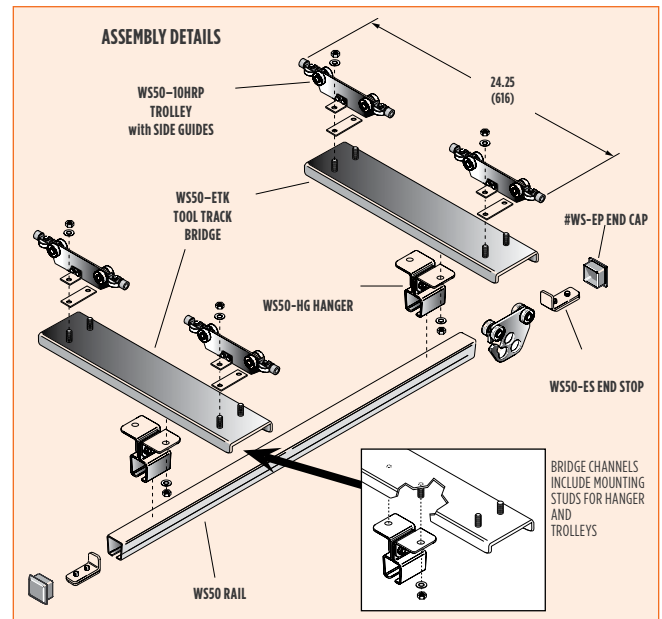
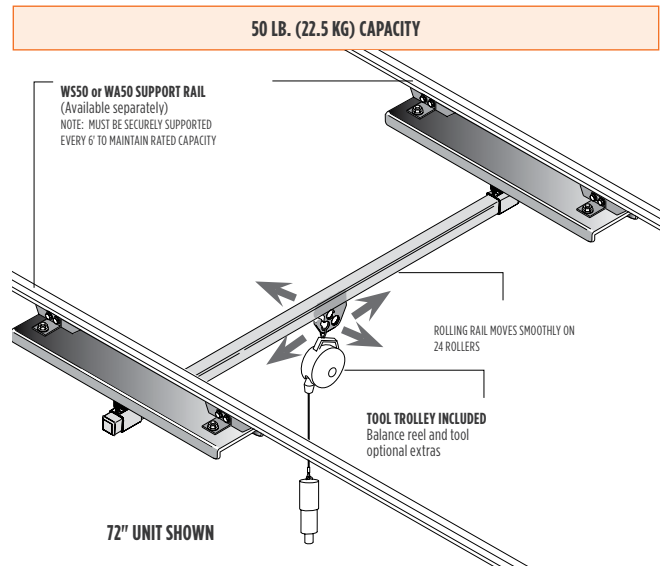

Heavy Duty Tool Cranes *continued*

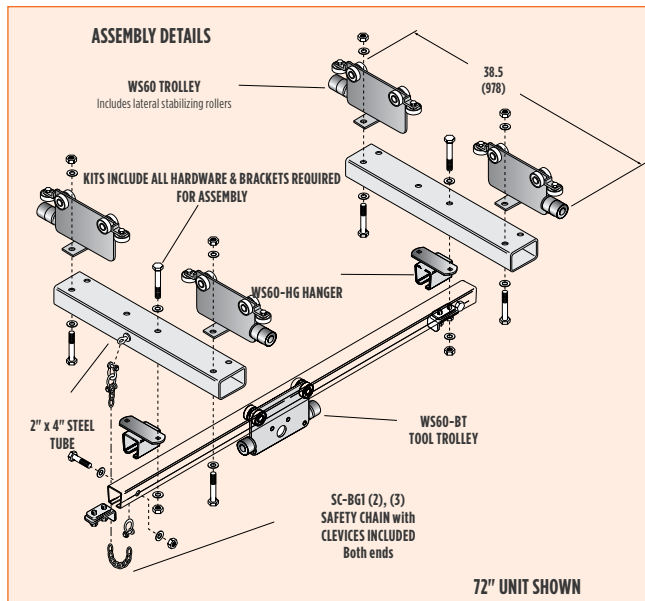
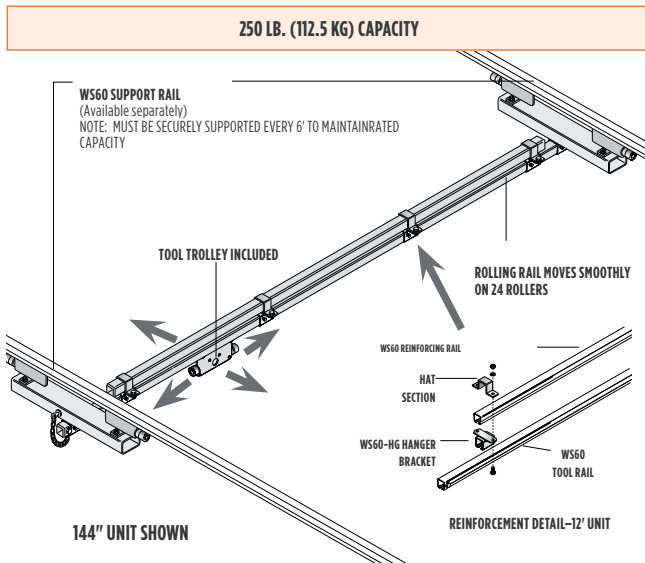

MODEL CHART			
DESCRIPTION	TOOL RAIL in. (mm)	CAPACITY lbs. (kg)	MODEL NUMBER
4 Ft. Overhead Tool Crane	48" (1219)	50 lbs. (22.7 kg)	WS50-ET04
5 Ft. Overhead Tool Crane	60" (1524)	50 lbs. (22.7 kg)	WS50-ET05
6 Ft. Overhead Tool Crane	72" (1829)	50 lbs. (22.7 kg)	WS50-ET06
9 Ft. Overhead Tool Crane	108" (2743)	50 lbs. (22.7 kg)	WS50-ET09
12 Ft. Overhead Tool Crane	144" (3658)	50 lbs. (22.7 kg)	WS50-ET12
6 Ft. Overhead Tool Crane	72" (1829)	250 lbs. (113.6 kg)	WS60-ET06
12 Ft. Overhead Tool Crane	144" (3658)	250 lbs. (113.6 kg)	WS60-ET12

NOTE: For best results, tool rail width should not exceed six times the trolley wheelbase. Example: 24"(2 ft.) x 6 = 12 ft.

Heavy Duty Rolling Rail mounts in two parallel rails, which must be supported every 6' (1.8m) to maintain rated capacity. Recommended distance between support rails is length of tool rail less 12" (305mm). **MAXIMUM RATED CAPACITY OF ROLLING RAIL** includes tool, balancer, and attachments.

50 lb. Capacity Rolling Tool Rail includes (4) WS50-10HRP plain trolleys, (2) WS50-ETK tool track bridges, (2) WS50-HG hanger brackets, (1) WS50-BTL tool trolley, (2) WS-EP end caps, (2) WS50-ES end stops, (1) WS50 tool rail (length per model) and all assembly hardware.

250 lb. Capacity Rolling Tool Rail includes (4) WS60-FT trolleys, (2) 2" x 4" steel tool track bridges, (2) WS60-HG hanger brackets, (1) WS60-BT tool trolley, (2) WS60-ES end stops, (1) WS60 tool rail (length per model), (1) WS60 reinforcing rail (144" unit only), (2) safety chains, assembly brackets and hardware.

Jib Kits

Bench or floor mounted, 30 lb capacity

JIB KITS feature either fixed or swing booms mounted on vertical columns. Adjust the boom higher or lower on the column to suit your specific application.

Vertical columns are typically 4 ft (1.2m) for bench-mounting and 7 ft (2.1m) for floor-mounting. If floor mounted, the optional support clamp (WS50-SC) fastened to wall or back of bench is recommended. Booms are painted beige polyester.

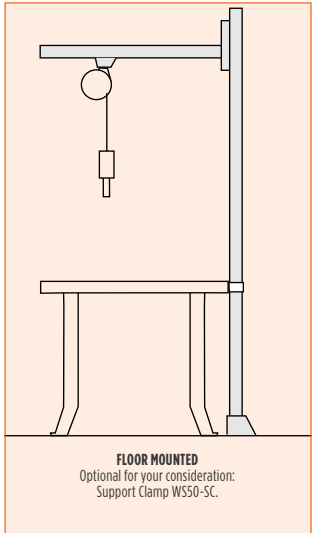
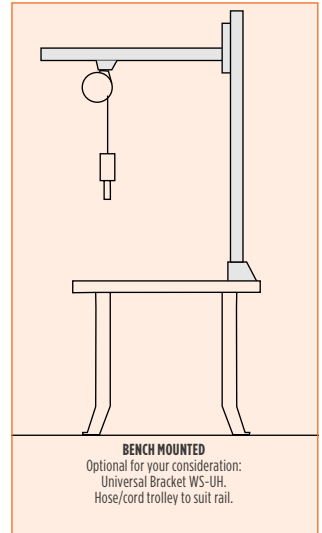

Jib Kits with W3F or W3S prefix include (1) 3' WS30 boom, (1) WS50 vertical column, (1) mounting base, (2) end caps, (1) end stop, (1) balancer trolley (1" hole diameters), and all hardware. Fixed booms are mounted to the vertical columns with angle brackets, also included.

All kits include hardware needed for assembly. Fasteners for mounting base to bench top or floor not included.

Sizes and configurations other than those shown may be assembled by ordering individual components. Refer to other pages in this catalog.

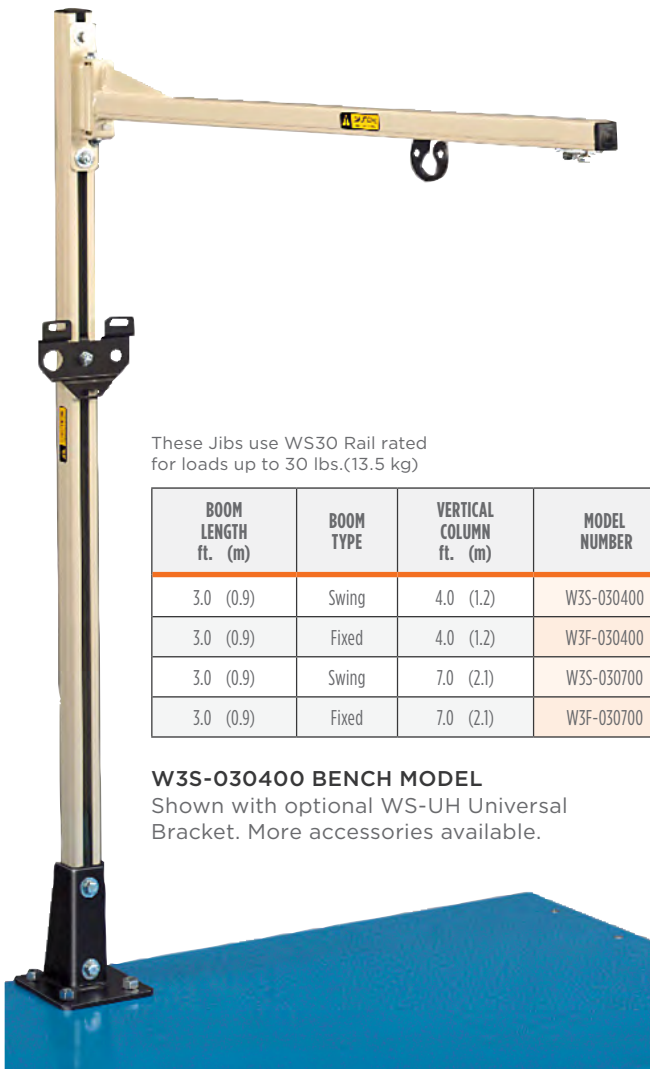

These Jibs use WS30 Rail rated for loads up to 30 lbs.(13.5 kg)

BOOM LENGTH ft. (m)	BOOM TYPE	VERTICAL COLUMN ft. (m)	MODEL NUMBER
3.0 (0.9)	Swing	4.0 (1.2)	W3S-030400
3.0 (0.9)	Fixed	4.0 (1.2)	W3F-030400
3.0 (0.9)	Swing	7.0 (2.1)	W3S-030700
3.0 (0.9)	Fixed	7.0 (2.1)	W3F-030700

W3S-030400 BENCH MODEL

Shown with optional WS-UH Universal Bracket. More accessories available.

Jib Kits *continued*

W3S-030400 BENCH MODEL (shown)
 3ft. (0.9m) swing boom on 4ft. (1.2m) vertical column. For fixed boom use **W3F-030400**

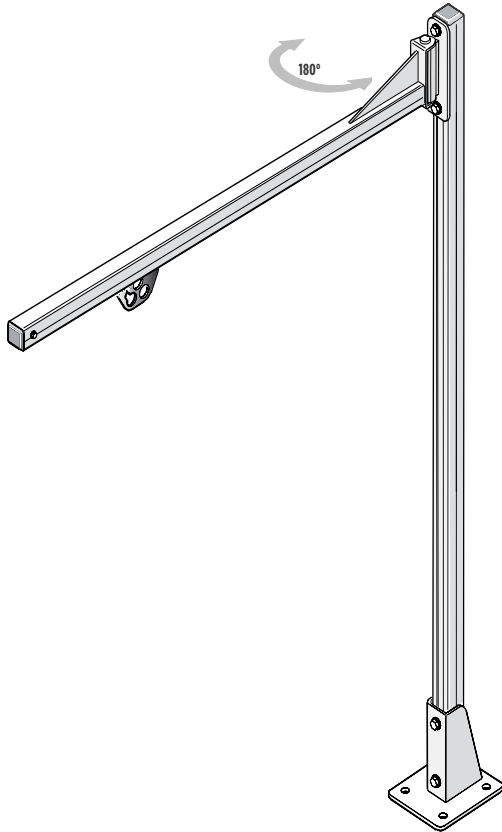

W3S-030700 FLOOR MODEL (shown)
 3ft. (0.9m) swing boom on 7ft. (2.1m) vertical column. For fixed boom, use **W3F-030700**

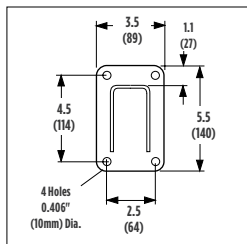
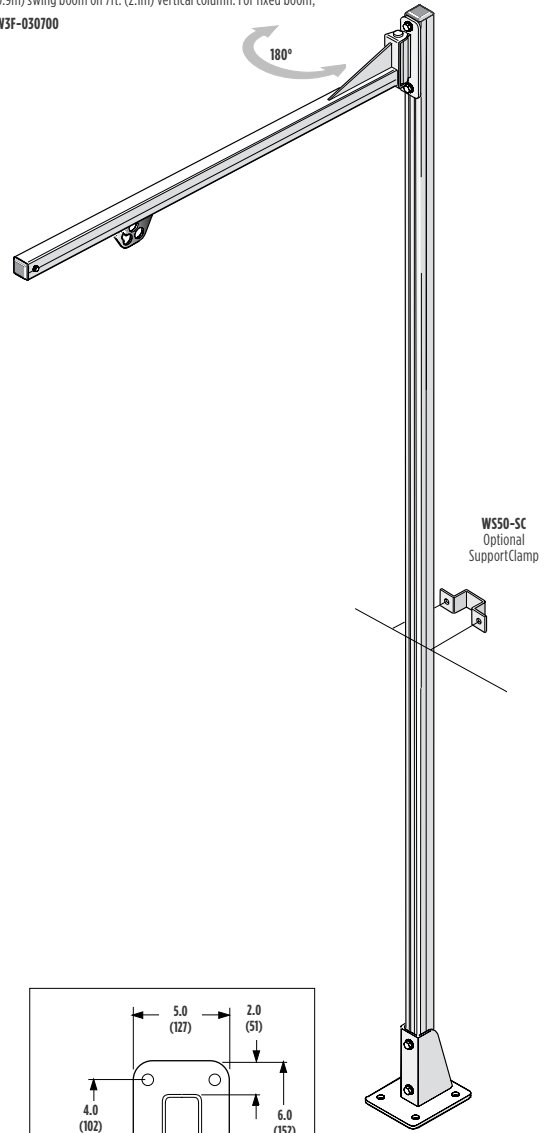

W550-TB
MOUNTING BASE INCLUDED
 Use Optional W550-TBS Backing Plate

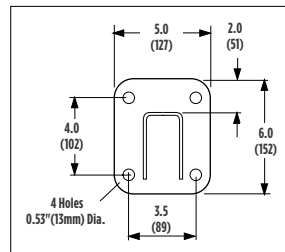

W550-MB
MOUNTING BASE INCLUDED
 Use Optional W550-MBS Backing Plate

Jib Kits

Floor mounted, 50 lb capacity, 6' - 18' booms

JIB KITS feature heavy duty I-beam booms or C-rail booms. Kits with 50 lb. capacity are available with either fixed or swing (180°) booms up to 18' long. Painted beige polyester. Columns available to 12 ft high. Booms may be mounted higher or lower on the column to suit your specific application. Booms are WS50 rail for loads up to 50 lbs (22.5kg). Vertical columns include pre-drilled, gusseted mounting bases. The Vertical columns are 3" O.D. x 2.5" I.D. (76mm x 64mm) welded steel tubing. Vertical column for 18' boom is 6" square steel tube with 3" dia. x 2' mounting shaft at top. Vertical columns for 50 lb capacity jibs also available separately, see model chart.

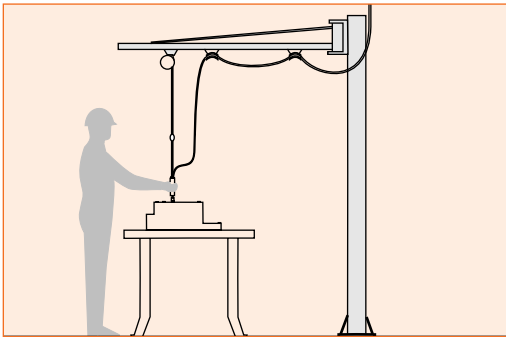

Jib Kits include (1) boom, (1) vertical column with integral mounting base (1) balancer trolley, (1) Hose/Cable Trolley, (1) End Clip, and all assembly hardware.

Kit Numbers assume festoon trolleys for typical 3/8" (9mm) I.D. hose with saddle to handle O.D. range of 0.60"-0.94" (15-24mm). If optional saddle with range of 0.31"- 0.59" (08-15mm) is desired, substitute "1" for "2" as last digit of model number. Example: W5S-060301

MODEL CHART-HEAVY DUTY JIBS						
BOOM LENGTH ft. (m)	BOOM TYPE	VERTICAL COLUMN ft. (m) TYPE	BASE TYPE	WGT lbs.	MODEL NUMBER	
6.0 (1.8)	Fixed	3.0 (0.9) Round	W5	53	W5F-060302	
6.0 (1.8)	Swing	3.0 (0.9) Round	W5	53	W5S-060302	
10.0 (3.0)	Fixed	3.0 (0.9) Round	W5	81	W5F-100302	
10.0 (3.0)	Swing	3.0 (0.9) Round	W5	81	W5S-100302	
6.0 (1.8)	Fixed	7.0 (2.1) Round	W5	83	W5F-060702	
6.0 (1.8)	Swing	7.0 (2.1) Round	W5	83	W5S-060702	
10.0 (3.0)	Fixed	7.0 (2.1) Round	W5	111	W5F-100702	
10.0 (3.0)	Swing	7.0 (2.1) Round	W5	111	W5S-100702	
6.0 (1.8)	Swing	8.0 (2.4) Round	W5	90	W5S-060802	
6.0 (1.8)	Fixed	9.0 (2.7) Round	W5	98	W5F-060902	
6.0 (1.8)	Swing	9.0 (2.7) Round	W5	98	W5S-060902	
10.0 (3.0)	Fixed	9.0 (2.7) Round	W5	126	W5F-100902	
10.0 (3.0)	Swing	9.0 (2.7) Round	W5	126	W5S-100902	
12.0 (3.6)	Swing	9.0 (2.7) Round	W5	138	W5S-120902	
18.0 (5.4)	Swing	12.0 (3.6) **Square	W5S	373	W5S-181202	

STOPS TO LIMIT BOOM SWING

Manual Boom Stop - Model W5S-SK. Spring Loaded Boom Stop - W5S-BMLK - 20" Release Rod & W5S-BMLK54 - 54" Release Rod. Both W5S-BMLKs include spring loaded lock, brackets and all hardware. All field installed only.



Two boom stops are available to provide the flexibility of a swing boom but limiting the swing in one or both directions. One (below) has manually positioned (screw-in) stops that limit swing to 15°, 30°, 45°, or 60° in either direction. The other (left) has a spring-loaded stop. When pulled, it allows the boom to swing freely throughout its normal 180° arc and, when released, lock it at the straight position or every 15° in either direction. Stops are easily installed on 50 lb. capacity swing booms without drilling or welding.



Jib Kits *continued*

Floor mounted, 50 lb capacity, 6' - 18' booms

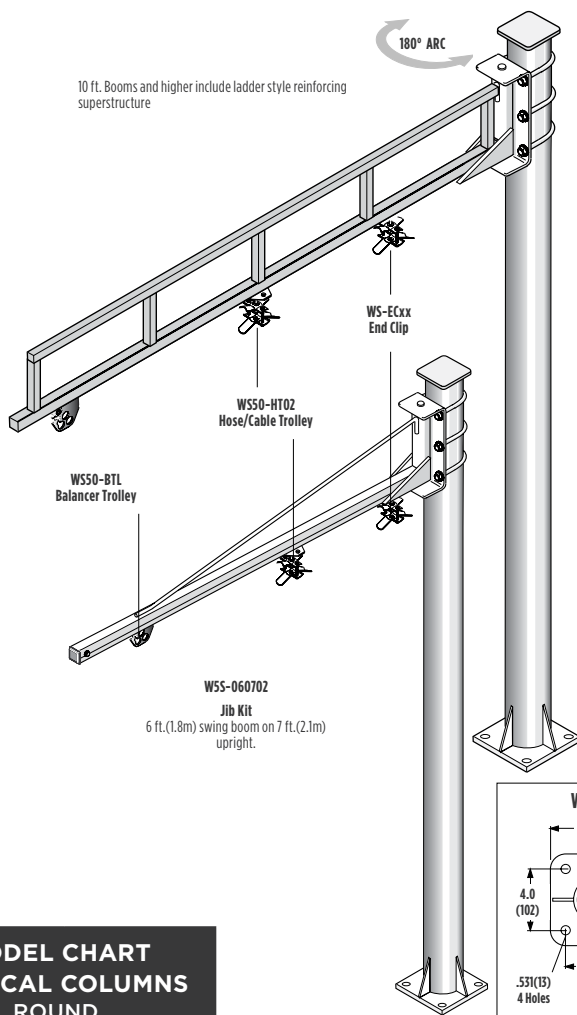

COLUMN ONLY
See Round and Square Model Charts
WS00-VCS12 Shown

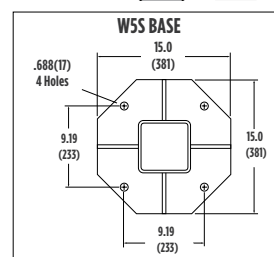
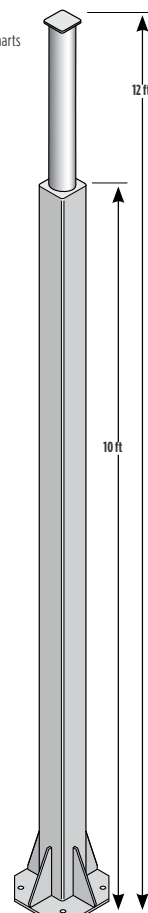

MODEL CHART VERTICAL COLUMNS ROUND	
COLUMN LENGTH ft. (m)	MODEL NUMBER
3.0 (0.9)	WS00-VC03
5.0 (1.5)	WS00-VC05
6.0 (1.8)	WS00-VC06
7.0 (2.1)	WS00-VC07
8.0 (2.4)	WS00-VC08
9.0 (2.7)	WS00-VC09
10.0 (3.0)	WS00-VC10
11.0 (3.3)	WS00-VC11
12.0 (3.6)	WS00-VC12



6' Boom Length Application - Shown with optional Hubbell Balancers over machining work area.

MODEL CHART VERTICAL COLUMNS SQUARE	
COLUMN LENGTH ft. (m)	MODEL NUMBER
12.0 (3.6)	WS00-VCS12

May be used with any 50 lb. capacity boom.

Jib Kits

Floor mounted, 150 lb – 300 lb capacity, 6’ – 10’ booms

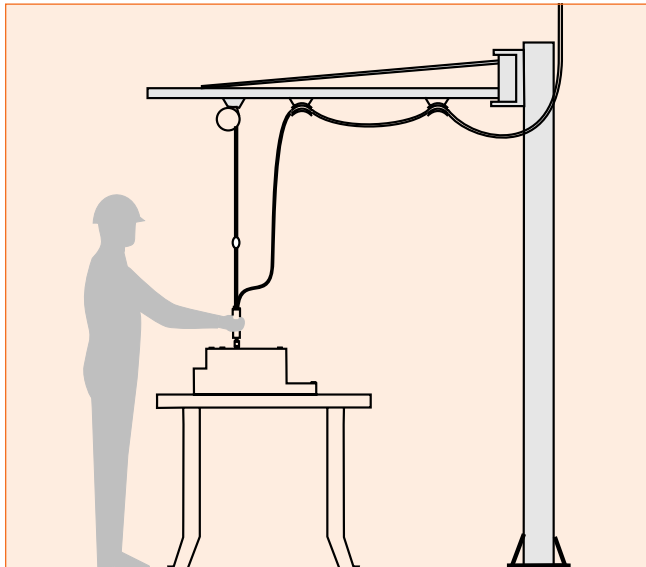

JIB KITS include (1) boom, (1) vertical column with integral mounting base, (1) balancer trolley, (2) festoon trolleys, (1) end clip, and all assembly hardware.

STOPS TO LIMIT BOOM SWING

Boom Stops – 150 lb. & 300 lb. Jibs - Model W6S-SK
Consists of two machined steel stops (one for each direction and all required hardware. All field installed only.

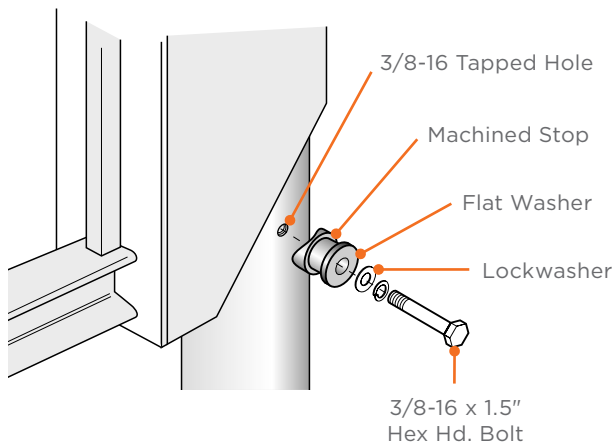

BOOM LENGTH ft. (m)	BOOM TYPE	VERTICAL COLUMN ft. (m)	SHIPPING WEIGHT lbs.	MODEL NUMBER
150 lbs. (67.5kg) capacity Jib. Boom is WS60 rail. Column is 4" schedule 40 steel pipe.				
6.0 (1.8)	360° Swing	10.0 (3.0)	520	W15S-100600
8.0 (2.4)	360° Swing	10.0 (3.0)	535	W15S-100800
10.0 (3.0)	360° Swing	10.0 (3.0)	550	W15S-101000
* Full Rotation Stops			5	W6S-SK
300 lbs. (135kg) capacity Jib. Boom is 3" I-beam. Vertical column is 6" schedule 40 steel pipe.				
10.0 (3.0)	Pneumatic	10.0 (3.0)	640	W6S-101002
10.0 (3.0)	Electric	10.0 (3.0)	668	W6S-101002-430
I-Beam Trolley only - Fits 3"(76) I-beam			18	W6S-BT
* Full Rotation Stops			5	W6S-SK



When less than a full 360° swivel is desired on the 300 lb. capacity jib, add the Model W6S-SK stops.

Swing Stop Kit consists of two machined steel stops (one for each direction) & all required hardware. Stops are RED for visibility.

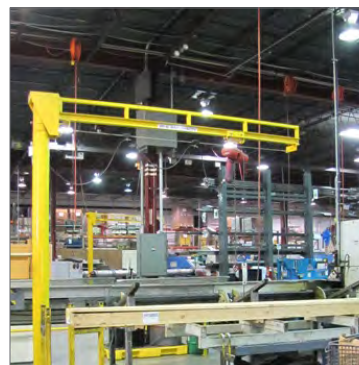

Rotating 300 lb. Jib shown at end of multiple machine lines.

Jib Kits *continued*

Floor mounted, 150 lb. – 300 Lb. capacity, 6' – 10' booms

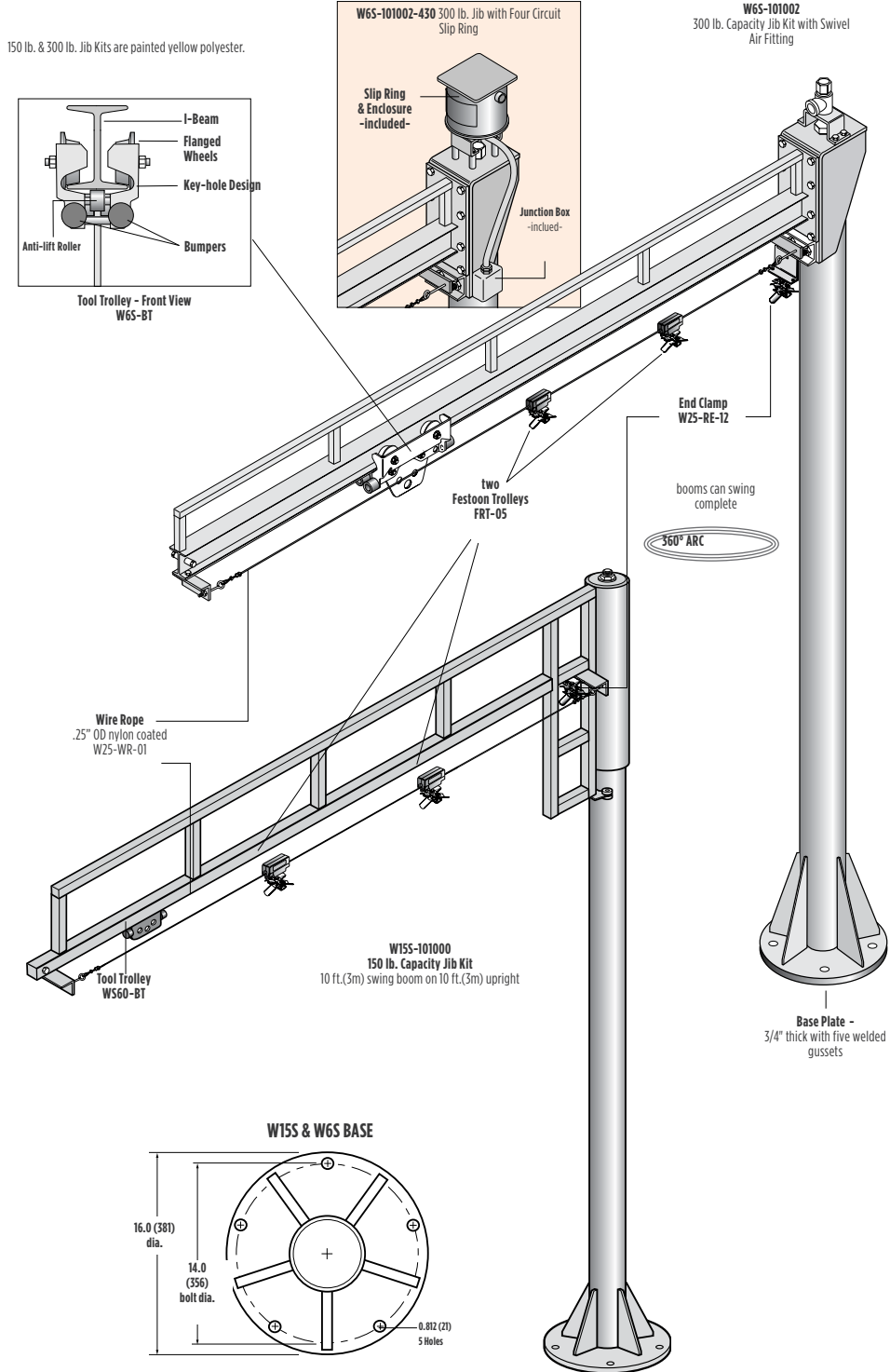

Jib Kits

Ceiling mounted, 50 lb capacity jib kits

Free up floor space for greater plant layout flexibility. Mounting a jib from an overhead structure may be the best way to put a workstation where it's needed. Jibs have steel WS50 booms in length shown. Vertical columns include a heavy duty 3ft. (0.9m) safety chain at the top and safety plate at the bottom to prevent boom from sliding off. The columns are 3"O.D. x 2.5" I.D. (76 x 64mm) welded steel tubing.

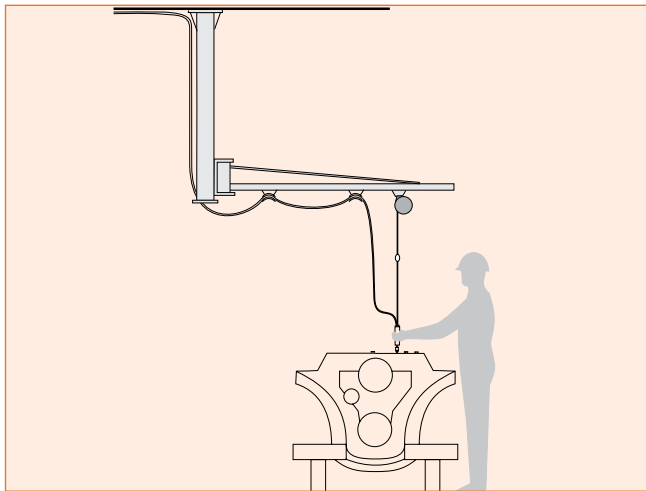

WS50 RAIL BOOMS FOR LOADS UP TO 50 LBS. (22.5KG)				
BOOM LENGTH ft. (m)	BOOM TYPE	VERTICAL COLUMN ft. (m)	MODEL NUMBER w/ BOOM	MODEL NUMBER w/o BOOM
6.0 (1.8)	Swing	3.0 (0.9)	WCS-060302	WS00-CC03
6.0 (1.8)	Swing	5.0 (1.5)	WCS-060502	WS00-CC05
6.0 (1.8)	Swing	6.0 (1.8)	WCS-060602	WS00-CC06
6.0 (1.8)	Swing	7.0 (2.1)	WCS-060702	WS00-CC07
6.0 (1.8)	Swing	8.0 (2.4)	WCS-060802	WS00-CC08
6.0 (1.8)	Swing	9.0 (2.7)	WCS-060902	WS00-CC09

CEILING MOUNTED JIB KIT

Includes 6 ft.(1.8m) swing boom, vertical column with integral safety chain and safety plate, 3 U-bolts, 1 balancer trolley, 1 hose/cable trolley for festoon, 1 end stop and 1 end cap.

CEILING MOUNTED COLUMNS

Do not include booms but do include safety plate and integral safety chain.

BOOM AND TROLLEY DETAILS

Sizes and configurations other than those shown may be made-up by ordering individual components

Kit numbers listed assume typical 3/8" (9mm) I.D. hose with saddle to handle O.D. range of 0.60"-0.94" (15-24mm). If optional saddle with O.D. range of 0.31"-0.59" (08-15mm) is desired, substitute "1" for "2" as last digit of model number. Example: WCS-060301.

Jib Kits *continued*

Ceiling mounted, 50 lb capacity jib kits

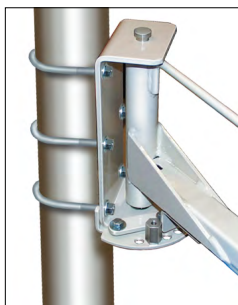

W5S-SK MANUAL BOOM STOP

Have the flexibility of a swing boom but need limit the swing in one or both directions? The boom stop (below) has manually positioned (screw-in) stops that limit swing to 15°, 30°, 45°, or 60° in either direction. Stops are easily installed on 50 lb. capacity swing booms without drilling or welding.



HWS-FMK1 KITS FOR MOUNTING FANS TO CEILING COLUMNS

Kit includes two U-Bolts and 13.50" w x 5.25" h Mounting Plate. End-user drills holes for fans. Column and fans are not included.

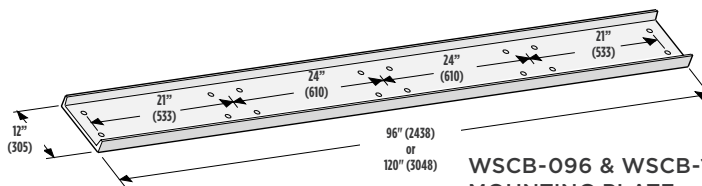

WSCB-096 & WSCB-120 MOUNTING PLATE

Optional. Attaches to ceiling cross members for mounting jib to ceiling structures. Pre-drilled in three places to match jib base.

MOUNTING PLATE 12" x 96" (304 x 2438)	WSCB-096
MOUNTING PLATE 12" x 120" (304 x 3048)	WSCB-120

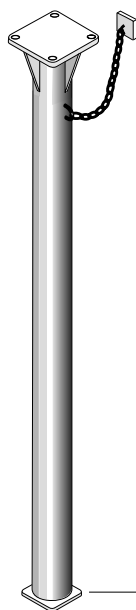

SAFETY PLATE

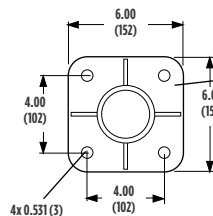

WCS-060902

6 ft.(1.8m) swing boom on 9 ft.(2.7m) column. Other models available with 3 ft. to 8 ft. (0.9-2.4m) column. See chart.

CEILING MOUNTED COLUMNS

Rugged 3.0" O.D. x 2.5" I.D. (76 x 64mm) welded steel tube. Beige polyester finish. Includes integral mounting base and 3' (0.9m) safety chain. Plate at bottom prevents equipment mounted on column from sliding off. Mounting hardware not included. See chart to left for model numbers.

USE: Supports tool rail booms or horizontal support members. Gets booms and tools up and out of the way, freeing floor space.

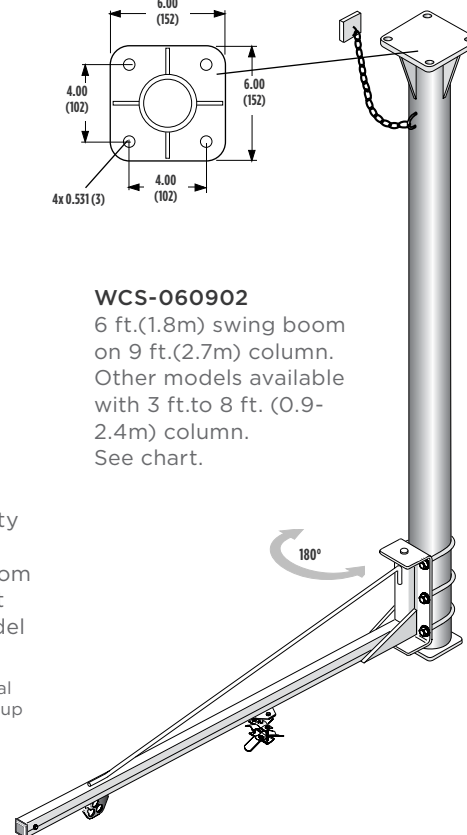

WS-UB U-BOLT ASSEMBLY Zinc plated steel

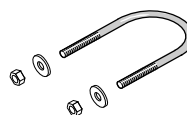

USE: Secures boom bracket or other flat plates to vertical column.
NOTE: Three required to mount boom.

Aluminum Track Components

Add on or build your own design / for loads up to 50 lbs (22.5 kg)

Extruded aluminum rail features double tracks (top and bottom), one for trolleys and the other for mounting components or concealing hose or cable. Inside dimensions of the larger track is same as WS50 steel rail and fits standard WS50 trolleys, brackets, stops, etc. (following page). Select from a full assortment of construction brackets (below), designed specifically for aluminum rail. All mounting hardware included with brackets. Brackets have black polyester finish with zinc plated steel hardware.

RAIL LENGTH ft. in. (m)	BEIGE MODEL NO.	NATURAL MODEL NO
2' 5" (0.8)	WA50-T029	WA50-N029
3' 0" (0.9)	WA50-T036	WA50-N036
4' 0" (1.2)	WA50-T048	WA50-N048
5' 0" (1.5)	WA50-T060	WA50-N060
6' 0" (1.8)	WA50-T072	WA50-N072
7' 0" (2.1)	WA50-T084	WA50-N084
20' 0" (6.1)	N/A	WA50-N240
45° Angle Brace 1' 5" (0.4)	WA50-TB17	WA50-NB17

Consult factory for lengths not shown above.

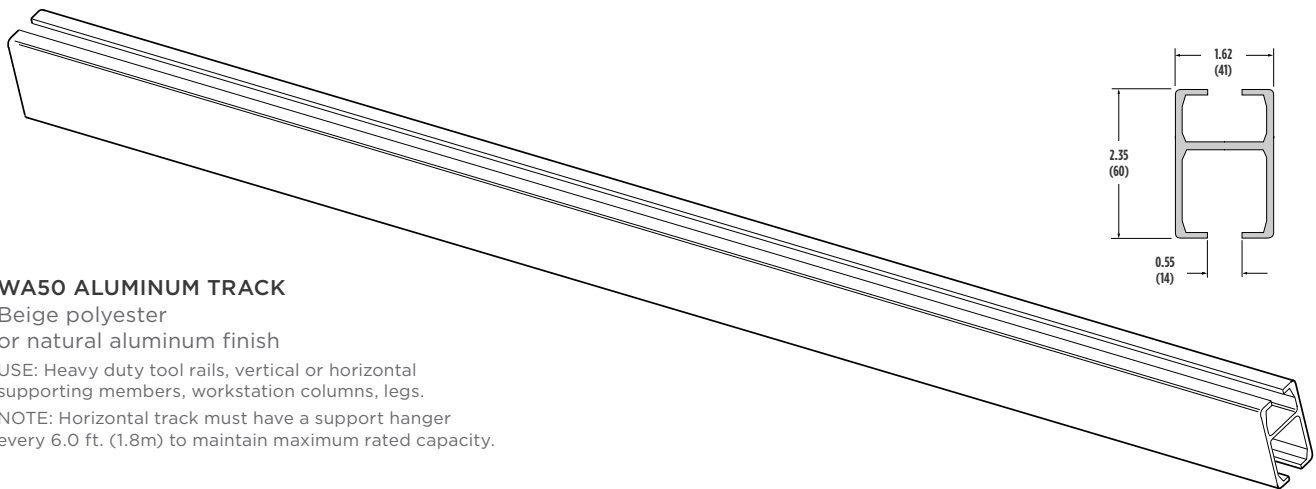

WA50 ALUMINUM TRACK



Beige polyester
or natural aluminum finish

USE: Heavy duty tool rails, vertical or horizontal supporting members, workstation columns, legs.

NOTE: Horizontal track must have a support hanger every 6.0 ft. (1.8m) to maintain maximum rated capacity.

Aluminum Track Components *continued*

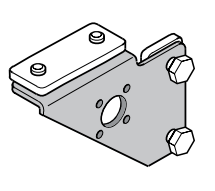
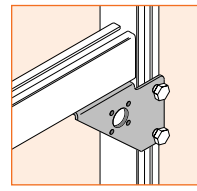
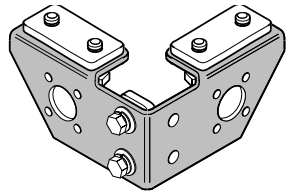
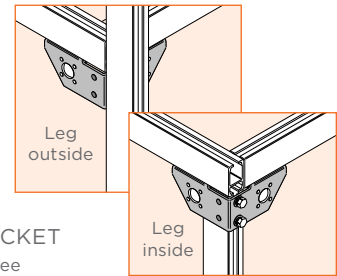
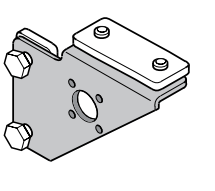
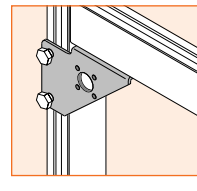
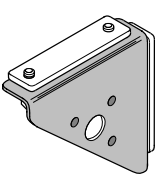
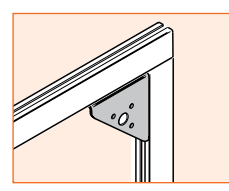
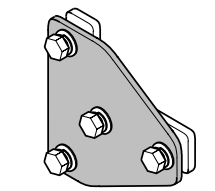
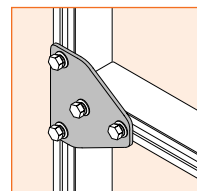
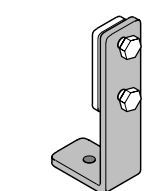
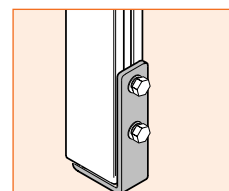
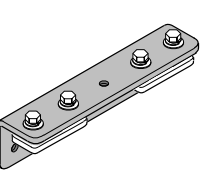
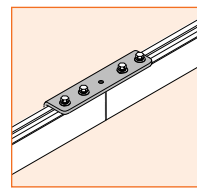
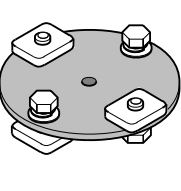
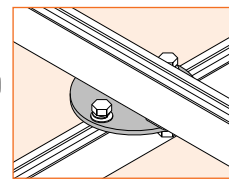
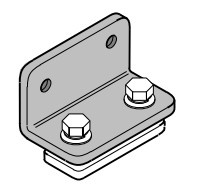
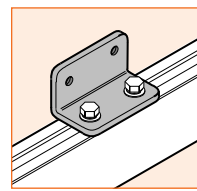
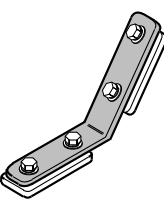
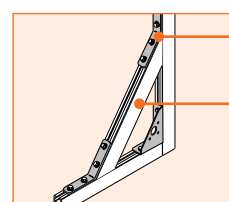
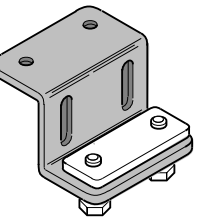
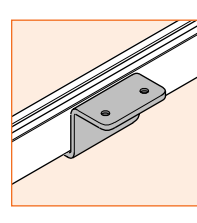
Add on or build your own design / for loads up to 50 lbs (22.5 kg)

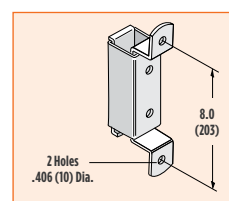
		<p>WA-FBR FRAMING BRACKET RIGHT HAND USE: Attach rail perpendicular to rail. Mount electrical boxes or hose connectors.</p>			<p>WA-CB CORNER BRACKET USE: Join three perpendicular rails.</p>
		<p>WA-FBL FRAMING BRACKET LEFT HAND USE: Attach rail perpendicular to rail. Mount electrical boxes or hose connectors.</p>			<p>WS-AB ANGLE BRACKET USE: Join rails at right angles.</p>
		<p>WA-TP T-PLATE USE: Use inside or outside. Install vertically or horizontally.</p>			<p>WA-LF LEVELER FOOT USE: Forms smooth foot. Adjust to level structure.</p>
		<p>WA-SA SPLICE ANGLE USE: Designed to allow precise joining for unrestricted trolley movement.</p>			<p>WA-HD HANGER DISK USE: Join crossing rails at right angles. Hang rails from other supports.</p>
		<p>WA-AMB ANGLE MOUNTING BRACKET USE: Hang rail to wall or other vertical support. Also attach sound boards, plywood to structures.</p>			<p>WA-AB ANGLE BRACE BRACKET (45°)</p>
		<p>WA-TMB TOP MOUNTING BRACKET USE: Attach top to bench.</p>			<p>WA50-TB17 or WA50-NB17 17" Aluminum Angle Brace Cut 45° On Both Ends (see chart above).</p>
			<p>WA50-MP UNIVERSAL BASE Zinc plated steel USE: Weld or bolt to new or existing benches or conveyors. Provides pocket for mounting WA50 rail. Cannot be used with WS50 rail.</p>		

Steel Track, 30 lb.

For loads up to 30 lbs (13.5 kg)

Separate **TOOL RAIL COMPONENTS** allow you to build your own workstations quickly and inexpensively. Or retrofit existing stations. Finished as shown, all parts are the same high quality included with kits and guaranteed to be interchangeable. Components shown are designed for use with WS30 rail. Starred (*) items may also be used with WS50 or extruded aluminum rails. Mounting hardware, where required, is included.

RAIL LENGTH ft. (m)	MODEL NUMBER
3.0 (0.9)	WS30-T03
4.0 (1.2)	WS30-T04
5.0 (1.5)	WS30-T05
6.0 (1.8)	WS30-T06
7.0 (2.1)	WS30-T07
8.0 (2.4)	WS30-T08
9.0 (2.7)	WS30-T09

Consult factory for lengths not shown above.

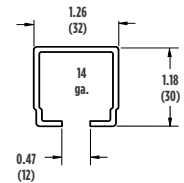
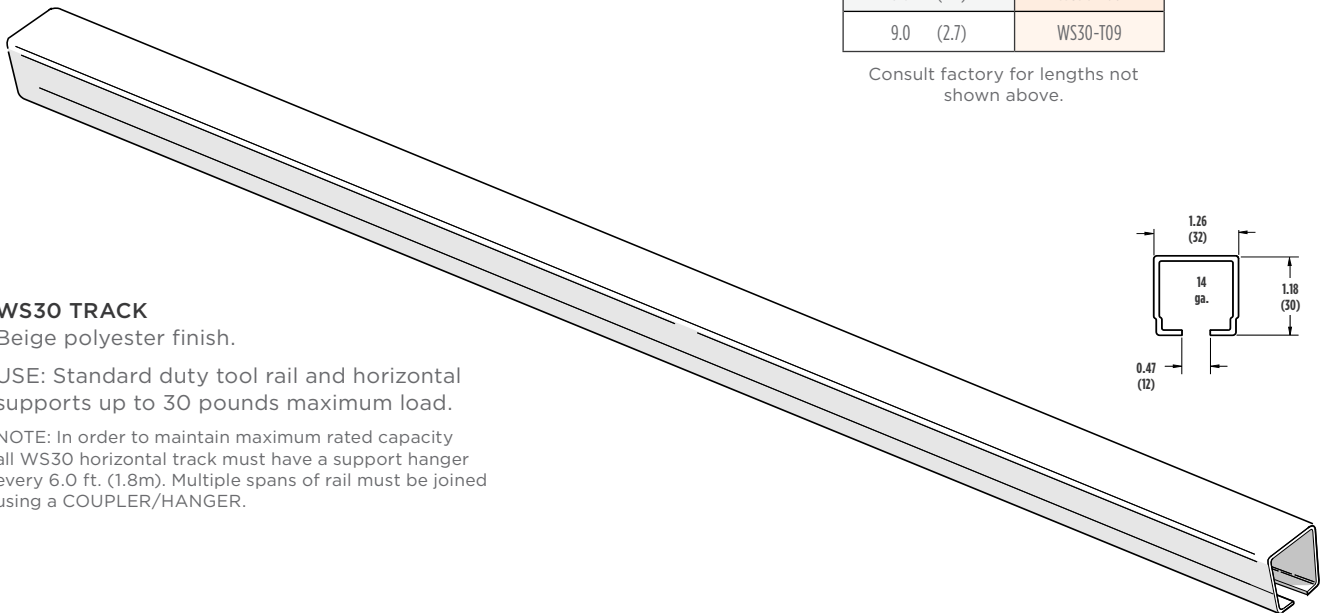

WS30 TRACK

Beige polyester finish.

USE: Standard duty tool rail and horizontal supports up to 30 pounds maximum load.

NOTE: In order to maintain maximum rated capacity all WS30 horizontal track must have a support hanger every 6.0 ft. (1.8m). Multiple spans of rail must be joined using a COUPLER/HANGER.

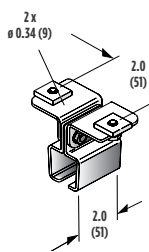

WS30-HG HANGER

Black polyester finish
USE: Hang/support single spans of WS30 rail from WS50, WA50 Extruded Aluminum rail or other suitable support.

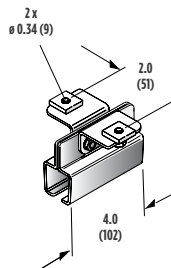

WS30-CH COUPLER/HANGER

Black polyester finish
USE: Connects and hangs multiple spans of WS30 rail from WS50, WA50 Extruded Aluminum rail or other suitable supports.

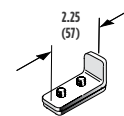

WS30-ES END STOP

Zinc plated steel
USE: Keeps trolley movement within preselected limits.

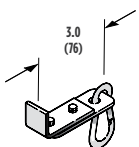

WS30-ESH END STOP HOOK

Zinc plated steel
USE: Supports tool balancer. Also acts as end stop.

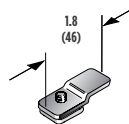

WS-HC* HOLDOWN CLIP

Black polyester finish
USE: Affixes conveyors and other machines to top of rail.

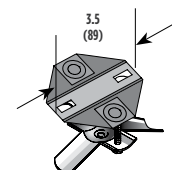

WS-EC01*
0.31 - 0.59 O.D. (08 - 15mm)
WS-EC02*
0.60 - 0.94 O.D. (15 - 24mm)
END CLAMP ASSY

USE: Supports hose/cable and prevents trolley overtravel.

Steel Track, 30 lb. *continued*

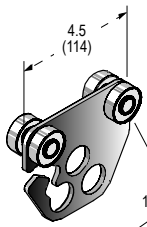

**WS30-BTL
BALANCER TROLLEY**
Black polyester finish
USE: Moving support for tool balancers, etc.
Runs in WS30 tool rail.



**WS30-BTS SINGLE
ROLLER
BALANCER TROLLEY**
Black polyester finish
USE: Tool balancer trolley.
Runs in WS30 tool rail.

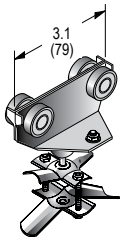

WS30-HT01*
0.31 - 0.59 O.D. hose
(08 - 15mm)
WS30-HT02*
0.60 - 0.94 O.D. hose
(15 - 24mm)
HOSE/CABLE TROLLEY
Black polyester finish
USE: Moving cable/hose clip.

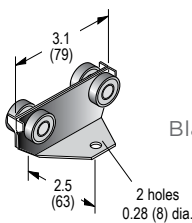

**WS30-O3TP
PLAIN TROLLEY**
Black polyester finish
USE: Utility trolley

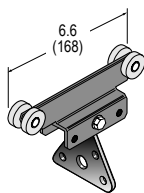

**WS30-SPT
SWING PLATE
TROLLEY**
Black polyester finish
USE: Designed for use with Hose-Hider but also works extremely well alone.
Swinging tool hook aids lateral movement.

WS30-TB BENCH MOUNT

Black polyester finish
USE: Mounting WS30 rail vertically to bench top.

WS30-TBS

Backing Plate Optional
(Use beneath mounting surface.)

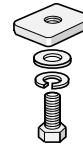
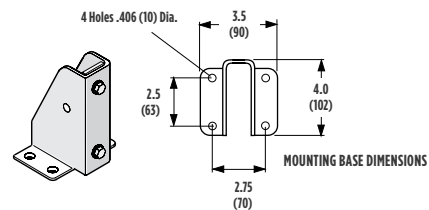

**WS30-TN*
TRACK NUT**

Zinc plated steel
USE: Attaches fixed components to rail.

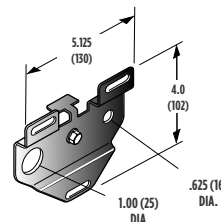

**WS-UH*
UNIVERSAL BRACKET**

Black polyester finish
USE: Supports hose or cable, peg board, etc.

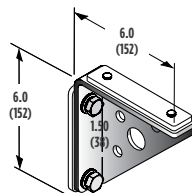

**WS-AB*
ANGLE BRACKET**

Black polyester finish
USE: Mounts horizontal tool rail to vertical column.

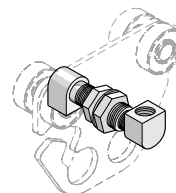

**WS00-CH*
900 CONNECTOR**

Brass. For 3/8" (9mm) hose
USE: Attach hose to balancer trolley or various brackets.

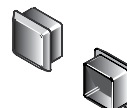

**WS30-EP
END CAP**

Black molded vinyl
USE: Caps off ends of rail for a finished look.

Steel Track, 50 lb.

For loads up to 50 lbs (22.5 kg)

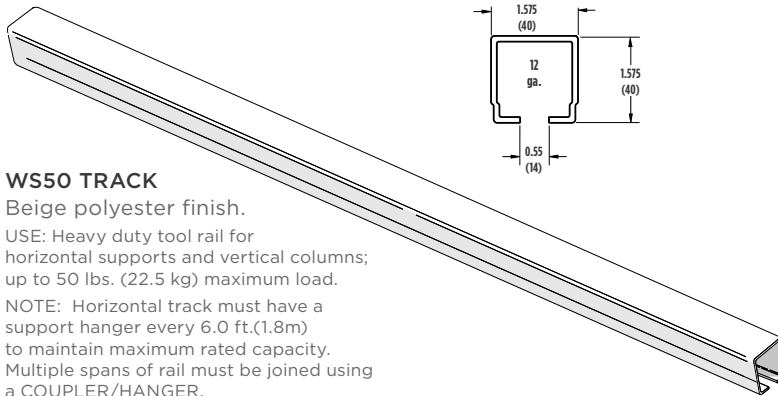

WS50 TRACK

Beige polyester finish.

USE: Heavy duty tool rail for horizontal supports and vertical columns; up to 50 lbs. (22.5 kg) maximum load.

NOTE: Horizontal track must have a support hanger every 6.0 ft.(1.8m) to maintain maximum rated capacity. Multiple spans of rail must be joined using a COUPLER/HANGER.

RAIL LENGTH ft. (m)	MODEL NUMBER
3.0 (0.9)	WS50-T03
4.0 (1.2)	WS50-T04
5.0 (1.5)	WS50-T05
6.0 (1.8)	WS50-T06
7.0 (2.1)	WS50-T07
8.0 (2.4)	WS50-T08
9.0 (2.7)	WS50-T09
10.0 (3.0)	WS50-T10
12.0 (3.6)	WS50-T12

Consult factory for lengths not shown left.

Separate **TOOL RAIL COMPONENTS** allow you to build your own workstations quickly and inexpensively. Or retrofit existing stations. Finished as shown, all parts are the same high quality included with kits and guaranteed to be interchangeable. All mounting hardware is included. All components below fit WS50 track. Items outside tan box may also be used with WA50 Extruded Aluminum Track.

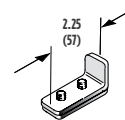

WS50-ES* END STOP

Zinc plated steel

USE: Keeps balancer trolley movement within preselected limits.

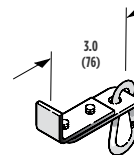

WS50-ESH* END STOP HOOK

Zinc plated steel

USE: Supports tool balancer. Adjustable location. Also acts as end stop.

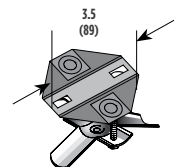

WS-EC01
0.31 - 0.59 O.D.
(08 - 15mm)

WS-EC02
0.60 - 0.94 O.D.
(15 - 24mm)

END CLAMP ASSY

USE: Supports hose/cable and prevents trolley overtravel.



WS50-EP* END CAP

Black molded vinyl
USE: Caps off ends of rail.

WS50-HG HANGER
Black polyester finish.
USE: Hangs single spans of WS50 track from WS50 or WA50 rail and other suitable supports. Cannot be used to hang WA50 track.

WS50-CH COUPLER/HANGER
Black polyester finish.
USE: Connects and hangs multiple spans of WS50 track from WS50 or WA50 track and other suitable supports. Cannot be used to hang WA50 track.

WS50-MP UNIVERSAL BASE
Zinc plated steel
USE: Weld or bolt to new or existing benches or conveyors. Provides pocket for mounting WS50 column. Cannot be used with WA50 rail.

Steel Track, 50 lb. *continued*

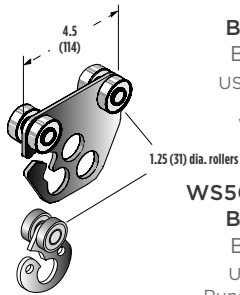

WS50-BTL*
BALANCER TROLLEY
 Black polyester finish
 USE: Moving support for tool balancers, etc. Runs in WS50 or WA50 tool rail.

WS50-BTS* SINGLE ROLLER
BALANCER TROLLEY
 Black polyester finish
 USE: Tool balancer trolley. Runs in WS50 or WA50 tool rail.

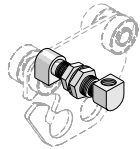

WS00-CH*
900 CONNECTOR
 Brass. For 3/8" (9mm) hose.
 USE: Attach hose to balancer trolley or various brackets.

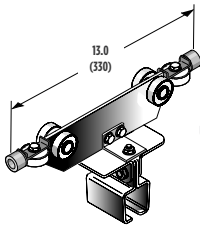

WS50-10HR
ROLLING HANGER
 Black polyester finish
 USE: Supports tool rail beneath track to provide six way tool positioning. Runs in WS50 steel or WA50 aluminum rail. Hanger will support WS50 track only.

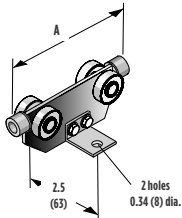

WS50-06TP* **WS50-10TP***
 A=6.25 (158) A=10.0 (254)

PLAIN TROLLEY
 Black polyester finish
 USE: Utility trolley. Runs in WS50 or WA50 rail.

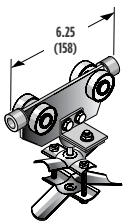

WS50-HT01* **WS50-HT02***
 0.31 - 0.59 O.D. hose 0.60 - 0.94 O.D. hose
 (08 - 15mm) (15 - 24mm)

HOSE/CABLE TROLLEY
 Black polyester finish
 USE: Moving cable/hose clip. Runs in WS50 or WA50 tool rail.

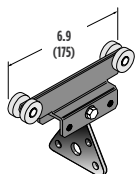

WS50-SPT
SWING PLATE TROLLEY
 Black polyester finish
 USE: Designed for use with Hose-Hider but also works extremely well alone. Swinging tool hook aids lateral movement. Runs in WS50 or WA50 tool rail.

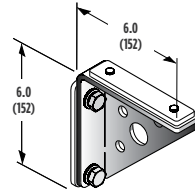

WS-AB*
ANGLE BRACKET
 Black polyester finish
 USE: Mounts horizontal tool rail to vertical column.

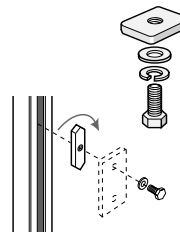

WS50-TN* TRACK NUT
 Zinc plated steel
 USE: Attaches fixed components to rail. Slides in from rail end.

WS50-EZTN* E-Z NUT
 Zinc plated steel
 USE: Attaches fixed components to rail, from front.

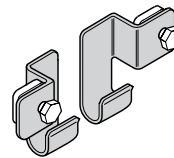

WS50-HBS
HOOK BRACKET SET (2)
 Black polyester finish
 USE: Hang rod to hold rolls of wrap, wire, etc.

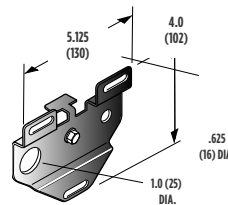

WS50-HR03 (04) (05) (06)
HANGER ROD
 5/8" O.D. X 3/8" I.D. unfinished steel tube in length (ft.) shown

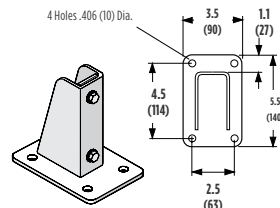

WS-UH*
UNIVERSAL BRACKET
 Black polyester finish
 USE: Supports hose or cable, peg board, etc.

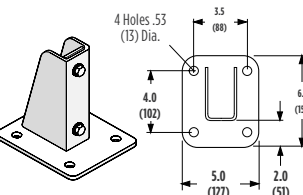

WS50-TB*
BENCH MOUNT
 Beige polyester finish

WS50-TBS
BACKING PLATE
 (Same size as Mounting Base) Optional

WS50-MB* FLOOR MOUNT
 Black polyester finish

WS50-MBS
BACKING PLATE
 (Same size as Mounting Base) Optional

Booms and Mounting Base

FIXED OR 180° SWINGING WS50 BOOMS

USE: Wall or column mounted tool rail; or use two fixed booms as support for horizontal tool rail. (Cross rail and hangers not included). End stop and end cap included. *Eight foot (2.4m), ten foot (0.3m) and 18 foot (5.4m) booms include ladderstyle reinforcing superstructure. Trolley extra. Beige polyester finish.

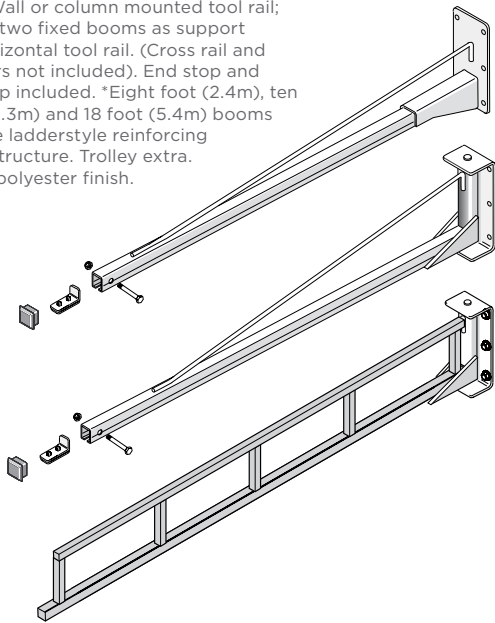

WS50 RAIL for loads up to 50 lbs.(22.5 kg)		
BOOM LENGTH ft. (m)	BOOM TYPE	MODEL NUMBER
4.0 (1.2)	Fixed	WF50-WS04
4.0 (1.2)	Swing	WS50-WS04
6.0 (1.8)	Fixed	WF50-WS06
6.0 (1.8)	Swing	WS50-WS06
8.0* (2.4)	Fixed	WF50-WS08
8.0* (2.4)	Swing	WS50-WS08
10.0* (3.0)	Fixed	WF50-WS10
10.0* (3.0)	Swing	WS50-WS10
12.0* (3.7)	Swing	WS50-WS12
18.0* (5.4)	Swing	WS50-WS18

*Features ladder style reinforcing rather than tie rod. Model WS50-WS18 has stacked (doubled) rail for additional strength.

TYPE	Dim. A in. (mm)
Swing	8.12 (206)
Fixed	7.75 (197)

MOUNTING HOLE LAYOUT 4'-12' BOOMS

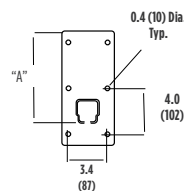

MOUNTING HOLE LAYOUT 18' BOOM

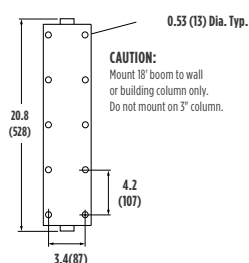

RAIL MOUNTED FIXED OR SWING BOOMS

USE: Tool rail mounted to WS50 or WA50 vertical column. End stop, end cap, safety bolt and all hardware included. Trolley extra. Beige polyester finish.

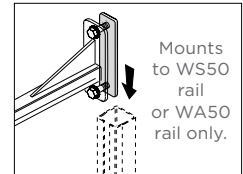

WS30 RAIL for loads up to 30 lbs.(13.5 kg)		
BOOM LENGTH ft. (m)	BOOM TYPE	MODEL NUMBER
3.0 (0.9)	Fixed	WF30-DS03
3.0 (0.9)	Swing	WS30-DS03
4.0 (1.2)	Swing	WS30-DS04

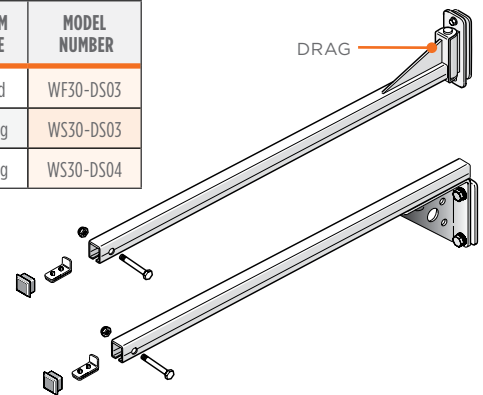

WALL MOUNTED BOOMS

USE: Wall mounted tool rail. End stop, end cap and safety bolt included. Trolley extra. Beige polyester finish.

BOOM TYPE	Dim. A in. (mm)
Fixed	3.38 (85)
Swing	3.19 (81)

WS30 RAIL for loads up to 30 lbs.(15.5 kg)		
BOOM LENGTH ft. (m)	BOOM TYPE	MODEL NUMBER
3.0 (0.9)	Fixed	WF30-WS03
3.0 (0.9)	Swing	WS30-WS03

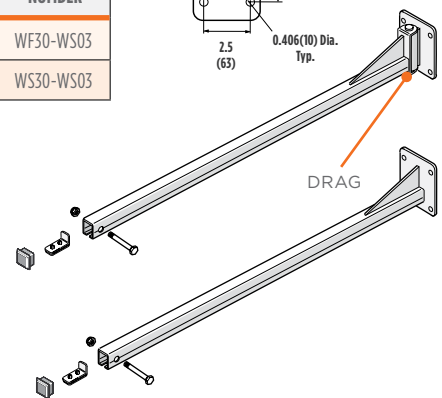
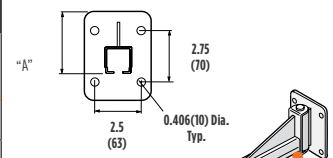

WS-UB U-BOLT ASSEMBLY

USE: Secures 4'-10' booms or other flat plates to 3" dia. vertical column. Three are required to mount boom onto vertical column. Do not use for mounting 18' boom (#WS50-WS18). Zinc plated steel.

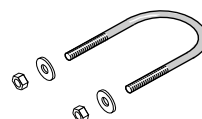

Booms and Mounting Bases *continued*

Bases and Supports

These bases are larger than those listed with the track components and are used primarily when a more rigid structure is desired. All bases include all hardware for mounting rail to base.

BENCH LEG BASE

USE: Mounts workstation to bench by providing a "pocket" into which WS50 track may be fitted. Models for 30"(762) or 36"(914) deep benches. Universal hole pattern in foot plus adjustable "Joiner Plate Box" provide solid grip to the bench leg. Includes hardware required for mounting rail to base. Does not include hardware required to mount base to bench. Joiner plate box included and also available separately. Black polyester finish.

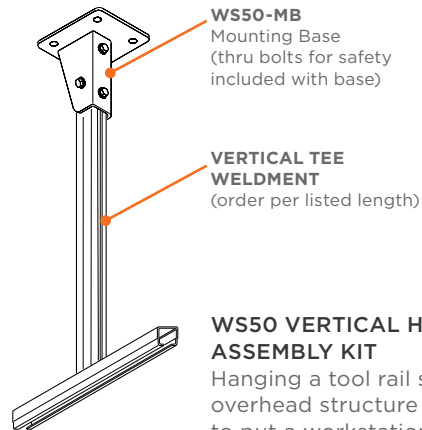
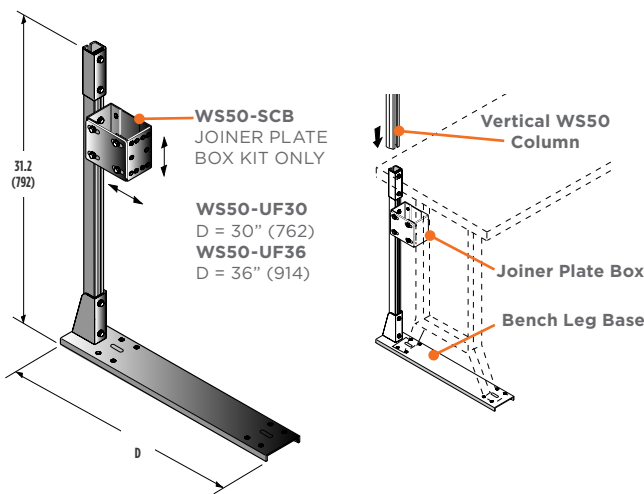

62829003	3 ft.
62829006	6 ft.
62829008	8 ft.
62829009	9 ft.
62829010	10 ft.
62829011	11 ft.
62829012	12 ft.

WS50 VERTICAL HANGER SUPPORT ASSEMBLY KIT

Hanging a tool rail safely from an overhead structure may be the best way to put a workstation where it's needed. These kits consist of a 12" long cross rail section welded to a 3 ft., 6 ft. or 9 ft. vertical rail section and a WS50-MB Mounting Base. These 50 lb. capacity hangers are for use with WS50 steel track and are sold only as kits. Tool track must be supported every six feet to preserve 50 lb. capacity rating.

SUPPORT CLAMP

WS50-SC-For WS50 (steel) Rail
WA50-SC-For WA50 (Aluminum) Rail

USE: Fasten rail to back of bench for added stability.

Typically used with WS50-MB base. Black polyester finish.

WS60-SC-For WS60 (steel) Rail also available. Mounting dimensions differ from WS50-SC.

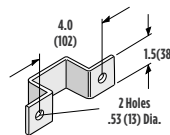
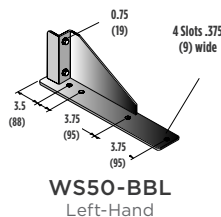

TABLE BRACKETS

USE: Mounts WS50 or WA50 vertical support columns to typical work bench. Provides greater rigidity when mounted to sheet metal tops than standard bases. For even greater strength, use model #WS50-BBS backing plate (optional) beneath bench top. Includes hardware for mounting rail to bracket. Does not include hardware for mounting base to bench. Black polyester finish.



WS50-BBL
Left-Hand



WS50-BBR
Right-Hand

Retrievers

Reels for pulling various loads

RETRIEVER REELS provide a constant pulling force over a specified distance. Working length (in feet) and pull (in pounds) shown in chart below. Reels feature rugged steel construction with polyester baked finish and rigid mounting bracket. Spring is permanently lubricated. Cable is 920 lb. (414kg) test 0.09" (2.3mm) dia. 7 x 7 strand galvanized steel aircraft cable nylon covered to 0.12" (3.0mm) O.D. Reels include end clip and adjustable cable stop. Net weight of all models 10 lbs. (4.5kg).

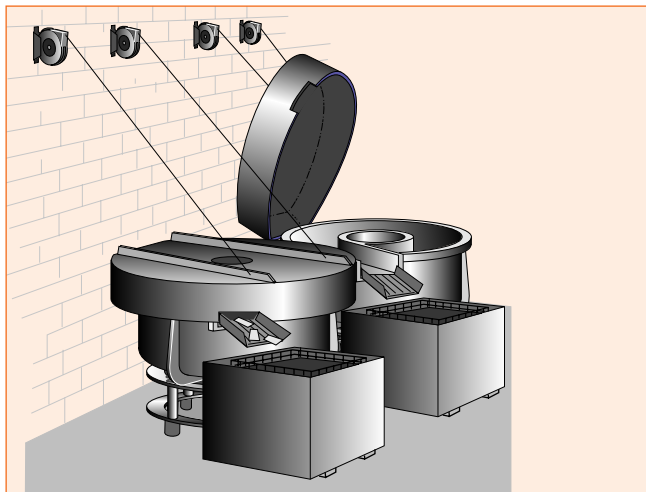

Sound dampening covers on vibrating cleaners make sound level in a metal finishing plant more acceptable. Two RETRIEVERS lift part of each cover's weight and make opening easier and safer.

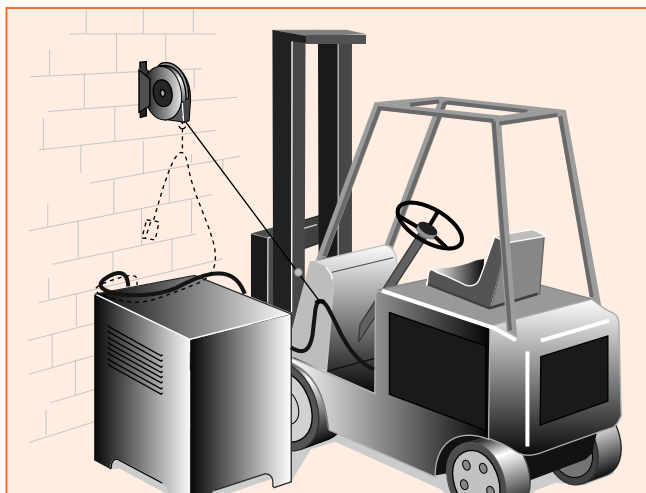

RETRIEVER keeps fork truck charging cables out of the way when not in use, reducing damage and need for costly replacement. Mount retriever on wall, as shown here, or directly on charger.

APPLICATION

RETRIEVER REELS are available in two mounting types: (A) with pull parallel to mounting surface. (B) with pull perpendicular to mount. Choose type which provides payout in direct line to attachment.

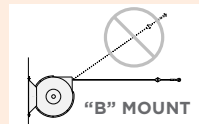
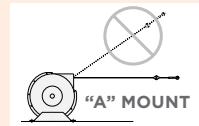

DIMENSIONS

ALL DIMENSIONS IN INCHES (mm)

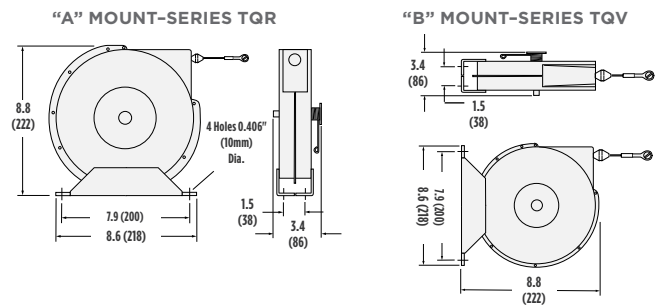

WORKING LENGTH CHART

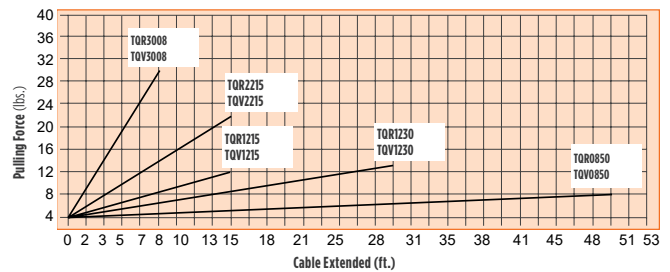

SELECTION CHART

CABLE LENGTH ft. (m)	MINIMUM PULL** lbs. (kg)	MAXIMUM PULL** lbs. (kg)	"A" MOUNT MODEL NO.	"B" MOUNT MODEL NO.
50 (15.0)	0.5 (0.2)	7.5 (3.4)	TQR0850	TQV0850
15 (4.5)	3.0 (1.4)	12.0 (5.4)	TQR1215	TQV1215
30 (9.0)	3.0 (1.4)	12.0 (5.4)	TQR1230	TQV1230
15 (4.5)	7.5 (3.4)	22.0 (9.9)	TQR2215	TQV2215
8 (2.4)	8.0 (3.6)	30.0 (13.5)	TQR3008	TQV3008

*Cable lengths listed are for "active" or "working" cable. Includes end clip and cable stop. **Pulling forces above are approximate and depend on exact spring adjustment or pre-tensioning by the user. Reels are pre-set at the factory at the minimum pull. Adjusting reel to suit application is user's responsibility.

Packaging Workstations

Packaging Workstation

Speed your shipments out the door. **SHIPPING STATION KIT** was designed for utility and flexibility. Strong, light weight extruded aluminum frame with steel joining brackets and maple bench tops may be assembled in a variety of configurations to fit your space and job requirements. Adjustable light with two 48" fluorescent lamps, packaging foam dispenser with cutting bar, adjustable shelf, power strip and swing arm mounted monitor and printer trays are included as standard. Unique wire trough on back helps organize and protect sensitive computer cables, power cords, etc. Station measures 120" long x 32.5" deep x 87" high in configuration shown. All metal parts have durable polyester finish. Aluminum is beige, steel brackets are matte black. All hardware is zinc plated steel.

DESCRIPTION	MODEL NO.
30" deep Packaging Workstation	HWS-STAI20



NOTE: MONITOR, KEYBOARD, MOUSE, BAR CODE PRINTER, LABEL PRINTER AND OTHER SIMILAR EQUIPMENT ARE NOT INCLUDED.

Minimize reaching for parts

Solve parts logistics problems

Carts offer three ways to supply small parts to workstations in an ergonomically friendly manner. Properly positioned parts bins at assembly points minimize stretching and reaching which can lead to injuries. These carts are also great for temporary job task locations.

Place 'n Pick Shelf Cart

Complete kits with three 12" (305mm) deep adjustable shelves are available in 30" (762mm), 42" (1067mm), 54" (1372mm), or 66" (1676mm) widths. Or, if you want to build a custom cart, frame kits allow you to install 12" (305mm) or 18" (457mm) deep shelves and other accessories like Bin Bars on which to hang bins, electric power strips or air manifolds, even swing arms (see workstation accessory page in this catalog). Maximum capacity 50 lbs. (22.5 kg) per shelf.



Cart kits include three 12" (305mm) deep x 30" (762mm), 42" (1067mm), 54" (1372mm) or 66" (1676mm) wide steel shelves, sturdy extruded aluminum frame, steel construction brackets, and all hardware. Aluminum frame members and shelves have beige baked polyester finish. Steel brackets, including shelf brackets, are black. Also included are four heavy-duty locking casters, and black end caps.

SHELF CART KIT & COMPONENT LISTING

Description	Model Number
Complete Cart Kit-(3) 12"D x 30"W Shelves included	HWP-SC30
Complete Cart Kit-(3) 12"D x 42"W Shelves included	HWP-SC42
Complete Cart Kit-(3) 12"D x 54"W Shelves included	HWP-SC54
Complete Cart Kit-(3) 12"D x 66"W Shelves included	HWP-SC66
Individual Components	
Frame Kit*-For 30" Wide Shelves	HWP-SC03
Frame Kit*-For 42" Wide Shelves	HWP-SC04
Frame Kit*-For 54" Wide Shelves	HWP-SC05
Frame Kit*-For 66" Wide Shelves	HWP-SC06
Shelf-12"D x 30"W	WS50-SS03
Shelf-12"D x 42"W	WS50-SS04
Shelf-12"D x 54"W	WS50-SS05
Shelf-12"D x 66"W	WS50-SS06
Shelf-18"D x 30"W	WS50-SS183
Shelf-18"D x 42"W	WS50-SS184
Shelf-18"D x 54"W	WS50-SS185
Shelf-18"D x 66"W	WS50-SS186

*Frame kits include aluminum and steel members, four locking casters, end caps and all assembly hardware. Width shown is inside-to-inside dimension. Shelves fit inside frame uprights. Shelves that hang in front of uprights are available. See catalog for details on shelves and other accessories that can be easily installed on frame.



Minimize reaching for parts *continued*

Solve parts logistics problems

ROLLING BIN RACK



Hang bin boxes on both sides, position cart in the best place for greatest workplace efficiency and ergonomics. Move easily if task or worker changes. Six bin supports may be positioned at desired heights. Bin boxes not included.

- Sturdy extruded aluminum frame with heavy-duty steel brackets.
- Includes six bars for holding bin boxes
- Four locking, swivel casters.
- 300 lb. max capacity.

DIMENSIONS:

77"h x 36"d x 33.6"w

DESCRIPTION:

Bin Box Cart with four casters

MODEL NO.:

HWP-BC01

GRAVITY FEED RACK



Semi-permanent (adjustable glides, not casters) designed for supplying parts bins to work areas. Two conveyor levels, each featuring four roller strips, fully adjustable slope and height. Sturdy steel stops prevent bin run-off. Roller strips supported along entire length by WS30 rail.

- Sturdy extruded aluminum frame with heavy-duty steel brackets.
- Adjustable glides, not casters.
- 300 lb. max capacity.

DIMENSIONS:

77"h x 36"d x 33.6"w

DESCRIPTION:

Gravity Feed Rack with Glides

MODEL NO.:

HWP-GFR

SUPPLY 'N RETURN™ GRAVITY FEED CART

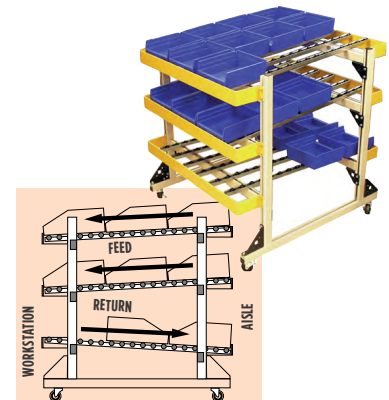

Three adjustable conveyors supply full bins to assembly area and return empty bins to aisle. Each level may be easily adjusted for optimum slope and spacing. May also be assembled with all three levels sloped toward work area. Adjustable safety yellow bin stops also protect ends of conveyors. Tough baked polyester finish. Optional adjustable side guides (not shown) may be added to keep bins aligned. Bins not included.

- Sturdy extruded aluminum frame with heavy-duty steel brackets.
- 18 adjustable roller strips.
- 300 lb. max capacity.
- Locking, swivel casters.

DIMENSIONS:

48"h x 48"d x 47"w

DESCRIPTION:

Supply 'n Return Cart

MODEL NO.:

HWP-GF444

Heavy-duty special purpose carts

Keep your plant flexible, yet safe

Push 'n Place™ Workstation

Maintain flexibility on the plant floor without sacrificing safety and productivity. The **ToolAssistPro** Push 'n Place portable workstation rolls easily on four heavy-duty locking, swivel casters. Constructed of strong extruded aluminum rail, it measures 36" deep and 90" high, including casters. Frame is 44" wide O.C. perfect under a 5' conveyor section or 60" bench. Tool bar is 60" long and can be fitted with splice angles to adjoin two or more units. Bin Bar, air manifold and balancer trolley with fitting plus 3/8" hose are standard. Frame is finished with beige baked polyester. Brackets are matte black. Assembly required.

NOTE:
Standard **ToolAssistPro** swing arms and other accessories may be used with this portable workstation.

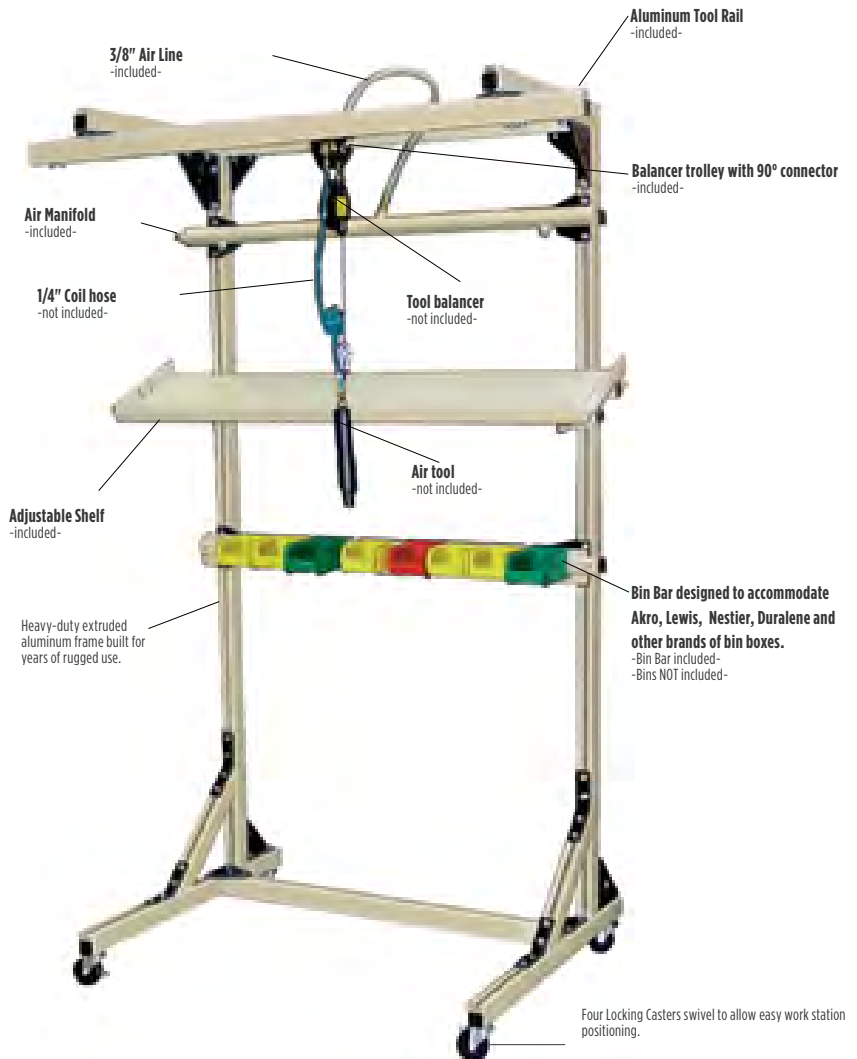

DESCRIPTION	MODEL NO.
Push 'n Place portable workstation	HWP-0475

Heavy-duty special purpose carts *continued*

Keep your plant flexible, yet safe

Wire Spool Cart

Solve production or maintenance wiring issues. Roll the wire to the job, unspool what you need, and return the cart to a convenient storage place. WA50 aluminum rail with formed steel brackets, cart measures 54" high, 36" deep and 33.6" wide with a 27" clear space between spool shaft brackets, which are fully adjustable. Available with four heavy-duty casters (two fixed and two swivel with locks), two fixed casters and two glides or, for semi-permanent installation, with four glides. Swivel casters may be installed at either front or back. All components, except hardware, finished with chip-resistant baked polyester coating. Rails are beige and brackets are black. Assembly required. MAXIMUM CAPACITY: 300 lbs.

Includes **Bin Bar** (bin boxes not included). Convenient storage for wire nuts and other fasteners or tools. Bin Bar designed to accommodate Akro, Lewis, Nestler, Duralene and other brands of bin boxes.



DESCRIPTION	MODEL NO.
Wire spool cart with four casters.	HWP-RC01
Wire spool cart with four glides.	HWP-RC02
Wire spool cart with two fixed casters and & glides.	HWP-RC03

Mobile Test Station

The Model HWP-TC01 Test Bed Cart represents the ultimate in versatility. Dual support rails adjust to any size electrical box. Box mounts easily with exclusive **E-Z NUT™** Track Nuts, furnished. Two coil hangers keep cable off floor while cart is being rolled to the job. Heavy duty shelf easily supports even the heaviest technical manuals. Bin Bar holds box bins for miscellaneous storage. Frame is strong extruded aluminum with beige baked polyester finish. All joining brackets are heavy steel with matte black polyester. Includes four locking, swivel casters and all assembly hardware. Bin boxes, electrical box and cables not included. Some assembly required.

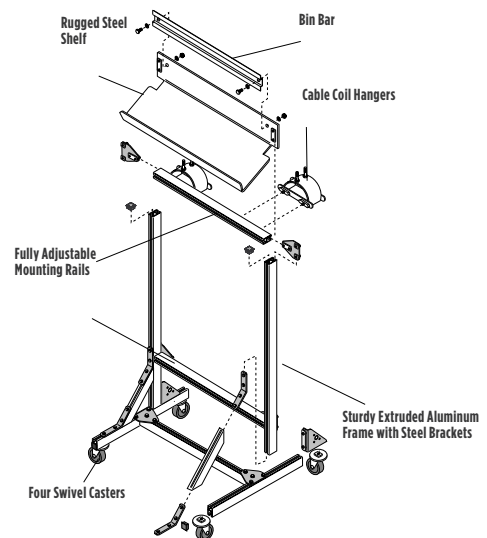

Front view with electrical box installed

DESCRIPTION	MODEL NO.
Mobile test station	HWP-TC01



A proud member of the Hubbell family.

©2023 Hubbell Incorporated. All rights reserved.
Hubbell and the Hubbell logo are registered trademarks
or trademarks of Hubbell Incorporated.
All other trademarks are the property of their respective owners.
www.hubbell.com/gleasonreel
HHI-GR-CAT-EN-01193 | 08/2023