

Non-Contact Speed Responsive Switches

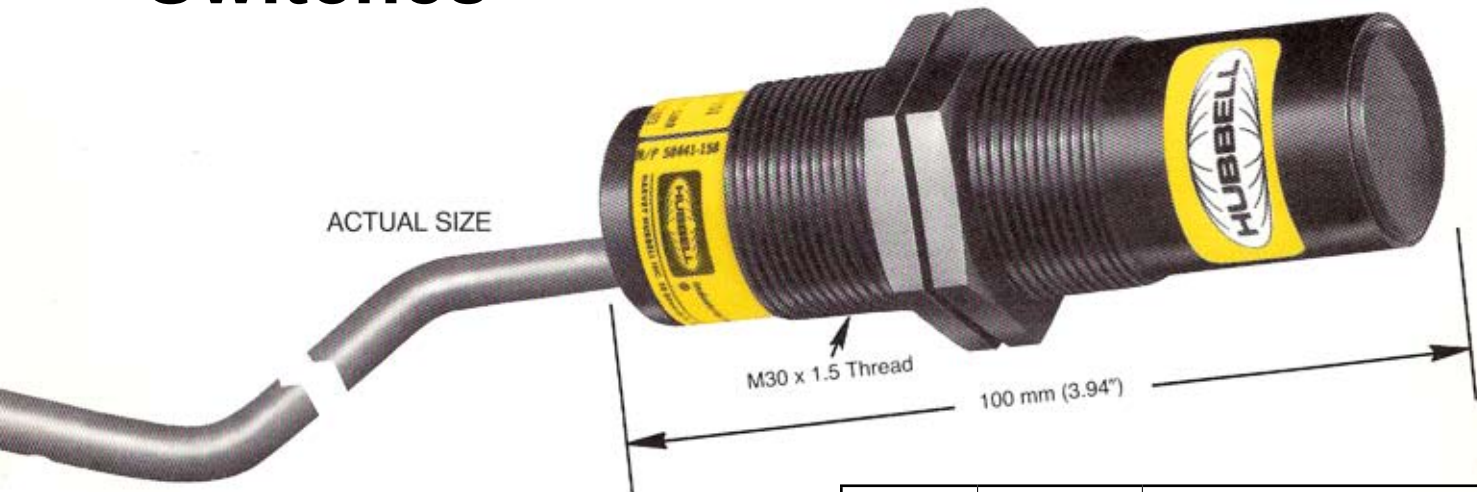

General Information

The 2310 Non-Contact Speed Responsive Switch is a self-contained solid state device capable of sensing the presence of metal without physical contact. This high-density tubular package senses metal targets in a nominal 10 mm (0.4") sensing distance from the sensing head for targets of a typical size, 30 mm (1.20") square by 1.5 mm (0.06") thick.

Benefits

- Solid State speed-Sensing Device
- Self-Contained Control Adjustments and Diagnostics
- Ease of Installation
- Maintenance Free
- Automatic Reset Each Cycle
- High Impact Housing

Applications

Numerous production control and related applications include underspeed as with chain, belt, screw, and related conveyors; also zero-speed sensing for web, belt or coupling breakage, etc. Specific production uses include start-up of motors for mixing units, rotary kilns, blower fans, mine pumps, sequencing conveyors, etc.

| Catalog Number | Part Number | Description |
|----------------|-------------|---------------------------------|
| 2310-LSP | HC48910101 | Low-Speed Plastic Housing |
| 2310-HSP | HC48910102 | High-Speed Plastic Housing |
| 2310-LSNP | HC48910151 | Low-Speed Nickel-Plated Sleeve |
| 2310-HSNP | HC48910152 | High-Speed Nickel-Plated Sleeve |

Operating Characteristics

Load Connection.....Series Load Actuation (See Fig. 2)
 Start-Up Time.....0.6 seconds
 Speed Range:
 Assemblies 101, 151.....6-150 RPM (Single Event)
 Assemblies 102, 152.....150-3600 RPM (Single Event)
 Sensing Distance.....15mm (See Fig. 4 - Table 5)
 Sensing Hysteresis (Distance).....2 mm
 Operating Hysteresis (Speed).....5%
 Sensing Tolerance.....Dependent on Target Material
 Temperature.....-20°C to +70°C
 Voltage.....±10%
 Operating Tolerance (Speed).....±10%

Low-Speed Sensors - designed to operate in speed ranges
6-150 RPM (Single Event)

High-Speed Sensors - designed to operate in speed ranges
150-3600 RPM (Single Event)

To sense slower speeds than those listed, multiple events should be detected in each revolution.



Speed Responsive Switches

Application Details

The 2310 Non-Contact Speed Responsive Switch is a two-wire series, load-activating sensor. It operates on the inductive proximity switch principle. It obtains its power from the same 120V, 60hz supply as the separately mounted output relay (supplied by others). The 2310 is series-connected with the coil of the output relay.

Easily recalibrated for "home" position, the 2310 permits easy resetting to compensate for belt stretching or slipping on conveyor applications, and for compensatory adjustments on variable speed operations.

As indicated earlier, the listed speed ranges are based on a **single** event or actuation per revolution. A typical application would involve sensing the key in a motor or gearbox shaft. The speed switch is available in two speed ranges:

- 2310-LSP & 2310-LSNP - 6 to 150 RPM*
- 2310-HSP & 2310-HSNP - 150 to 3600 RPM*

In order to sense slower speeds outside the listed ranges, multiple events or actuations per revolution must be used. An example of multiple event actuation might be the sensing of protruding bolt heads from a shaft coupling. If the coupling provides six bolt heads, the speed ranges would be divided by six with the slowest sensing speed being 1 RPM for the 101 assembly.

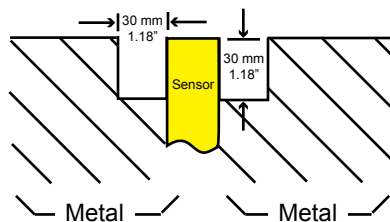

Fig. 1
Free Zone Area

Select a mounting area, keeping the Free Zone requirements (Fig. 1) in mind. The target must move laterally across the face of the speed switch. Actuating distance from the target to speed switch face is shown in Fig. 4 and Table 5 (Page 3). The information provides an estimated setup distance prior to actual starting.

Easy Installation

Connect the speed switch per the wiring diagram shown in Fig. 2 below. Apply power to the speed switch circuit and set the target in motion. The Red target LED on the rear of the speed switch should respond as the target passes by the front of the speed switch. See Fig. 3 below.

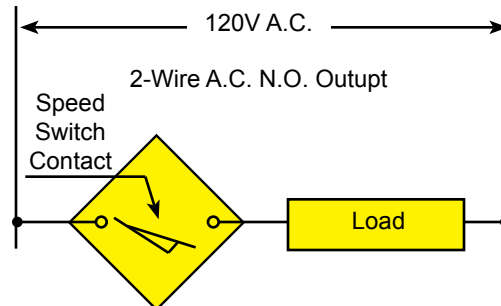

Fig. 2
Connection Diagram

The speed setting within a given sensor's range is adjustable with the 20-turn RPM adjustment potentiometer located behind the access screw. See Fig. 3 below. The initial setting of this potentiometer is made by first turning the potentiometer fully counterclockwise, then turning the potentiometer clockwise by the number of turns indicated by the speed setting graphs, Fig. 6 and Fig. 7 (Page 3). For most applications, the initial settings (clockwise turns) obtained from the graph will provide adequate accuracy. If greater precision is required, monitor the target revolutions with a hand tachometer.

If the Red target LED does **not** respond, move the switch closer to the target. If the Red LED is continuously on, move the switch farther away from the target. The operating range will be determined by the end points explained above. The ideal location of the speed switch is midway in this operating range.

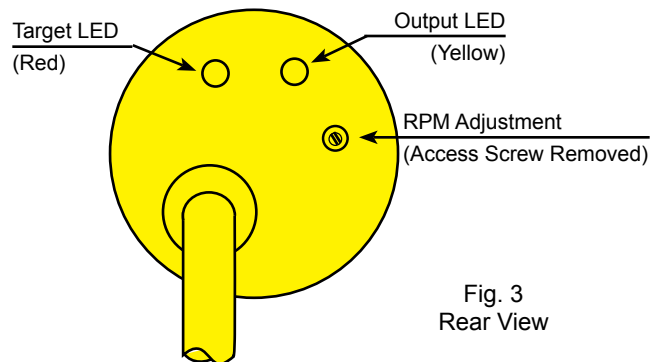

Fig. 3
Rear View

The Yellow output LED, Fig. 3, will light when the sensed speed is above the speed setting. **The Yellow output light also signals that the output triac is on and shows that the series-connected load is actuated.**



Simplified Setpoint Selection

A small instrument-size screwdriver is supplied by Hubbell to fit potentiometer for speed setting adjustments according to charts shown below. If speed tolerance is not critical, this speed setting can be the final adjustment.

LOW-SPEED POTENTIOMETER

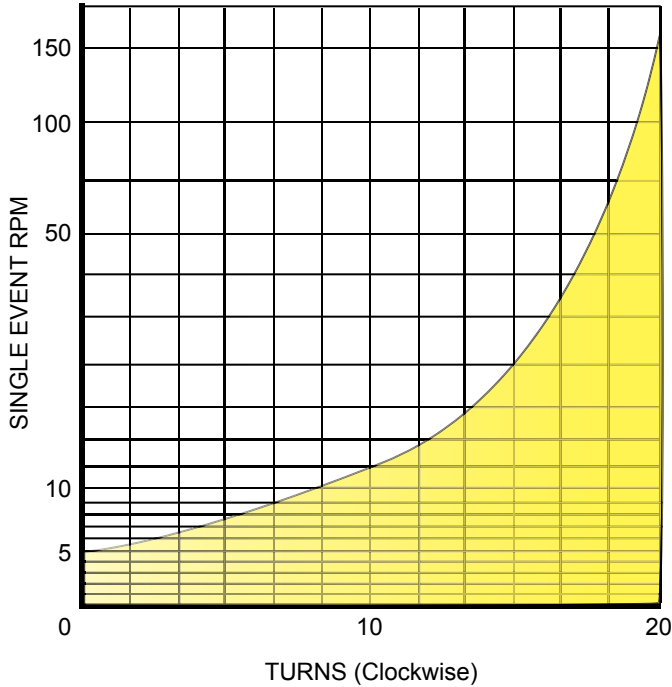

Fig. 6

HIGH-SPEED POTENTIOMETER

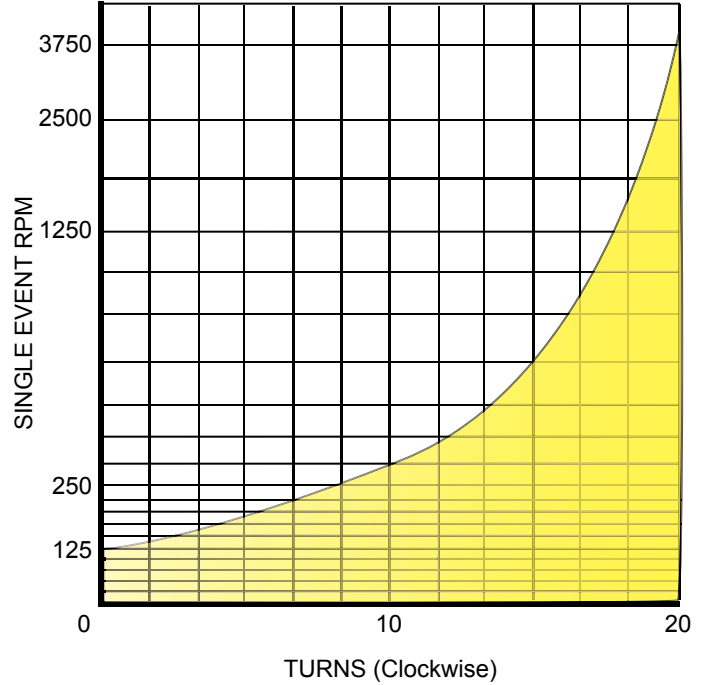

Fig. 7

LATERAL SENSITIVITY

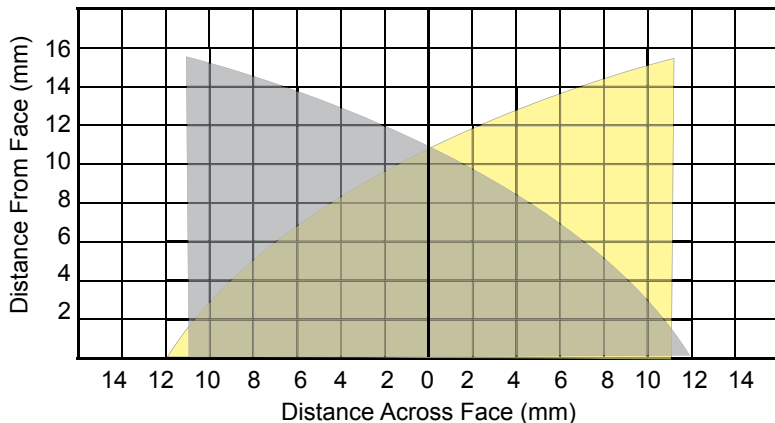

Fig 4

Standard Ferrous Target

30 mm x 30 mm 1.5 mm

Use factors from Table 5 below if target material other than steel is used:

Material Reduction Factors

| | |
|----------------------|------------|
| Steel..... | 1.0 |
| Stainless Steel..... | 0.7 to 0.8 |
| Aluminum..... | 0.3 to 0.5 |
| Brass..... | 0.3 to 0.4 |
| Copper..... | 0.3 to 0.4 |

Table 5



Switch and Accessories - Sizing and Mounting Detail

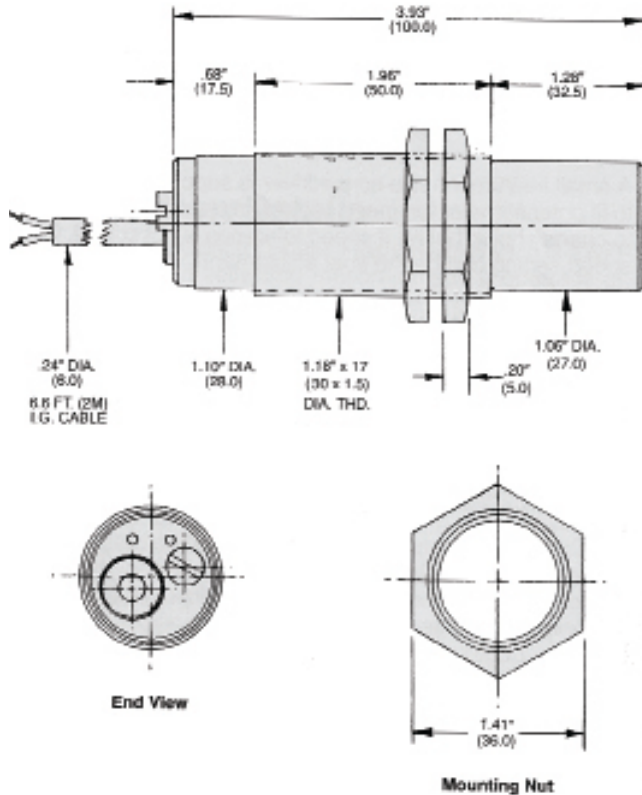

Note: All Dimensions are approximate

Optional Accessories

A mounting bracket is available as an accessory for mounting the Non-Contact Speed Switch. If the jam nuts provided with the switch are misplaced, they can be purchased using the part number below.

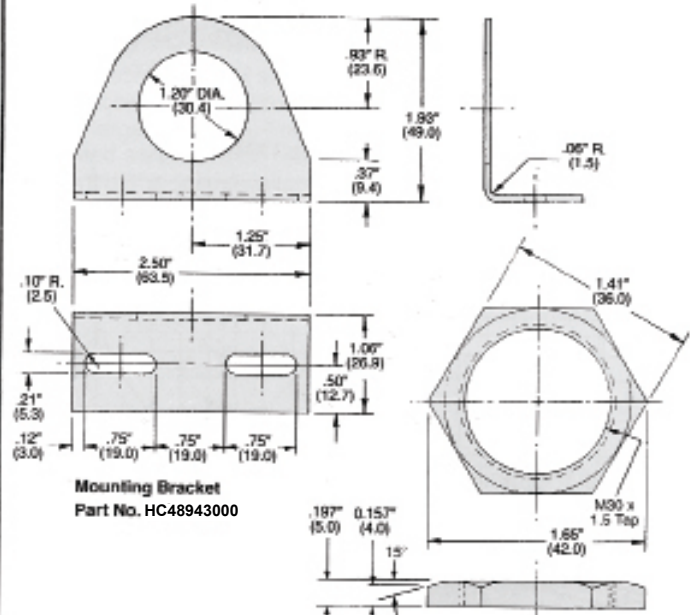

- Black Mounting Jam Nut - Part No. HC48916001
- *Nickel-Plated Brass Jam Nut - Part No. HC48916002
- *Metal nut not intended for use with plastic housing.*

Specifications

Electrical Data

| | |
|--|-------------------|
| Operating Voltage..... | 120V-132V |
| Line Frequency..... | 50-60hz |
| On-state voltage drop..... | 5.5 volts |
| Off-state leakage current..... | 10 ma. |
| Maximum load current**..... | 300 ma. |
| Maximum inrush current (20msec)**..... | 1.8amp |
| Output Circuit Configuration..... | N.O. triac switch |
| Temperature Range..... | -20°C to +70°C |

Mechanical Data

| | |
|---------------|-----------|
| Size: | |
| Length..... | 100mm |
| Diameter..... | 30mm |
| Thread..... | m30 x 1.5 |
| Weight: | |
| Plastic..... | .22Kg |
| Sleeved..... | .30Kg |

Mounting Requirements.....Observe Free Zone (See Figure 1)

Enclosure

- Plastic Housing (HC48921-).....Assembly 101, 102
 - Glass Filled Polyester (PBT)
 - UV Stabilized for Outdoor Use
- Nickel-Plated Sleeved Housing (HC48921-).....Assembly 151, 152
 - Brass Sleeve over Glass Filled Polyester (PBT)
 - UV Stabilized for Outdoor Use

NEMA 4X,13

CSA-LR12268

**E150 Specification

