

Lifting Magnet Controllers

4292P

Type 4292P Compact Controller for Scrap Yards

Specification/Price Sheet • January 2021, Replaces May 2010

YARDMASTER PUP



Description

The Type 4292P Yardmaster Pup Controllers incorporate heavy-duty time proven components arranged to provide optimum control of your lifting magnets. A mechanically rugged high thermal capacity discharge varistor assembly is permanently connected in parallel with the magnet and provides a safe discharge path for the stored magnetic energy. With Yardmaster Pup magnetic controllers induced voltage cannot return to the line, permitting rectified power supplies to be used without the added expense of special protective loads or bypass circuits.

Features

- Automatic Discharge
- Rated 5-50 amps DC
- Front-Wired, Front-Removable components
- Mechanically interlocked "Lift" and "Drop"
- NEMA rated mill duty contactors
- Permanently connected 700V discharge path completely independent from the line that protects magnet and generator
- High-Thermal capacity varistor discharge path
- Peak magnet induced voltage limited to under 700 volts
- Long electrical contact life
- Minimum maintenance
- Dribble control standard on 115V & 230V controllers
- Ventilated Indoor/Outdoor NEMA 3R Enclosure

Application

The Type 4292P Yardmaster Pup Controllers are suited for many uses from light to medium scrap handling applications. They may be used with all types and makes of DC lifting magnets.

Automatic Discharge Type Controllers

The Type 4292P Yardmaster Pup Automatic Discharge Type Lifting Magnet Controllers provide a fast and clean release of magnet loads by applying full voltage reverse current to the magnet. The full voltage reverse current feature permits the operator to promptly return for another lift.

The drop contactor is under the control of the operator's Master Switch and the Discharge Sensor Module (DSM). When the operator's Master Switch signals the magnet controller to drop the load, the Lift contactors (L) open. The stored magnet energy is dissipated in the discharge varistor. When the discharge voltage declines to approximately 300V, the DSM energizes the Drop Relay (DR) which in turn enables the Drop Contactor (D) to close applying full voltage reverse current to the magnet and begins the adjustable time reverse current cycle. After completion of the timed reverse current cycle, the drop relay and the drop contactor are de-energized.

WARDMASTER PUP

ELEMENTARY SCHEMATIC FOR 12 or 24 VDC PUSH BUTTON CONTROL

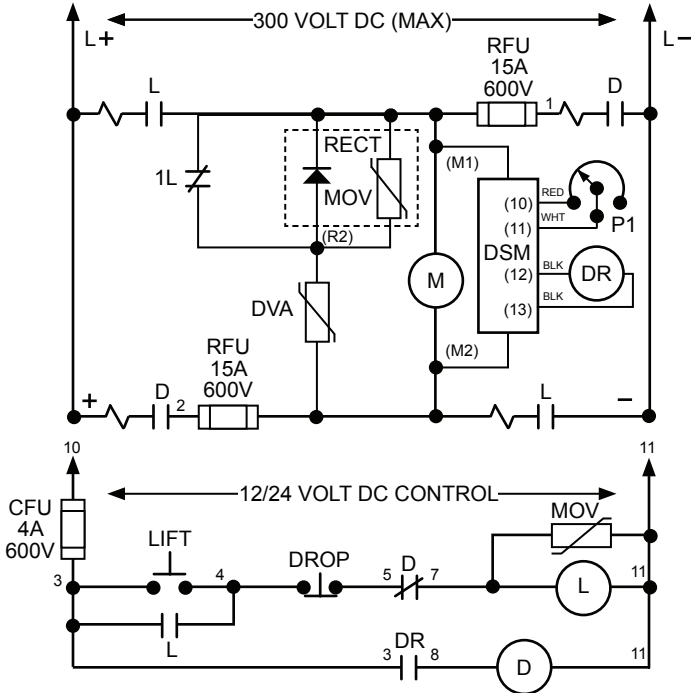

ELEMENTARY SCHEMATIC FOR 115 or 230 VDC MASTER SWITCH CONTROL

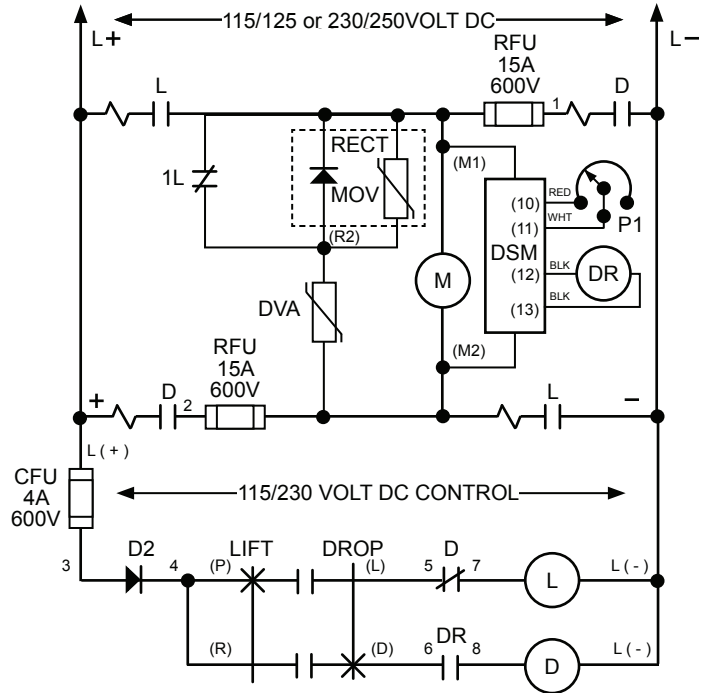

- DVA..... Discharge Varistor Assembly
- MOV..... Control Suppressor
- CFU..... Control Fuse
- RFU..... Drop Fuse
- RECT./MOV..... Rectifier / MOV Assembly
- P1..... Potentiometer Assembly
- DR..... Drop Relay
- DSM..... Discharge Sensor Module
- D..... Drop Contactor
- L..... Lift Contactor

- D2..... Diode
- DVA..... Discharge Varistor Assembly
- MOV..... Control Suppressor
- CFU..... Control Fuse
- RFU..... Drop Fuse
- RECT./MOV..... Rectifier / MOV Assembly
- P1..... Potentiometer Assembly
- DR..... Drop Relay
- DSM..... Discharge Sensor Module
- D..... Drop Contactor
- L..... Lift Contactor

Cabinet Dimensions

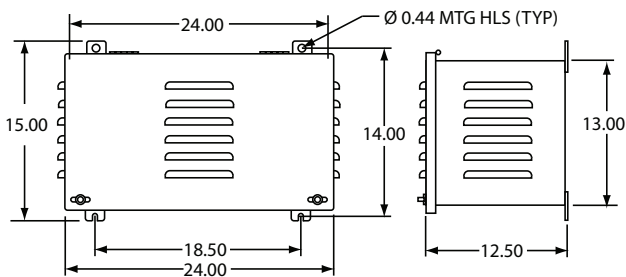

Approximate Shipping Weight 100 lbs.

Part Numbers and Prices

Part Number	Control Circuit Voltage	List Price
		Sch. KD
HC4292001301	24 VDC	\$14,700
HC4292001303	12 VDC	\$14,700
HC4292001305	230 VDC	\$14,700
HC4292001307	115 VDC	\$14,700
		Sch. ET
HCTA4215	Master Switch for 115/230 VDC Operation	\$1,350

Controller ampacity is based on being used with a 50% duty magnet in a 40° C ambient.



Hubbell Industrial Controls, Inc.
a subsidiary of Hubbell Incorporated
 4301 Cheyenne Drive, Archdale, NC 27263
 Phone (336) 434-2800 · Fax (336) 434-2803
 www.hubbell.com/hubbellindustrialcontrols/en
 sales@hubbell-icd.com