



WILEY

PRODUCT GUIDE

Wire Management

A complete guide to wire management solutions for the solar professional





Manchester New Hampshire BURNDY Headquarters

History of Wiley

Founded in 2005, Wiley quickly became a go-to name for high quality solutions and products that fit the needs of an ever-evolving solar market. With consistent growth and products that earned the trust of the most seasoned installers, Wiley joined forces with BURNDY, LLC in 2011 to increase the reach of products and match the rapid growth of solar seen across the world. The combined resources of two engineering companies have allowed both Wiley and BURNDY to continue a tradition of matching industry needs with the best engineered products available in the market.

About the Guide

This guide is intended to provide an in-depth understanding of current best practices related to managing wires integral to a successful solar installation. Starting with an overview of product types including the advantages of each wire management strategy, industry professionals will recognize opportunities to apply a wide variety of products to create the optimal solution for any installation. Different commercial and utility systems are then examined with suggestions on product types and installation guidelines as recommended by our team of seasoned engineers.

Following sections on wire management types and installation recommendations, a review of product and material testing shows the rigorous evaluation process Wiley products are tested to. Our focus on testing our products to vigorous scenarios to hold up in the most challenging installations is one of the key reasons Wiley products are trusted to last in the harshest of environments.

Why Wire Management?

Beyond being required by the National Electrical Code (NEC), proper wire management is essential to ensure longevity of an installation and prevent premature failure that can lead to system downtime and even fire. Wires must be properly routed, organized, supported, and protected so that they can endure harsh environments typical of solar installations. Proper wire management addresses the following concerns:

- Prevents damage to wire insulation that can lead to ground-faults, system downtime, and fire.
- Proper wire management reduces maintenance and repair requirements over the lifetime of the PV system.
- Secured wires reduce probability of access for rodents and other critters with habits of chewing through wire insulation.
- Installations with quality wire management are cleaner and more aesthetically pleasing.

Table of Contents

History of Wiley	2	Cable Ties and Straps	12
About the Guide	2	Nylon 6/6 Ties	12
Best Practices	4	Nylon 12 Ties	12
Standards and Requirements	5	Stainless Steel Ties	12
Types of Wire Management	6	Bundle Straps	13
Material Selection	7	Reusable Coated Straps	13
Nylon 6/6	7	P-Clips	13
Nylon 12	7	Cable Hangers	14
400 Series Stainless Steel	7	Cable Hangers & Fuse Holders	14
304 Stainless Steel	7	Installation Recommendations	15
Galvanized Steel	7	Commercial/Fixed Tilt Systems	
Cable Clips	8	Landscape Orientation	16
Straight On	8	Portrait Orientation	17
Straight On and 90°	9	Wire Management Layouts	
90°	9	Fixed Tilt Landscape	18
Straight On and 180°	10	Fixed Tilt Portrait	18
90° and 180°	10	Wire Management Layouts	
Rail Clips	10	Portrait Orientation Option 1	19
Mounting Bases	11	Portrait Orientation Option 2	20
Stainless Steel	11	Utility Scale/Tracker Systems	
Pre-Assembled	11	Portrait Orientation Option 1	21
		Portrait Orientation Option 2	21
		Environmental Considerations in Wire Management	
		(White Paper)	22
		Quick Reference Guide	26



Best Practices

The following list of best practices contain general rules of thumb that should be considered when designing a wire management system. Although every installation is unique, adherence to these guidelines will promote system longevity by protecting wires from premature failure due to environmental factors that can be avoided.

- Keep all materials out of direct sunlight whenever possible. Even UV resistant materials will have a longer lifespan when they can be installed in partially shaded locations such as tucked under a module.
- Quality UV-rated plastic products and stainless steel cable clips are the best solutions available. Plastic products will deteriorate over time while stainless steel products have the best longevity.
- Secure wires at intervals according to the NEC. It is recommended to use at least one clip or other securement point per module.
- Keep cables tucked up and away from potential hazards. This reduces the risk of UV degradation, rodent chewing damage, and harm caused by abrasive materials such as roof tiles or sharp edges.
- Always refer to any manufacturer's installation instructions for proper install methods and product compatibility information.
- Remember that ongoing operation and maintenance is necessary in all exterior wiring systems - regardless of materials or products used.



Similar to most aspects of an installation, there exist codes and standards that define requirements for wire management products. These requirements are essential for products to meet compatibility with defined applications and to ensure the safety of an installation. This is viewed as so important that the NEC specifically states that products must be listed for their intended application. The two main standards that wire management products may be listed to include UL 1565 and UL 62275.

UL 1565 is the standard that covers positioning devices used in wire management to support cable, wire, or conduit.

UL 62275 is the standard that covers cable ties and cable tie accessories such as mounting bases or other assemblies.

Each of the standards listed above subject parts to rigorous testing sequences that simulate the harshest of conditions an installer is likely to encounter in the field.

Parts are investigated from a variety of aspects spanning from strength ratings to flame resistance. Wiley ensures all parts meet standard requirements to give our customers peace of mind that they are using some of the highest quality components available in the marketplace.



Types of Wire Management

Wiley recognizes the unique features of every installation and has the ability to offer products for almost all applications. With a product offering ranged from cable clips and mounting bases through cable ties, straps, hangers, and P-clips, the most challenging installations are simplified with engineered solutions. For applications that fall outside the bounds of this guide, our team of engineers stands ready to assist in product selection or with the design of a customized solution. Whatever your wire management application, Wiley has the engineering expertise and industry knowledge to assist.



Edge clips and cable ties allow for routing bundles of wires parallel or perpendicular to the frame or rail on which they are mounted.



Cable clips mount to frame or rail flanges and come in configurations that allow for different bundle sizes and mounting orientations.



Hardware mounted bases and coated P-clips come in a variety of sizes and can be used to support anything from cables to conduit.



Rail clips are designed to install onto the mounting structure and can route multiple cables along different rail geometries.

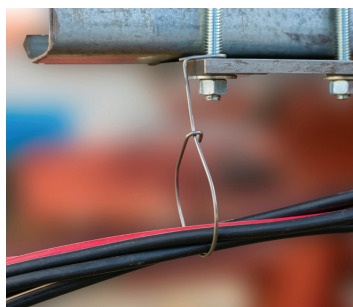

Cable Hangers can support large bundles of cables and protect cable insulation from damage.

Wiley offers a wide range of wire management products with new uses and applications developed daily. Our engineering team is constantly working on new products that make PV installation simpler, more efficient, and longer lasting.

When considering solutions for each application, one of the most important factors is material selection. The material that a product is manufactured from or comprised of can be the difference between a temporary product intended to last a couple of years and a long-term solution being able to endure harsh environments for decades. The BURNDY and Wiley product portfolio is made up of products made from different grades of material so that there is an optimal solution for all environments and intended product lifespans.

The five major material categories include: Nylon 6/6, Nylon 12, 400 Series Stainless Steel, 304 Stainless Steel and Galvanized Steel.

Nylon 6/6

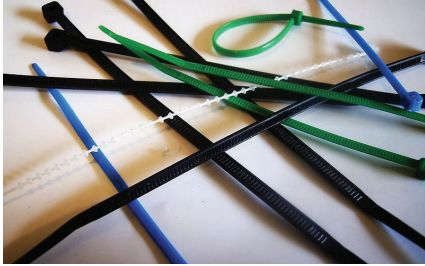

UV resistant, heat stabilized nylon 6/6 material is available as an option in various plastic products including cable ties and edge clip products. When compared to standard nylon 6/6 material, the UV resistant and heat stabilized version is a minimum requirement for outdoor applications with exposure to sunlight and moisture. While this material will still absorb moisture and eventually degrade based on UV light and embrittlement, the additives used prevent the rapid advancement of degradation that occurs in unrated cable ties. UV resistant, heat stabilized nylon 6/6 products are the answer for applications requiring an economical solution with moderate resistance to environmental factors.

Nylon 12



UV resistant nylon 12 material is offered as a high-end option for most plastic products. The polymer structure and orientation of nylon 12 gives the material a much higher resistance to moisture absorption and a higher impact resistance when compared to nylon 6 or nylon 6/6. The reduced susceptibility to moisture absorption decreases the effects of embrittlement and significantly extends the service life of products made from nylon 12.

400 Series Stainless Steel



Stainless steel is often looked at as an alternative to plastic that is guaranteed to last the life of an installation. While this may be the case for some types of stainless, the grade that a product is made from can have significant impact on product longevity in corrosive environments. 400 series stainless steel products are a good choice when corrosion is not a concern, such as indoor and substantially inert environments. They are also a good choice for temporary applications where long-term stability and corrosion resistance are not key factors in product success.

304 Stainless Steel



304 stainless steel, used in Wiley products, is a great alternative to 400 series products when they are to be installed in conditions that can lead to corrosion. Significant testing has shown that 304 stainless steel has superior corrosion resistance and has the ability to endure harsh conditions seen in the most difficult solar installations. Product manufactured from 304 stainless steel are the optimal choice for installation critical wire management intended to last the life of a system in harsh environmental conditions.

Galvanized Steel



Galvanized steel, offered as an option for Wiley's cable hanger line, is a less expensive and more ductile option to the stainless steel version. It also does well against corrosion, vibration, weathering, and temperature extremes but to a lesser degree than stainless. The increased ductility allows for easier workability and installation. Recommended for above ground use only.

Cable Clips





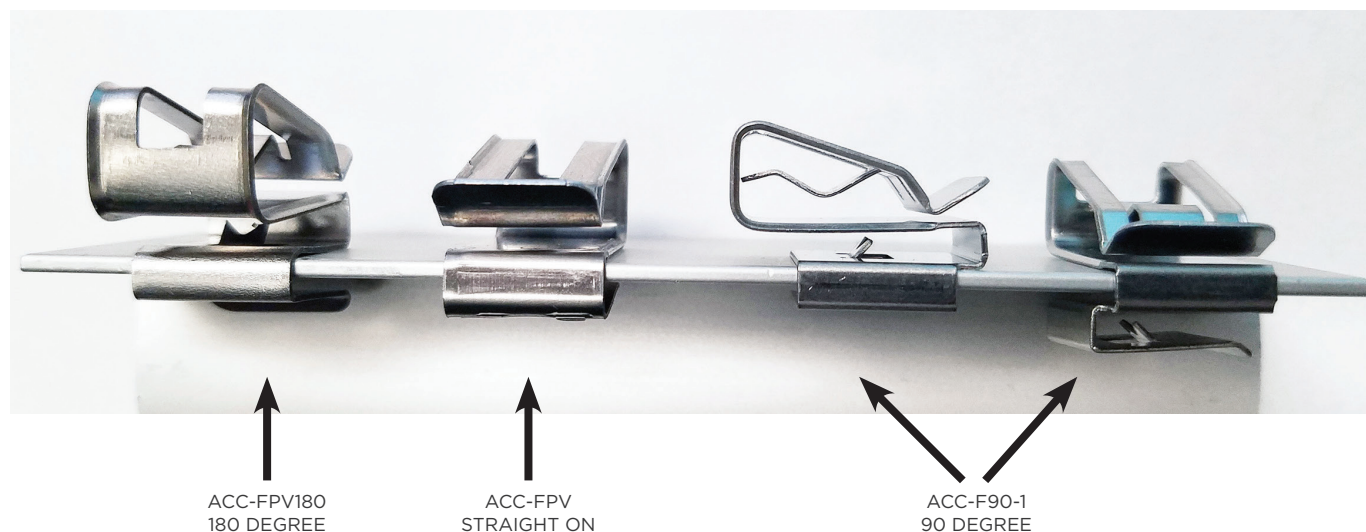

Wiley cable clips are made of corrosion resistant 304 stainless steel, which makes them a durable, long-lasting and reliable solution for all environments. Innovative clip designs allow for quick and easy installations that do not require the use of any tools. With flexibility to accommodate most wires used in the solar industry, Wiley cable clips are designed with rolled edges to prevent damage to insulation. With listings to UL1565, installers can be confident Wiley products will get the job done right.

To accommodate for the individual attributes of each unique installation, Wiley has engineered cable clips to work in all applications. With offerings of straight on, 90°, and 180° cable clips, Wiley has the solution to meet your needs.

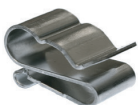







Straight On

Straight on clips are designed to be used where wires are intended to run parallel with the flange onto which the clips are installed. This is common when wires are routed along the top or bottom flange of a row of modules installed in portrait orientation.

Part Image	Catalog Number	Application	UL Listing	Catalog
	ACC	1 to 2 USE-2 cables or 1 PV Cable Wire Diameter Range: 4.1mm - 5.5mm per each cable Flange Thickness Range: 1.3mm - 2.5mm	UL1565	
	ACC-PV	1 to 2 USE-2 cables or 1 PV Cable Wire Diameter Range: 4.1mm - 7.0mm per each cable Flange Thickness Range: 1.3mm - 2.5mm	UL1565	
	ACC-FPV	1 to 2 PV Cables Wire Diameter Range: 5.0mm - 8.0mm per each cable Flange Thickness Range: 1.3mm - 3.0mm	UL1565	







Straight On and 90°

Straight on and 90° clips give installers the flexibility to install clips in orientations where wires are routed parallel or perpendicular to the flange onto which the clip is secured. Straight on orientations are generally used when wires are routed along the top or bottom module flange and the 90° orientation can be used to secure wires running along the middle of a row of modules.

Part Image	Catalog Number	Application	UL Listing	Catalog
	ACC-F90-1	1 to 2 PV Cables Wire Diameter Range: 4.1mm - 7.1mm per cable Flange Thickness Range: 1.3mm - 2.5mm	UL1565	
	ACC-F2-90	1 to 2 PV Cables Wire Diameter Range: 6.2mm - 8.0mm per cable (2 cables) 6.2mm - 14.0mm per cable (1 cable) Flange Thickness Range: 1.3mm - 2.5mm	UL1565	
	ACC-F4-90-1	1 to 4 PV Cables Wire Diameter Range: 4.1mm - 6.7mm per cable Flange Thickness Range: 1.3mm - 2.5mm	UL1565	

90°





90° clips are designed for use in applications where wires need to be secured in a perpendicular orientation with relation to the flange onto which the clips are secured. This is seen in applications where a bundle of wires runs along the center of a row of modules installed either in portrait or landscape orientation.

Part Image	Catalog Number	Application	UL Listing	Catalog
	ACC-FPV90	1 to 2 PV Cables Wire Diameter Range: 5.0mm - 8.0mm per cable Flange Thickness Range: 1.0mm - 3.0mm	UL1565	
	ACC-F490	1 to 4 PV Cables Wire Diameter Range: 5.0mm - 8.0mm per cable Flange Thickness Range: 1.0mm - 3.0mm	UL1565	
	ACC-F4F	1 to 4 PV Cables Wire Diameter Range: 5.0mm - 8.0mm per cable Flange Thickness Range: 1.0mm - 3.0mm	UL1565	

Cable Clips



Straight On and 180°

Straight on and 180° clips have the same functionality and application of straight on clips with the added flexibility of determining which direction is best for the wire opening. This style clip is used in applications where there can be high vibration or movement and opposing clips secure wires with openings pointed in opposite directions.

Part Image	Catalog Number	Application	UL Listing	Catalog
	ACC-FPV180	1 to 2 PV Cables Wire Diameter Range: 5.0mm - 8.0mm per cable Flange Thickness Range: 1.0mm - 3.0mm	UL1565	
	ACC-FF180	1 to 2 PV Cables Wire Diameter Range: 5.0mm - 8.0mm per cable Flange Thickness Range: 1.0mm - 3.0mm Flange Width: Down to 12.0mm	UL1565	







90° and 180°

90° and 180° clips give similar flexibility in installation orientation as the straight on and 90° clips. The application difference with this style clip is that the wire opening is oriented to face the flange onto which the clip is installed.

Part Image	Catalog Number	Application	UL Listing	Catalog
	ACC-F1-270	1 to 2 PV Cables Micro Inverter Trunk or AC cables Wire Diameter Range: Max. 13.0mm in total Flange Thickness Range: 1.3mm - 2.5mm	UL1565	

Rail Clips

Rail clips are designed to install onto rail channels common to the supporting structures used in most installations. These clips route wire securely along the path of a rail structure and are intended to be used for home run or other similar applications.

Part Image	Catalog Number	Application	UL Listing	Catalog
	ACC-R2	1 to 2 PV Cables Micro Inverter Trunk or AC cables Wire Diameter Range: 4.1mm - 8.0mm per cable (2 cables) 4.1mm - 14.0mm per each cable (1 cable) Racking: Unirac, Ironridge, or similar rack profiles	UL1565	
	ACC-R4	1 to 2 PV Cables Micro Inverter Trunk or AC cables Wire Diameter Range: 4.1mm - 6.5mm per cable Racking: Unirac, Ironridge, or similar rack profiles	UL1565	
	ACC-RBC15	Bundle of PV Cables Micro Inverter Trunk or AC cables Wire Diameter Range: Max. 15mm in total Rail Channel or Slot Width: 6.35mm - 13.5mm	UL1565	



Mounting Bases

For the ultimate installation flexibility, mounting bases provide installers with a single solution to meet the needs of almost any application. Mounting bases slide onto common flange sizes to provide a location to route ties or straps capable of securing bundles of any size. Constructed of nylon 6/6, nylon 12, or 304 stainless steel, mounting bases are designed to meet varying longevity and price requirements.

With rolled edges and multiple tie routing orientations, the stainless steel mounting base accepts most common cable ties and straps. Plastic mounting bases incorporate steel teeth that bite and hold onto common flanges and come pre-assembled with a cable tie in your chosen orientation.

Stainless Steel

Stainless steel mounting bases give installers flexibility to mount their chosen bundle strap onto common flange sizes. Openings are available in parallel and perpendicular orientations and can accommodate most cable ties and straps described in the following section.

Part Image	Catalog Number	Application	UL Listing	Catalog
	ACC-FBC	Allows a cable tie to be routed in both landscape (on the horizontal portion of module frame) and portrait (on the vertical portion of module frame) orientations. Max Cable Tie Width: 8mm Flange Thickness Range: 1.3mm - 3.0mm	UL1565	

Pre-Assembled

The pre-assembled mounting base options come with the bundle tie installed onto the flange securement member. With flexibility in length, parallel or perpendicular orientation, availability in both nylon 6/6 and nylon 12, and two sizes to accommodate different flange ranges, there is a pre-assembled mounting base/tie combination for almost any application.

Catalog Number	Flange Size	Catalog Number	Flange Size	Style	
ACC-ECTA68	1.3mm - 3.0mm	ACC-ECTWA68	3.0mm - 6.0mm	A	
ACC-ECTA611		ACC-ECTWA611			
ACC-ECTA614		ACC-ECTWA614			
ACC-ECTA128		ACC-ECTWA128			
ACC-ECTA1211		ACC-ECTWA1211			
ACC-ECTA1214		ACC-ECTWA1214			
ACC-ECTB68				ACC-ECTWB68	B
ACC-ECTB611				ACC-ECTWB611	
ACC-ECTB614				ACC-ECTWB614	
ACC-ECTB128				ACC-ECTWB128	
ACC-ECTB1211				ACC-ECTWB1211	
ACC-ECTB1214				ACC-ECTWB1214	





Cable Ties and Straps

With a wide range of fastening ties and straps, Wiley and BURNDY can match the performance of each product to the specifications and requirements of the installation. From nylon 6/6 and nylon 12 cable ties to stainless steel ties and coated products, designs are engineered to install quickly and endure the harsh environmental conditions seen in the field.

Nylon ties are constructed of UV resistant material with nylon 12 providing additional longevity based on increased resistance to moisture absorption and embrittlement. Stainless steel ties are proven as corrosion resistant solutions and are available in uncoated, partially coated, and fully coated versions. Bundle straps consist of a stainless steel wire coated in a vinyl jacket designed to protect cable insulation and can be installed with quick and easy crimping utilizing linesman pliers or standard wire cutters. Reusable coated straps can be taken on and off of an installation numerous times and are designed to endure harsh conditions. Constructed of a steel interior and then double coated, these products are tested to stand the test of time.



Nylon 6/6 Ties

Nylon 6/6 ties come in a variety of lengths and strength ratings. Providing flexibility in installation requirements, standard cable ties can be used with almost any module and racking system.

Part Image	Catalog Series	Application	UL Listing	Catalog
	Nylon 6/6 Cable Tie (CT)	For bundles of cable - UV resistant Nylon 6/6 and 2% UV Black Nylon 6 Mil. Spec Available lengths: 7.6" to 18" Tensile Strength: 50 lbs	UL62275	



Nylon 12 Ties

Nylon 12 ties come in a variety of lengths and strength ratings with the added benefit of being manufactured from a more resilient material. Proving flexibility in installation requirements, cables ties can be used with almost any module and racking system.

Part Image	Catalog Series	Application	UL Listing	Catalog
	Nylon 12 Cable Tie (CTNT)	For bundles of cable - UV resistant Nylon 12 Available lengths: 8" to 18" Tensile Strength: 50 lbs	UL62275	



Stainless Steel Ties

Stainless steel ties are intended to be used in applications where longevity is essential, and the environments are highly corrosive. They can also add additional strength where larger bundles are required to be routed.

Part Image	Catalog Series	Application	UL Listing	Catalog
	Stainless Steel (CTSS, CTSS-PC, and CTSS-FC)	For bundles of cable - 304 or 316 Stainless Steel Polyester coated, Partially coated, and Uncoated Available lengths: 8" to 18" Tensile Strength: 50 lbs	UL62275	



Bundle Straps

Coated bundle straps combine the longevity of stainless steel cable ties with additional flexibility in mounting locations. The coated steel strap can be routed through mounting and grounding holes and the securement tab provides a “third hand” during installation prior to crimping with standard pliers.

Part Image	Catalog Series	Application	UL Listing	Catalog
	WBS	For bundles of cable - easy to install and can be crimped in the field with electrician linesman pliers or standard wire cutters. 304 stainless steel wire with UV-rated vinyl jacketing Available lengths: 8" to 36" Tensile Strength: 100 lbs	UL62275	



Twist Straps

The innovative Wiley Twist Strap (WTS) provides a quick, dependable wire management solution. As easy to use as a cable tie, while offering the durability of a bundle strap. NO tools are required—the WTS makes securing, readjusting, and removing fast and effortless. To use, just insert the stem into the twisted eye loop and fold over. Reusable. Saves both material and labor costs!

Part Image	Catalog Series	Application	UL Listing	Catalog
	WTS	For bundles or securement of cables. Stainless steel core with UV resistant PVC coating. Available lengths: 8" to 36" Tensile Strength: 40 lbs.	UL1565 and 2239	

Coated P-Clips

Wiley coated P-clips are designed to be a secure attachment point while protecting cables from insulation damage that can occur as a result of vibration or wire movement. Mounted with installation hardware, P-clips are an optimal solution for bundles of wire and high strength applications. Available in a variety of sizes, coated P-clips can accommodate bundle diameters ranging from 1/4" to 3".

Part Image	Catalog Series	Application	UL Listing	Catalog
	WIPC	For single cables or bundles - coated p-clips easily install into a mounting hole with 1/4" hardware. Coating protects cables from vibration and insulation damage. UV-resistant vinyl, zinc-plated steel (304 stainless steel available upon request) Available Bundle Diameters: 0.25" to 3"	UL1565	

Cable Hangers









Cable Hangers

The WILEY Cable Hanger family is designed to support cables via module mounting or wire management holes or around a tracker bolt secured at the tracker level. The WCH1 and WCH2 models are compatible with all common module frame geometries including First Solar Series 6.

The WCHP2 features a unique “pinch” installation and fits into both module holes as well as can be used in conjunction with the ACC-FBC for use anywhere along the module frame. In addition, it is an excellent solution for the First Solar Series 7 modules.



WCH2B10, WCH2H1090, WCH2-90-15 and ATI series hangers are set at a 90° angle aligning with the torque tube thus ideal for use with bi-facial panels. With its closed loop design, the WCH2-90-15 also gives added flexibility to be installed at the module level.

All hangers are offered in either stainless or galvanized steel construction, both provide a solution made to last. The round bundle compartment ensures the cable insulation is protected from chafing and securely holds runs of up to 8 or 20 wires up to 8mm in diameter without allowing significant shifting from tracker movement or high wind.

Part Image	Catalog Number	Application	UL Listing	Catalog
	WCH1 / WCH1GS WCH2 / WCH2GS	Application via Module Mounting or Wire Management Hole. 300 Series – high tensile stainless or galvanized steel. Bundle diameters up to 2”	UL1565	
	WCH2B10 / WCH2B10GS	Application via Tracker System Bracket Bolt (FTC/Game Change or Similar) 300 Series – high tensile stainless or galvanized steel. Bundle diameters up to 2”		
	WCH2H1090 / WCH2H1090GS	Application via Tracker System Bracket Bolt (NexTracker Strap Version or similar) 300 Series – high tensile stainless or galvanized steel. Bundle diameters up to 2”		
	WCH15ATI / WCH15ATIGS	Installs on ATI Bracket 300 Series – high tensile stainless or galvanized steel. Bundle diameters up to 1.5”		
	WCH2-90-15 / WCH2-90-15GS	Installs in module wire management holes or on NextTracker’s Strap Bracket bolt or U Bracket bolt. 300 Series – high tensile stainless or galvanized steel. Bundle diameters up to 2”		
	WCHP2 / WCHP2GS	Installs in module wire management holes or anywhere on module frame when used with ACC-FBC clip. 300 Series – high tensile stainless or galvanized steel. Bundle diameters up to 2”		
	WCHJ-30HH / WCHJ-30HHGS	For use with First Solar Series 7 panels installed on NextTracker system. Installs in adjoining Series 7 module wire management holes.		

Fuse Holders

Secure module connectors and over molded fuses with Wiley’s fuse holders. Fuses snap into the hanger cradle and are easily “pinch” installed into wire management or mounting holes or into our ACC-FBC mounting clip.

Part Image	Catalog Number	Application	UL Listing	Catalog
	WFHP085 / WFHP085GS WFHP115 / WFHP115GS	Installs in module wire management holes or anywhere on module frame when used with ACC-FBM clip. Supports MC4 connectors (.085” diameter) and over molded fuses (1.15” diameter).	UL1565	

The following section of this guide gives an overview of installation recommendations for which wire management solutions can be used in different categories of applications. Commercial and fixed tilt systems are reviewed in addition to utility scale and tracker applications. Each set of recommendations provides multiple solutions that can be used in the application, but it is not the intention to suggest using every solution in a single installation.



BURNDY recommends that sufficient details of installation be submitted to the AHJ for approval before any work is started.

Commercial/Fixed Tilt Systems

Landscape Orientation

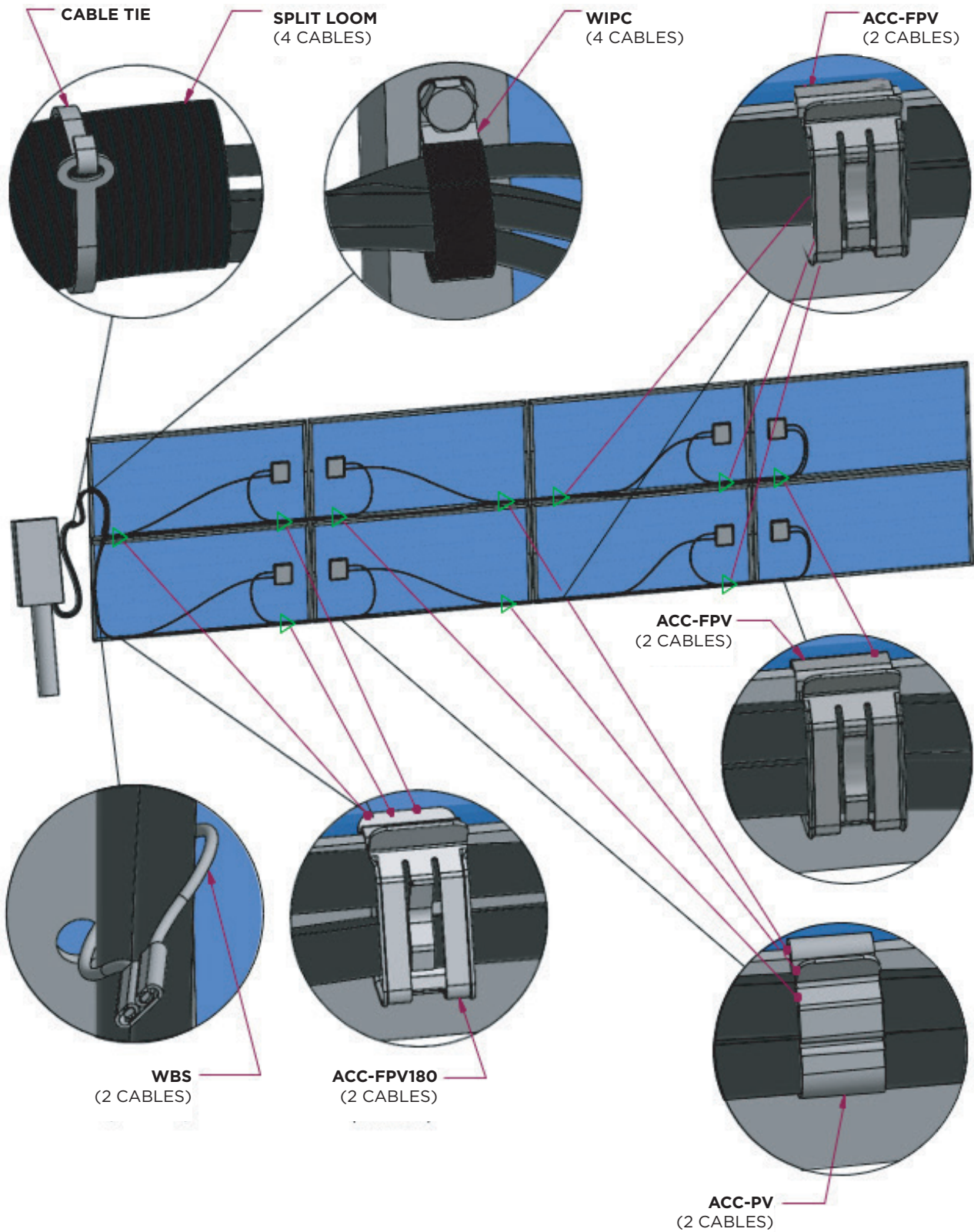

Portrait Orientation

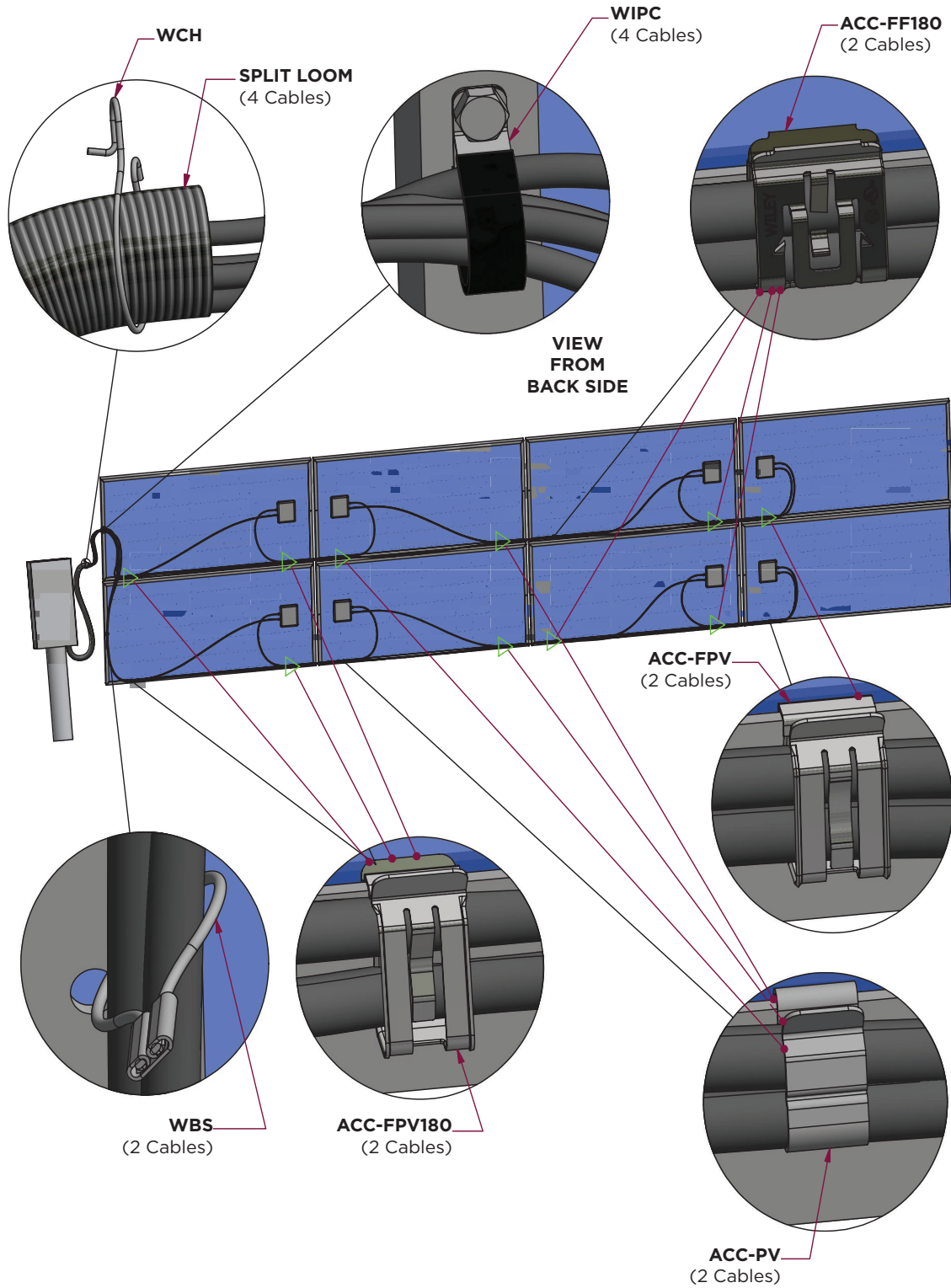

WILEY WIRE MANAGEMENT GUIDE

Wire Management Layouts

Fixed Tilt Landscape

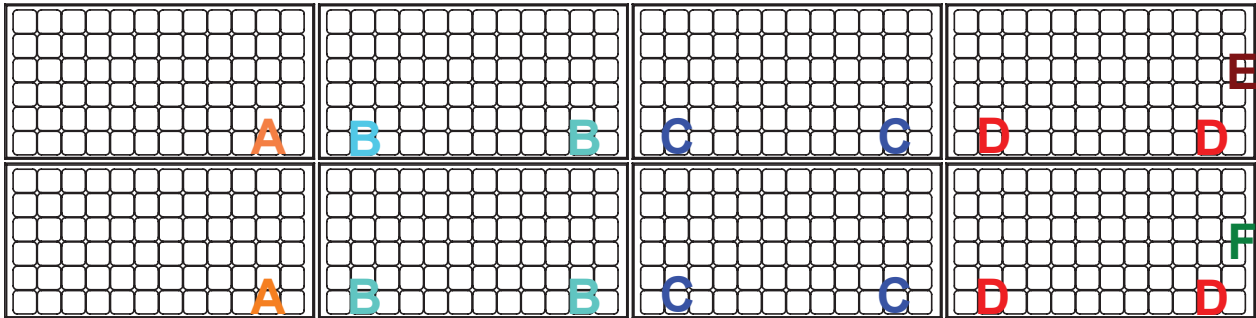

- A** PLACES TO INSTALL ACC-FPV
- B** PLACES TO INSTALL ACC-FF180
- C** PLACES TO INSTALL ACC-PV
- D** PLACES TO INSTALL ACC-FPV180
- E** PLACE TO INSTALL WIPC
- F** PLACE TO INSTALL WCH / WBS

Fixed Tilt Portrait

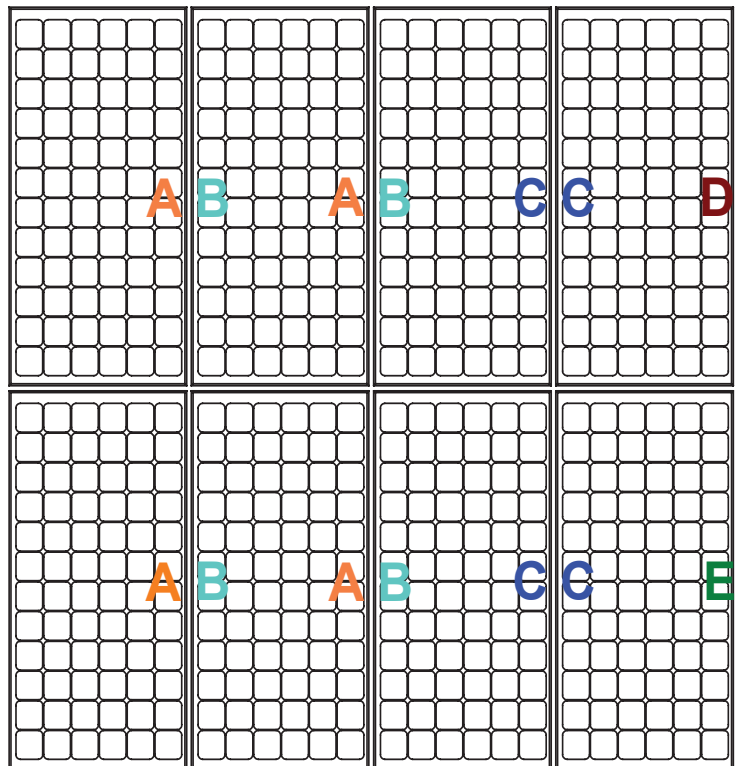

- A** PLACES TO INSTALL ACC-F90-1
- B** PLACES TO INSTALL ACC-FPV90
- C** PLACES TO INSTALL ACC-FBC WITH WBS
- D** PLACE TO INSTALL WIPC
- E** PLACE TO INSTALL WCH / WBS

Portrait Orientation Option 1

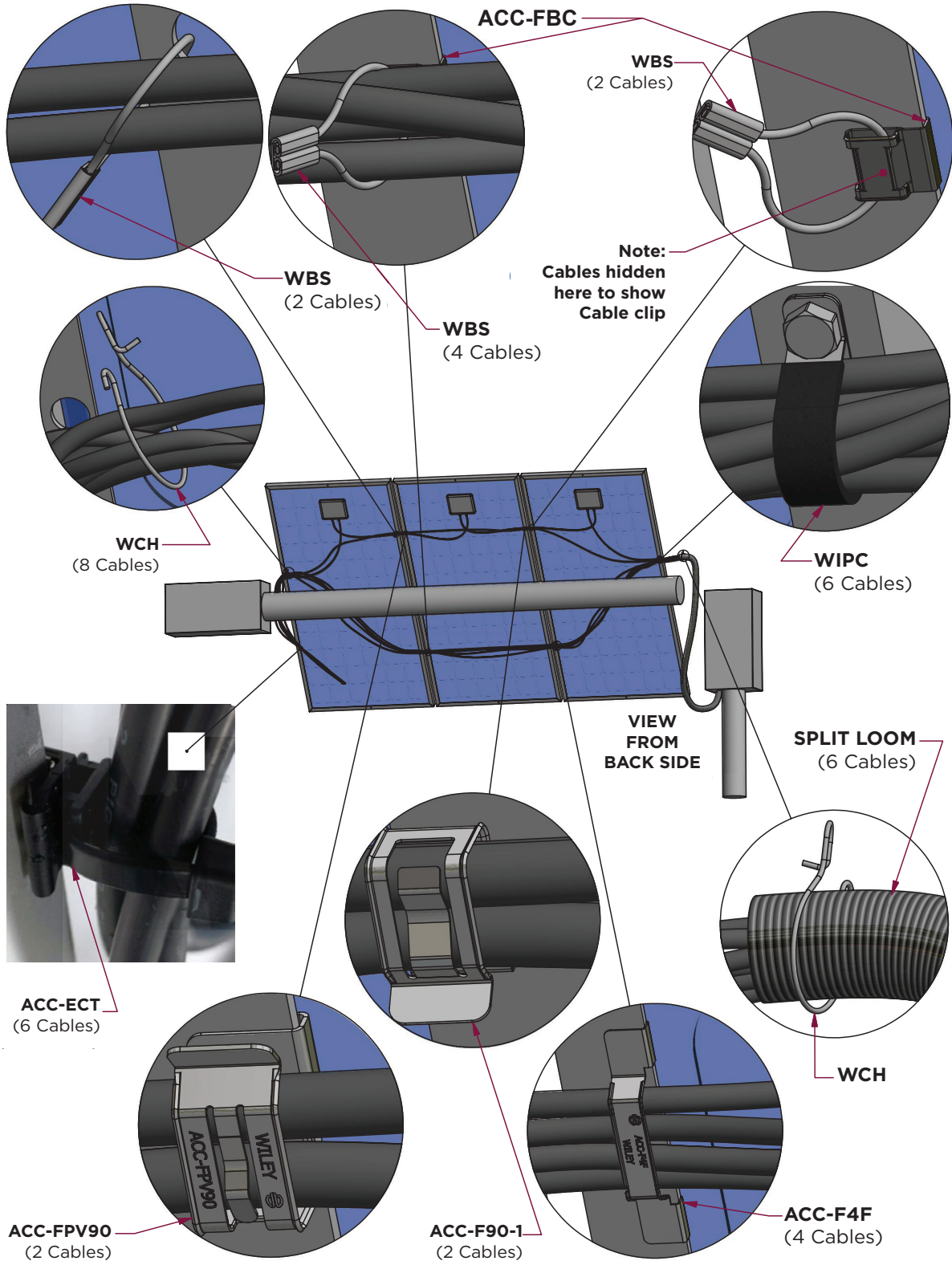

WILEY WIRE MANAGEMENT GUIDE
Utility Scale/Tracker Systems

Portrait Orientation Option 2

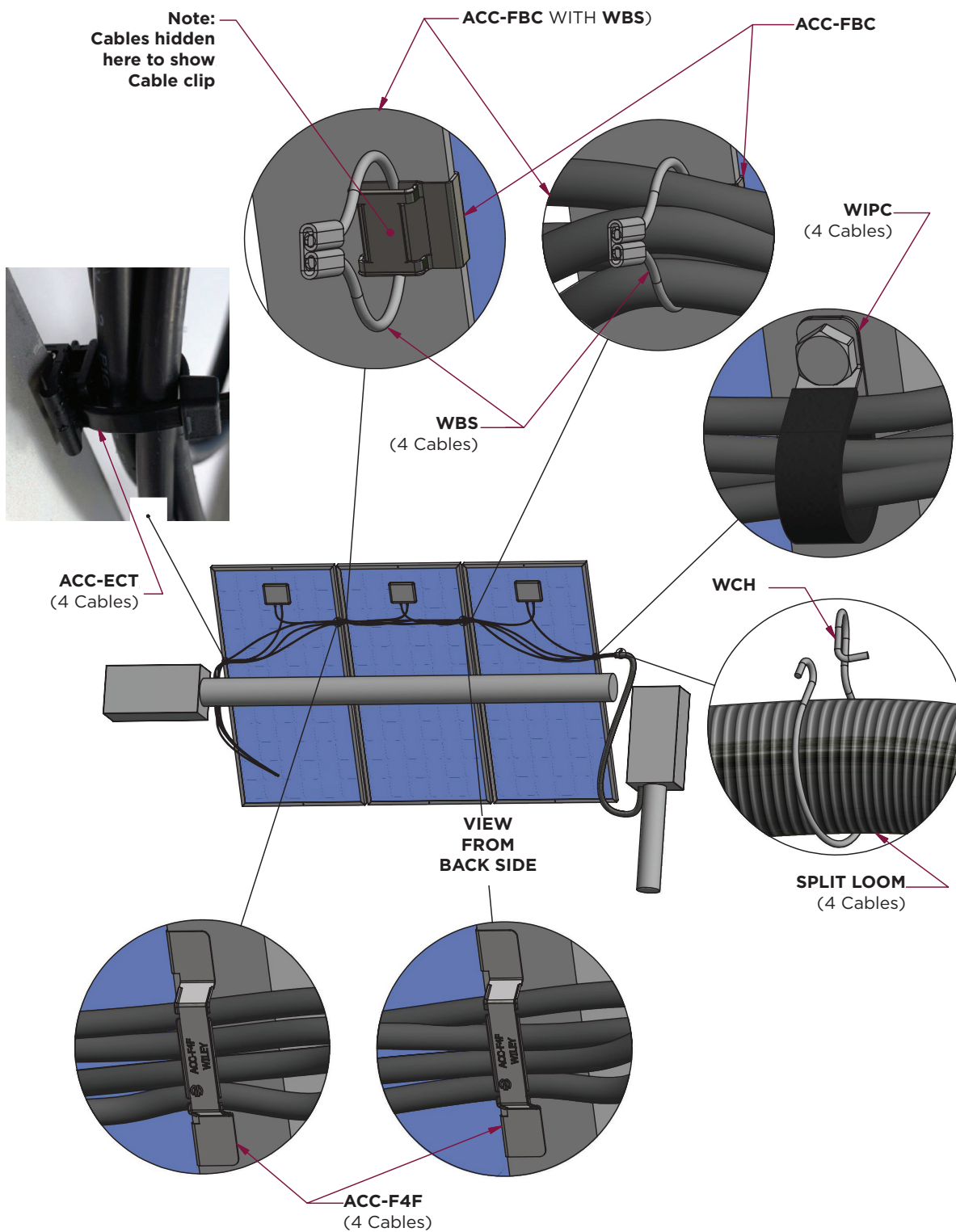

Portrait Orientation Option 1

- A** PLACES TO INSTALL ACC-FBC WITH WBS
- B** PLACES TO INSTALL ACC-F90-1
- C** PLACES TO INSTALL ACC-FPV90
- D** PLACES TO INSTALL WBS
- E** PLACE TO INSTALL ACC-F4F
- F** PLACE TO INSTALL WIPC
- G** PLACE TO INSTALL WCH

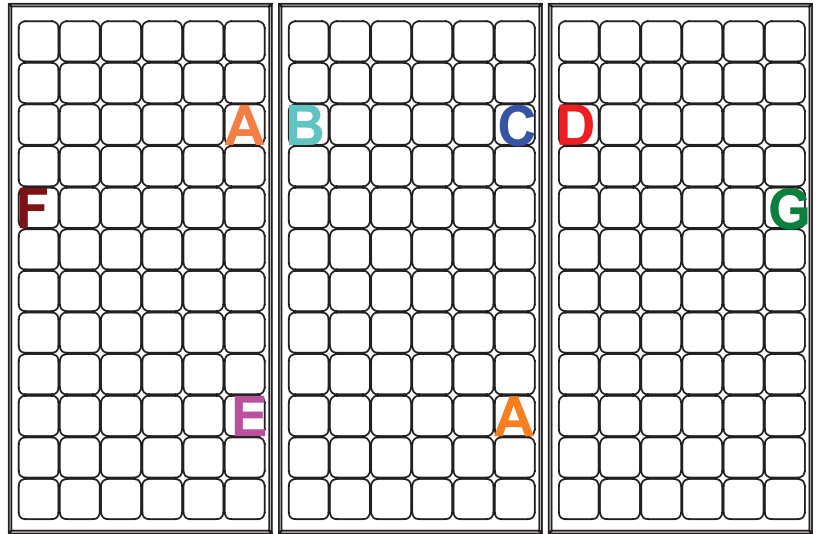

Portrait Orientation Option 2

- A** PLACES TO INSTALL ACC-FBC WITH WBS
- B** PLACES TO INSTALL ACC-F4F
- C** PLACES TO INSTALL WIPC
- D** PLACES TO INSTALL WCH

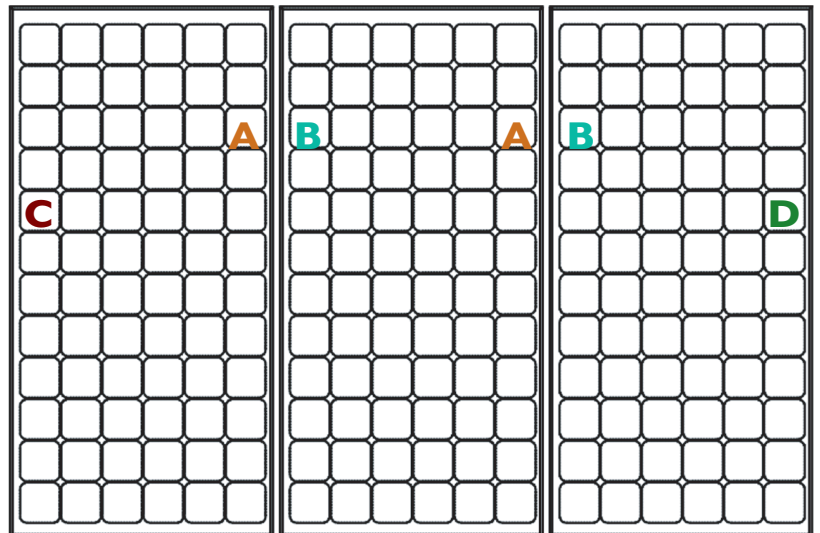

Environmental Considerations in Wire Management

A study on the importance of variable environmental conditions in material validation.

Abstract

As the conversation around wire management gains more and more momentum in the solar industry and new options for wire management products are introduced on a daily basis, a need for validating quality materials has become essential. This study first examines the importance of high quality solutions along with current methods used for evaluating products before an innovative approach to validate materials is presented. This new method exposes materials to various environmental stresses over an accelerated evaluation period while products are examined for degradation at regular intervals. The results show that variable environmental stresses are important to examine when qualifying materials and products for use in harsh environments with variable environmental conditions.

Introduction

While the industry has come a long way in understanding the role that corrosion plays in determining the lifespan of solar installations, there is still room for improvement in predicting how components will react to the variable environmental conditions of the real world.

Before diving into the factors that can cause failures of components intended to ensure a lasting installation, it is important that one understands the vital role that wire management solutions play. Wire management solutions can be used to support and protect cables from potential damage due to sources such as abrasion or animals. Not only is an orderly installation required by the National Electric Code, but properly supporting cables at regular intervals with products that stand up to the test of time can save money in Operation and Maintenance (O&M) work and dealing with system failures.

Importance of Lasting Solutions

The NEC outlines the limited distances between which cables can span without support or securement mechanisms in Article 690.31. This requirement is important so that the wires critical to system performance are able to endure the harsh environments for the expected lifespan of the installation.

Without proper wire management or with solutions that do not last in the variable outdoor environment, damaged wire insulation can lead to ground faults, system downtime and even fire. Lasting solutions reduce maintenance costs and keep the installation organized with wires out of reach of rodents or other animals known for chewing and damaging wires. The legal requirements of the NEC stem from these issues seen in the field prior to the industry wide understanding of the importance of wire management.

As developments are made in wire management products and solutions are available at cheaper and cheaper price points, installers and owners of PV systems must be sure to understand the implications of product selection. As noted previously, it is common to have testing or certification requirements for products that give some insight into how the solution will react to corrosive forces in the environment.

It is rare for this testing to come in a form other than salt spray testing, often completed to a standard defined in ASTM B117. While this test does give clues as to how a product will stand up to corrosive environments, the condition that a product is exposed to is limited to a steady corrosive environment. Salt spray is a good baseline to determine how one product will last compared to a similar product in an outdoor, corrosive environment, but it does not give any information on how products will react to additional stressors in a real-world installation.

Failures in the field have shown that material degradation can occur from environmental conditions other than a salty or corrosive atmosphere. A combination of environmental conditions can build upon the degradation seen from salt spray and accelerate the time to failure of certain materials.

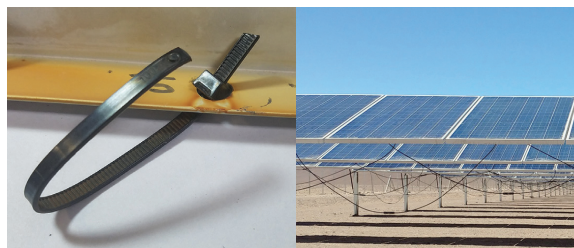
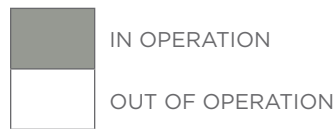

Figure 1 - Unsupported Wire Due to Tie Failure

HUMIDIFICATION													
HEATING													
DEMINERALIZED RAIN													
SALT FOG													
SOLAR RADIATION													
	2	4	6	8	10	12	14	16	18	20	22	24	

Figure 2 - 24 Hour Cycle per IEC 61109



For example, many polymers will hold up well to salt spray testing but can degrade rapidly through UV stress or absorption of moisture with humidity. Failure of polymer cable ties led to the unsupported wiring seen in Figure 1. These cables are now exposed to the environment and rodent chewing hazards. Materials can also react differently to other environmental stressors that come with heat or rain.

The variety of factors that can cause material degradation and lead to product failures show the importance of understanding how specific materials and products made from these materials will react in variable environmental conditions.

Multi-Stress Material Testing

To evaluate materials used in wire management products, Wiley has looked at standards across industries for testing that encompasses many of the environmental stressors seen by real-world installations.

One of the harsher test methods comes from the transmission insulator standard IEC 61109. This standard submits products to cycles of UV radiation, salt fog, rain, heat, and humidity with new cycles starting every 24 hours. The 24-hour cycle as defined in the standard is shown in Figure 2.

Samples of Wiley products and products made from alternate materials were chosen to be tested under the IEC multi-stress sequence to determine the optimal materials to be used for installation longevity. Multiple polymer and metal solutions were installed on a condensed structure made to support module frames at a 30° angle to mimic installation in the field.

Product designed to directly support wires then had wires installed as defined in product specific manuals and weights were added to simulate forces seen in full size installations. The structure with products installed and then hung in the environmental chamber meeting the minimum distance to the UV source can be seen in Figure 3.

While in the environmental chamber the materials were subjected to the wide variety of environmental stressors as described previously, and shown in Figure 2, for a total of 1500 hours. This was determined to be sufficient time to compare the reactions of materials tested due to the discoloration seen in the anodized aluminum module frames, degradation of pure aluminum support members and corrosion of low-grade stainless steel hardware.

Environmental Considerations in Wire Management

(Continued)

As the materials progressed through the testing sequence, parts were periodically inspected for signs of degradation. Material degradation could come in the form of corrosion, discoloration, or loss of function of the part as signified by an inability to hold the installed wires and weight.

Every 500 hours the materials were inspected, and images compiled for further evaluation. The progress of increasing degradation in one of the alternate material samples can be seen in Figure 4. It was found that corrosion occurs in this low-grade material at stress points where the material was formed through the manufacturing process. This shows the importance of testing complete parts to qualify a material as opposed to flat sheets of stock material.

Wiley grade material can be seen in Figure 5 which shows the resilience of higher-grade materials to the variable environmental stresses simulated through this testing.

Similar results were recorded in differing grades of polymer products. Cable ties made from nylon 6/6 were tested in addition to the more environmentally stable nylon 12 polymer blend. As can be expected, the nylon 12 samples held up to the variable stresses with greater resilience when compared to the nylon 6/6 products.

All materials were examined before and after the test period with a focus on reaction of materials to the simulated environmental stresses. Results were compared to results from pure salt spray testing and it was determined that the multi-stress testing is a valuable tool in determining and validating which materials will be suitable for use in outdoor environments with variable environmental conditions.

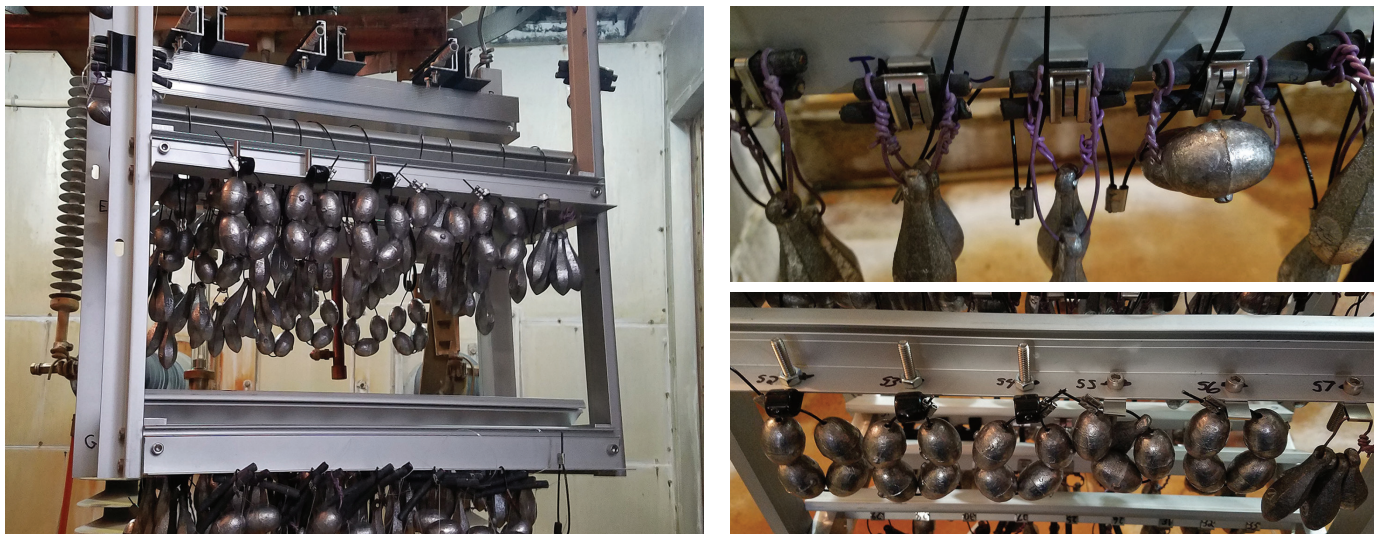

Figure 3 - Test fixture installed in environmental chamber



Figure 4 - Increasing material degradation at setup, 532 hrs, 1028 hrs, and 1540 hrs (left to right)

Environmental Considerations in Wire Management

(Continued)

Conclusions

As components vital to installation health and longevity, wire management products must be evaluated to determine if they will stand up to the test of time and survive in outdoor environments. Salt spray testing in accordance with ASTM B117 is a good baseline to determine which metal components are best resistant to alkaline corrosion.

While this is useful on a component to component level after materials have been selected, additional testing is needed to qualify and validate this material selection. Different materials react to different environmental stresses in unique ways, which is why testing that involves many of these stressors is vital.

The multi-stress sequence defined in IEC 61109 is one of the most stringent test methods and provides an outline for material evaluation and selection. Based on the results of testing, the high-grade materials used in Wiley products have been validated and will stand up to most harsh environments for the lifetime of an installation.

This PV-industry first testing once again proves the dedication of Wiley to customer safety, installation integrity, and a commitment to manufacturing products to a quality that customers have come to expect and appreciate from the Wiley brand name.



















Figure 5 - Wiley grade material pre- and post-test with no visible degradation

NEC®, National Electrical Code®, National Fire Protection Association®, and NFPA® are all registered trademarks of the National Fire Protection Association.

Quick Reference Guide

Part Description		Application	Type	UL Listing
	ACC	1 to 2 USE-2 cables or 1 PV cable Wire diameter range: 4.1mm - 5.5mm per each cable Flange thickness range: 1.3mm - 2.5mm	Module Frame or Flange Clip - Straight on	UL1565
	ACC-PV	1 to 2 USE-2 cables or 1 PV cable Wire diameter range: 4.1mm - 7.0mm per each cable Flange thickness range: 1.3mm - 2.5mm		
	ACC-FPV	1 to 2 PV cables Wire diameter range: 5.0mm - 8.0mm per each cable Flange thickness range: 1.3mm - 3.0mm		
	ACC-F90-1	1 to 2 PV cables Wire diameter range: 4.1mm - 7.1mm per each cable Flange thickness range: 1.3mm - 2.5mm	Module Frame or Flange Clip - both Straight on & 90 degree	
	ACC-F2-90	1 to 2 PV wires, Micro Inverter Trunk or AC cables Wire diameter range: 6.2mm - 8.0mm per each cable (2 cables) 6.2mm - 14.0mm per each cable (1 cable) Flange thickness range: 1.3mm - 2.5mm		
	ACC-F4-90	1 to 4 PV cables Wire diameter range: 4.1mm - 6.7mm per each cable Flange thickness range: 1.3mm - 2.5mm		
	ACC-FPV90	1 to 2 PV cables Wire diameter range: 5.0mm - 8.0mm per each cable Flange thickness range: 1.0mm - 3.0mm	Module Frame or Flange Clip - 90 degree	UL1565
	ACC-F490	1 to 4 PV cables Wire diameter range: 5.0mm - 8.0mm per each cable Flange thickness range: 1.0mm - 3.0mm		
	ACC-F4F	1 to 4 PV cables Wire diameter range: 5.0mm - 8.0mm per each cable Flange thickness range: 1.0mm - 3.0mm		
	ACC-FPV180	1 to 2 PV cables Wire diameter range: 5.0mm - 8.0mm per each cable Flange thickness range: 1.0mm - 3.0mm uncoated.	Module Frame or Flange Clip - both Straight on & 180 degree	
	ACC-F1-270	1 to 2 PV wires, Micro Inverter Trunk or AC cables Wire diameter range: Max 13.0mm in total Flange thickness range: 1.3mm - 2.5 mm	Module Frame or Flange Clip - both 180 & 90 degree	
	ACC-R2	1 to 2 PV wires, Micro Inverter Trunk or AC cables Wire diameter range: 4.1mm - 8.0mm per each cable (2 cables) 4.1mm - 14.0mm per each cable (1 cable) Racking: Unirac, Ironridge, or similar rack profiles	Top Rail Clip	
	ACC-R4	1 to 2 PV wires, Micro Inverter Trunk or AC cables Wire diameter range: 4.1mm - 6.5mm per each cable Racking: Unirac, Ironridge, or similar rack profiles		
	ACC-RBC15	Bundle of PV wire, Micro Inverter Trunk or AC cable Wire diameter range: Max 15mm in total Rail Channel or Slot Width: 6.35mm to 13.5mm	Rail Channel or Mounting Slot	

Quick Reference Guide

Part Description		Application	Type	UL Listing
	WIPC	For single cables or bundles - insulated p-clips easily install into a mounting hole with 1/4" hardware. Coating protects cables from vibration and insulation damage. UV resistant vinyl, zinc plated steel (304 SS available upon request). Available bundle diameters: 0.25" to 2"	P-Clip or Loom Clamp - installs into 1/4" mounting hole	UL1565
	ACC-FBC	Allows a cable tie to be routed in both landscape (on the horizontal portion of the module frame) and portrait (on the vertical portion of the module frame) orientations. Max cable tie width: 8mm Flange thickness range: 1.3mm - 3mm	Module Frame or Flange Clip - cable tie mounting base	
	WBS	For bundles of cable - easy to install and can be crimped in the field with electrician linesman pliers or standard wire cutters. 304 SS wire with UV rated vinyl jacketing. Available lengths: 8" to 36" Tensile strength: 100 lbs	Bundle Strap	UL62275
	WTS	For bundles or securement of cables. Stainless steel core with UV resistant PVC coating. Available lengths: 8" to 26" Tensile Strength: 40 lbs.	Bundling Strap	UL 1565 and 2239 Listed
	ACC-ECT	The ACC-ECT clip is a nylon-encased plated steel clip that installs onto module frames, flanges or purlins and allows a cable tie to be routed in a vertical/parallel (90°) or horizontal/perpendicular (180°) orientation. Available in various lengths and in UV resistant Nylon 6/6 or UV resistant Nylon 12	Edge Clip with Cable Tie	UL62275
	ACC-ECTW	The ACC-ECTW clip is a nylon-encased plated steel clip that installs onto flanges ranging from 3.0mm - 6.00mm and allows a cable tie to be routed in a vertical/parallel (90°) or horizontal/perpendicular (180°) orientation. Available in various lengths and in UV resistant Nylon 6/6 or UV resistant Nylon 12	Edge clip with Cable Tie	Pending UL62275
	WCH1 WCH2	For bundles of cable - easy to install. Models for use in any application using either module wire management or mounting holes or in varying locations at the torque tube level. 300 Series high tensile strength or galvanized steel with bundle diameters up to 2".	Module Mounting or Wire Management Hole Cable Hanger	UL1565
	WCH2B10		Tracker System (FTC/Game Change or Similar) Cable Hanger	
	WCH2H1090		Tracker System NexTracker Strap or similar) Cable Hanger	
	WCH2-90-15		Tracker system (NextTracker Strap or similar) Cable Hanger	
	WCH15ATI		Tracker System (ATI bracket or similar) Cable Hanger	
	WCHP2		Module Wire Management or Mounting Hole or for use with ACC-FBC Cable Hanger	
	WFHP115	For securing module connectors or over molded fuses. 300 Series high tensile strength or galvanized steel.	Module Wire Management or Mounting Hole or for use with ACC-FBC Fuse Holder Hanger	UL1565
	WFHP085			
	WCHJ-30HH	Specifically to support First Solar Series 7 module wires over NextTracker's bearing house assembly.	irst Solar Series 7 Module Wire Management Hol	
	Nylon 12 (CTNT)	For bundles of cable - UV resistant Nylon 12 Available lengths: 24" Tensile strength: 120 lbs	Cable Ties	-
	Stainless Steel (CTSS, CTSS-PC and CTSS-FC)	For bundles of cable - 304 Stainless. Polyester coated, partially coated, and uncoated. Available lengths: 8" to 42" Tensile strength: 225 lbs - 920 lbs		



Engineered for high-quality solutions, Wiley Wire Management products are constructed of the finest corrosion-resistant materials, ensuring top performance under the most extreme environmental conditions.

GET IN TOUCH:



Customer Service Department
1-800-346-4175
1-603-647-5299 (International)

Canada
1-800-465-7051

Mexico
011-52-722-265-4400

Tool Service Center
1-800-426-8720



www.hubbell.com/wiley



Littleton Industrial Park
Littleton, NH 03561

