



Hospital Grade Devices

Commercial Standard and Tamper-Resistant GFCI Receptacles



- Patented CIRCUITPRO® self test technology includes disconnecting power to the receptacle if critical components are damaged and GFCI protection is lost
- Tamper-Resistant version has Patented shutter design for extra protection
- Compliant with NEC® 406.12 and NEC® 517-18(c)
- Alarm version provides audible notification of a trip condition
- Internal back wiring clamp and guide for quick and secure termination
- Night light option includes light sensor controls for automatic ON and OFF, custom dual lens for optimum light output
- Fed. Spec. UL Listed (Hospital Grade)



Hospital Grade • Standard and Tamper-Resistant

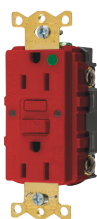

Rating	Color	Standard0	Night Light Two LED Night Lights		Alarm	
		Standard0	Tamper-Resistant	Standard0	Tamper-Resistant	
NEMA 5-15, 15A 125V 	Black	GFST82BK	GFST82BKNL	GFST82BKTRNL	GFST82BKB	GFST82BKTRB
	Brown	GFST82	GFST82NL	GFST82TRNL	GFST82B	GFST82TRB
	Gray	GFST82GY	GFST82GYNL	GFST82GYTRNL	GFST82GYB	GFST82GYTRB
	Ivory	GFST82I	GFST82INL	GFST82ITRNL	GFST82IB	GFST82ITRB
	Light Almond	GFST82LA	GFST82LANL	GFST82LATRNL	GFST82LAB	GFST82LATRB
	Red	GFST82R	GFST82RNL	GFST82RTRNL	GFST82RB	GFST82RTRB
	White	GFST82W	GFST82WNL	GFST82WTRNL	GFST82WB	GFST82WTRB
NEMA 5-20, 20A 125V 	Black	GFST83BK	GFST83BKNL	GFST83BKTRNL	GFST83BKB	GFST83BKTRB
	Brown	GFST83	GFST83NL	GFST83TRNL	GFST83B	GFST83TRB
	Gray	GFST83GY	GFST83GYNL	GFST83GYTRNL	GFST83GYB	GFST83GYTRB
	Ivory	GFST83I	GFST83INL	GFST83ITRNL	GFST83IB	GFST83ITRB
	Light Almond	GFST83LA	GFST83LANL	GFST83LATRNL	GFST83LAB	GFST83LATRB
	Red	GFST83R	GFST83RNL	GFST83RTRNL	GFST83RB	GFST83RTRB
	White	GFST83W	GFST83WNL	GFST83WTRNL	GFST83WB	GFST83WTRB

Product Dimensions Inches (mm)

GFCI Receptacle	
A	3.27" (83.1)
B	2.75" (69.8)
C	1.75" (44.5)
D	1.47" (37.4)
E	1.10" (27.9)

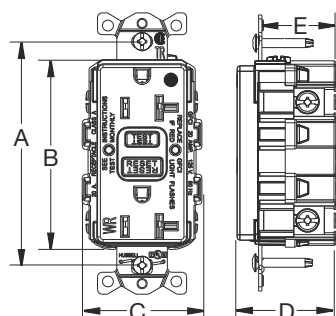

NEC® is a registered trademark of the National Fire Protection Association (NFPA).