

Commercial Tamper-Resistant and Weather Resistant GFCI Receptacles



- Patented shutter design for tamper-resistant protection
- Tamper-Resistant/Weather Resistant Series meets NEC® requirements for TR (517-18c) and WR (406.9), UV and corrosion resistance for harsh and damp applications
- Weather Resistant Only Series meets NEC® requirements for weather resistance (406.9), UV and corrosion resistance for harsh and damp applications
- Patented CIRCUITPRO® self test technology
- Protects against line and load reversal, no power to the face or downstream if device is miswired



Hospital Grade • Tamper-Resistant and Weather Resistant



Rating	Color	Standard	Isolated Ground
NEMA 5-15, 15A 125V 	Black	GFST82BKTR	GFST82BKIG
	Brown	GFST82TR	GFST82IG
	Gray	GFST82GYTR	GFST82GYIG
	Ivory	GFST82ITR	GFST82IIG
	Light Almond	GFST82LATR	GFST82LAIG
	Orange	—	GFST82ORIG
	Red	GFST82RTR	GFST82RIG
	White	GFST82WTR	GFST82WIG
NEMA 5-20, 20A 125V 	Black	GFST83BKTR	GFST83BKIG
	Brown	GFST83TR	GFST83IG
	Gray	GFST83GYTR	GFST83GYIG
	Ivory	GFST83ITR	GFST83IIG
	Light Almond	GFST83LATR	GFST83LAIG
	Orange	—	GFST83ORIG
	Red	GFST83RTR	GFST83RIG
	White	GFST83WTR	GFST83WIG

Product Dimensions Inches (mm)

GFCI Receptacle	
A	3.27" (83.1)
B	2.75" (69.8)
C	1.75" (44.5)
D	1.47" (37.4)
E	1.10" (27.9)

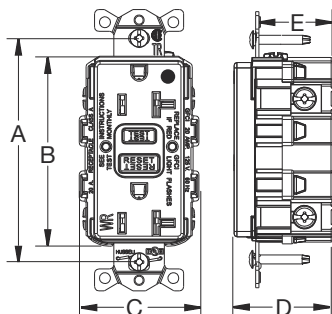

NEC® is a registered trademark of the National Fire Protection Association (NFPA).