



Commercial Tamper-Resistant GFCI Receptacles



Features

- Patented CIRCUITPRO® self-test technology includes disconnecting power to the receptacle if critical components are damaged and GFCI protection is lost
- Patented shutter design for tamper-resistant protection
- Compliant with NEC® 406.12 and NEC® 517-18(c)
- Alarm version provides audible notification of a trip condition



Tamper-Resistant

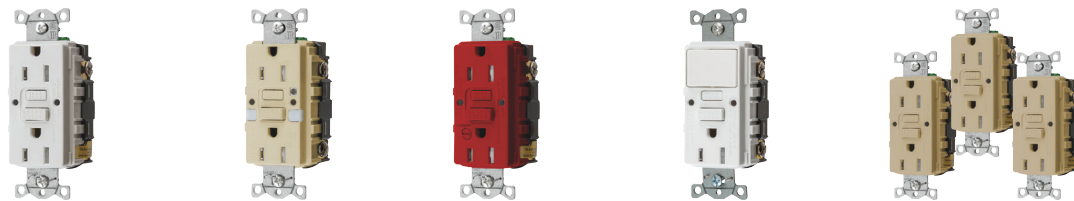

Rating	Color	Standard	Night Light Two LED Night Lights	Alarm	Combination Switch 15A 120V Switch	Standard 3-Pack Three Devices per Pack
NEMA 5-15, 15A 125V 	Black	GFTRST15BK	GFTRST15BKNL	GFTRST15BKB	—	—
	Brown	GFTRST15	GFTRST15NL	GFTRST15B	—	—
	Gray	GFTRST15GY	GFTRST15GYNL	GFTRST15GYB	—	—
	Ivory	GFTRST15I	GFTRST15INL	GFTRST15IB	GFSPST15I	GFTRST15I3
	Light Almond	GFTRST15LA	GFTRST15LANL	GFTRST15LAB	GFSPST15LA	GFTRST15LA3
	Red	GFTRST15R	GFTRST15RNL	GFTRST15RB	—	—
	White	GFTRST15W	GFTRST15WNL	GFTRST15WB	GFSPST15W	GFTRST15W3
NEMA 5-20, 20A 125V 	Black	GFTRST20BK	GFTRST20BKNL	GFTRST20BKB	—	—
	Brown	GFTRST20	GFTRST20NL	GFTRST20B	—	—
	Gray	GFTRST20GY	GFTRST20GYNL	GFTRST20GYB	—	—
	Ivory	GFTRST20I	GFTRST20INL	GFTRST20IB	—	GFTRST20I3
	Light Almond	GFTRST20LA	GFTRST20LANL	GFTRST20LAB	—	GFTRST20LA3
	Red	GFTRST20R	GFTRST20RNL	GFTRST20RB	—	—
	White	GFTRST20W	GFTRST20WNL	GFTRST20WB	—	GFTRST20W3



Hospital Grade Tamper-Resistant

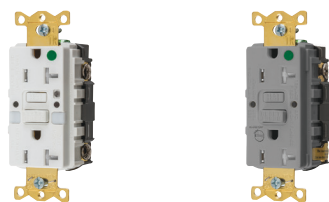

Rating	Color	Night Light Two LED Night Lights	Alarm
NEMA 5-15, 15A 125V 	Black	GFST82BKTRNL	GFST82BKTRB
	Brown	GFST82TRNL	GFST82TRB
	Gray	GFST82GYTRNL	GFST82GYTRB
	Ivory	GFST82ITRNL	GFST82ITRB
	Light Almond	GFST82LATRNL	GFST82LATRB
	Red	GFST82RTRNL	GFST82RTRB
	White	GFST82WTRNL	GFST82WTRB
NEMA 5-20, 20A 125V 	Black	GFST83BKTRNL	GFST83BKTRB
	Brown	GFST83TRNL	GFST83TRB
	Gray	GFST83GYTRNL	GFST83GYTRB
	Ivory	GFST83ITRNL	GFST83ITRB
	Light Almond	GFST83LATRNL	GFST83LATRB
	Red	GFST83RTRNL	GFST83RTRB
	White	GFST83WTRNL	GFST83WTRB

Product Dimensions Inches (mm)

	GFCI Receptacle
A	3.27" (83.1)
B	2.75" (69.8)
C	1.75" (44.5)
D	1.47" (37.4)
E	1.10" (27.9)

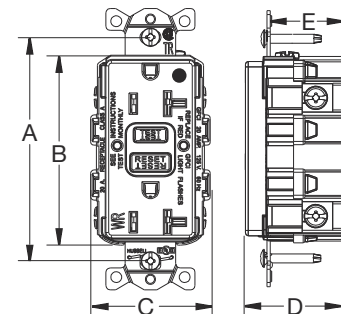

NEC® is a registered trademark of the National Fire Protection Association (NFPA).