

# Wallplates and Covers

## Weatherproof Covers

### 1-Gang Non-Metallic Covers, Vertical Mount for Flanged Devices

Description	Catalog Number
Weatherproof lift cover for use with 15 amp locking flanged equipment devices (inlets and receptacles)	<b>WPC1</b>
Weatherproof lift cover for use with 20 and 30 amp locking flanged equipment devices (inlets and receptacles)	<b>WPC2</b>
Weatherproof lift cover for use with 50 amp locking non-metallic flanged inlets	<b>7780*</b>



Note: \*cULus Listed only, not CSA Certified.

### Use with Flanged Inlets and Flanged Receptacles Listed Below

Catalog Number	Use with flanged inlets and flanged receptacles listed below							
<b>WPC1</b>	<b>4716MB</b>	<b>4715ER</b>	<b>70615MB</b>	<b>70615ER</b>	<b>4786MB</b>	<b>4785ER</b>	<b>7556MB</b>	<b>7557ER</b>
	<b>8808</b>	<b>8809</b>						
<b>WPC2</b>	<b>70520MB</b>	<b>70520ER</b>	<b>70620MB</b>	<b>70620ER</b>	<b>70720MB</b>	<b>70720ER</b>	<b>70820MB</b>	<b>70820ER</b>
	<b>70920MB</b>	<b>70920ER</b>	<b>70530MB</b>	<b>70530ER</b>	<b>70630MB</b>	<b>70630ER</b>	<b>70730MB</b>	<b>70730ER</b>
	<b>70830MB</b>	<b>70830ER</b>	<b>70930MB</b>	<b>70930ER</b>	<b>7327</b>	<b>7328</b>	<b>71020MB</b>	<b>71020ER</b>
	<b>71120MB</b>	<b>71120ER</b>	<b>71220MB</b>	<b>71220ER</b>	<b>71030MB</b>	<b>71030ER</b>	<b>71230MB</b>	<b>71230ER</b>
	<b>71330MB</b>	<b>71330ER</b>	<b>71420MB</b>	<b>71420ER</b>	<b>71520MB</b>	<b>71520ER</b>	<b>71620MB</b>	<b>71620ER</b>
	<b>71430MB</b>	<b>71430ER</b>	<b>71530MB</b>	<b>71530ER</b>	<b>71630MB</b>	<b>71630ER</b>	<b>71730MB</b>	<b>71730ER</b>
	<b>7408MB</b>	<b>7409ER</b>	<b>71820MB</b>	<b>71820ER</b>	<b>71920MB</b>	<b>71920ER</b>	<b>72020MB</b>	<b>72020ER</b>
	<b>71830MB</b>	<b>71830ER</b>	<b>71930MB</b>	<b>71930ER</b>	<b>72030MB</b>	<b>72030ER</b>	<b>72120MB</b>	<b>72120ER</b>
	<b>72220MB</b>	<b>72220ER</b>	<b>72320MB</b>	<b>72320ER</b>	<b>40045MB</b>	<b>40045ER</b>	<b>72130MB</b>	<b>72130ER</b>
	<b>72230MB</b>	<b>72230ER</b>	<b>72330MB</b>	<b>72330ER</b>				
<b>7780</b>	<b>CS6375L</b>							
	<b>CS8375L</b>							



Note: Device not included.

### Product Dimensions Inches (mm)

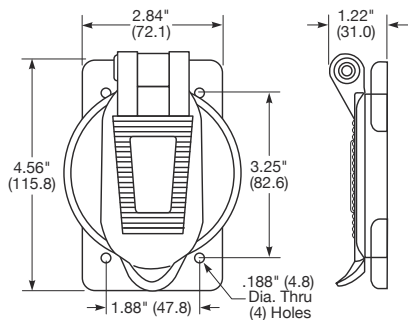

**WPC2**

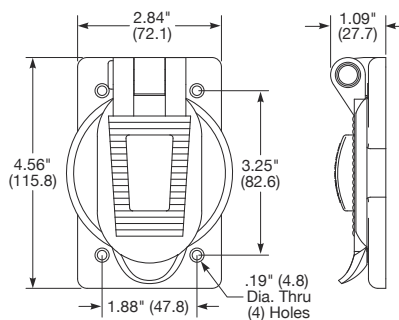

**7780**