

CPI™ Shear Bolt WEJTAP™ Connectors with Captive Interface

#4 - 350 Small Series Aluminum Tap

CPI Aluminum Taps are designed for use as a permanent connection for aluminum and copper conductors. CPI wedge connectors use high strength aluminum alloy, pure aluminum and a unique shear head bolt for a mechanically strong, electrically conductive and easy to install connection. The new Captive Interface is now "held" by the connector to facilitate installation and eliminate the risk of the interface falling. The Captive Interface also allows for conductor side entry which simplifies the installation.

Features and Benefits

- The new Captive Interface is contained by the C Body so it cannot fall out during installation
- The new Captive Interface allows conductor side entry which simplifies installation
- Industry-proven spring wedge technology easily installed with common socket or impact wrench - No Special Tools Required!
- "Spring Like" high strength C-Body ensures permanent connection with consistent pressure on the conductors
- Meets or exceeds current carrying capacity of conductors being connected
- Corrosion resistant highly conductive aluminum alloys with a pure aluminum insert between conductors increases conductivity and lowers electrical resistance
- Corrosion inhibitor factory applied for ease of installation
- Remains permanently locked through fault current or power surges
- Easy to remove without damage to conductor
- May be used in non-corrosive environments to connect copper conductors
- Excellent option for emergency restoration where outside crews might not have Shoot-On or compression tooling

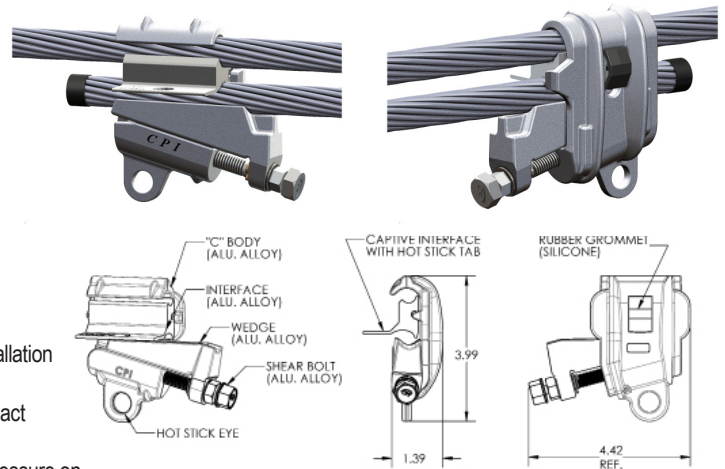

Catalog Number	Conductor			
	Main	Main Dia. Range	Tap	Tap Dia. Range
640101F	#6	0.162"-0.232"	#6, #4 SOLID	0.162"-0.204"
240100F	#4, #2, #1 AAC	0.232"-0.328"	#6, #4 SOLID	0.162"-0.204"
240101F			#4	0.232"-0.257"
240102F			#2, #1 AAC	0.292"-0.328"
210103F	#1 ACSR, 1/0, 2/0 AAC	0.354"-0.414"	#6 ACSR, #4 AAC	0.198"-0.232"
210105F			#4, #2, #1 AAC	0.232"-0.328"
210106F			#1 ACSR, 1/0, 2/0 AAC	0.354"-0.414"
230107F	2/0 ACSR, 3/0	0.447"-0.502"	#6 ACSR, #4 AAC	0.198"-0.232"
230108F			#4, #2, #1	0.232"-0.354"
230110F			#1 ACSR, 1/0, 2/0 AAC	0.354"-0.414"
230111F			2/0 ACSR, 3/0	0.447"-0.502"
264111F	3/0 ACSR, 4/0 250 AAC	0.502"-0.574"	#6 ACSR, #4, #1 AAC	0.198"-0.328"
264113F			#1 ACSR, 1/0, 2/0 AAC	0.316"-0.414"
264114F			2/0 ACSR, 3/0	0.447"-0.502"
264115F			4/0, 250 AAC	0.522"-0.574"
350117F	266.8 ACSR, 300 MCM, 336.4 AAC 336.4 ACSR 18/1, 350 MCM	0.609"-0.684"	#6, #4 AAC	0.162"-0.232"
350118F			#4	0.232"-0.257"
350119F			#2, #1 AAC	0.292"-0.328"
350120F			#1, 1/0 AAC	0.328"-0.368"
350121F			1/0 ACSR, 2/0	0.398"-0.447"
350122F			2/0 ACSR, 3/0	0.447"-0.502"
350123F			4/0, 250	0.522"-0.574"
350124F			266.8-19 AAC, 300 AAC, 266.8 ACSR	0.592"-0.642"
350125F			300 ACSR	0.665"-0.684"

Not recommended for copper to copper applications, use copper Bolted WEJTAP™. Use a 9/16 socket to install and remove the bolt.

CPI™ Shear Bolt WEJTAP™ Connectors with Captive Interface

336.4 - 636 Medium Series Aluminum Tap

CPI Aluminum Taps are designed for use as a permanent connection for aluminum and copper conductors. CPI wedge connectors use high strength aluminum alloy, pure aluminum and a unique shear head bolt for a mechanically strong, electrically conductive and easy to install connection. The new Captive Interface is now “held” by the connector to facilitate installation and eliminate the risk of the interface falling. The Captive Interface also allows for conductor side entry which simplifies the installation.

Features and Benefits

- The new Captive Interface is contained by the C Body so it cannot fall out during installation
- The new Captive Interface allows conductor side entry which simplifies installation
- Industry-proven spring wedge technology easily installed with common socket or impact wrench - No Special Tools Required!
- “Spring Like” high strength C-Body ensures permanent connection with consistent pressure on the conductors
- Meets or exceeds current carrying capacity of conductors being connected
- Corrosion resistant highly conductive aluminum alloys with a pure aluminum insert between conductors increases conductivity and lowers electrical resistance
- Corrosion inhibitor factory applied for ease of installation
- Remains permanently locked through fault current or power surges
- Easy to remove without damage to conductor
- May be used in non-corrosive environments to connect copper conductors
- Excellent option for emergency restoration where outside crews might not have Shoot-On or compression tooling

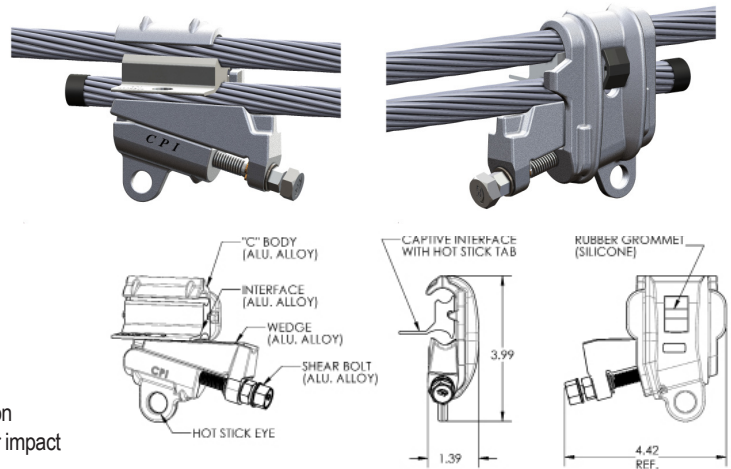

Catalog Number	Conductor			
	Main	Main Dia. Range	Tap	Tap Dia. Range
336222F	300 MCM, 336.4, 350 MCM, 397 ACSR 18/1	0.63"-0.743"	#6, #4, #3 Cu	0.162"-0.292"
336104F	336.4, 350	0.666"-0.743"	#4 ACSR, #2, 1/0 AAC	0.257"-0.368"
336012F	MCM,		1/0, 2/0, 3/0	0.368"-0.502"
336866F	397 ACSR		4/0 ACSR, 266.8 AAC	0.522"-0.592"
336718F	18/1		266.8 ACSR 36/7, 336.4, 397.5	0.642"-0.806"
477057F	397 ACSR, 24/7, 450 MCM, 477, 500 MCM, 556.5 AAC	0.769"-0.858"	#6 AAC, #4, #2	0.162"-0.316"
477962F			#2, 1/0	0.292"-0.398"
477853F			1/0 ACSR, 2/0, 3/0 AAC	0.398"-0.464"
477724F			3/0 ACSR, 4/0, 250, 266.8, 300 AAC	0.502"-0.628"
477633F			266.8 ACSR 36/7, 300 AAC, 336.4 397.5 ACSR 24/7	0.628"-0.772"
477434F			336.4 ACSR 26/7, 397, 477, 500 MCM, 556 AAC	0.72"-0.858"
556956F			477 ACSR	#6, #4, #2
556892F	26/7, 556,	#2, #1, 1/0	0.292"-0.398"	
556783F	600 MCM,	1/0, 2/0, 3/0, 4/0 AAC	0.368"-0.52"	
556638F	636 ACSR	4/0, 250, 266.8, 300 MCM, 336 AAC, 350 MCM	0.522"-0.68"	
556504F	18/1,	350 MCM, 336.4, 397.5, 477 AAC	0.68"-0.806"	
556294F	605 ACSR	397 ACSR 30/7, 477, 500 MCM, 556.5, 636 AAC	0.795"-0.918"	

Not recommended for copper to copper applications, use copper Bolted WEJTAP™. Use a 3/4 socket to install and a 9/16 socket to remove the bolt.