

LINE TERMINALS - WIRE CAPACITY AND QUANTITY (60/75 °C CU) 1

MAXIMUM MOTOR HORSEPOWER		WIRE SIZE PER PHASE		TIGHTENING TORQUE (in-lb)			
200-	440-550-	100-200K AIC		wire size	torque	wire size	torque
208	240	415	600	#12-#10	35	#8-#3	100
40	50	75	100	(1)#12AWG-#3/OAWG		#8-#4	150
75	75	150	150	(1)#8AWG-350 kcmil	150	#8-#1	200
200	200	350	400	(2)#2/OAWG-400 kcmil*		#8-#3	275
				or (1)#6AWG-600 kcmil			375

MOTOR TERMINALS-WIRE CAPACITY AND QUANTITY (60/75 °C CU) 1

MAXIMUM MOTOR HORSEPOWER		WIRE SIZE PER PHASE		TIGHTENING TORQUE (in-lb)	
200-	220-380-	440-	550-	200-	300
208	240	415	600	(1)#10AWG-#1/OAWG	150
25	30	50	75	(1)#8AWG-#3/OAWG *	200
60	60	125	150	(1)#1/OAWG-500 kcmil*	300
75	100	150	200	(2)#2/OAWG-500 kcmil*	375

1 For correct field wire sizing, refer to the National Electrical Code, NFPA-70.
* Denotes 75 °C wire only.

2 When required by the authority having jurisdiction.

NOTES

- Incoming line terminals are provided to accommodate wire sizes at 125% of motor full load current per NFPA 70, Article 6-3.4, and NFPA 70 Tables 430-150 and 310-16. Copper (CU) wire is recommended.
- Controller is phase rotation sensitive. Incoming lines L1, L2 and L3 must be in ABC, right hand rotation sequence for proper operation of the phase monitor.
- Motor connections shown are typical. Since motor connections vary widely, refer to the motor manufacturer's connection diagram for specific wiring arrangement.

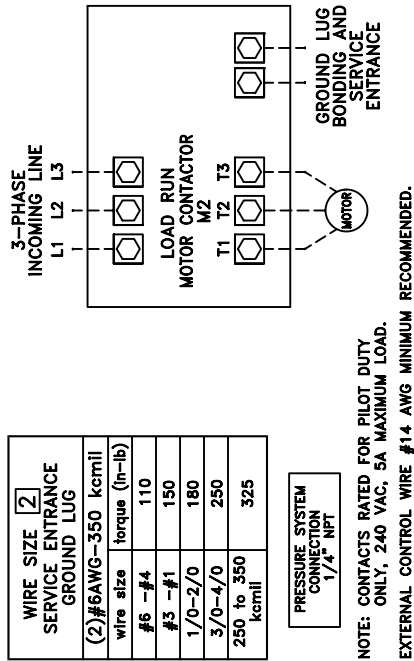

CONTROL AND ALARM TERMINAL BLOCKS

- CONTACTS SHOWN IN NO POWER CONDITION, PUMP OFF.
- FOR FIRE PUMP CONTROLLER SCHEMATIC DIAGRAM, SEE DWG. 14CS0011.

STANDARD LXI-1400 FIELD CONNECTIONS
PRIMARY START
FULL SERVICE FIRE PUMP CONTROLLER

M/L NO.
MOTION:
REF.
CADD NO. 14CF0011
DATE 08/02/02 DR. TR
CK. DAMA APPR.

Hubbell Industrial Controls, Inc.
4301 Cheyenne Drive, Archdale, N.C. 27283
DRG. NO. A-14CF0011
1 OF 1

Rev.	DATE	BY	DESCRIPTION
E			
D			
C	11/10/05	DAMA	UPDATED DWG. PER ECR #A05-00035.
B	09/21/04	TR	UPDATED TB2 CONNECTIONS.
A	10/26/02	DAMA	ADDED TB2 AND J105 CONNECTIONS.