

Installation Instructions for Underpinning Brackets C150-0121 and C150-0299

These products must be installed by Chance certified dealers trained to install the CHANCE® Helical Pile System.

1. Bracket C1500121 is used with 1½ inch (38 mm) SS5 & SS150 Square Shaft and 2⅞ inch (73 mm) RS2875.203 & RS2875.276 Round Shaft helical piles.

Bracket C1500299 is used with 1¾ inch (44 mm) SS175 Square Shaft helical piles.

Always use the correct bracket and T-Pipe for the helical pile installed. Brackets are stamped on the vertical gussets, either 1½ & 2⅞ or 1¾, for proper identification (see diagram below).

Bracket Body, Lifting Bolts and Crossbolt

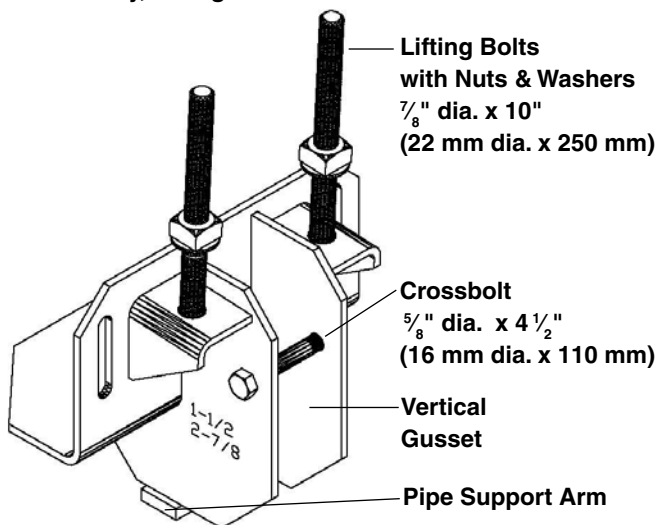

2. Excavate a hole at each location where an underpinning bracket is to be installed. The hole should not be over-excavated so that soil disturbance is minimized. Generally a hole 12 inches (300 mm) below the footing is required to install the bracket. The width of the hole should be at least 18 inches (450 mm).

⚠ WARNING

Potential for Soil Collapse.

Can cause personal injury or death.

When digging large holes, take appropriate shoring measures. Always abide by all local and OSHA requirements.

3. Clean off soil attached to the bottom of footing. Prepare the footing by chipping away irregularities from the bottom and sides. Typically, the footing is chipped to be flush with the wall, minimizing eccentricity. The bracket must fit snugly and be flush to the foundation (see diagram below).

⚠ WARNING

Incorrect footing preparation will prevent proper seating of the bracket against the footing. Can result in bracket rotation, or damage to the bracket, pile, jacking equipment, footing or entire structure.

Provide flat, smooth surface for the bracket to mount against.

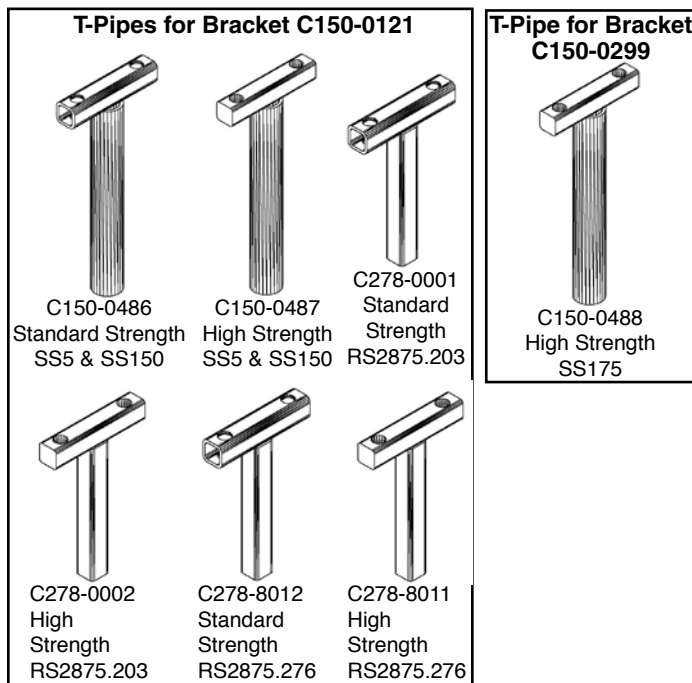

CORRECT Installation

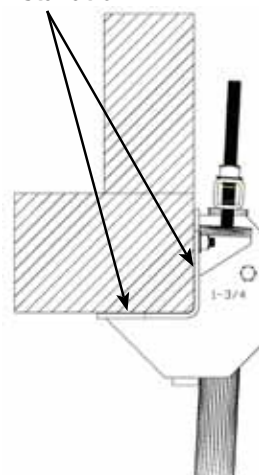

UNACCEPTABLE Installation

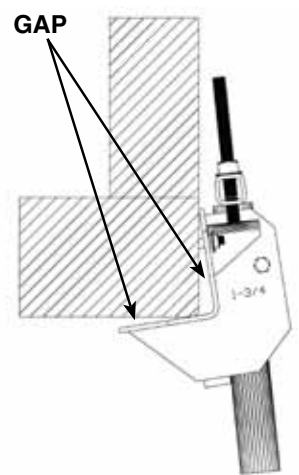

4. Place the helical pile in the excavated hole. The pile should be centered along the width of the hole. Secure the top of the helical pile to the installing tool/hydraulic torque motor. Always use the bent arm pin and coil lock provided for secure attachment of the helical pile to the installing equipment.

continued on next page . . .

- For single helix piles, the helix should be placed under the foundation with the pile shaft at a 3 to 5 degree angle from vertical and the shaft should be as close to the foundation as possible.

⚠ WARNING

Misuse of helical pile installing equipment can result in property damage, severe injury, or death. Read and understand the instructions and warnings included with the installing equipment before beginning helical pile installation.

⚠ WARNING

Helical piles are electrically conductive.

Avoid contact with underground utilities. Contact between helical pile and underground objects may result in serious injury, death and/or property damage.

Before installing the helical pile, determine the location of all underground utilities (electric, gas, water, sewer, telephone, CATV, etc.) to prevent accidental helical pile contact or puncture.

For two and three helix piles, the Lead Section should be started farther from the foundation than a single helix pile. In addition, the pile shaft should initially be at a greater angle (up to 10 degrees from vertical). When the upper most helix has been installed below the foundation, the pile must be forced over against the foundation. An extension may be added for additional leverage, but the Lead Section must be forced against the foundation. At this point, the Lead Section shaft with helices must be at a 3 to 5 degree angle from vertical with the shaft as close to the foundation as possible. If this is not achieved, you must remove the pile and restart the process.

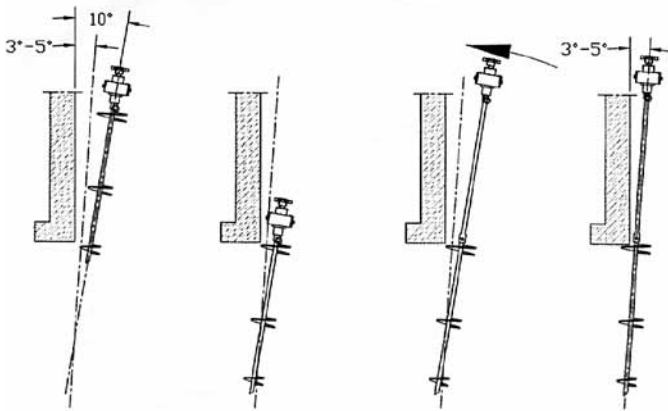

NOTE: It may be difficult or impossible to correctly install (shaft at 3 to 5 degrees from vertical with the shaft as close to the foundation as possible) multi-helix piles with portable installation equipment. It is recommended to use power equipment such as a mini excavator to install multi-helix piles.

- With the helical pile at 3 to 5 degrees, begin the installation by applying both down pressure and rotational torque to the pile. Once the pile has begun penetrating the soil, down pressure should no longer be required. Continue to drive the helical pile at 3 to 5 degrees from vertical. Add extension shafts as necessary until the predetermined torque has been obtained. This predetermined torque should be maintained for at least the final three feet (1 m) of penetration before stopping the installation.

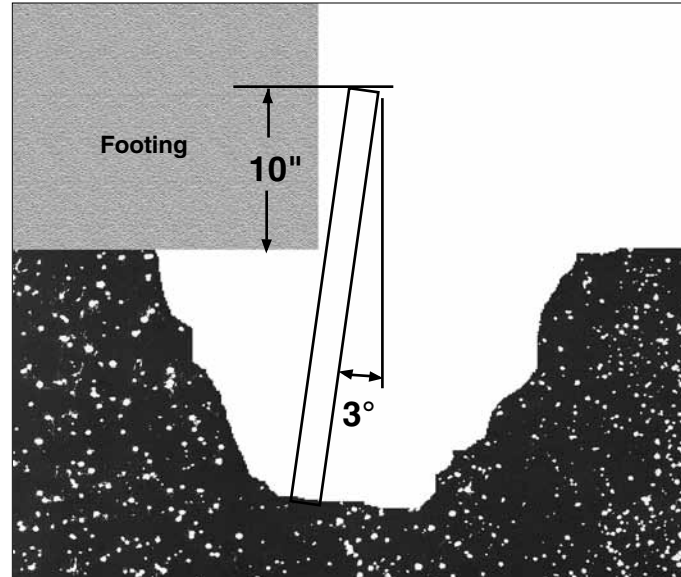

- The helical pile shaft should be terminated or cut off 10 inches (254 mm) above the bottom of the cleaned and prepared footing. A portable band saw may be used to cut the shaft at the required elevation.
- Remove the crossbolt from between the two vertical gussets of the bracket. There are two methods to install the bracket that connects the helical pile to the foundation.

The first method is to slide the fully assembled bracket (with the crossbolt removed) and T-Pipe over the helical pile shaft backwards (bracket facing away from foundation). If using a RS2875.203 Round Shaft, the T-Pipe slides inside the 2⁷/₈ (73 mm) pipe shaft. Then, rotate the bracket 180 degrees until it is facing the footing. Lift the bracket up until it is in the correct position (flush with foundation). Reinstall the crossbolt and tighten the lifting bolts so that the bracket remains flush with the foundation.

The second method will be easier if work space is limited due to the excavated hole size or accessibility. Slide the fully disassembled bracket sub-assembly down the helical pile shaft and into position similar to the first method. Now slide the T-Pipe over the Square Shaft helical pile or inside the 2⁷/₈ (73 mm) Round Shaft. Lift the bracket using the lifting bolts and crossbolt, again making sure the bracket is seated flush with the foundation.

9. Check to see that the T-Pipe is all the way down on the helical pile shaft; gently tapping the top of the T-Pipe with a hammer may be required. The pipe support arm located on the bottom of the bracket body must be seated snugly against the T-Pipe.
10. Drill two holes into the foundation using the mounting bolt slots of the bracket as a drill guide. Follow the directions of the anchor bolt manufacturer when installing the anchor bolts. The underpinning bracket requires two $\frac{5}{8}$ -inch (16 mm) anchor bolts, each with 10,700 lb. (2,400 kN) of ultimate tension capacity.
11. Attach the appropriate jacking tool to the top of the lifting bolts. The lifting bolts are installed from the bottom, up through the bracket, through the T-Pipe, washer and square nut. There must be at least one inch of lifting bolt thread above the square nut for adequate thread engagement with the jacking tool.

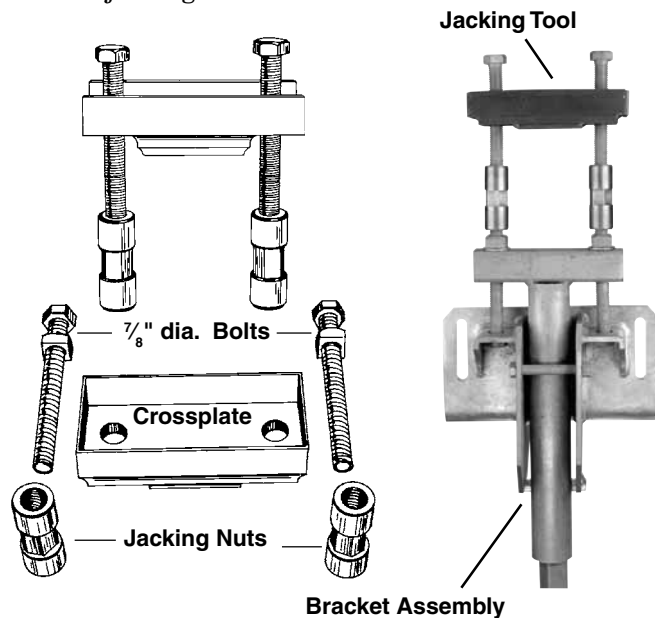

12. Place the jack or hydraulic cylinder between the T-Pipe and the cross-plate on the jacking tool. Adjust the height of the jacking tool as required to meet the height of the jack.

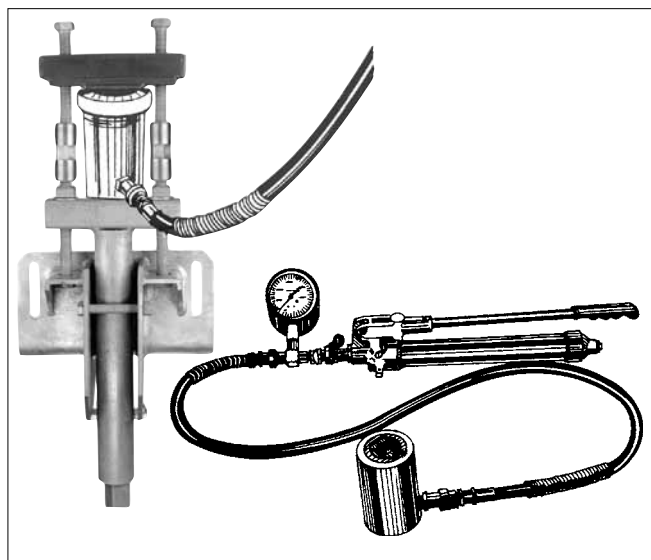

13. Apply a small amount of pressure to the jack, just enough to take up the "slack" in the assembly. Once again, check to see if the bracket is still mounted flush with the foundation. Tighten the cross-bolt if necessary and check the bracket mounting bolts again before proceeding.

⚠ WARNING

Potential for structural collapse.

Can cause property damage, personal injury or death.

Do not raise the foundation unless the necessary structural considerations have been made. Structural integrity of the foundation must be determined by qualified personnel before lifting or stabilizing. A plan of repair must be made and followed to prevent overloading of the foundation, helical pile or bracket.

⚠ WARNING

Potential crushing hazard.

Can cause personal injury or death.

Stay clear of any voids created under the foundation during lifting.

14. More pressure can now be applied to the jack to lift or stabilize the structure. Always use a jack with a pressure gauge in order to monitor the lifting force. A manifold system can allow control of the hydraulic pressure on multiple jacks/cylinders simultaneously and greatly assist during a lifting procedure.

The square nuts on the lifting bolts that tighten against the T-Pipe cross-bar should be tightened frequently during the jacking process. This transfers load to the bracket body. Set up reference points on the foundation to monitor movement both inside and outside the structure.

15. Once lifting or stabilizing the structure is complete, tighten the square nuts on the lifting bolts against the T-Pipe cross-bar.
16. When the nuts on the lifting bolts are tight, release the pressure from the jack. Remove the jack and jacking tool before backfilling the hole.

For Bracket and T-Pipe Ratings, see next page . . .

CHANCE® Helical C150-0121 Standard Bracket and T-Pipe Ratings

T-Pipe Catalog Numbers for the C150-0121 Bracket	Ultimate Mechanical Strength ^{1,3} lbs (kN)	Pile Size in (mm)	Product Series	Max Working Capacity ^{2,3} based on Product Series lbs (kN)
C150-0486 ⁴	40,000 (178)	1½ (38) Square	SS5 SS150	20,000 (89) 20,000 (89)
C150-0487 ⁴	80,000 (356)	1½ (38) Square	SS5 SS150	20,000 (89) 25,000 (111)
C278-0001	40,000 (178)	2⅞ (73) Round	RS2875.203	20,000 (89)
C278-0002	80,000 (356)	2⅞ (73) Round	RS2875.203	25,000 (111)
C278-8012	40,000 (178)	2⅞ (73) Round	RS2875.276	20,000 (89)
C278-8011	80,000 (356)	2⅞ (73) Round	RS2875.276	30,000 (133)

CHANCE® Helical C150-0299 Standard Bracket and T-Pipe Ratings

T-Pipe Catalog Numbers for the C150-0299 Bracket	Ultimate Mechanical Strength ^{1,3} lbs (kN)	Pile Size in (mm)	Product Series	Max Working Capacity ^{2,3} based on Product Series lbs (kN)
C150-0488 ⁴	80,000 (356)	1¾ (44) Square	SS175	30,000 (133)

Notes:

1. Ultimate mechanical strength is for the Bracket Body and T-Pipe combination.
2. The capacity of CHANCE® Helical Pile Systems is a function of many individual elements, including the capacity of the foundation, bracket, pile shaft, helix plate and bearing stratum, as well as the strength of the foundation-to-bracket connection, and the quality of the helical pile installation. The fifth column shows typical working capacities of the CHANCE® Helical Pile System based upon maximum shaft exposure of 2 feet and soil strength having a minimum Standard Penetration Test (SPT) Blow Count "N" of 4. Actual capacities could be higher or lower depending on the above factors.
3. The ultimate capacity of the system, i.e., bracket, T-pipe, and pile shaft, can be increased to the pile shaft compression capacity limit as shown in the CHANCE® Technical Design Manual provided the pile shaft is reinforced using a pipe sleeve or grout column. The maximum working capacity shall not be greater than one half the ultimate mechanical strength of the bracket and T-pipe combination given above.
4. These products comply with the 1997 Uniform Building Code, the 1999 BOCA National Code, and the 1999 SBCCI Standard Code subject to the conditions as listed in the ICC-ES Legacy Reports.



NOTE: Because Hubbell has a policy of continuous product improvement, we reserve the right to change design and specifications without notice.

Chance/Hubbell
210 N. Allen, Centralia, MO 65240

Printed in USA



©Copyright 1999 - 2010 Hubbell Incorporated