



Title

# 4 CHANNEL ANALOGUE RECEIVER TYPE SILBUS-RX4A USER MANUAL

Document Number

## 120-208-12

Issue

## 04





## REVISION CONTROL

|       |                               |            |         |          |          |
|-------|-------------------------------|------------|---------|----------|----------|
| 04    | Amend section 6.1 and table 3 | 2017.11.23 | PC      | PC       | JY       |
| 03    | Address and Logo Update       | 2017.04.07 | CW      | CW       | PC       |
| 02    | Fix specs, add prog info      | 2010.02.02 | PB'     | PB'      | JY       |
| 01    | Original                      | 2009.02.10 | PB'     | PB'      | JY       |
| Issue | Details                       | Date       | Written | Designed | Approved |

**Austdac Pty Ltd**  
Unit 1 / 42 Carrington Road  
Castle Hill NSW 2154  
Australia

PO Box 6486  
Baulkham Hills Business Centre  
NSW 2153  
Australia

Phone: + 61 2 8851 5000  
Fax: + 61 2 8851 5001  
Website: [www.austdac.com.au](http://www.austdac.com.au)

455 Lowries Run Rd,  
Pittsburgh, PA 15237  
USA

Phone: +1 888 254 9155  
Fax: +1 412 635 0179

Copyright 2017

This document remains the property of Austdac Pty. Ltd. It is subject to its recall and must not be reproduced in part or whole or its contents divulged to third parties without prior written approval from Austdac Pty Ltd.

## TABLE OF CONTENTS

|                                           |    |
|-------------------------------------------|----|
| REVISION CONTROL .....                    | 2  |
| TABLE OF CONTENTS .....                   | 3  |
| PHOTOGRAPHS .....                         | 4  |
| TABLES .....                              | 4  |
| FIGURES .....                             | 4  |
| 1 GENERAL DESCRIPTION .....               | 5  |
| 2 FRONT PANEL LAYOUT .....                | 5  |
| 3 THEORY OF OPERATION .....               | 6  |
| 4 OPERATING INSTRUCTIONS .....            | 8  |
| 5 CONFIGURATION .....                     | 9  |
| 5.1 CONSOLE PORT OPERATION .....          | 9  |
| 5.2 HELP COMMAND .....                    | 10 |
| 5.3 REPEAT COMMAND .....                  | 10 |
| 5.4 VERSION COMMAND .....                 | 11 |
| 5.5 STACK COMMAND .....                   | 12 |
| 5.6 SILBUS MAP COMMAND .....              | 12 |
| 5.7 SILBUS STATUS COMMAND .....           | 12 |
| 5.8 SILBUS GET COMMAND .....              | 13 |
| 5.9 ANALOGUE OUTPUT ADDRESS COMMAND ..... | 13 |
| 5.10 FAULT ADDRESS COMMAND .....          | 14 |
| 5.11 FAULT LEVEL COMMAND .....            | 15 |
| 5.12 fault hysteresis command .....       | 15 |
| 5.13 analogue SELECT command .....        | 16 |
| 5.14 analogue output command .....        | 17 |
| 5.15 fastlink marker command .....        | 17 |
| 6 TERMINATIONS AND CONNECTIONS .....      | 18 |
| 6.1 ANALOGUE OUTPUT PORTS .....           | 19 |
| 6.2 POWER INPUT PORT .....                | 19 |
| 6.3 SILBUS NETWORK PORT .....             | 19 |
| 7 CERTIFICATION .....                     | 20 |
| 7.1 INSTALLATION CONFIGURATION 1 .....    | 21 |
| 7.2 INSTALLATION CONFIGURATION 2 .....    | 22 |
| 8 SOFTWARE REVISION AND DISPLAY .....     | 23 |
| 9 SPECIFICATIONS .....                    | 24 |

## PHOTOGRAPHS

|                                                                        |   |
|------------------------------------------------------------------------|---|
| Photograph 1 SILBUS-RX4A front panel.....                              | 5 |
| Photograph 2 Access to console port and programming switch .....       | 6 |
| Photograph 3 Laptop connected to console port via MEAN1 interface..... | 9 |

## TABLES

|                                                              |    |
|--------------------------------------------------------------|----|
| Table 1 Status LED flash sequence meanings.....              | 8  |
| Table 2 SILBUS-RX4A Configuration record.....                | 18 |
| Table 3 Analogue output termination details .....            | 19 |
| Table 4 Power input port termination details .....           | 19 |
| Table 5 SILBUS network port termination details .....        | 19 |
| Table 6 Installation configuration 1 entity parameters ..... | 21 |
| Table 7 Installation configuration 2 entity parameters ..... | 23 |
| Table 8 SILBUS-RX4A Software revision history .....          | 23 |

## FIGURES

|                                                             |    |
|-------------------------------------------------------------|----|
| Figure 1 SIBUS-RX4A Connection diagram.....                 | 18 |
| Figure 2 SILBUS-RX4A segregation and isolation levels ..... | 20 |
| Figure 3 Installation configuration 1 .....                 | 21 |
| Figure 4 Installation configuration 2 .....                 | 22 |

## 1 GENERAL DESCRIPTION

The four channel analogue receiver is part of a family of explosion protected DIN rail mounting modules that transmit to and receive from an Austdac SILBUS field bus network. The SILBUS-RX4A can receive up to four analogue signals on four independent valid SILBUS channels.

The four analogue outputs are galvanically isolated from the SILBUS network port. This isolation allows the SILBUS-RX4A to provide many simple and highly effective solutions when used in installations involving intrinsically safe and non-intrinsically safe circuits.

The receiver is housed within a DIN rail mounting enclosure measuring 100mm (W) x 75mm (H) x 110mm (D). The front panel is located between the two top of enclosure mounted terminal blocks to provide a clear view of the operation indicating LED's. Two LED's are provided to show power and SILBUS network status.

The SILBUS-RX4A can be quickly and simply configured using a laptop computer running Hyper Terminal and a small plug in programming adaptor. Each analogue output can be independently programmed to any SILBUS channel address. Each analogue output can also have it's under range, hysteresis, digital fault channels and transmission protocol configured by the user.

## 2 FRONT PANEL LAYOUT

The four channel analogue receiver front panel is located between the terminal blocks that form part of the enclosure. The front panel is shown in photograph 1 below.



Photograph 1 SILBUS-RX4A front panel

Located in the top right hand corner of the front panel are the STATUS and POWER indication LED's. The green power LED is illuminated whenever a 12 volt supply is connected to the receiver. The orange status LED flashes at different rates to indicate the operational status of the receiver, see table 2 for more details.

The front panel can be snapped out and removed by using a wide bladed flat screw driver to gain access to the configuration (console) port and programming switch. Photograph 2 below shows the front panel removed and the location of the console port and programming switch.



**Photograph 2 Access to console port and programming switch**

The black four pin console port connector and the red programming switch are located behind the lower right corner of the front panel label.

### **3 THEORY OF OPERATION**

The four channel analogue receiver receives four valid ANALINK or FASTLINK analogue channels and outputs them as a 4-20mA or 0-20mA signal. Each analogue channel is converted from a sixteen bit (Fastlink) or eight bit (Analink) value into a 0-20mA or 4-20mA signal at the output terminals. The transmission protocol can be independently selected for each analogue output. See Austdac document 120-009-10 for a more detailed description of SILBUS communications.

The analogue output circuit is monitored for open circuit or loss of compliance and if one of these conditions should occur a fault condition is generated. This fault can be transmitted

as a digital signal on any valid configurable SILBUS channel address. Compliance is when the SILBUS-RX4A can generate sufficient voltage to force the required signal current into the connected load. Loss of compliance can occur when the input resistance of the load and the signal cable resistance are too high for the required output signal current or when the SILBUS-RX4A power supply voltage is reduced because of resistance in the power supply cable. The following formula calculates the maximum load resistance given the SILBUS-RX4A power supply voltage.

$$R_{L(MAX)} = (U_i - 3.8) / 0.02$$

Where  $R_L$  is the maximum load resistance and  $U_i$  is the voltage at the power supply terminals of the Analogue receiver.

It is important that all installations be checked for output signal compliance using the above formula to ensure correct functionality. Assuming a power supply voltage of 12.6 volts the maximum  $R_L$  is 440 $\Omega$ . If the power supply voltage is at the operating minimum of 7.5 volts the maximum  $R_L$  is 185 $\Omega$ . If the analogue receiver is at the end of long power supply cables then the power supply voltage will alter as a function of cable resistance and influence the compliance of the SILBUS-RX4A.

Should the analogue receiver receive an ANALINK or FASTLINK message that indicates that the analogue transmitter sending the message has detected an out of range input i.e. less than 4mA, then the SILBUS-RX4A will output less than 4mA as well, to indicate to the final monitoring equipment e.g. PLC that the entire signal path from the sensor has a fault that should be rectified.

Should the analogue receiver lose SILBUS communications with an analogue transmitter or source device transmitting using the FASTLINK protocol or if the FASTLINK marker fails or if FASTLINK CRC errors occur, then the SILBUS-RX4A can be configured to carry out one of the following actions using the FSTFLT command;

- Leave the analogue output at the last correctly received value until communications are re-established or,
- Drive the analogue output(s) to zero (0mA) to indicate an open faulty loop or,
- Drive the analogue output(s) to full scale (20mA).

Should the SILBUS be experiencing CRC errors due to noise interference then the FSTFLT command can be used to configure the number of consecutive CRC errors that must be received before the failsafe action is implemented. The failsafe action can be individually configured for the four analogue output channels. The selection of failsafe modes is not available when the ANALINK protocol is selected.

A common alarm or quality digital output can be configured to transmit on any valid SILBUS address whenever something is wrong with an ANALINK or FASTLINK received message.

Whenever the FASTLINK protocol is selected a FASTLINK marker channel or SILBUS channel must be specified. The FASTLINK marker is generated by the Dual Port Channel Generator type GSW1.



All configurable aspects of the four channel analogue receiver can be programmed via the console port. The receiver will operate with 8, 16, 32, 64 and 128 channel SILBUS networks and will automatically configure to the number of channels of the connected SILBUS network.

## 4 OPERATING INSTRUCTIONS

The four channel analogue receiver does not require any operator action to operate once it has been installed within an IP54 host enclosure and configured correctly.

An understanding of the various flash sequences of the orange status LED may be required to help in the trouble shooting and maintenance of the entire SILBUS network installation. The status LED provides information on the operational status of the receiver and the connected SILBUS network. This information includes correct microprocessor operation, health of connected SILBUS network, selection of an invalid SILBUS channel address and indication of software version number. The table below shows the various flash sequences and their meaning.

| STATUS LED FLASH SEQUENCES                                            |                           |                                                                                                                                                                                                                                             |
|-----------------------------------------------------------------------|---------------------------|---------------------------------------------------------------------------------------------------------------------------------------------------------------------------------------------------------------------------------------------|
| FLASH SEQUENCE                                                        | NAME                      | MEANING                                                                                                                                                                                                                                     |
| NONE – LED ON OR OFF CONTINUOUSLY                                     | NO FLASH                  | INTERNAL MICROPROCESSOR FAULT OR NO POWER.                                                                                                                                                                                                  |
| 3 SECONDS ON<br>3 SECONDS OFF                                         | SLOW FLASH                | RECEIVER FUNCTIONING – NO SILBUS CONNECTED TO SILBUS PORT.                                                                                                                                                                                  |
| 1 SECOND ON<br>1 SECOND OFF                                           | FAST FLASH                | RECEIVER FUNCTIONING – HEALTHY SILBUS CONNECTED TO SILBUS PORT.                                                                                                                                                                             |
| LONG PERIOD OFF FOLLOWED BY 3 SHORT FLASHES                           | PAUSE – 3 SHORT FLASH     | AN ANALOGUE OUTPUT OR FAULT SIGNAL HAS BEEN ASSIGNED TO AN INVALID SILBUS CHANNEL ADDRESS I.E. P8 FOR A 64 CHANNEL SILBUS NETWORK. AN ANALOGUE OUTPUT HAS BEEN CONFIGURED TO FASTLINK AND A FASTLINK MARKER ADDRESS HAS NOT BEEN SPECIFIED. |
| LONG PERIOD OFF FOLLOWED BY 5 SHORT FLASHES                           | PAUSE – 4 SHORT FLASH     | ONE OR MORE FASTLINK CHANNELS SELECTED BUT NO FASTLINK MARKER ADDRESS ASSIGNED                                                                                                                                                              |
| LONG PERIOD OFF FOLLOWED BY 5 SHORT FLASHES                           | PAUSE – 5 SHORT FLASH     | ONE OR MORE FASTLINK CHANNELS HAS DETECTED AN CRC ERROR OR BAD FASTLINK MARKER OR ONE OR MORE ANALINK CHANNELS HAS A RECEIVED VALUE OF ZERO                                                                                                 |
| LONG PERIOD OFF FOLLOWED BY 6 SHORT FLASHES                           | PAUSE – 6 SHORT FLASH     | ONE OR MORE ANALOGUE OUTPUT CIRCUITS ARE OPEN CIRCUIT OR OUT OF COMPLIANCE.                                                                                                                                                                 |
| MAJOR REVISION FLASH SEQUENCE – PAUSE – MINOR REVISION FLASH SEQUENCE | SOFTWARE VERSION SEQUENCE | INDICATES THE SOFTWARE VERSION LEVEL IMMEDIATELY AFTER POWER UP. SEE SOFTWARE REVISION SECTION OF THIS MANUAL FOR DETAILS.                                                                                                                  |

**Table 1 Status LED flash sequence meanings**

The console port power source selection switch SW1 must always be in the run position for correct operation of the receiver. The run position is with the small slide actuator pushed furthest away from the black four pin console connector X111.



## 5 CONFIGURATION

The four channel analogue receiver has several operational parameters that require configuration prior to use. All of these parameters can be viewed and changed via the console port. The console port consists of a small four pin connector and a two position slide switch behind the front panel label. Access to the console port can be gained by snapping out the front panel using a wide bladed flat screw driver in one of the slots between the front panel and terminal blocks.

To use the console port an Austdac MEAN1 interface, A to B USB cable and laptop computer running Hyper Terminal are required.

For more detail on the console port, MEAN1 interface and their use refer to Austdac document 53-018-12.

### 5.1 CONSOLE PORT OPERATION

The console port should be connected to a laptop running a terminal emulation program such as Hyper Terminal via the Austdac interface type MEAN1 and a USB cable as shown in the following photograph.



**Photograph 3 Laptop connected to console port via MEAN1 interface**

The SILBUS-RX4A certification places restrictions on what may be connected to the console port, the connection of an interface other than the Austdac MEAN1 to the console port will invalidate the certification of the receiver.



The terminal emulation program should be configured to 19200 baud, 8 data bits, one stop bit, no parity, no flow control and DEC VT100 terminal emulation.

Once communications have been established with the SILBUS-RX4A, it will display a screen of information that includes software version, software checksum, and a list of commands followed by the console port prompt.

The prompt includes an abbreviation of the receiver type number. **RX4A: :>**

Commands are invoked by entering the command name followed by any optional modifiers, keywords and the “ENTER” key. The enter key is shown in the following examples as a “←” symbol.

## 5.2 HELP COMMAND

The HELP command prints a list of all available commands and shows the syntax for each command. Optional command modifiers are shown within [ ] while mandatory modifiers are shown within < >. An example of a screen output follows:

```
RX4A: :>HELP ←
```

```
Software 1V01 0x4AAF Configuration 0x33DF SN:09031000
Commands:
```

```
-----
                ***** Level 1: Standard Menu *****
HELP           [1..7] Level of Help                Displays Help Menu
REPEAT         [LF] [Refresh rate in seconds]      Repeats Previous Command
VER            Displays Firmware Version and Checksum
STACK          Displays Peak Stack Usage
SBMAP          Displays SILBUS I/O Map
SBSTAT        Displays SILBUS Status
SBGET          <A1-P8>                             Display selected SILBUS Channel State
SBADDR        [<SET> <ANA O/P> <A1-P8, DISABLE>]   Set ANA O/P Address
SBFALT        [<SET> <ANA O/P> <A1-P8 or DISABLE>] Set Fault Address
SBQUAL        [<SET> <A1-P8, DISABLE>]           Analink/Fastlink Quality Add
ANASEL        [<SET> <ANA O/P> <ANALINK|FASTLINK>] Set Analog Protocol
AOUT          Display Analogue Output Values
FSTMRK        [<SET> <A1-P8, DISABLE>]           Set Fastlink Marker Address
FSTFLT        [<SET> [Count] [ZERO|FULL|HOLD]]     Failsafe mode
PWD           <4 Digit Password>                 Password for Factory Menus
-----
```

```
RX4A: :>_
```

## 5.3 REPEAT COMMAND

The REPEAT command is used after another command to continuously repeat that command. As an example the SBGET command can be executed followed by the

REPEAT command to provide a continuously updating display of the selected SILBUS channel. The display will continue to update until any key is hit. The TX4A will respond by displaying the prompt.

```
RX4A: :>SBGET D1 ↵  
D1 = ON
```

```
RX4A: :>REPEAT  
D1 = OFF ↵
```

```
RX4A: :>_
```

In the above example the “OFF” changed to an “ON” whenever SILBUS channel D1 was activated. In this mode the repeat command writes over the previously displayed information, if required, the repeat command can be made to refresh the information on a new line by entering LF (line feed) as part of the command invocation. The repeat command refreshes the display every one second by default. The refresh rate can be slowed by entering the refresh rate in seconds as part of the repeat command as shown in the following command:

```
RX4A: :>REPEAT LF 5 ↵  
D1 = OFF  
D1 = OFF  
D1 = ON  
D1 = OFF  
D1 = OFF  
D1 = ON  
D1 = OFF ↵
```

```
RX4A: :>_
```

As can be seen from the above example the repeat command refreshed the status of SILBUS channel D1 on a new line every five seconds. In the LF mode a record of the status of D1 can be viewed on the screen.

## 5.4 VERSION COMMAND

The VERSION command is used to display the serial number, abbreviated type number, software version and program memory checksum of the RX4A. The command can be invoked as shown in the following example:

```
RX4A: :>VER ↵  
Software 1V01 0x4AAF Configuration 0x33DF SN:09031000
```

```
RX4A: :>_
```

This command is useful when the user needs to know the software version or serial number. The program memory checksum is useful to confirm that a software update has completed successfully without any programming errors.

## 5.5 STACK COMMAND

The STACK command is provided to allow the technician to gauge the health of the RX4A microprocessor and its code by displaying the maximum usage of the program stack. The display is a peak value of the stack usage since the RX4A was powered up. The command can be invoked as shown in the example below:

```
RX4A::>STACK ↵  
Stack usage/size = 312/1024  
Percentage Used = 30%
```

```
RX4A::>_
```

This command would typically only be used when requested by an Austdac software engineer.

## 5.6 SILBUS MAP COMMAND

The SILBUS map command allows the operator to obtain a snapshot of the SILBUS network to which the receiver is connected. The map shows all of the SILBUS channels available on the network. The map consists of a table with a heading of groups below which is displayed the channels using ones and zeros. Each group is shown vertically with 1 at the top and 8 at the bottom. A one indicates an ON channel and a zero indicates an OFF channel. An example of an SBMAP is shown below with channels A4, P7 and P8 on or active:

```
RX4A::>SBMAP ↵  
ABCDEFGHIJKLMNPO  
0000000000000000  
0000000000000000  
0000000000000000  
1000000000000000  
0000000000000000  
0000000000000000  
0000000000000001  
0000000000000001
```

```
rX4A::>_
```

The SBMAP command is particularly useful when used with the repeat command as this will display a continuously updated table.

## 5.7 SILBUS STATUS COMMAND

The SILBUS status command displays the number of SILBUS channels available on the connected SILBUS network, a SILBUS synchronisation pulse count and a SILBUS error count. This command is used to determine if the connected SILBUS network is functioning correctly and how many channels are available. The error count should typically be zero while the sync count should be incrementing. Once again the use of the repeat command will provide a dynamic updating display. An example of the SBSTAT command follows:

```
RX4A::>SBSTAT ↵  
No. Chan = 128, Sync Count = 17807, Error Count = 0
```

```
RX4A::>_
```

The error count will be non zero whenever the connected SILBUS network is out of specification. The error count can be non zero if the connected SILBUS network channel generator has its power supply cycled off and on. These error counts should be ignored.

## 5.8 SILBUS GET COMMAND

The SILBUS get command is used to display the status of one selected SILBUS channel only. If this command is used in conjunction with the repeat command a continuously updating display can be achieved. The command is invoked by entering the command name followed by the desired channel address as shown in the two examples below:

```
RX4A::>SBGET M3 ↵  
M3 = OFF
```

```
RX4A::>SBGET B7 ↵  
B7 = ON
```

```
RX4A::>_
```

## 5.9 ANALOGUE OUTPUT ADDRESS COMMAND

This command is used to display and configure the SILBUS channel addresses of the four analogue outputs of the SILBUS-RX4A. The current SILBUS channels can be displayed by simply entering the command name as shown in the example below:

```
RX4A::>SBADDR ↵  
Silbus Output Addresses are:  
Output 1 Address = J2  
Output 2 Address = A6  
Output 3 Address = A7  
Output 4 Address = B3
```

```
RX4A::>_
```

If the command name is entered with additional attributes the channel addresses can be configured to any valid SILBUS address. There is no restriction on the SILBUS addresses; they do not have to be in numerical order or from the same group. An example of configuring output 2 is shown below:

```
RX4A::>SBADDR SET 2 K7 ↵  
Setting Changed  
Output 1 Address = J2  
Output 2 Address = K7
```

**Output 3 Address = A7**  
**Output 4 Address = B3**

**RX4A::>\_**

The above example shows the format of the command when the address is configured. The keyword “SET” is required to invoke a change; the number of the RX4A output is next, followed by the SILBUS channel address. If a RX4A output is not to be used then it should not be assigned a SILBUS channel address. The keyword “DISABLE” is used when a SILBUS channel is not required.

```
RX4A::>SBADDR SET 2 DISABLE ↵  
Setting Changed  
Output 1 Address = J2  
Output 2 Address = DISABLE  
Output 3 Address = A7  
Output 4 Address = B3
```

**RX4A::>\_**

## 5.10 FAULT ADDRESS COMMAND

This command is used to display and configure the SILBUS channel addresses of the four signal fault signals of the SILBUS-RX4A. The fault signals are generated when an analogue output falls out of compliance. The current SILBUS channels of the fault signals can be displayed by simply entering the command name as shown in the example below:

```
RX4A::>SBFALT ↵  
4-20mA loop fault SILBUS addresses are:  
Channel [1] Fault Address = J2  
Channel [2] Fault Address = A6  
Channel [3] Fault Address = A7  
Channel [4] Fault Address = DISABLE
```

**RX4A::>\_**

If the command name is entered with additional attributes the channel addresses can be configured to any valid SILBUS address. There is no restriction on the SILBUS addresses; they do not have to be in numerical order or from the same group. An example of configuring output 2 is shown below:

```
RX4A::>SBFALT SET 2 K7 ↵  
Setting Changed  
Channel [1] Fault Address = J2  
Channel [2] Fault Address = K7  
Channel [3] Fault Address = A7  
Channel [4] Fault Address = B3
```

**RX4A::>\_**

The above example shows the format of the command when the address is configured. The keyword “SET” is required to invoke a change; the number of the RX4A output is next, followed by the SILBUS channel address. If a RX4A output is not to be used then it should not be assigned a SILBUS channel address. The keyword “DISABLE” is used when a SILBUS channel is not required.

```
RX4A::>SBFALT SET 2 DISABLE ↵  
Setting Changed  
Channel [1] Fault Address = J2  
Channel [2] Fault Address = DISABLE  
Channel [3] Fault Address = A7  
Channel [4] Fault Address = B3
```

```
RX4A::>_
```

### 5.11 FAULT LEVEL COMMAND

This command is used to display and configure the under level fault trigger point for each of the analogue outputs. The fault trigger point allows the analogue receiver to detect output signals that are out of range (less than 4mA) or open circuit. The fault level is entered as a mA level for example 3.80. This would cause a fault to be generated whenever the output signal fell below 380mV for a 0.4 to 2.0V output signal or 3.80mA for a 4 to 20mA signal. The current fault levels can be displayed by simply entering the command name as shown in the example below:

```
TX4A::>FLTLEV ↵  
Output [1] = 3.99mA  
Output [2] = 4.00mA  
Output [3] = 3.90mA  
Output [4] = 3.85mA
```

If the command name is entered with additional attributes the fault levels can be configured to any valid level. An example of configuring the fault level for output 2 is shown below:

```
TX4A::>FLTLEV SET 2 3.95 ↵  
Setting Changed  
Output [1] = 3.99mA  
Output [2] = 3.95mA  
Output [3] = 3.90mA  
Output [4] = 3.85mA
```

### 5.12 FAULT HYSTERESIS COMMAND

This command is used to display and configure the under level fault trigger point hysteresis for each of the analogue outputs. The hysteresis value is used to stop the fault signal from switching on and off with any noise that may be present on the analogue output signal. For example if the analogue output was currently at 4.00mA and the fault level was set at 3.99mA, the output signal would only need slightly more than 0.01mA of



noise to cause the fault signal to randomly switch on and off. By setting the hysteresis value to slightly higher than any known noise this random and annoying switching can be eliminated. The hysteresis value is common to all four analogue outputs. The current hysteresis value can be displayed by simply entering the command name as shown in the example below:

```
TX4A::>FLTHYS ←  
Hysteresis level 0.10mA
```

```
TX4A::>_
```

If the command name is entered with additional attributes the hysteresis level can be configured to any valid level. An example of configuring the hysteresis level is shown below:

```
TX4A::>FLTHYS SET 0.21 ←  
Setting Changed  
Hysteresis level 0.21mA
```

```
TX4A::>_
```

The range of the hysteresis is from 0.01mA to 1.00mA.

### 5.13 ANALOGUE SELECT COMMAND

This command is used to display and configure the analogue transmission protocol for each of the analogue outputs. Each analogue output can be configured to either Analink or Fastlink. The current selected transmission protocols can be displayed by simply entering the command name as shown in the example below:

```
RX4A::>ANASEL ←  
Chan[1] = Analink  
Chan[2] = Analink  
Chan[3] = Analink  
Chan[4] = Analink
```

```
RX4A::>_
```

If the command name is entered with additional attributes the analogue transmission protocol can be configured to Fastlink or Analink for each analogue output. An example of configuring output 1 is shown below:

```
RX4A::>ANASEL SET 1 FASTLINK ←  
Setting Changed  
Chan[1] = Fastlink (Marker Error)  
Chan[2] = Analink  
Chan[3] = Analink  
Chan[4] = Analink
```

**RX4A::>\_**

The 'marker error' has been displayed because analogue output one has been configured to Fastlink but a valid Fastlink marker channel address has not been specified. See the Fastlink marker command (FSTMRK) for details on assigning a valid marker address. Once a valid marker address has been configured the error message will disappear as shown in the example below.

```
RX4A::>ANASEL ←  
Chan[1] = Fastlink  
Chan[2] = Analink  
Chan[3] = Analink  
Chan[4] = Analink
```

**RX4A::>\_**

## 5.14 ANALOGUE OUTPUT COMMAND

The analogue output command is used to display the current value of all the analogue outputs. The example below shows analogue output 3 being displayed:

```
RX4A::>AOUT ←  
Chan[1] = 12.230mA
```

**RX4A::>\_**

If the output attribute is omitted from the command then the last displayed output will be displayed again. If the analogue output command has not been used since power up and the output attribute is omitted from the command then output one will be displayed by default.

## 5.15 FASTLINK MARKER COMMAND

This command is used to display and configure the FASTLINK marker SILBUS channel address. A valid FASTLINK marker is required whenever any one of the analogue outputs is configured to transmit using the FASTLINK protocol. The marker is generated by the GSW1 channel generator and can be any valid SILBUS channel address. Only one marker is required per SILBUS field bus network. The current marker channel address can be displayed by simply entering the command name as shown in the example below:

```
RX4A::>FSTMRK ←  
Fastlink Marker SILBUS Address is A3
```

**RX4A::>\_**

The example below shows the format of the command when the marker address is configured. The keyword "SET" is required to invoke a change, followed by the SILBUS channel address of the FASTLINK marker. If FASTLINK is not to be used by the TX4A receiver then the marker channel should be disabled. The keyword "DISABLE" is used when the marker channel is not required.

```
RX4A::>FSTM RK SET DISABLE ↵
Setting Changed
Fastlink Marker SILBUS Address is DISABLE
```

```
RX4A::>_
```

The following table may be used to record the configuration of the SILBUS-RX4A four channel analogue receiver.

| SILBUS-RX4A CONFIGURATION RECORD       |   |   |   |   |
|----------------------------------------|---|---|---|---|
| LOCATION                               |   |   |   |   |
| SILBUS NETWORK                         |   |   |   |   |
| CHANNEL                                | 1 | 2 | 3 | 4 |
| OUTPUT SIGNAL TYPE                     |   |   |   |   |
| ANALOGUE SILBUS CHANNEL ADDRESS        |   |   |   |   |
| FAULT SILBUS CHANNEL ADDRESS           |   |   |   |   |
| FAULT LEVEL (mA)                       |   |   |   |   |
| FAULT HYSTERESIS                       |   |   |   |   |
| ANALOGUE TRANSMISSION TYPE             |   |   |   |   |
| FASTLINK MARKER SILBUS CHANNEL ADDRESS |   |   |   |   |

Table 2 SILBUS-RX4A Configuration record

## 6 TERMINATIONS AND CONNECTIONS

All connections to the four channel analogue receiver are via cage-clamp terminals around the perimeter and near the front of the DIN rail mounting enclosure, these terminals can accommodate up to 4mm<sup>2</sup> conductors. There are 12 possible connections to the receiver; these are shown in the following tables and diagrams:

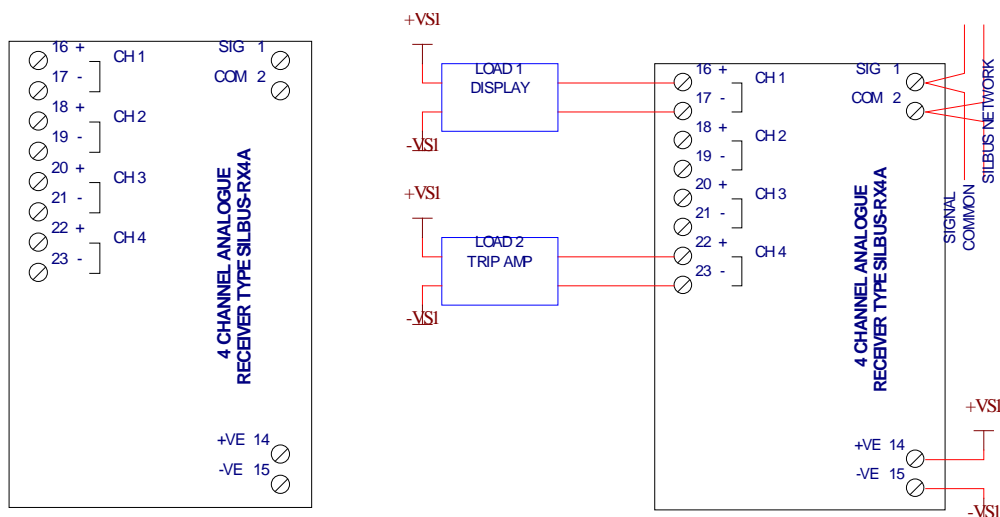

Figure 1 SILBUS-RX4A Connection diagram

## 6.1 ANALOGUE OUTPUT PORTS

Each analogue output is provided with two terminals for the connection of field wiring. Each output is a 0-20mA or 4-20mA output. The output compliance is dependent on the power supply voltage. With a power supply of 12.6 volts the maximum RL (including the cable) is 440Ω and if the power supply voltage is at the operating minimum of 7.5 volts the maximum RL (including the cable) is 185Ω.

| ANALOGUE OUTPUT TERMINATIONS |        |         |                      |
|------------------------------|--------|---------|----------------------|
| OUTPUT                       | TERM # | LABEL   | DESCRIPTION          |
| CH1                          | 16     | CH1_+IN | CHANNEL 1 +VE OUTPUT |
|                              | 17     | CH1_-IN | CHANNEL 1 -VE OUTPUT |
| CH2                          | 18     | CH2_+IN | CHANNEL 2 +VE OUTPUT |
|                              | 19     | CH2_-IN | CHANNEL 2 -VE OUTPUT |
| CH3                          | 20     | CH3_+IN | CHANNEL 3 +VE OUTPUT |
|                              | 21     | CH3_-IN | CHANNEL 3 -VE OUTPUT |
| CH4                          | 22     | CH4_+IN | CHANNEL 4 +VE OUTPUT |
|                              | 23     | CH4_-IN | CHANNEL 4 -VE OUTPUT |

**Table 3 Analogue output termination details**

The analogue outputs are galvanically isolated from the SILBUS network port; this allows the SILBUS-RX4A to be used in a variety of special ways that include connecting non-intrinsically safe signals to the analogue outputs while the receiver is connected to an intrinsically safe SILBUS network.

## 6.2 POWER INPUT PORT

The four channel analogue receiver operates from a nominal 12 volt DC supply. The power supply operating range is from 7.5 volts through to 12.6 volts. The SILBUS-RX4A consumes less than 12mA from the power supply. The table below shows the power input port connection details.

| POWER INPUT PORT TERMINATIONS |             |                                  |
|-------------------------------|-------------|----------------------------------|
| TERMINAL                      | DESIGNATION | DESCRIPTION                      |
| 14                            | +VE 12V     | POWER SUPPLY +VE INPUT           |
| 15                            | -VE 12V     | POWER SUPPLY -VE OR COMMON INPUT |

**Table 4 Power input port termination details**

## 6.3 SILBUS NETWORK PORT

The SILBUS network port provides a means for the receiver to be connected to a SILBUS network. Any connections to a SILBUS field bus network pair should be of a multi-drop nature with spur lengths kept to a minimum. This will minimize any reflections and therefore communications errors in the SILBUS network.

| SILBUS NETWORK PORT TERMINATIONS |             |                       |
|----------------------------------|-------------|-----------------------|
| TERMINAL                         | DESIGNATION | DESCRIPTION           |
| 1                                | SIG         | SILBUS NETWORK SIGNAL |
| 2                                | COM         | SILBUS NETWORK COMMON |

**Table 5 SILBUS network port termination details**

The table above shows the SILBUS network port connections.

## 7 CERTIFICATION

The four channel analogue receiver type SILBUS-RX4A has been awarded IECEx certification under IECEx TSA 07.0002X, Ex ia I, as part of the Dupline / SILBUS system.

The certification requires that the SILBUS-RX4A be mounted within a host enclosure that provides a minimum ingress protection of IP54 (IP55 for Queensland Australia).

Because of the segregation and isolation between the analogue outputs and the SILBUS network port the SILBUS-RX4A may be used in two different installation configurations that offer considerable flexibility in its application when dealing with intrinsically safe and non-intrinsically safe circuits. As shown in the figure below the SILBUS network port is segregated from the other ports to IEC60079-11 375 volts as indicated by the green dotted lines. The four analogue output channels are segregated from each other but not galvanically isolated.

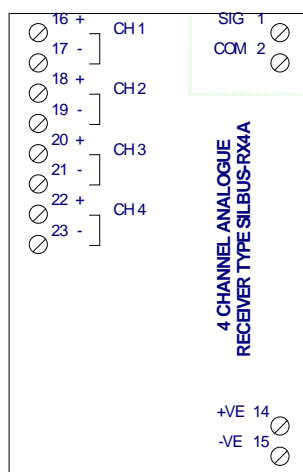

**Figure 2 SILBUS-RX4A segregation and isolation levels**

The analogue output terminals are separated from all other terminals by more than 50mm. The individual analogue output channels are separated from each other by more than 6mm.

These segregations and separations combine to allow the following installation configurations:

- Configuration 1 – Installation within the hazardous area with connection of only intrinsically safe circuits.
- Configuration 2 – Installation within the safe area with connection of an intrinsically safe SILBUS network. Powered from a non-intrinsically safe power supply and connection of non-intrinsically safe analogue outputs.

Careful attention should be paid to the segregation of wiring in all of these configurations as incorrectly segregated wiring could negate the segregation and safety of the receiver.

## 7.1 INSTALLATION CONFIGURATION 1

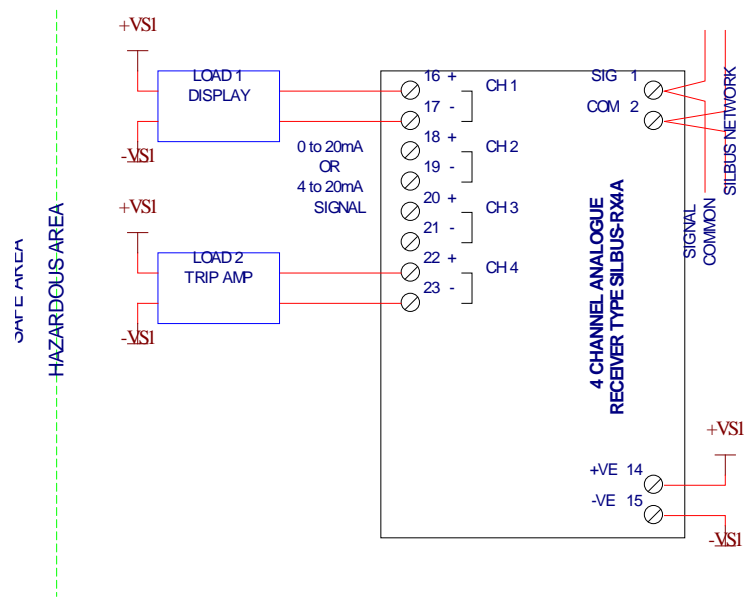

**Figure 3 Installation configuration 1**

This configuration allows the four channel analogue receiver to be located wholly within the hazardous area and the connection of intrinsically safe circuits to its various ports. The analogue outputs can be driven from a single or four different intrinsically safe sources because of the segregation between the four analogue output channels. For the same reason the power supply port can be driven from the same source as the analogue outputs or from an entirely different intrinsically safe source without the need for an assessment of voltage or current addition.

| INSTALLATION CONFIGURATION 1 ENTITY PARAMETERS |                      |                  |            |             |              |
|------------------------------------------------|----------------------|------------------|------------|-------------|--------------|
| PARAMETER                                      | DESCRIPTION          | ANALOGUE OUTPUTS | POWER PORT | SILBUS PORT | CONSOLE PORT |
| Ui                                             | Max input voltage    | 30 volts         | 12.6 volts | 12.6 volts  |              |
| Ii                                             | Max input current    | 3.3 amps         | 3.3 amps   | 3.3 amps    |              |
| Li                                             | Input inductance     | 0uH              | 0uH        | 0uH         |              |
| Ci                                             | Input capacitance    | 0uF              | 0uF        | 0uF         |              |
| Uo                                             | Max output voltage   | 0 volts          | 0 volts    | 0 volts     |              |
| Io                                             | Max output current   | -                | -          | -           |              |
| Lo                                             | Max load inductance  | -                | -          | -           |              |
| Co                                             | Max load capacitance | -                | -          | -           |              |
| Lo/Ro                                          | Max cable L/R        | -                | -          | -           |              |

**Table 6 Installation configuration 1 entity parameters**

The table above lists the entity parameters awarded to the receiver by its certification for this configuration, these parameters would need to be taken into account when conducting an installation assessment in accordance with IEC60079-25.

As always, careful attention should be paid to the segregation of wiring in this configuration as incorrectly segregated wiring could negate the segregation and safety of the receiver.

## 7.2 INSTALLATION CONFIGURATION 2

This configuration allows the four channel analogue receiver to be located wholly within the safe area, the connection of an intrinsically safe SILBUS network, be powered from a non-intrinsically safe power supply and the connection of non-intrinsically safe analogue outputs. This configuration is possible because of the segregation and isolation between the SILBUS network port and the remainder of the receiver.

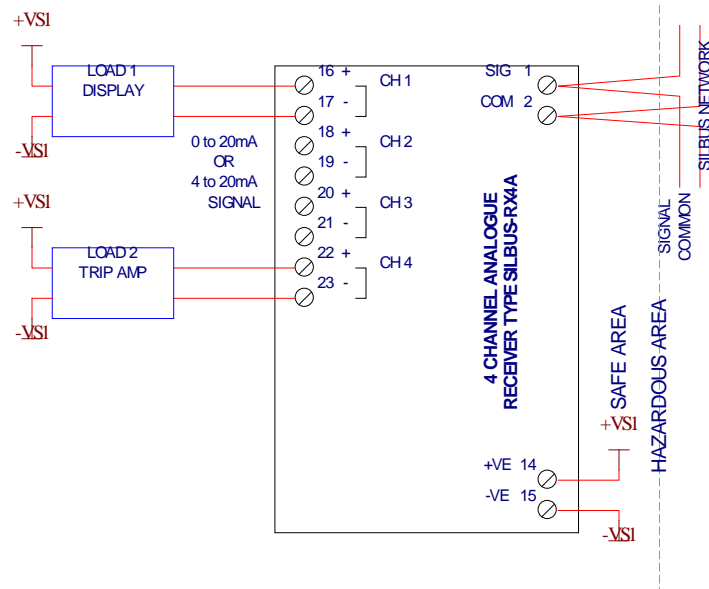

**Figure 4 Installation configuration 2**

This configuration allows an intrinsically safe SILBUS network to be interfaced with non-intrinsically safe analogue outputs. This is particularly useful in the monitoring of tripper drives in underground conveyor installations.

Obviously the segregation of the intrinsically safe SILBUS network is of paramount importance in this configuration. Incorrectly segregated SILBUS network wiring could negate the segregation and safety of the receiver and the entire SILBUS network installation.



| INSTALLATION CONFIGURATION 2 ENTITY PARAMETERS |                           |                  |                  |             |              |
|------------------------------------------------|---------------------------|------------------|------------------|-------------|--------------|
| PARAMETER                                      | DESCRIPTION               | ANALOGUE OUTPUTS | POWER PORT       | SILBUS PORT | CONSOLE PORT |
| Ui                                             | Max input voltage         | -                | -                | 12.6 volts  |              |
| Ii                                             | Max input current         | -                | -                | 3.3 amps    |              |
| Li                                             | Input inductance          | -                | -                | 0uH         |              |
| Ci                                             | Input capacitance         | -                | -                | 0uF         |              |
| Uo                                             | Max output voltage        | -                | -                | 0 volts     |              |
| Io                                             | Max output current        | -                | -                | -           |              |
| Lo                                             | Max load inductance       | -                | -                | -           |              |
| Co                                             | Max load capacitance      | -                | -                | -           |              |
| Lo/Ro                                          | Max cable L/R             | -                | -                | -           |              |
| Um                                             | Maximum non I.S. voltage  | 250 volts        | 12.6             | -           | 5.88 volts   |
| Un                                             | Nominal operating voltage | 5 – 30 volts     | 7.5 – 12.6 volts | -           | -            |

**Table 7 Installation configuration 2 entity parameters**

## 8 SOFTWARE REVISION AND DISPLAY

The software version of the four channel analogue receiver type SILBUS-RX4A will vary as its functionality is improved at the request of our customers. The software version is given in two parts, the major revision level and the minor revision level and is written in the following format:

**VERSION M.mm** where M represents the major revision level and mm represents the minor revision level. E.g. VER 1.12

The software version can be determined by using the console port or by watching the orange status LED immediately after power up. The software version will be indicated by a sequence of longer flashes for the major revision level, a long pause to indicate the decimal point and a further sequence of shorter flashes representing the minor revision level.

Therefore software version 1.12 would be represented by the sequence “one longer flash, a long pause, followed by 12 shorter flashes”.

The following table records the software revision history of the SILBUS-RX4A receiver.

| SILBUS-RX4A SOFTWARE REVISION HISTORY |            |                                         |
|---------------------------------------|------------|-----------------------------------------|
| VERSION                               | DATE       |                                         |
| VER 1.01B                             | 2009.02.01 | BETA RELEASE FOR ENGINEERING FINAL TEST |
| VER1.01                               | 2009.03.01 | FIRST PRODUCTION RELEASE                |
|                                       |            |                                         |
|                                       |            |                                         |
|                                       |            |                                         |
|                                       |            |                                         |

**Table 8 SILBUS-RX4A Software revision history**



## 9 SPECIFICATIONS

|                                                            |                                                        |
|------------------------------------------------------------|--------------------------------------------------------|
| Name .....                                                 | 4 Channel Analogue Receiver                            |
| Type.....                                                  | SILBUS-RX4A                                            |
| Number of analogue channels .....                          | 4                                                      |
| Analogue output current signal range.....                  | 0 – 20mA or 4 – 20mA                                   |
| Analogue input transmission protocol.....                  | FASTLINK or ANALINK                                    |
| Terminations .....                                         | Cage clamp 4mm <sup>2</sup> maximum                    |
| Size.....                                                  | 100mm (W) x 75mm (H) x 110mm (D)                       |
| Mass .....                                                 | 300g                                                   |
| Fixing .....                                               | TS35 DIN rail or screw mount M4 on 85mm x 61mm centres |
| Ingress protection .....                                   | IP20                                                   |
| Enclosure material .....                                   | Polycarbonate (30%GV) UL 94 V-1                        |
| Enclosure colour .....                                     | RAL 7032 Grey                                          |
| Terminal material .....                                    | Polycarbonate UL 94 V-2                                |
| Terminal block colour.....                                 | Blue                                                   |
| Operating temperature range.....                           | 0°C to 40°C                                            |
| Storage temperature range .....                            | -20°C to 80°C                                          |
| Operating relative humidity range .....                    | 10% to 90% Non condensing                              |
| Power supply operating voltage range .....                 | 7.5v to 12.6v                                          |
| Power supply current consumption (no output current) ..... | 12mA maximum                                           |
| Additional power supply current for output channels .....  | 0 – 20mA max per channel                               |