

IMPORTANT SAFETY INFORMATION. READ AND FOLLOW ALL SAFETY INSTRUCTIONS. Follow label information and instructions concerning Wet or Damp Locations, installation near combustible materials, insulation, building materials, and proper lamping. Do not install in areas subject to combustible vapors or gases. Before wiring to power supply and during servicing or relamping, turn off power at fuse or circuit breaker. **All servicing or relamping must be performed by qualified service personnel. Product must be grounded to avoid potential electric shock or other potential hazard. Product must be mounted in locations and at heights and in a manner consistent with its intended use, and in compliance with the National Electrical Code and local codes.** The use of accessory equipment not recommended by the manufacturer or installed contrary to instructions may cause an unsafe condition. Do not block light emanating from product in whole or part, as this may cause an unsafe condition. Do not allow items such as drapes, curtains, screens or the like to come into contact with the product or to block light from the product, as this may cause an unsafe condition.

INSTALLATION INSTRUCTIONS ARCHITRAK® SYSTEM

INSTALLATION INSTRUCTIONS

FOR AKTTSK TRACK STEM COVER

FOR USE WITH PRESCOLITE AKT ONE/TWO CIRCUIT TRACK SYSTEM ONLY

READ INSTALLATION INSTRUCTIONS BEFORE INSTALLING THE TRACK SYSTEM

SAVE INSTRUCTIONS FOR REFERENCE WHEN MAKING ADDITIONS TO OR CHANGES IN THE TRACK SYSTEM.

INSTALLATION

1. Refer to PRESCOLITE AKT series track for track installation instructions
2. Assemble stem to "Plate Assembly" with two locknuts. Position the "Plate Assembly" on the T-bar and rotate clockwise to secure "fingers" onto the bar. Slide 4-1/2" square canopy up stem. Secure to plate assembly with one screw and circular.
3. Assemble Z bracket to track rail with screws provided through slots provided at ends or middle of track.
4. Slide plastic cover up stem. Secure stem to Z bracket with two locknuts provided. Slide cover down over Z bracket assembly.

WHEN STEM KIT IS USED AS A POWER FEED YOU MUST USE AN AKTTSK WH OR AKTTSK BL TRACK STEM WIRE COVER. INSTALL AS FOLLOWS:

1. Run suitable black, white and green code gauge wire through stems. Be sure to allow at least 10" of wire for wiring to connector. See wiring instructions provided with connectors AKTEF, AKTT, AKTSL.
2. Connect black stem wire to hot wire (usually black). White to white neutral. Green to green or bare copper ground wire. Use approved connectors (wirenuts).
3. Discard plastic stem cover, replace stem wire cover.
4. See notes 1, 2, 3, 4, and diagram below for stem assembly.

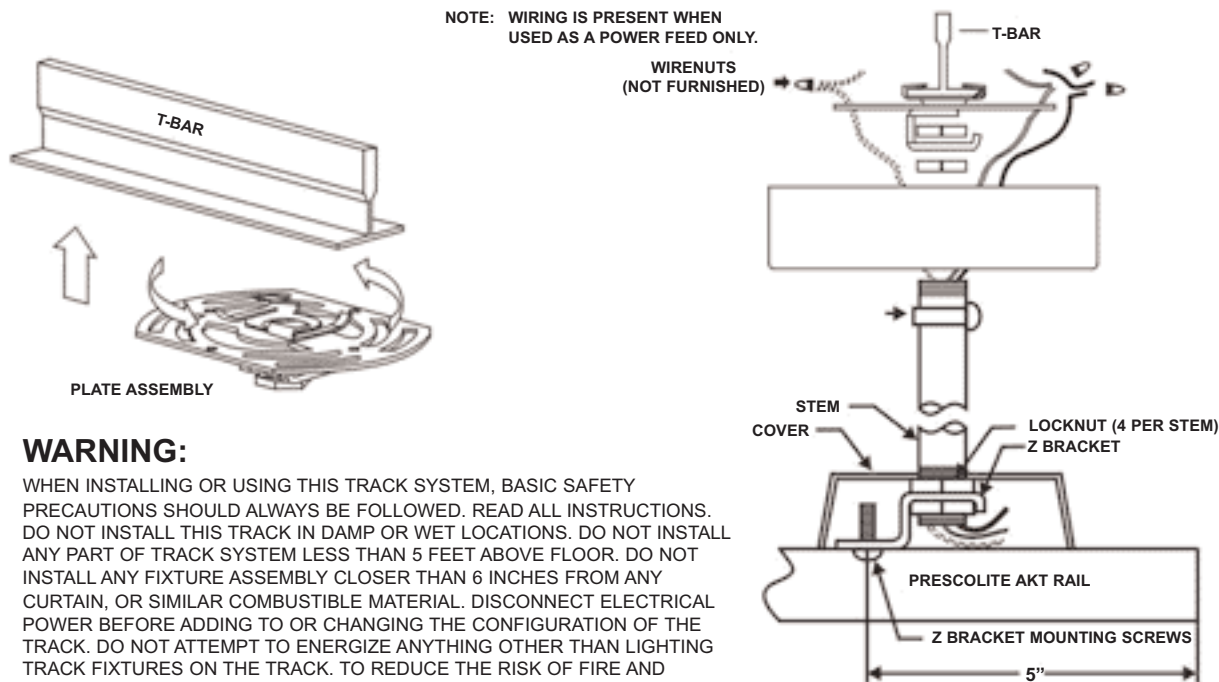

WARNING:

WHEN INSTALLING OR USING THIS TRACK SYSTEM, BASIC SAFETY PRECAUTIONS SHOULD ALWAYS BE FOLLOWED. READ ALL INSTRUCTIONS. DO NOT INSTALL THIS TRACK IN DAMP OR WET LOCATIONS. DO NOT INSTALL ANY PART OF TRACK SYSTEM LESS THAN 5 FEET ABOVE FLOOR. DO NOT INSTALL ANY FIXTURE ASSEMBLY CLOSER THAN 6 INCHES FROM ANY CURTAIN, OR SIMILAR COMBUSTIBLE MATERIAL. DISCONNECT ELECTRICAL POWER BEFORE ADDING TO OR CHANGING THE CONFIGURATION OF THE TRACK. DO NOT ATTEMPT TO ENERGIZE ANYTHING OTHER THAN LIGHTING TRACK FIXTURES ON THE TRACK. TO REDUCE THE RISK OF FIRE AND ELECTRIC SHOCK, DO NOT ATTEMPT TO CONNECT POWER TOOLS, EXTENSION CORDS, APPLIANCES, AND THE LIKE TO THE TRACK.

SAVE THESE INSTRUCTIONS



® 101 Corporate Drive • Spartanburg, SC 29303
With representatives offices in principal cities throughout North America.
Copyright 2005, 08/05 revision, All Rights Reserved - Printed in U.S.A.