

PRECAUTIONS

- Read and understand all instructions before beginning installation.
- **NOTICE:** For installation by a licensed electrician in accordance with National and/or local Electrical Codes and the following instructions.
- Disconnect switch or a circuit breaker must be provided and marked as the disconnecting device.
- Disconnect switch / circuit breaker must be within reach of operator.
- **CAUTION: RISK OF ELECTRICAL SHOCK.** Turn power off at service panel before beginning installation. Never wire energized electrical components.
- **CAUTION: USE COPPER CONDUCTOR ONLY**
- Confirm device ratings are suitable for application prior to installation. Use of device in applications beyond its specified ratings or in applications other than its intended use may cause an unsafe condition and will void manufacturer's warranty.
- Use only approved materials and components (i.e. wire nuts, electrical box, etc.) as appropriate for installation
- **NOTICE:** Do not install if product appears to be damaged.

SAVE THESE INSTRUCTIONS!

DESCRIPTION

The wiSCAPE® Fixture Module is a bidirectional wireless RF device that allows an individual fixture to be managed, monitored and metered. Universal input voltage allows the module to function on 120-480V circuits at 50/60 Hz. The Fixture Module works with all fixture types including: LED, Induction, MH-HPS-LPS, Incandescent, Halogen and Plasma. The adaptable sink and source 0-10V output is compatible with all dimming drivers. Digital and analog inputs and outputs make sending and receiving signals from additional control devices simple and easy.

wiSCAPE Fixture Modules communicate wirelessly over a robust 2.4GHz OR 900MHz ISM (Industrial, Scientific and Medical) certified meshed radio signal.

The wiSCAPE Fixture Module drastically simplifies control and automation of projects, especially in retrofit environments and challenges the legacy world of wired-systems. wiSCAPE wireless control technology adapts easily to complex automation situations for quick, simple and economical commissioning.

SPECIFICATIONS

CONSTRUCTION

- Black
- UL94V-0 Flame Retardant

MOUNTING

- Optional Mounting Enclosure: NEMA 4:
6.25" (158.75mm) H x 3.125" (79.38mm) W
x 3.375" (85.73mm) D

ELECTRICAL

- Voltage:
 - 120-480VAC; 50/60Hz (+/- 10%)
 - Less than 1 watt consumption at 120V
- Maximum Load Amperage:
 - 110-240VAC: 7 Amps
 - 277-347VAC: 5 Amps
 - 480VAC: 2 Amps
- Power Metering:
 - Amperage, Voltage, Power (+/- 0.5% accuracy)
 - Power Factor, Cumulative Energy,
 - Burn-time and cycles counters
 - C12.20 metering protocol compliance
- Output Status Monitoring: Standard feature
- 0-10V dimming: For all types of 0-10V drivers and ballasts requiring either sourced (up to 20mA or sunk (up to 5mA)

ELECTRICAL (CONTINUED)

- 3 digital inputs: low voltage, 0-30V / 3mA max at 30VDC (e.g. photocell and/or motion sensor and/or low voltage switches)
- 2 analog inputs: 0-30V / 3mA max at 30VDC (e.g. luxmeter)
- 2 digital outputs: sink (max: 100mA total) or source 2.4mA (10K pull-up)
- Aux power supply: 24VDC, 50mA

OPERATION

- Radio Coverage: Up to 1,000 ft. (300m) between modules. Communication range based on clear line of site. Range may vary widely depending on environmental factors.¹
- Manual-ON/Auto-OFF, Auto-ON/Auto-OFF and grace period compliant (complies with N.Y. LL48 and many other energy regulations)

OPERATING ENVIRONMENT

- Relative humidity: 0-99% non-condensing
- Ambient Temperature Range: -40°F to 158°F (-40°C to +70°C)

CERTIFICATIONS

- ANSI/UL 8750, CSA 22.2 No. 250.13-14
- IP66
- UL94V-0 Flame retardant ABS or epoxy molding

CERTIFICATIONS (CONTINUED)

- 2.4GHz Version: U.S. FCC (Digi XBee PRO 2.4GHz) Part 15.247 Class A: MCQ-PS2CTH, Canada IC: 1846A-PS2CTH, Europe CE: ETSI, Australia: C-TICK, Japan: TELEC
- 900MHz Version: U.S. FCC (Digi XBee PRO 900MHz) Part 15.247 Class A: MCQXB900HP

WARRANTY

- 5 year limited
- See [Hubbell Control Solutions Standard Warranty](#) for additional information

Notes:

- 1 Antenna must be mounted vertically up or down.

Rev E

INSTALLATION

1. Turn power off at the service panel.
2. **DO NOT DISCARD THE INCLUDED SERIAL NUMBER LABELS. SEE STEP (4) BELOW.**
3. Mount the Fixture Module in the installation site.
 - a. Internal Fixture Mounting: Use 8x32 (or 10x32) pan head screws to secure the module inside the lighting fixture ballast cavity. *NOTE: The module should be installed within 12" of the external antenna location.* The antenna must be located outside of any metallic enclosure and visible to another relay antenna or control system antenna. Any obstacle (e.g. wall, beam, tree) will reduce signal path and may result in communication loss. *NOTE: ANTENNA MUST BE POSITIONED EITHER VERTICALLY UP OR VERTICALLY DOWN FOR CORRECT OPERATION.* Drill or punch a 5/8" hole in the fixture for the antenna bushing. Install bushing on to fixture using supplied gasket and locking nut. Insert the antenna from the top of the bushing until flush with the base of the bushing on the inside of the fixture. Route the module's antenna cable to the antenna mounting bushing and connect cable to the antenna. Verify that all connections are secure. Do not over-tighten.
 - b. NEMA4 Enclosure External Mounting: Drill or punch a 5/8" hole into the surface (e.g. ceiling tile, wall, fixture pole, junction box) the enclosure will be mounted to. Mount the enclosure using the pipe nipple with the appropriate gasket and locking nut (not included). *NOTE: ANTENNA MUST BE POSITIONED EITHER VERTICALLY UP OR VERTICALLY DOWN FOR CORRECT OPERATION.*
4. Attach module serial/address barcode sticker (included) to site plans at fixture location or in a fixture log book that identifies where the module is installed.
5. Electrically connect the device to the fixture/circuit as shown in the Wiring Diagram below.
6. Serial Number will be needed later during the system setup process.
7. LED Indicators:
 - YELLOW LED blinking every 3 seconds indicates that the relay is powered and functioning normally.
 - RED LED flashing indicates message reception.
 - GREEN LED flashing indicates message transmission by relay.
8. Perform system setup and/or programming activities as applicable in accordance with the wiSCAPE Express or wiSCAPE Enterprise user manuals.

WIRING DIAGRAM

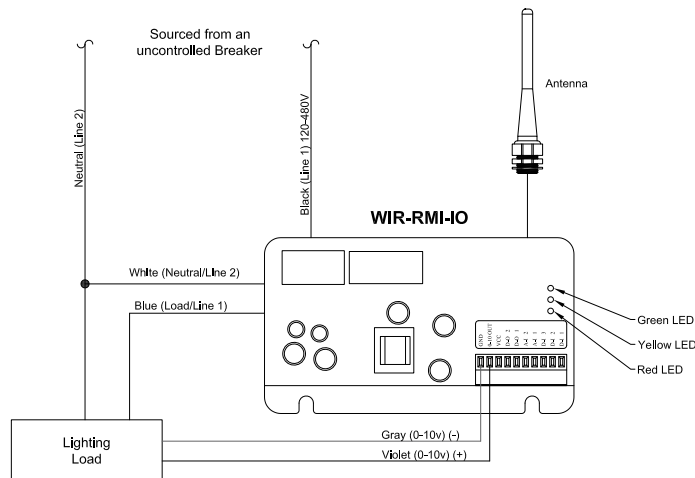

Note:

Do Not install with Power On

Rev E