

INSTALLATION INSTRUCTIONS

FIXTURE TYPE _____

R-D-4400 FIXTURE

P/C **510464-1000**

DATE: 10-28-08

PG. 1 OF 2

DO NOT MODIFY OR ALTER THIS PRODUCT IN ANY WAY, OR INSTALL IN ANY FASHION WHICH IS CONTRARY TO THE INSTRUCTIONS CONTAINED HEREIN. IF YOU HAVE ANY QUESTIONS REGARDING THIS PRODUCT OR THE INSTALLATION OF IT, PLEASE CALL LITECONTROL ENGINEERING AT 781-294-0100.

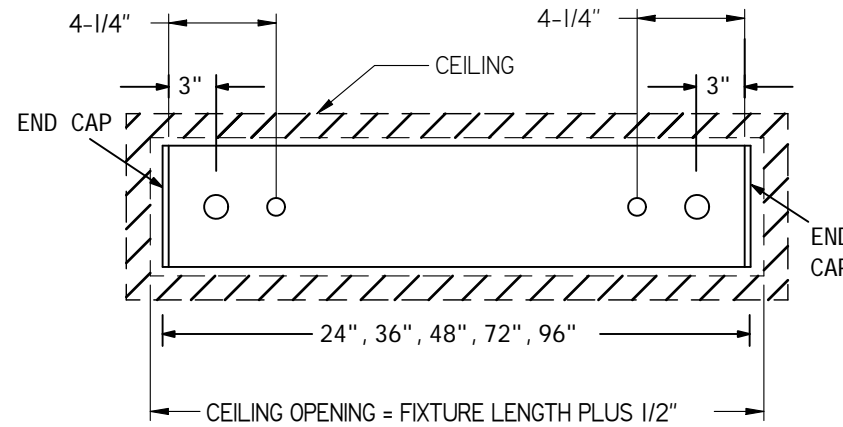
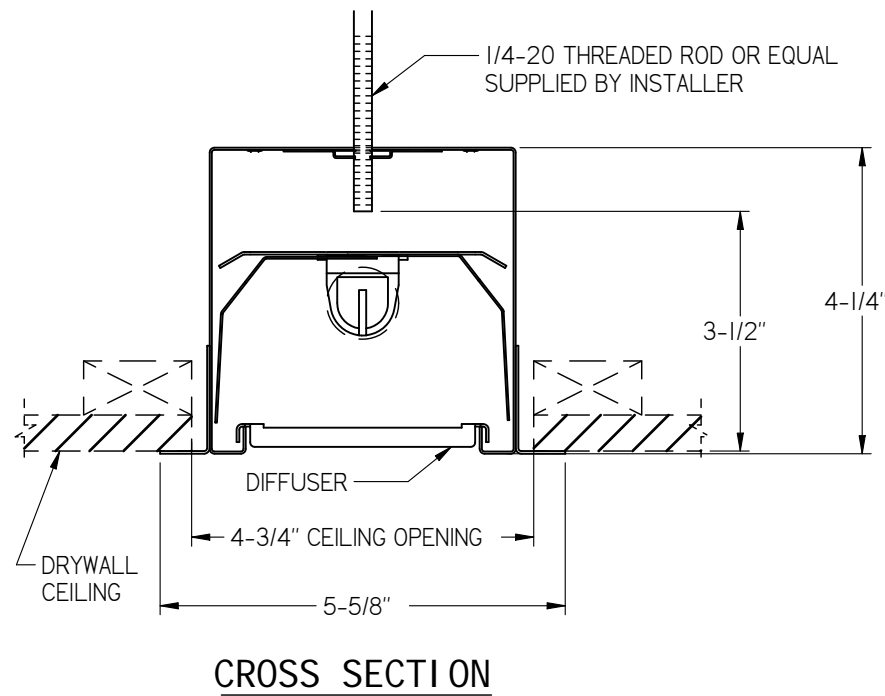

○ = 1/4-20 THREADED ROD LOCATIONS
○ = 7/8" DIA. FEED KO'S

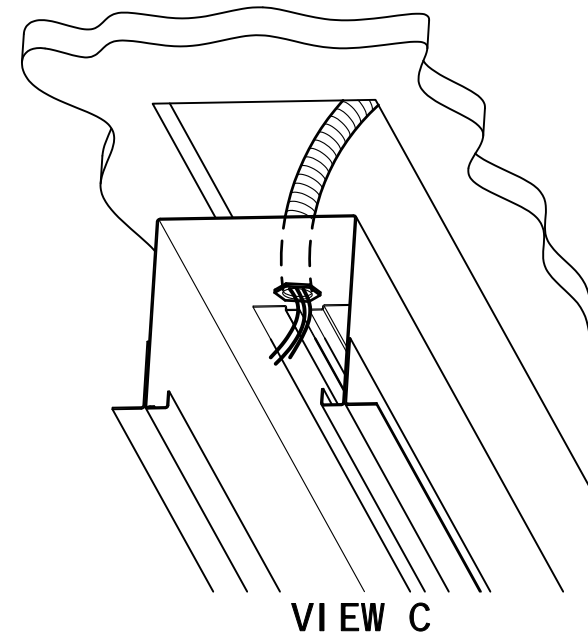
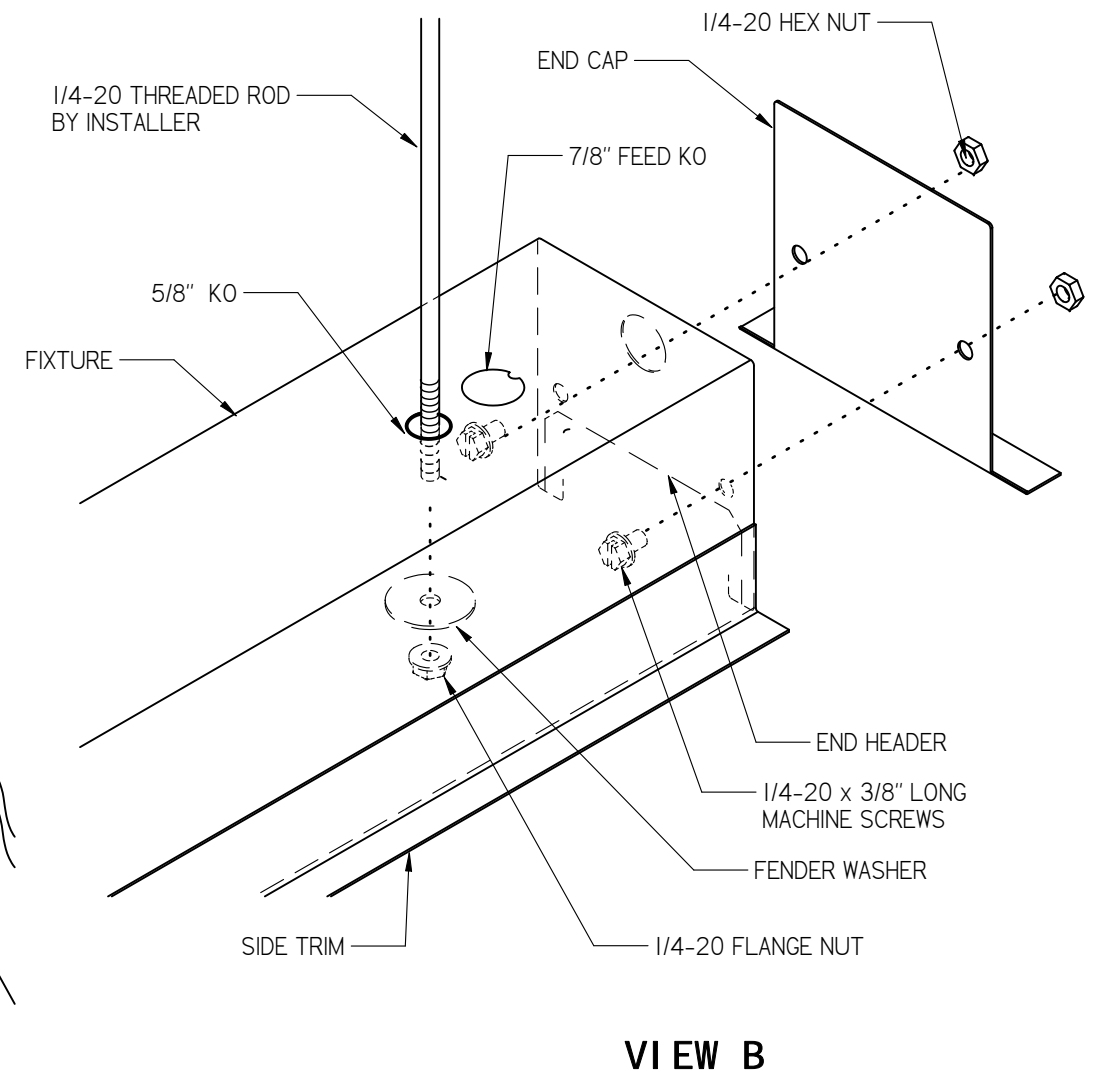
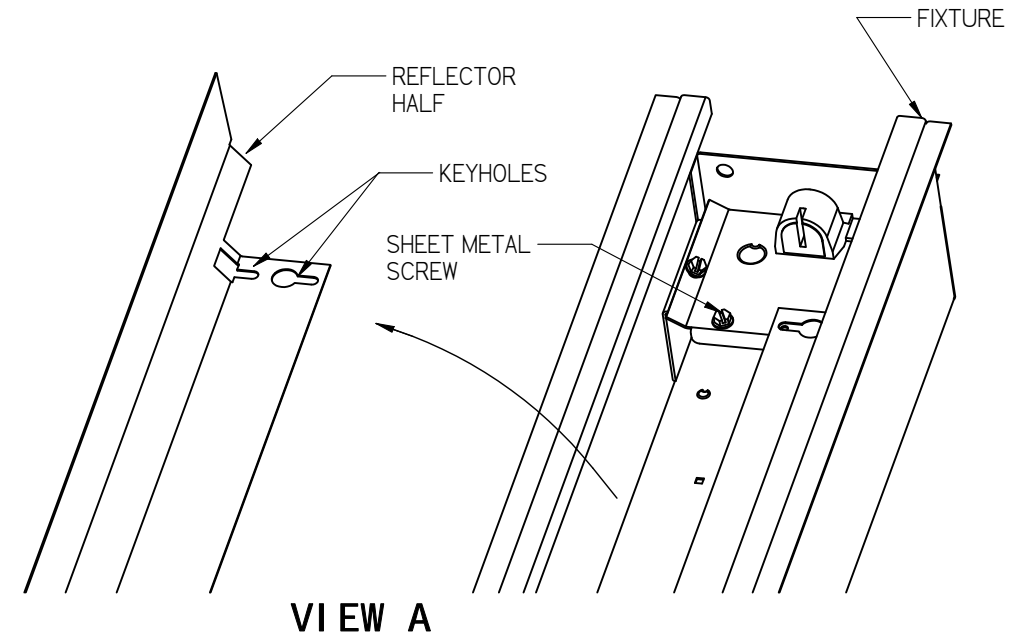

GENERAL NOTES: (READ SHEETS COMPLETELY BEFORE STARTING)

1. Leave protective wrapping material on fixture until fixtures are mounted: This will protect finish from damage.
2. Fixtures are supplied with factory installed branch circuit wiring. Refer to supplemental instruction sheet for making connections.
3. Fixtures are mounted in a drywall ceiling supported with (2) 1/4-20 threaded rods or equal attached to overhead structure supplied by installer. Approximate weight of fixture is 5 lbs per foot of fixture length.

INSTRUCTIONS:

1. Remove Reflector Halves from fixture by loosening (2 or 4) sheet metal screws and shifting them out thru keyholes. See View "A".
2. MOUNTING INDIVIDUAL FIXTURES:
 - A) Remove a 7/8" KO in top of housing at electrical feed location. Remove both 5/8" ko's at ends of housing for threaded rod attachment
 - B) Locate and install (2) 1/4-20 threaded rods in ceiling at locations shown in Plan View. Note threaded rods must end 3-1/2" above finished ceiling as shown in cross section.
 - C) Mount End Caps (shipped separately) to both ends of fixture with (2) 1/4-20 screws and nuts as shown in View "B". Bottom edge of End Caps must be flush with bottom of housing side trims.
 - D) Lift fixture up near ceiling opening and bring electrical feed into fixture wireway. See View "C". Raise fixture up flush to ceiling opening and secure to threaded rods with fender washers and flange nuts (found in polybag): See View "B".
 - E) Make electrical connections in fixture wireway.

GO TO STEP 5 ON PAGE 2

INSTALLATION INSTRUCTIONS

**R-D-4400
FIXTURE**

FIXTURE TYPE _____

P/C **510464-1000**

DATE: 10-28-08

PG. 2 OF 2

DO NOT MODIFY OR ALTER THIS PRODUCT IN ANY WAY, OR INSTALL IN ANY FASHION WHICH IS CONTRARY TO THE INSTRUCTIONS CONTAINED HEREIN.
IF YOU HAVE ANY QUESTIONS REGARDING THIS PRODUCT OR THE INSTALLATION OF IT, PLEASE CALL LITECONTROL ENGINEERING AT 781-294-0100.

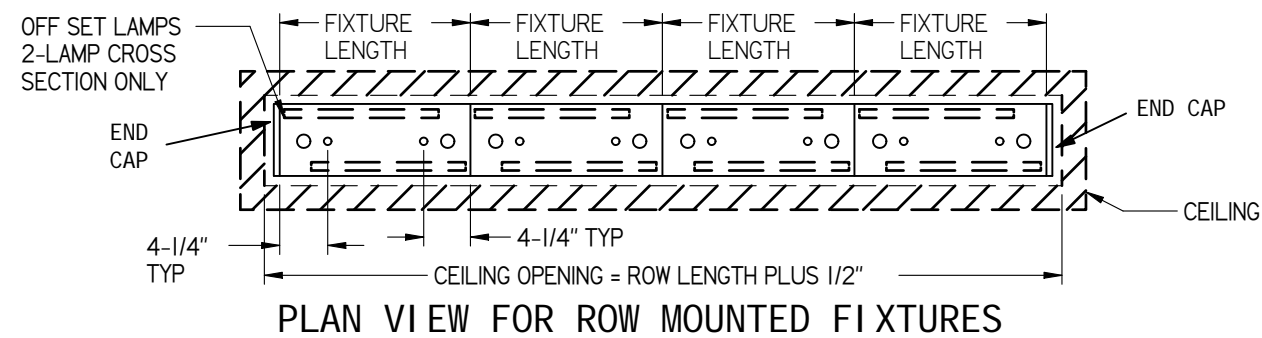

3. MOUNTING ROWS OF FIXTURES:

NOTE: Fixtures are installed in ceiling opening connected to each other at row joint per steps below.
Two lamp cross section fixtures have offset lamp locations, position fixtures in rows as shown above.

- A) Locate and install (2) 1/4-20 threaded rods per fixture in ceiling as shown in Plan View above. Note threaded rods must end 3-1/2" above finished ceiling as shown in cross section on page 1.
 - B) Starting with the first fixture in row, attach an End Cap to one end of fixture per step 2C.
 - C) Remove a 7/8" KO in top of housing for wire feed and the 5/8" KO's at each end of fixture for threaded rods.
 - D) Lift and install fixture into ceiling opening per step 2D
 - E) Remove the 5/8" KO's in the top of the next fixture in the row and install into ceiling: See View "D". Loosely bolt this fixture to the first fixture at row joint with (2) 1/4-20 x 3/8" long machine screws and nuts. Branch circuit wires can be brought thru 7/8" holes in end headers at each row joint.
 - F) Press a Spline (found in polybag) into each bottom rail at row joint for alignment.
 - G) Level each fixture and align seams at row joint before tightening all screws.
 - H) Repeat steps 3C, 3D, & 3E for each additional fixture in row. Install another End Cap onto the last fixture in the row before installing into ceiling.
4. Make all wiring connections in fixture wireways.
 5. Replace all Reflector Halves and remove all wrapping material.
 6. Clean fixture exteriors with a general window cleaner and install lamps (by others). Install lamps by inserting lamp pins into sockets and rotating lamp 90 degrees to lock in place.

7. DIFFUSER INSTALLATION:

Use caution when installing diffusers to prevent lamp damage.

- A) PARABOLIC BAFFLES (PBSS or PBCWM) are shifted into fixture opening and lowered into place by pulling down on baffle until lip sits on bottom rails
- B) LENSES and BLADE BAFFLES are shifted into fixture opening and rest on top of bottom rails. Lenses are installed with the smooth side up.

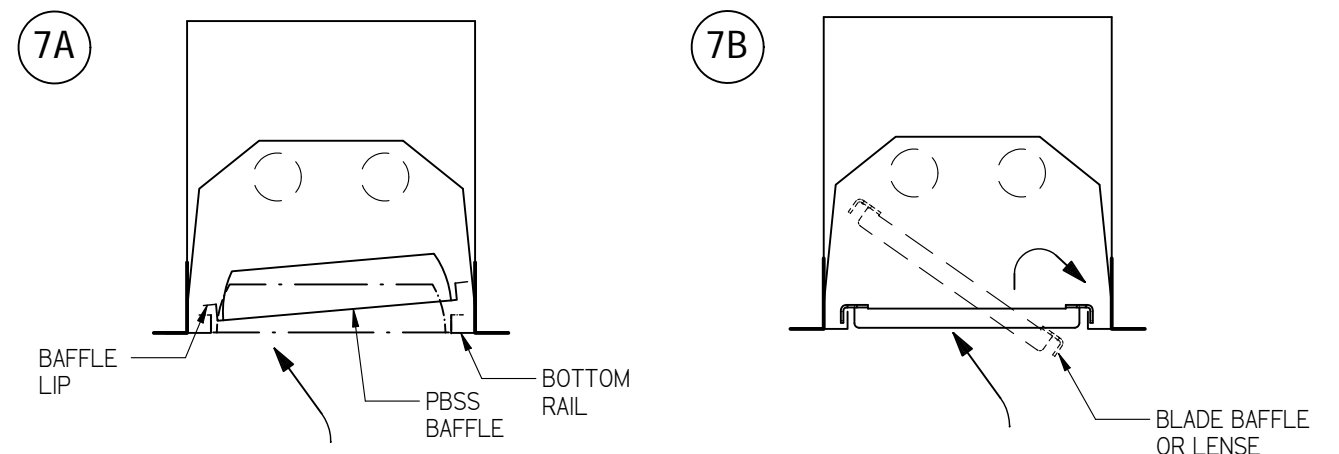
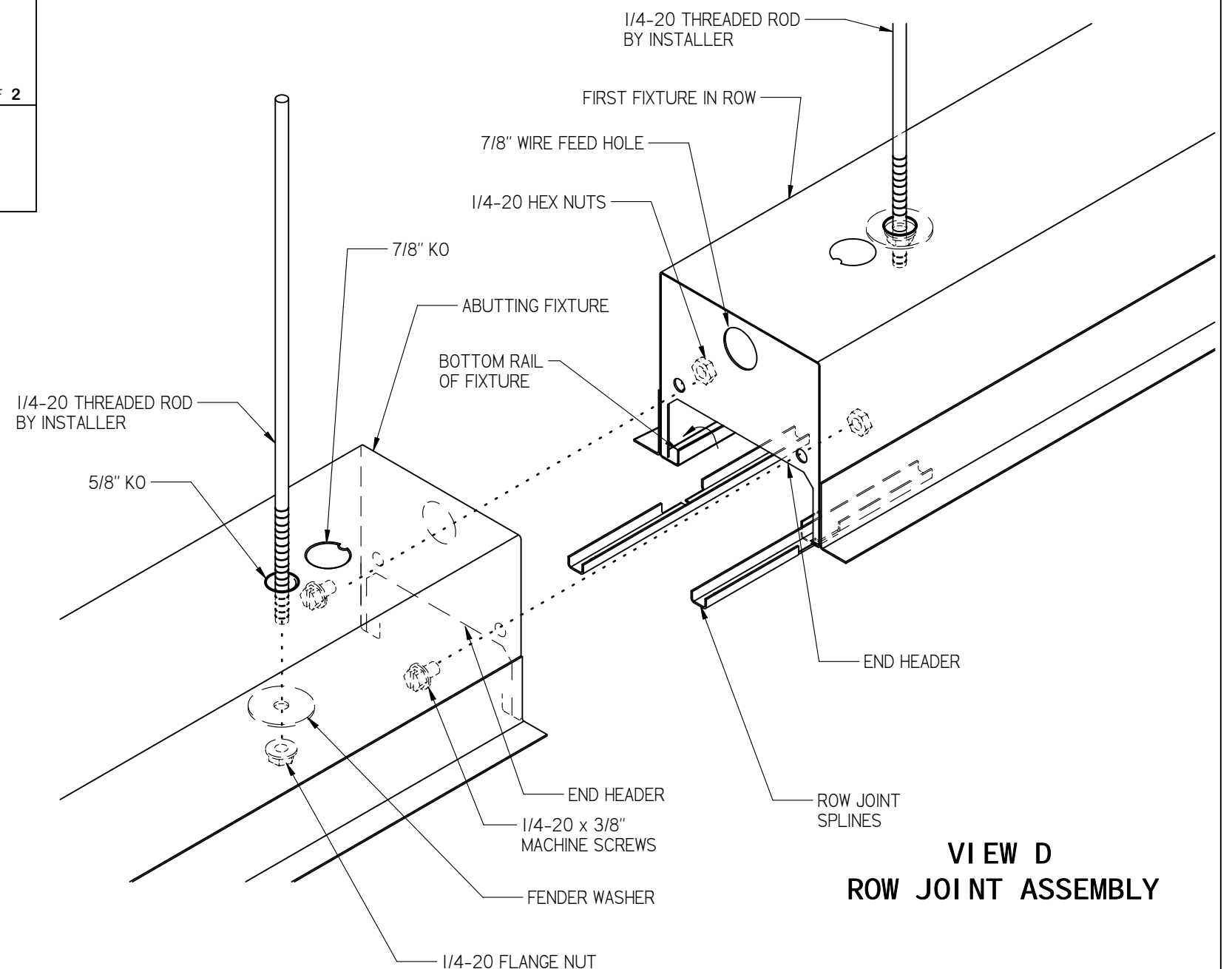

DI FFUSER I NSTALLATI ON