

SIDE VIEW - INDIVIDUALLY MOUNTED

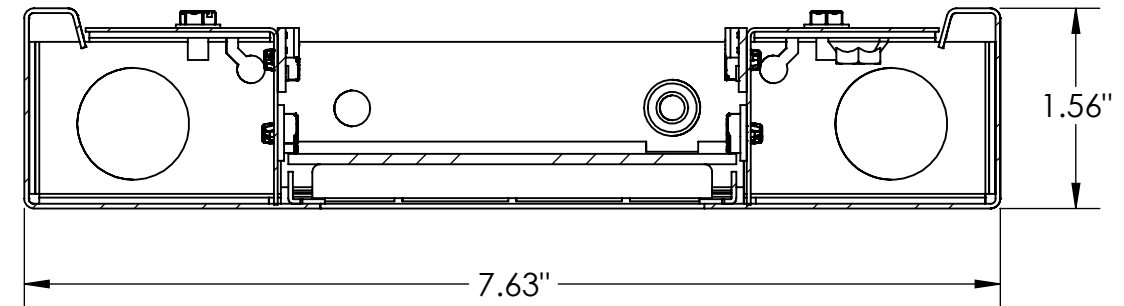

CROSS SECTION VIEW  
P-ID

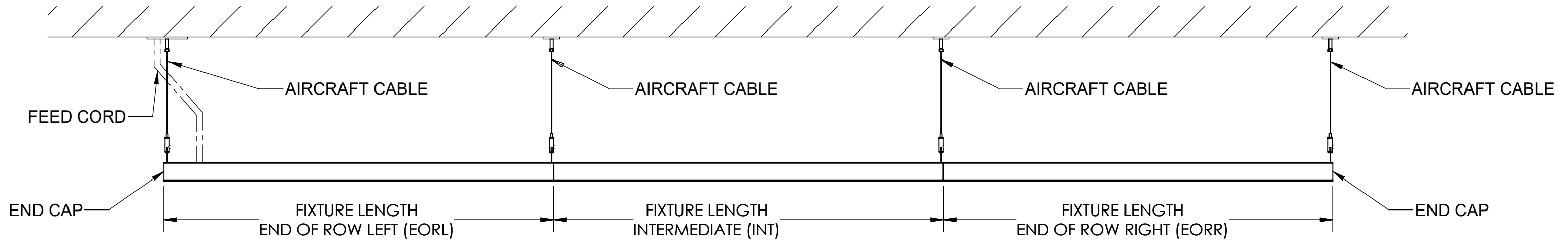

SIDE VIEW - ROW MOUNTED

**GENERAL NOTES: (READ SHEETS COMPLETELY BEFORE STARTING)**

1. LEAVE PROTECTIVE WRAPPING MATERIAL ON FIXTURE(S) UNTIL START OF INSTALLATION TO PROTECT FINISH FROM DAMAGE.
2. FIXTURES ARE PROVIDED WITH FACTORY-INSTALLED BRANCH CIRCUIT WIRING. REFER TO SUPPLEMENTAL INSTRUCTION SHEET 510401 WHEN MAKING CONNECTIONS.
3. APPROXIMATE WEIGHT OF FIXTURE IS 2.50 LBS PER FOOT OF LENGTH.
4. FEED CORDS ARE FACTORY INSTALLED ON INDIVIDUAL FIXTURES. FOR ROW MOUNTED FIXTURES, FEED CORD IS FACTORY INSTALLED AT END OF ROW LEFT (EORL) FIXTURE ONLY. IF ADDITIONAL FEED CORDS ARE REQUIRED FOR THE ROW, THEY WILL BE SUPPLIED BY LITECONTROL BUT FIELD INSTALLED BY CONTRACTOR.

**TOOLS REQUIRED**

- SCREWDRIVER/DRILL
- 11/32" NUT DRIVER

**SUPPLIED BY INSTALLER**

**1** LOCATE SUSPENSION DIMENSIONS ALONG STRAIGHT LINE IN CEILING AS ILLUSTRATED IN SIDE VIEW ON PAGE 1.

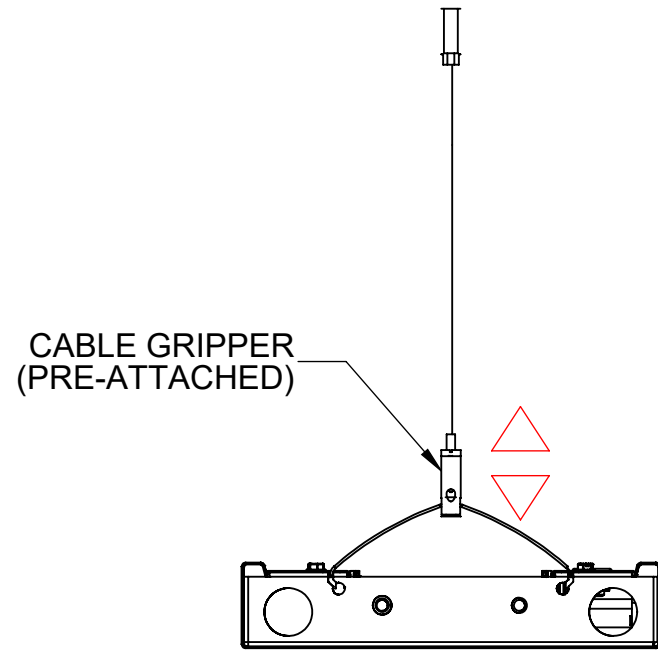

**2**

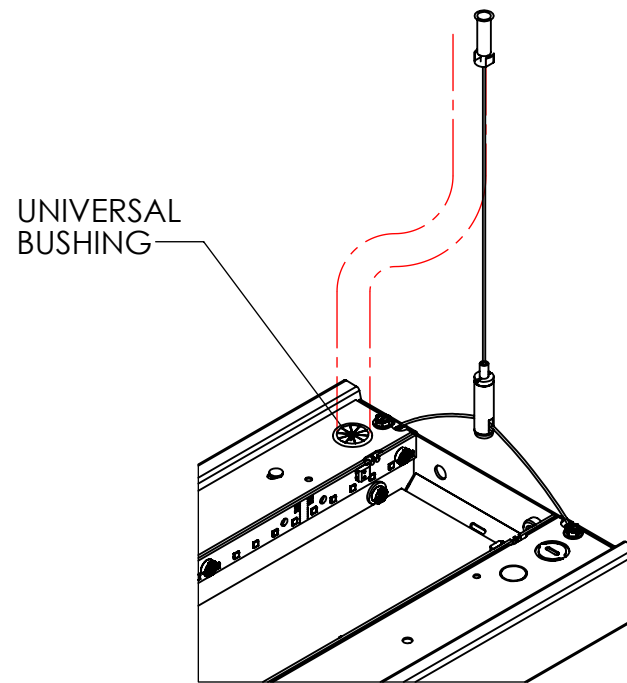

WHEN ADDITIONAL FEEDS ARE REQUIRED: REMOVE LED MODULE. REMOVE ANY OF THE FOUR 5/8" KO'S ON THE LED MODULE ASSEMBLY, INSERT BUSHING AND FEED POWER CORD THROUGH, MAKE WIRING CONNECTIONS. REPLACE LED MODULE ASSEMBLY.

**3**

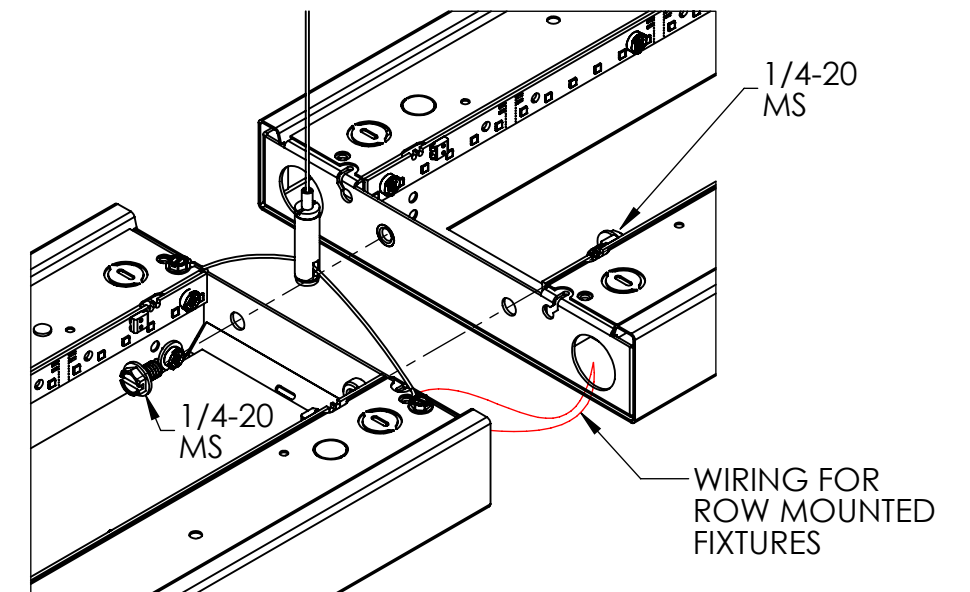

FOR ROW MOUNTED FIXTURES, SECURE FIXTURE JOINTS USING (2) 1/4-20 MACHINE SCREWS. BRANCH CIRCUIT WIRES CAN BE BROUGHT THROUGH FIXTURE JOINTS AS ILLUSTRATED IN STEP 3. REPEAT FOR EACH ADDITIONAL FIXTURE IN ROW.

4 END CAP REMOVAL

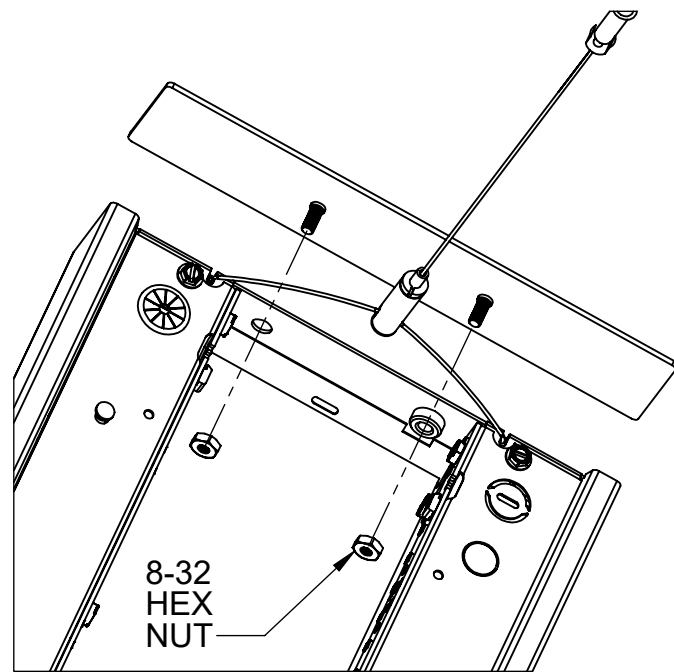

REMOVE END CAPS AT BOTH ENDS OF INDIVIDUAL FIXTURE OR ROW OF FIXTURES BY UNSCREWING (2) 8-32 HEX NUTS.

5 DRIVER REMOVAL

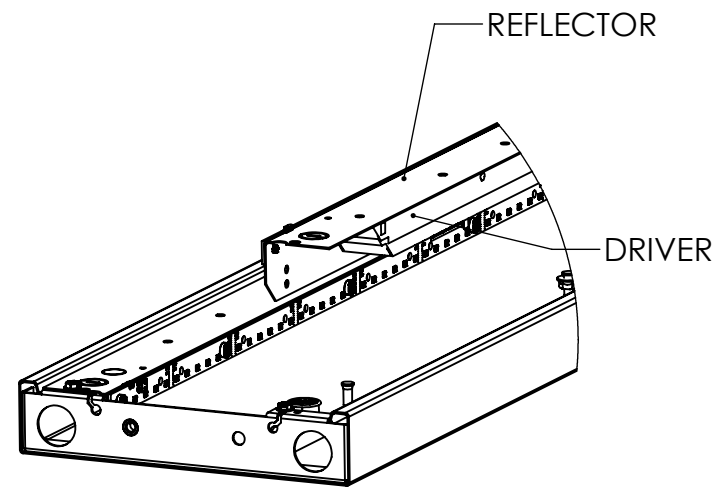

REMOVE REFLECTOR FIXTURE BY UNSCREWING (2) #8 SHEET METAL SCREWS TO ACCESS DRIVER FOR MAINTENANCE

6 DUST COVER REMOVAL (L1 OPTION)

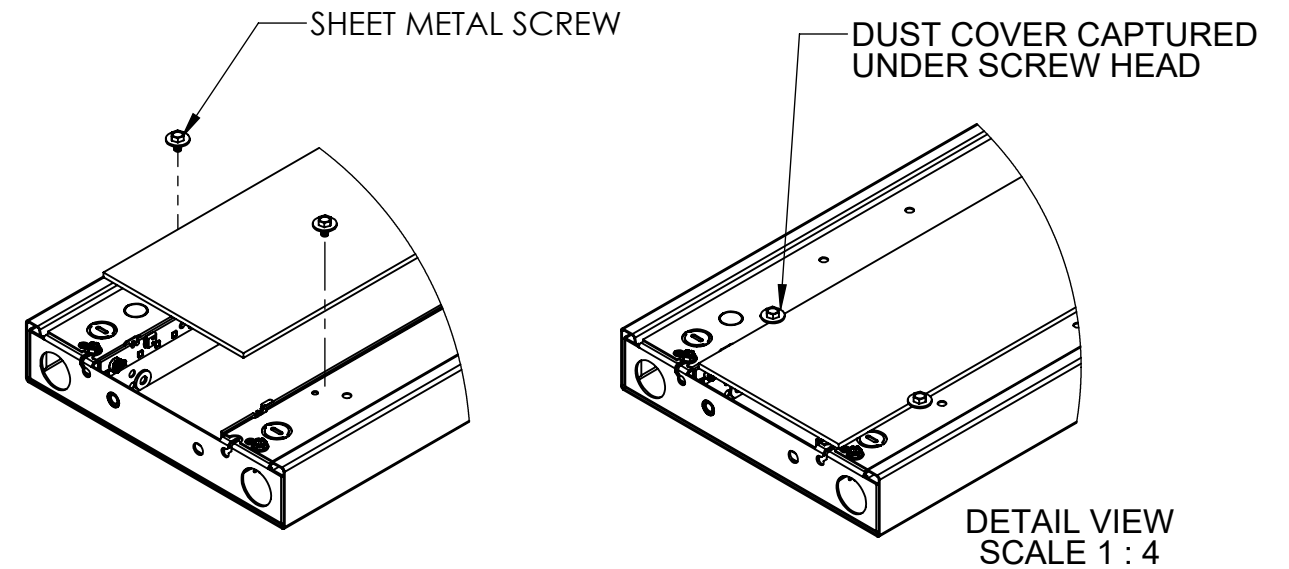

DUST COVER OPTION:  
UNSCREW SHEET METAL SCREWS TO REMOVE DUST COVER FROM LED REFLECTOR MODULE ASSEMBLY. REFER TO ILLUSTRATIONS ABOVE.