

GENERAL NOTES: (READ ALL SHEETS COMPLETELY BEFORE STARTING)

1. LEAVE PROTECTIVE WRAPPING MATERIAL ON FIXTURE(S) UNTIL START OF INSTALLATION.
2. REFER TO VIEWS FOR LOCATIONS OF MOUNTING BRACKETS (SHIPPED SEPARATELY).
3. WALL BRACKETS SHOULD BE MOUNTED PRIOR TO INSTALLING FIXTURES. BRACKETS ARE REQUIRED FOR ALL FIXTURE LENGTHS. USE (2) WALL BRACKETS PER FIXTURE.
4. FIXTURES ARE PROVIDED WITH FACTORY-INSTALLED BRANCH CIRCUIT WIRING. REFER TO SUPPLEMENTAL INSTRUCTION SHEET 510401 WHEN MAKING CONNECTIONS.
5. SAE103-W-I WILL NOT HAVE DOWNLIGHT DIFFUSER OR WINDOW.

TOOLS REQUIRED

- SCREWDRIVER/DRILL
- 11/32" HEX NUT DRIVER

SUPPLIED BY INSTALLER

- ANCHOR SCREWS

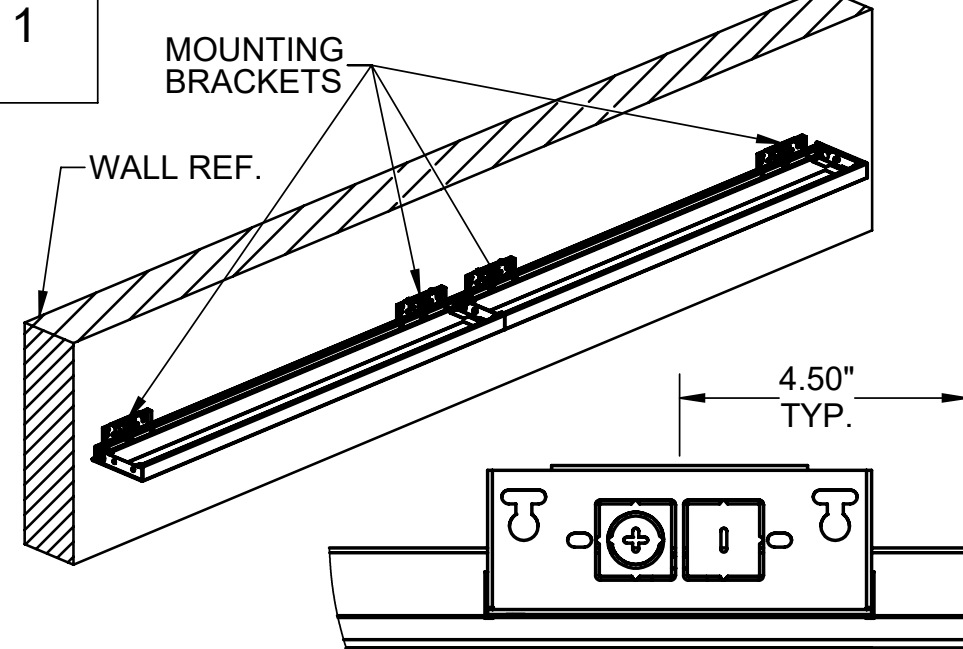

PREPOSITION BRACKETS ON WALL ALONG STRAIGHT LINE AND AT CORRECT DISTANCES FROM EACH OTHER. MARK LOCATIONS OF MOUNTING HOLES.

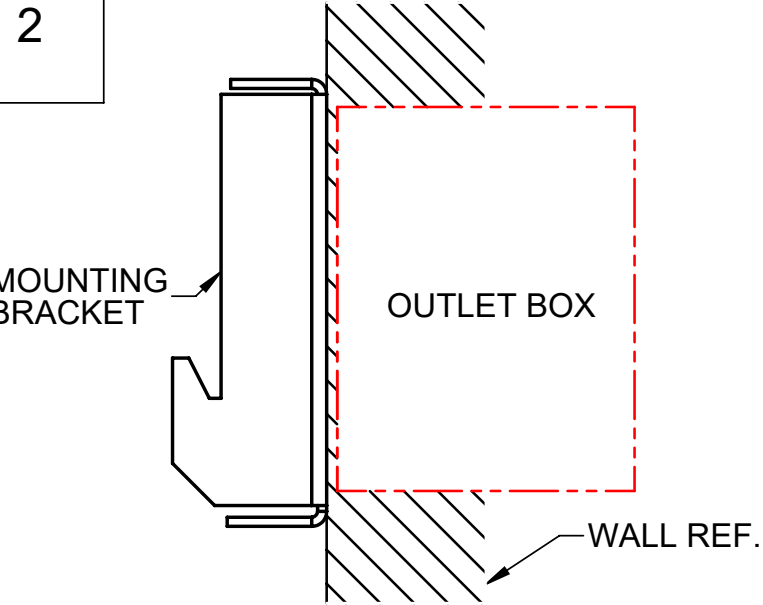

FOR FEED LOCATIONS, ATTACH WALL BRACKET TO OUTLET BOX, USING EITHER A 2" X 4" HANDY BOX OR A 4" OUTLET BOX WITH A PLASTER RING MOUNTED HORIZONTALLY. NOTE OUTLET BOX MUST BE ADEQUATELY ATTACHED TO STRUCTURE FOR SUPPORTING FIXTURE WEIGHT.

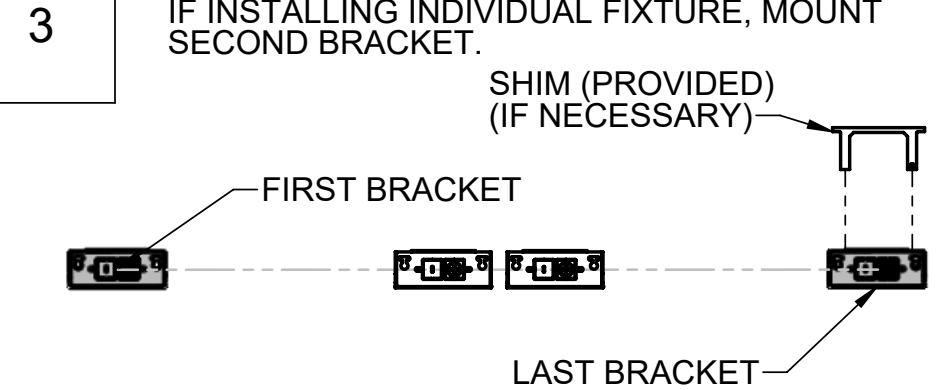

IF INSTALLING INDIVIDUAL FIXTURE, MOUNT SECOND BRACKET.
IF MOUNTING ROW OF FIXTURES, MOUNT THE FIRST AND LAST BRACKETS FIRST, THEN MOUNT ALL OTHER BRACKETS BETWEEN THEM. MAKE SURE THAT ALL BRACKETS ARE ALIGNED.

USE CORRECT ANCHORING TO ENSURE THAT FIXTURE WILL NOT PULL AWAY FROM WALL WHEN ATTACHED. IF REQUIRED, USE SHIMS BETWEEN WALL SURFACE AND BACK OF BRACKETS.

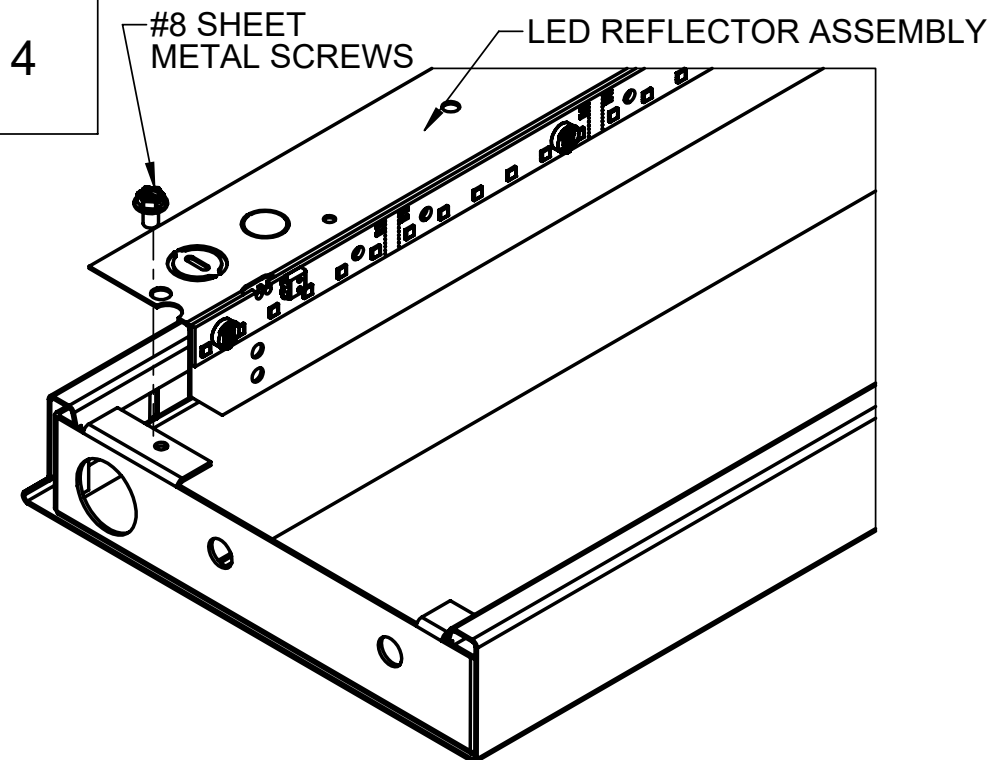

REMOVE LED REFLECTOR ASSEMBLY FROM FIXTURE BY REMOVING #8 SHEET METAL SCREWS.

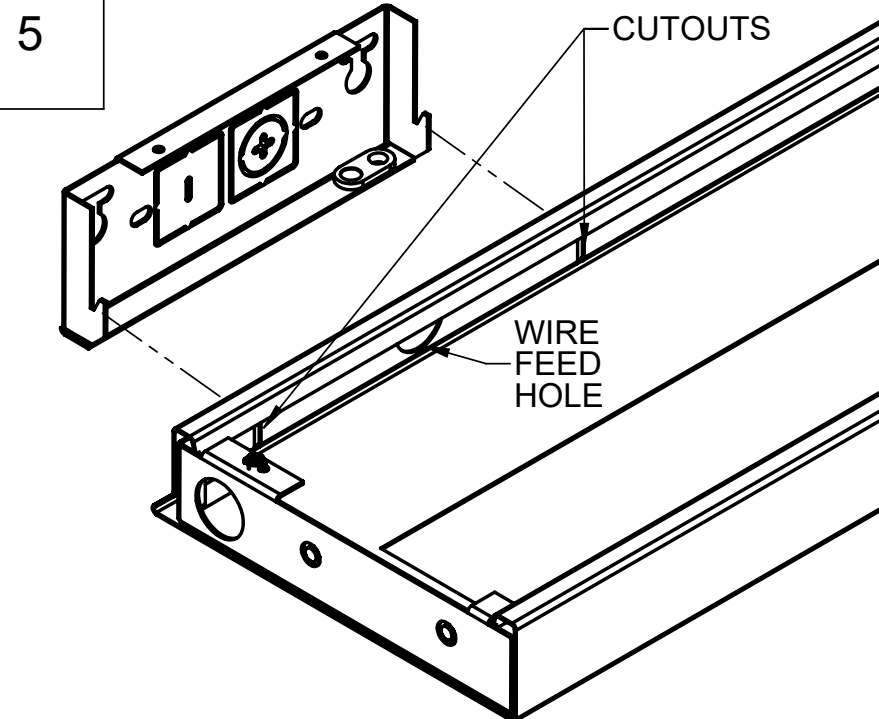

LIFT FIXTURES ONTO WALL BRACKETS THROUGH RECTANGULAR CUTOUTS IN THE HOUSING BACK.

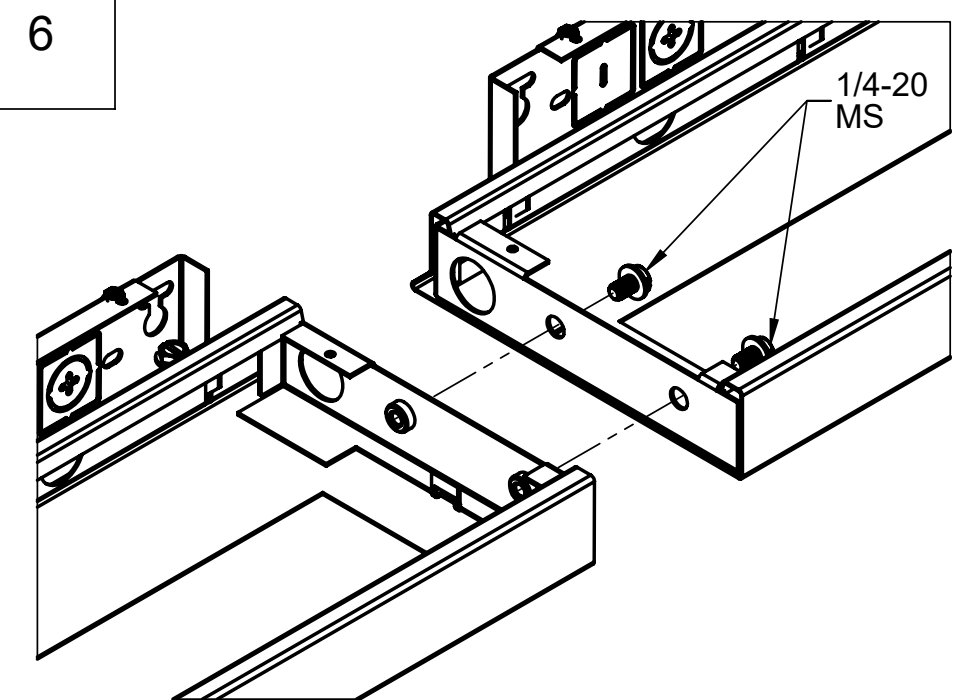

IF INSTALLING ROW OF FIXTURES, BOLT ADJACENT FIXTURES TOGETHER USING (2) 1/4-20 MACHINE SCREWS PROVIDED. REPEAT FOR EACH ADDITIONAL FIXTURE IN ROW.

7

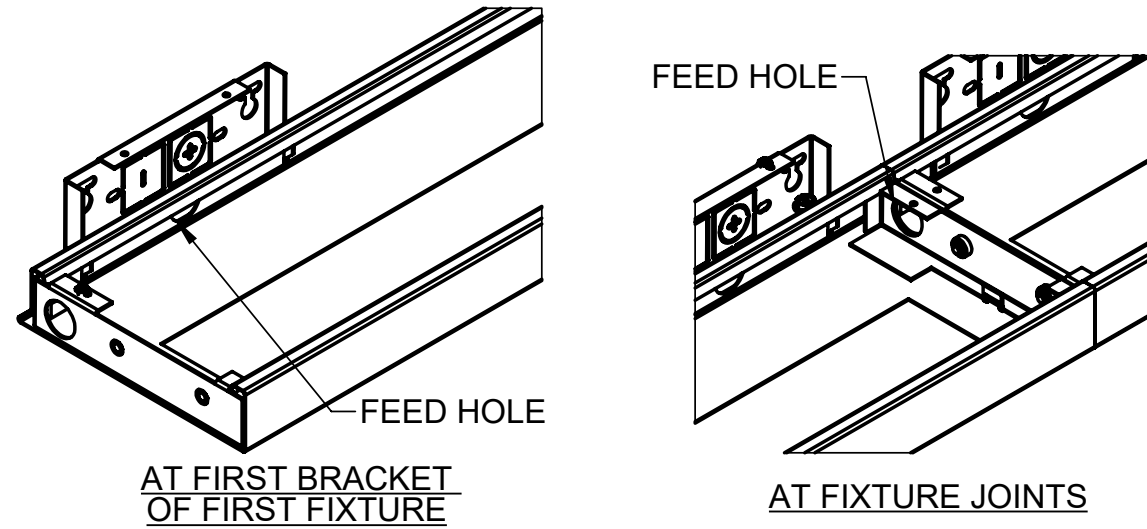

AT FIRST BRACKET OF FIRST FIXTURE

AT FIXTURE JOINTS

MAKE ALL WIRING CONNECTIONS VIA FEED HOLES. FOR ROW, FEED WIRING BETWEEN ADJACENT FIXTURES THROUGH HOLE AT FIXTURE JOINTS. SEE ILLUSTRATIONS.

REATTACH LED REFLECTORS. DO NOT OVERTIGHTEN.

8

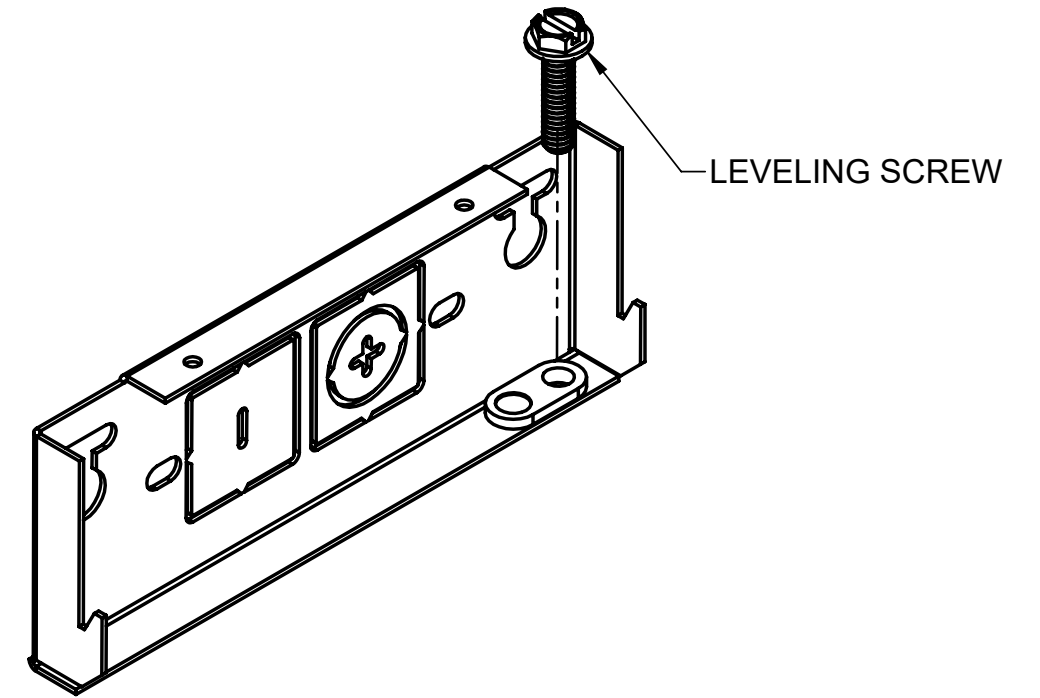

LEVEL THE FIXTURES USING THE 1/4-20 X 1" LONG LEVELING MACHINE SCREWS PROVIDED WITH THE WALL BRACKETS.

9

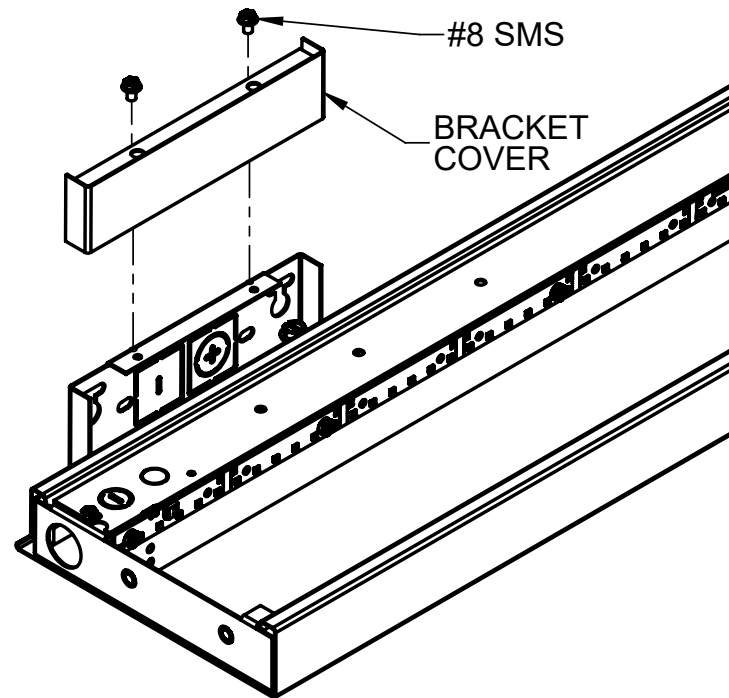

AFTER FIXTURES ARE LEVELED, ATTACH WALL BRACKET COVERS USING #8 SHEET METAL SCREWS PROVIDED. ONCE ATTACHED, THE COVER HOLDS THE FIXTURE ONTO THE WALL BRACKETS.

10

END CAP REMOVAL

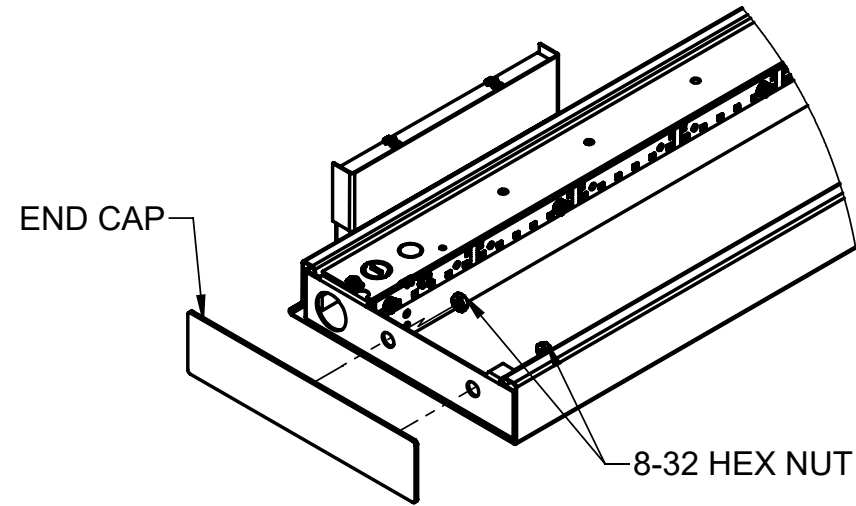

REMOVE END CAPS AT BOTH ENDS OF INDIVIDUAL FIXTURE OR ROW OF FIXTURES BY UNSCREWING (2) 8-32 HEX NUTS.

11

DRIVER REMOVAL

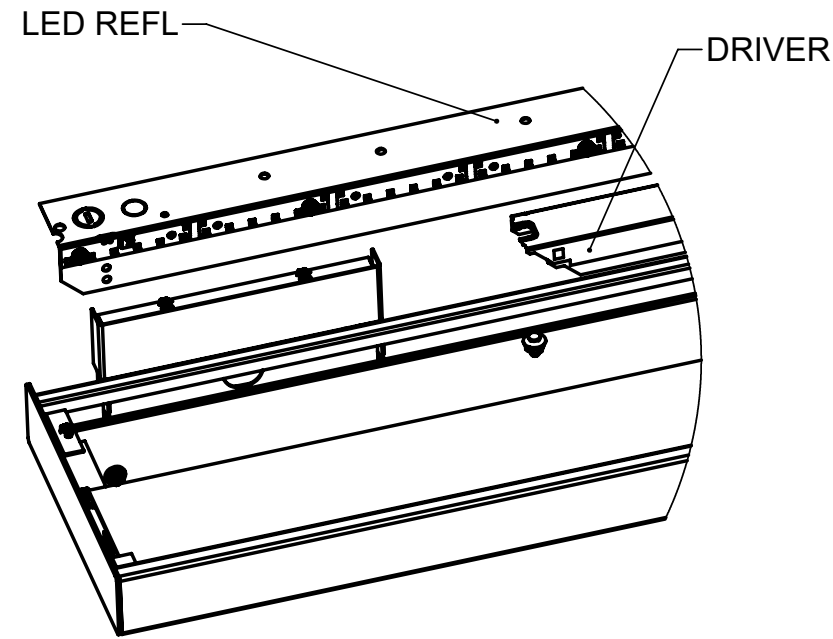

REMOVE REFLECTOR FIXTURE OR ROW OF FIXTURES BY UNSCREWING (2) #8 SHEET METAL SCREWS TO ACCESS DRIVERS FOR MAINTENANCE.

12

DUST COVER REMOVAL (L1 OPTION)

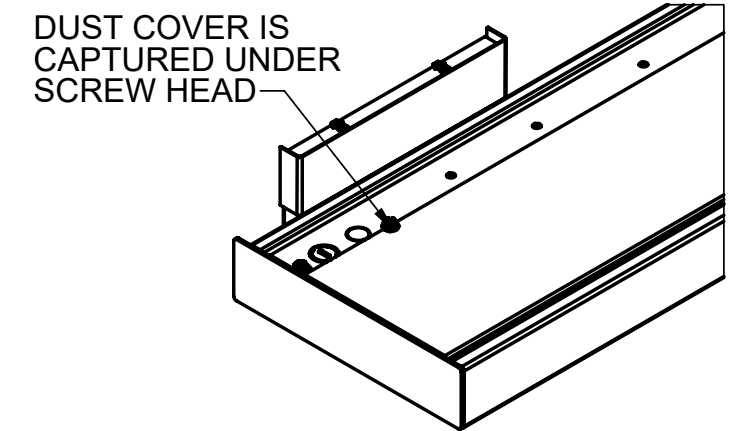

#8 SHEET METAL SCREW

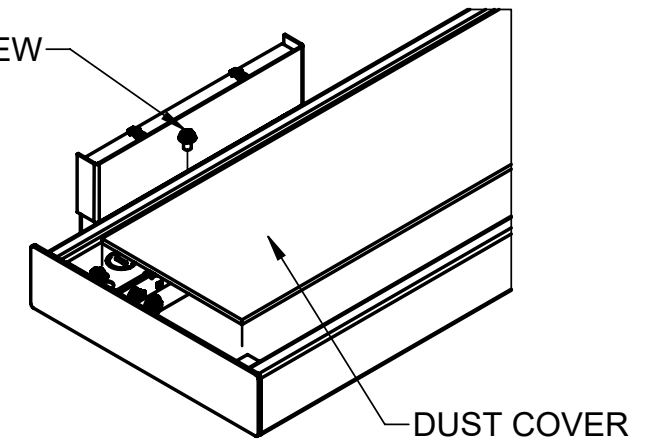

DUST COVER OPTION:
UNSCREW SHEET METAL SCREWS TO REMOVE DUST COVER FROM LED REFLECTOR MODULE ASSEMBLY. REFER TO ILLUSTRATIONS ABOVE.