

Inde-Pendants Family

32L Cylinder

Plaster Trim, Grid and Drywall Ceiling Types

Installation instructions for
32L-C-P-ID
32L-C-P-D

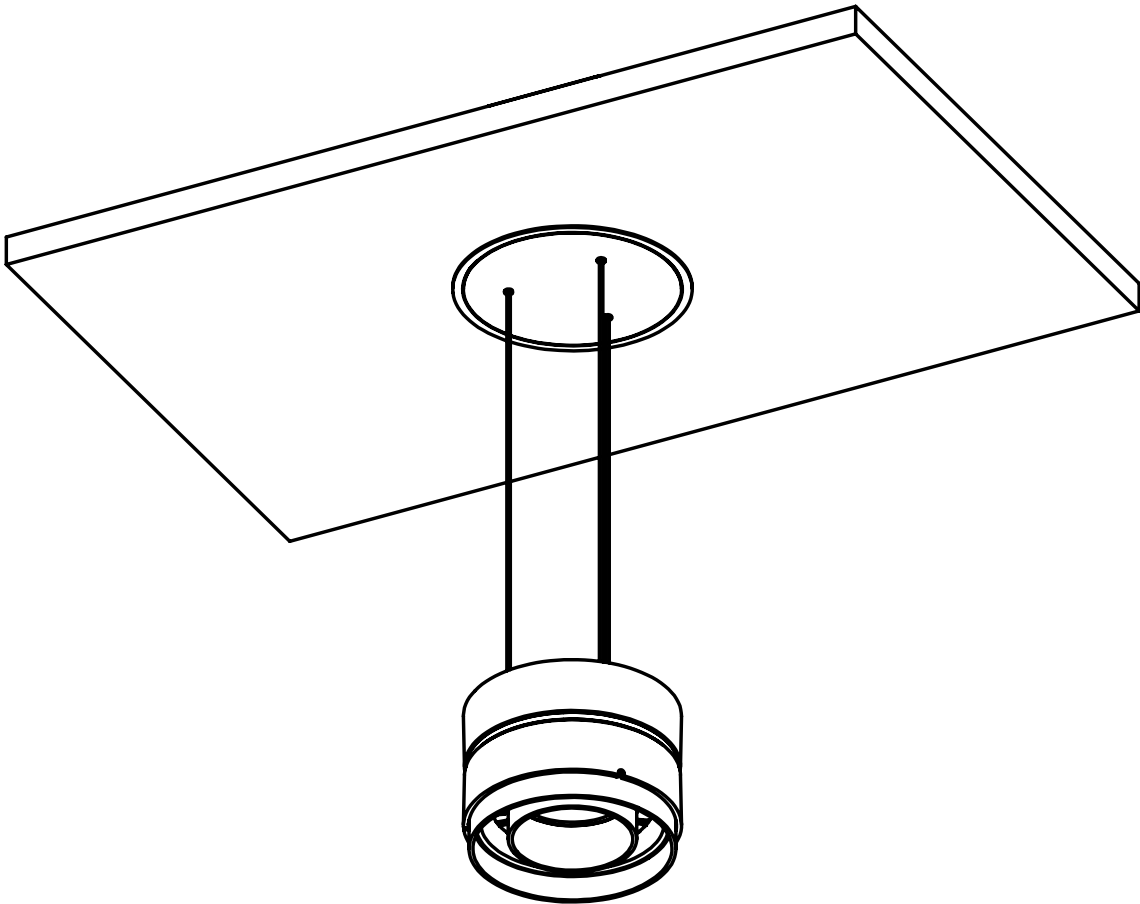

Supplied by Litecontrol

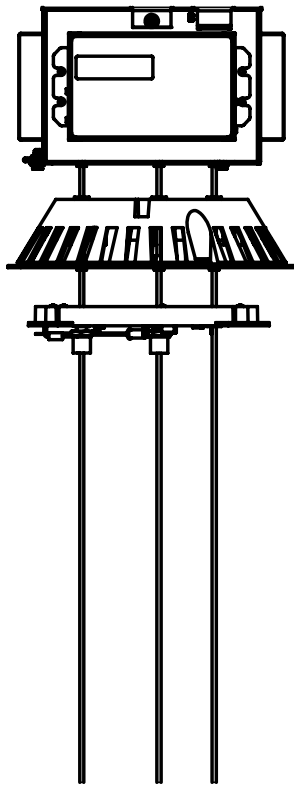

J-box/Cable Kit Assembly
with mounting hardware
SCALE 1 : 5

5
11
5

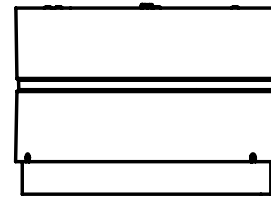

Cylinder
(fixture)
SCALE 1 : 5

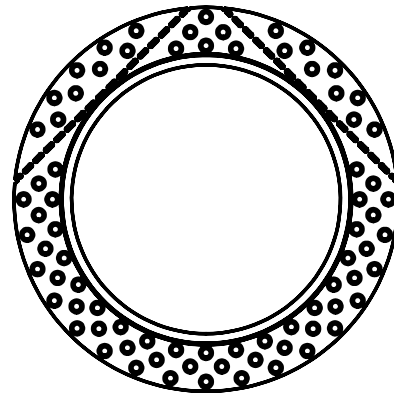

Trim Ring
(Plaster Trim Applications Only)
SCALE 1 : 5

Supplied by Contractor

- 1/4-20 Threaded rod with mounting hardware
- Ceiling tile (T-Grid)
- Romex connectors or alternative hardware for 3/4" knockouts
- Feed cord
- Wire nuts
- Joint Compound, drywall screws and paint to match ceiling (Plaster Trim applications only)

Tools Required

- Wire cutters/strippers
- Tape measure
- Marker
- Felco-type cable cutters
- 1/4" Socket with wrench or flat-head screwdriver
- Level
- Joint knife and paint roller (Plaster Trim applications only)

Ceiling Cut Stencil (not for use with Trim Ring)



To Use Stencil:

1. If using a square tile, draw two lines on the back of the tile from corner to corner so that they intersect at the exact center of the tile to make an "X"
2. Using a pen, screwdriver, etc. punch a small hole through the tile in the center of the "X"
3. Using a pen, screwdriver, etc. punch a small hole through the black dot in the center of the stencil
4. Flip the tile over so that the front face (that will be visible after installation) is face-up
5. Lay the stencil perfectly flat on the tile so that the hole in the stencil is perfectly centered over the hole that was punched in the tile in Step 2 and secure the stencil in place with tape
6. Using a jig-saw, cut the hole in the tile by tracing the stencil **on the black line**
7. Discard stencil after one use

Ceiling Cut Stencil (for use with Trim Ring)



PLASTER CEILINGS

To Use Stencil:

1. If using a square tile, draw two lines on the back of the tile from corner to corner so that they intersect at the exact center of the tile to make an "X"
2. Using a pen, screwdriver, etc. punch a small hole through the tile in the center of the "X"
3. Using a pen, screwdriver, etc. punch a small hole through the black dot in the center of the stencil
4. Flip the tile over so that the front face (that will be visible after installation) is face-up
5. Lay the stencil perfectly flat on the tile so that the hole in the stencil is perfectly centered over the hole that was punched in the tile in Step 2 and secure the stencil in place with tape
6. Using a jig-saw, cut the hole in the tile by tracing the stencil on the black line
7. Discard stencil after one use

1

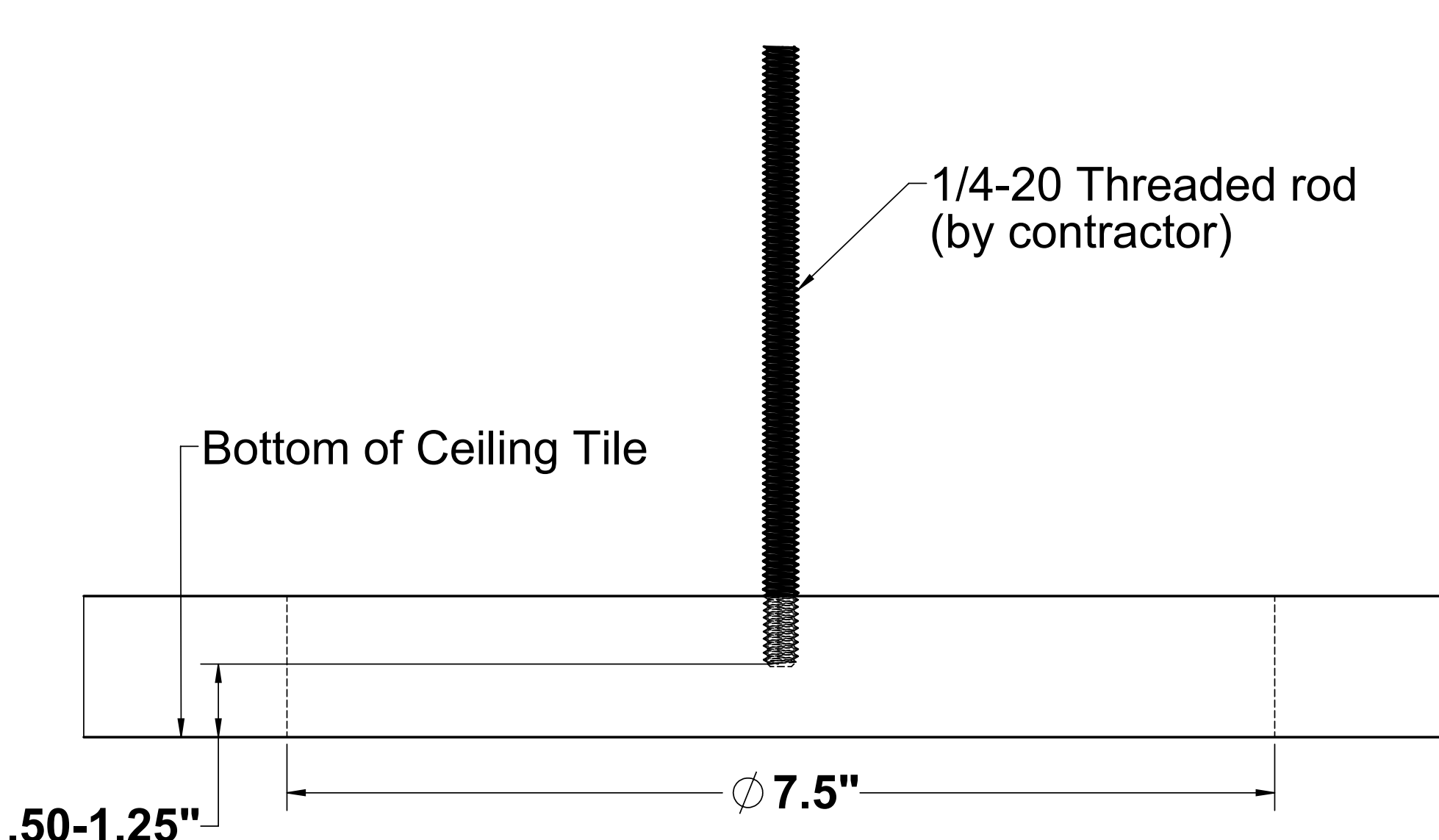
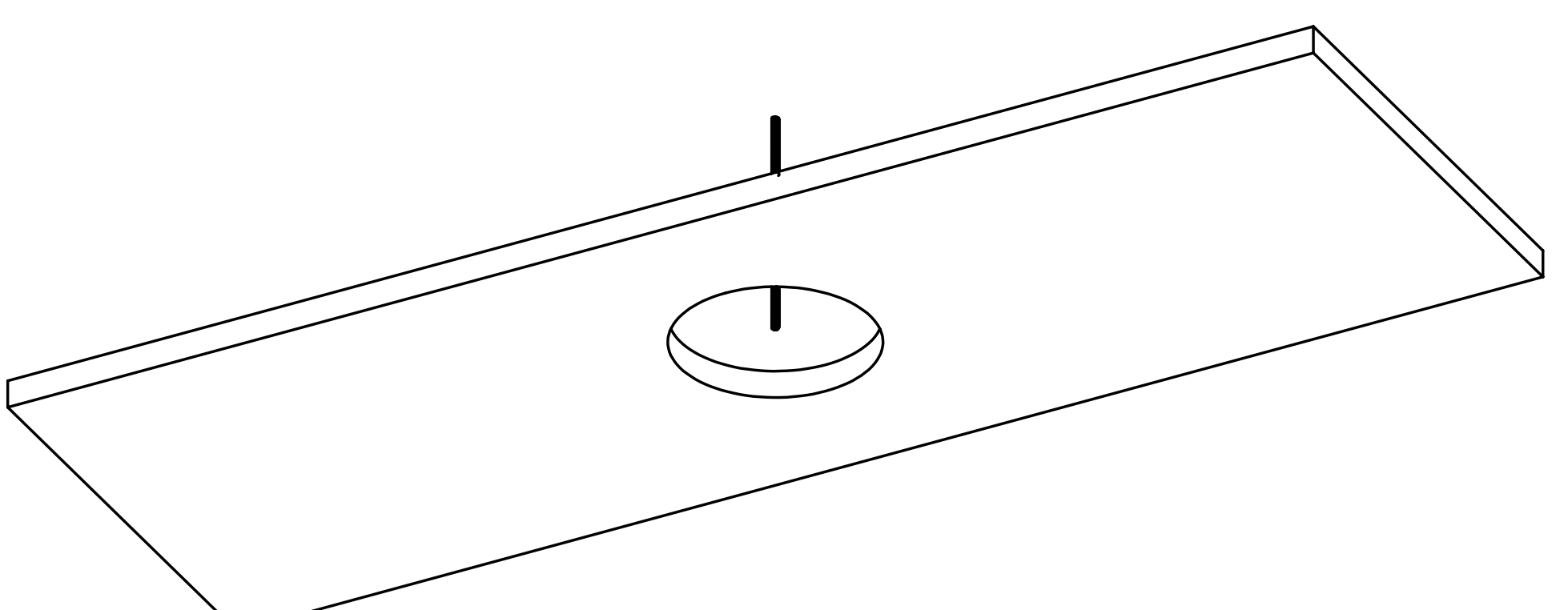

IF NOT USING TRIM RING, CONTINUE TO STEP 1 ON PAGE 6.

- Using stencil on page 4, cut a 7.5" diameter hole in the ceiling (ceiling thickness cannot exceed 3")
- Suspend a 1/4-20 threaded rod per code at the support location so that it ends .5" to 1.25" above the visible ceiling face (bottom of ceiling tile), centered above the hole.

2

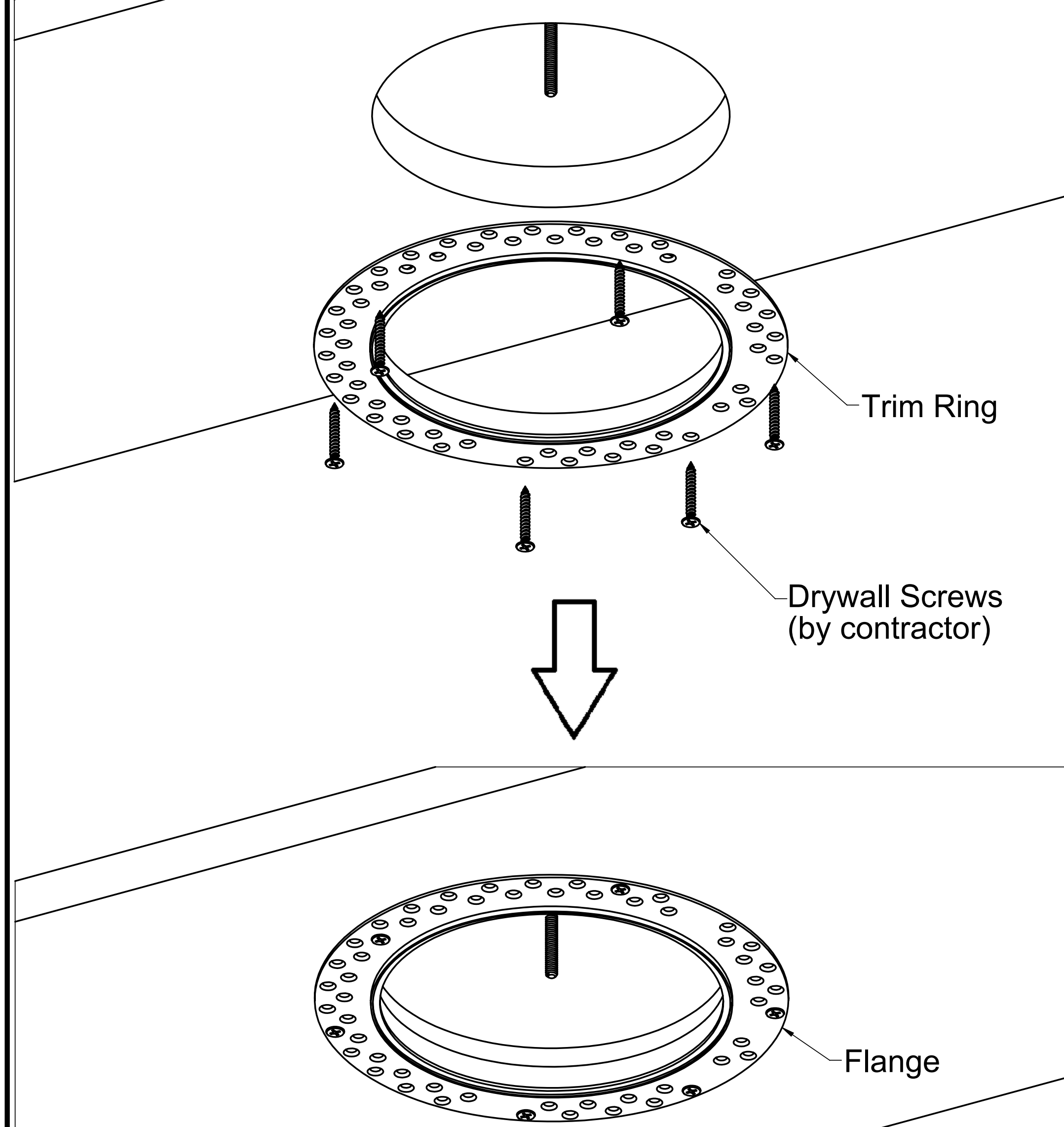

- Install **Trim Ring** in ceiling hole as shown.
- Secure firmly against ceiling with **drywall screws** provided by contractor (at least 6 recommended)

3

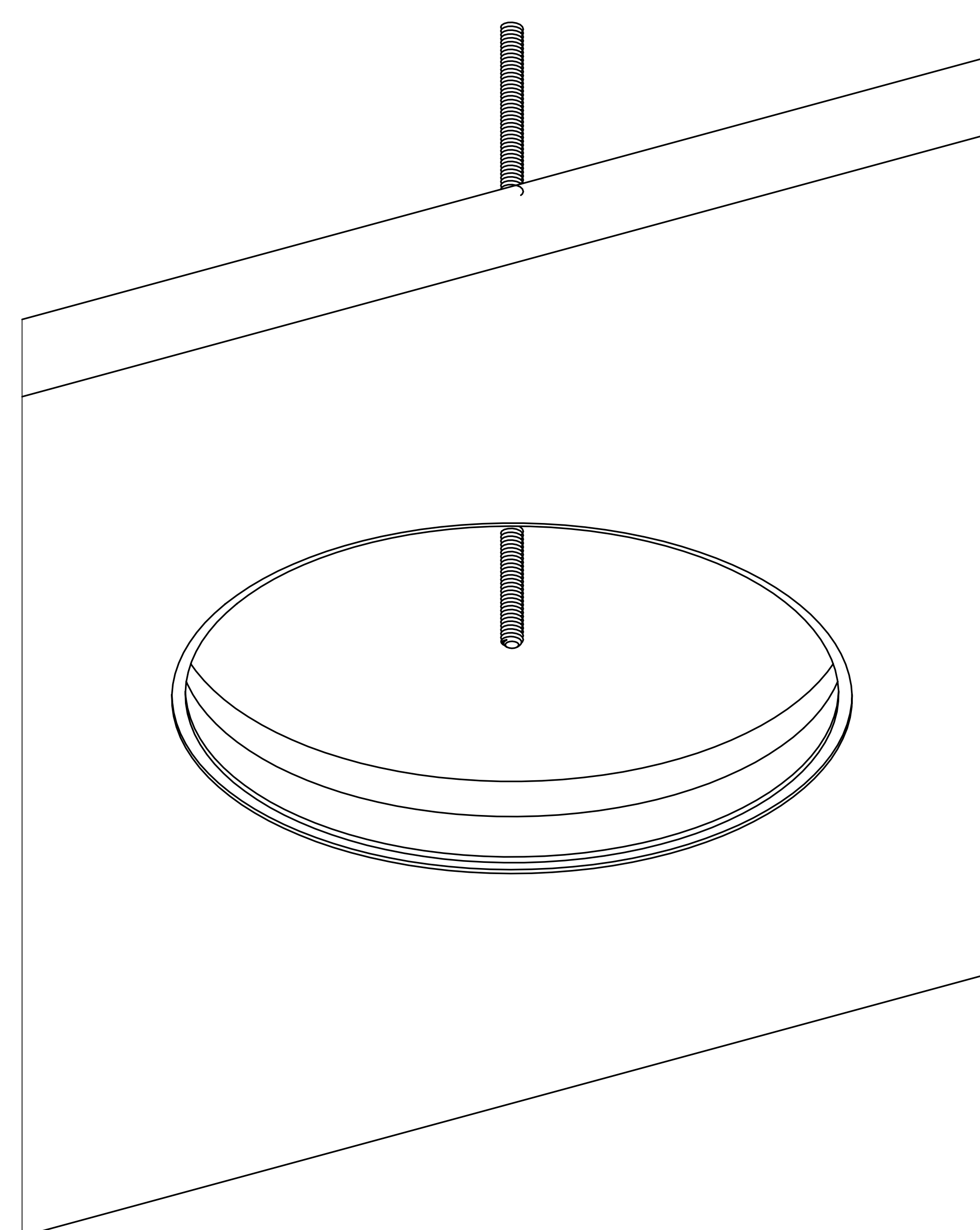

- Plaster over the **Flange** of the **Trim Ring** and the **Drywall Screws** until they are no longer visible and the ceiling appears to be completely smooth (2-3 coats recommended).
- Sand down any excess plaster
- Paint over newly-plastered area of ceiling so that the plastered area blends in with the ceiling.
- Continue to **Step 2 on page 6.**

J-box Installation

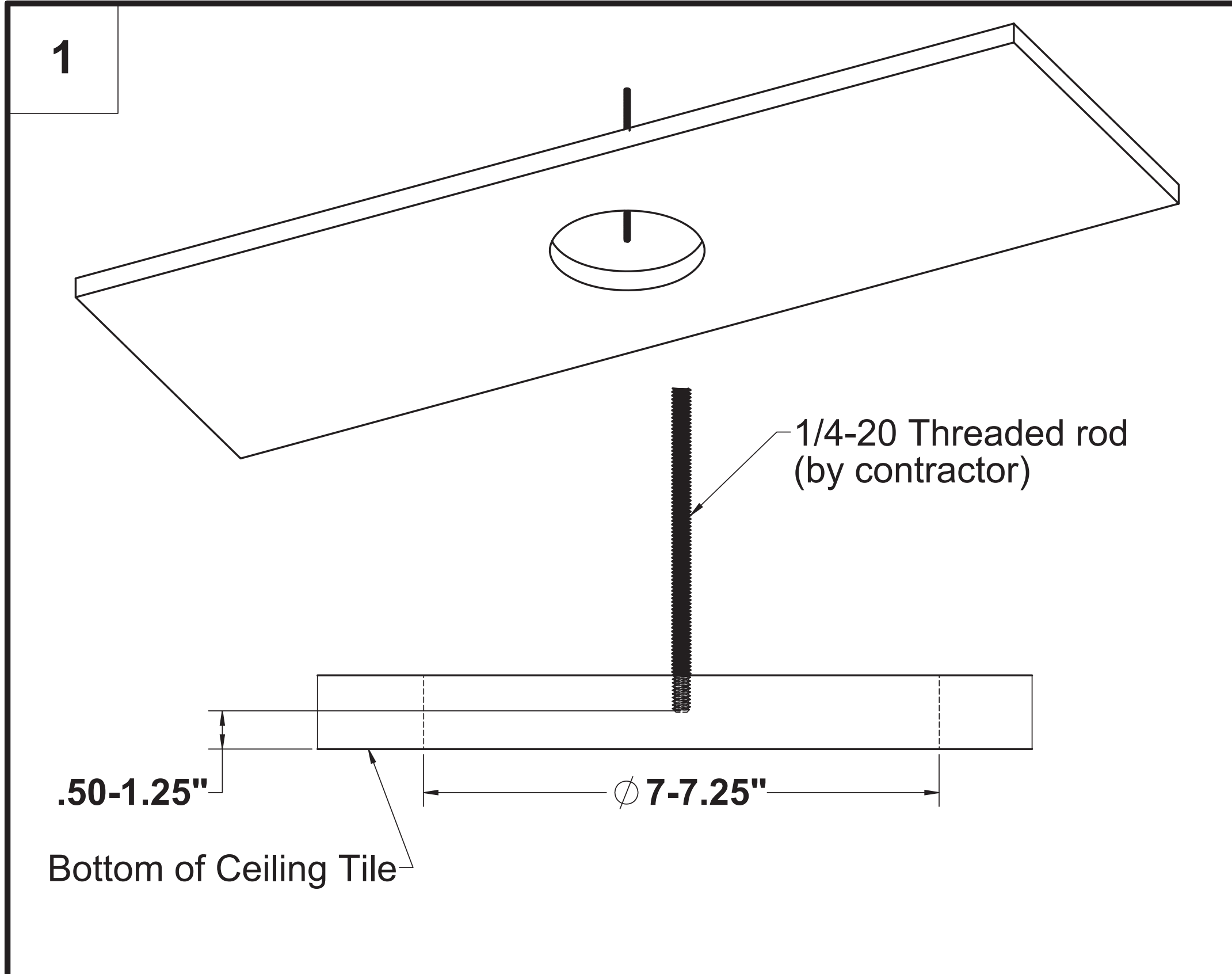

1. Using stencil on page 3, cut a 7" diameter hole in the ceiling tile (ceiling thickness cannot exceed 3")
2. Suspend a 1/4-20 threaded rod per code at the support location so that it ends .5" to 1.25" above the visible ceiling face (bottom of ceiling tile), centered above the hole.

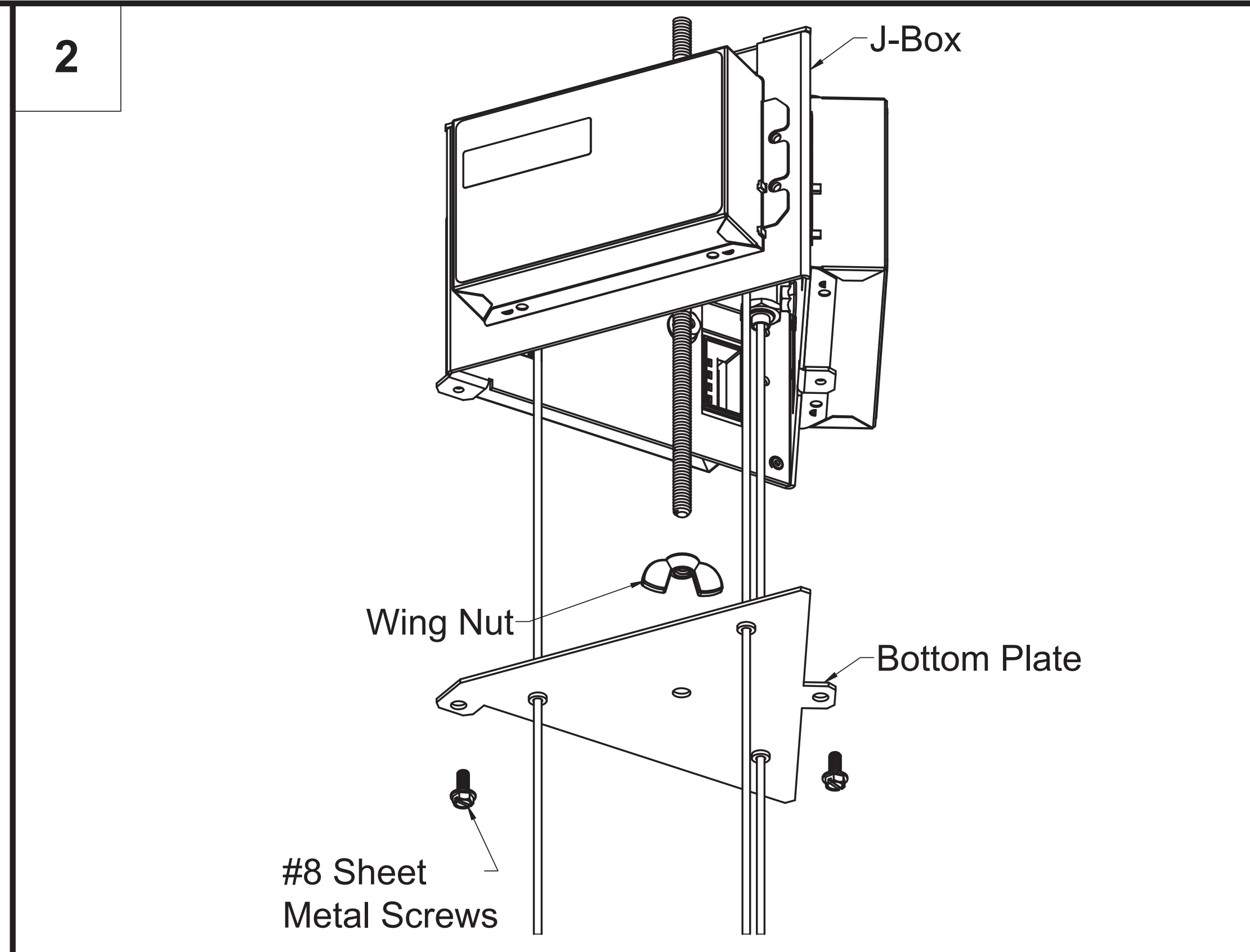

1. Remove the **bottom plate** of the J-box
2. Remove knockouts from **J-box top** as needed
3. Lift the **J-box** up while sliding the threaded rod through the center hole in the top of the J-box so that there is about 1.72" distance between the bottom of the J-box and the bottom of the ceiling tile (see next step)
4. Secure the J-box in place with a **1/4-20 wing nut**
5. Install electrical feed cord and make all wiring connections (see attached wiring diagrams). **Power supply circuit enters the J-box through the 7/8" knockouts on the J-box top.**
6. Re-install the bottom plate using the two **#8 screws**.

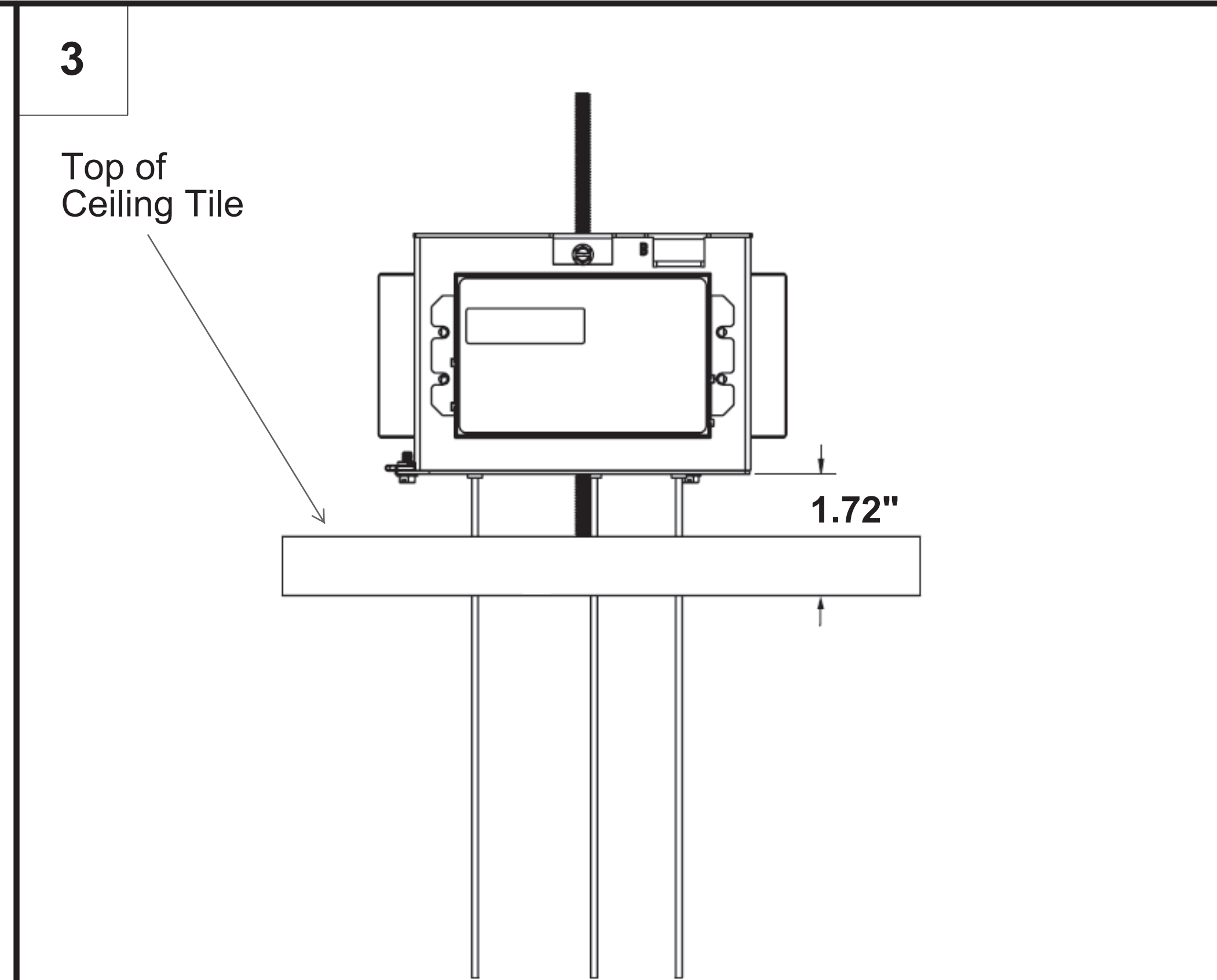

1. Thread the **wing nut** up so that the J-box is up higher on the threaded rod, so that there is now 1.72" distance between the J-box bottom and the bottom of the ceiling tile.

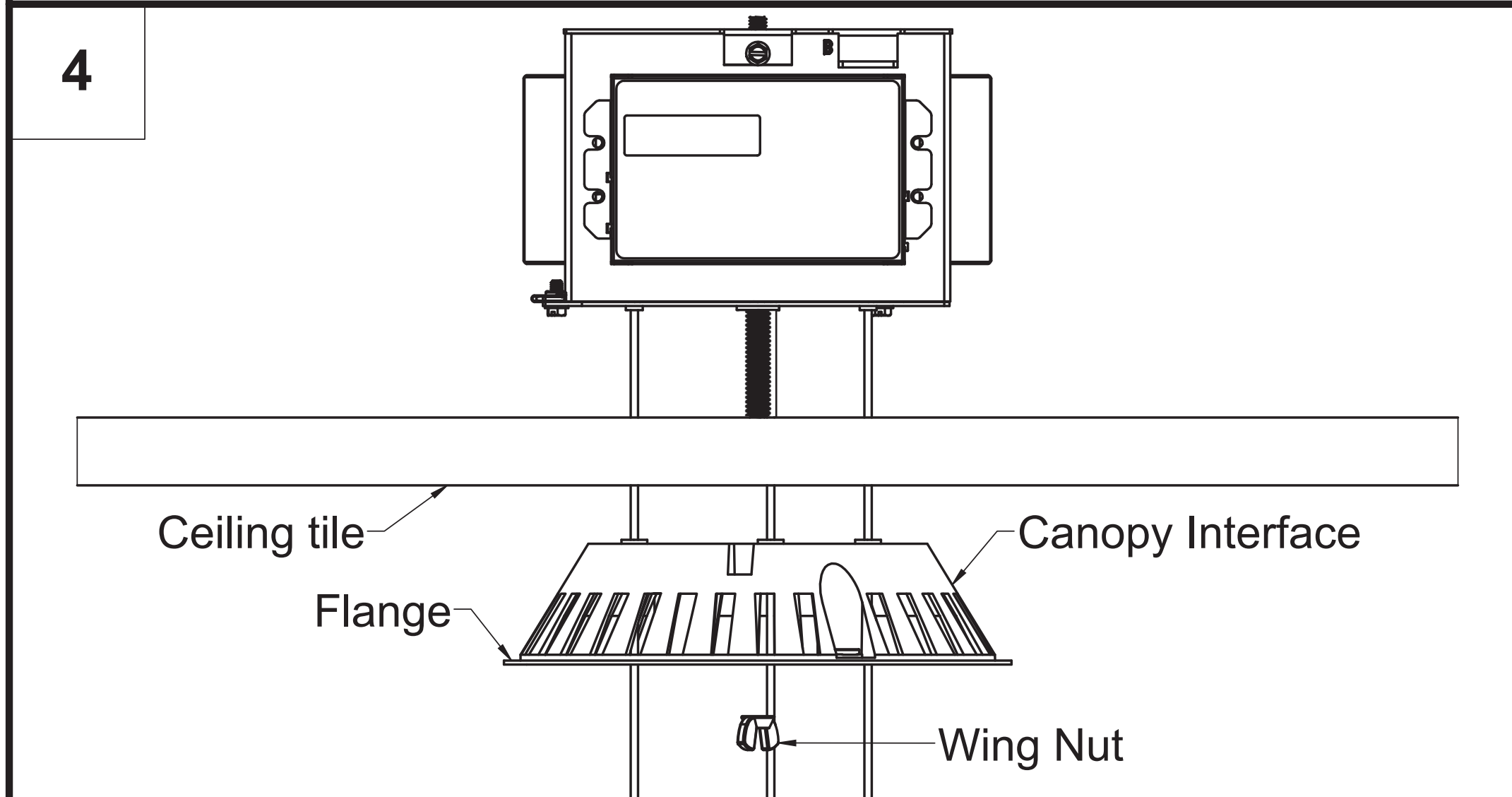

1. Lift the **canopy interface** up and slide the threaded rod through the center hole in the top
 2. Secure with a **wing nut** until the **flange** of the canopy interface is flush with the bottom of the ceiling tile.
- Note: Do not over-tighten the wing nut.**

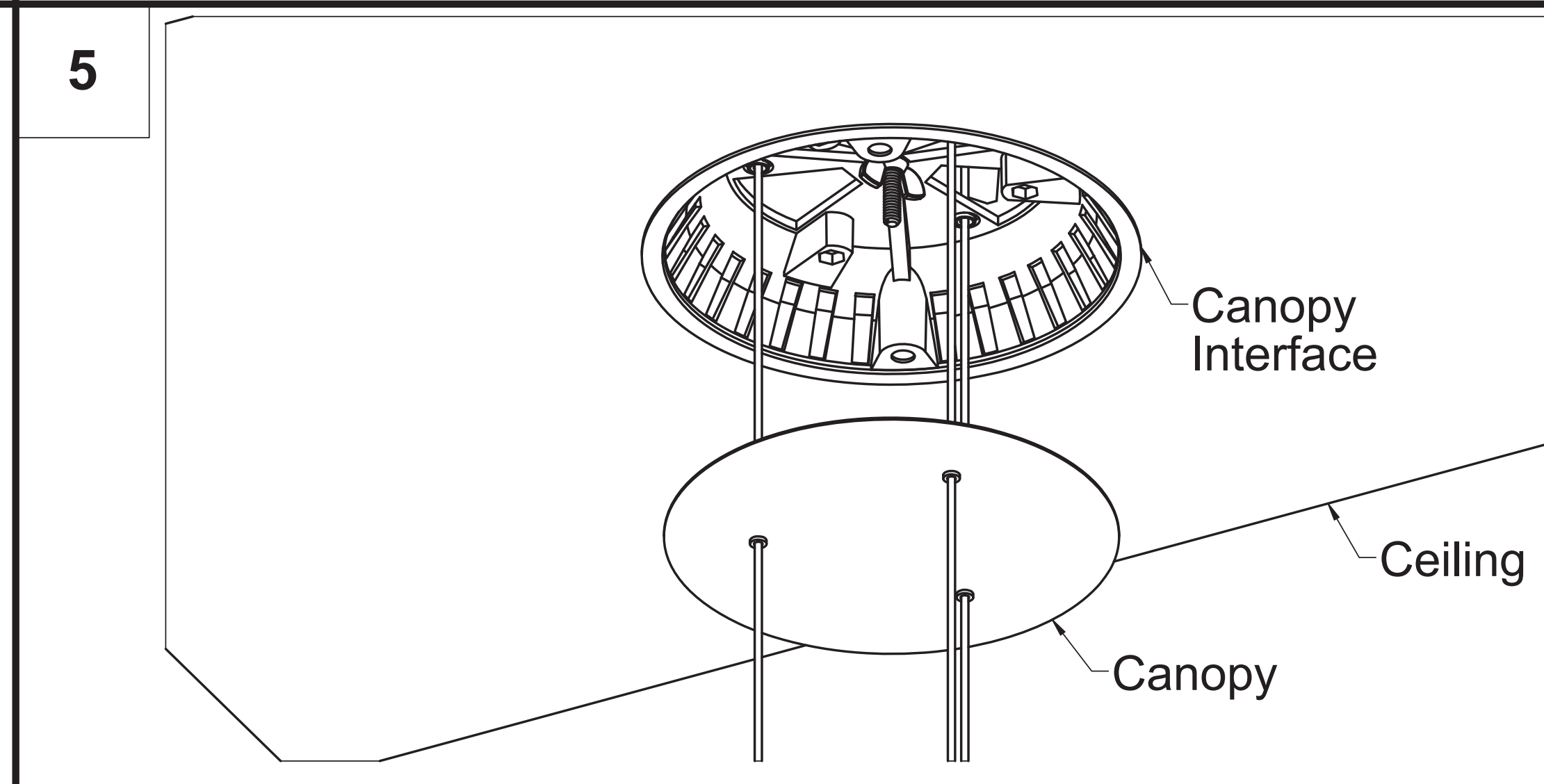

1. Push the **canopy** up to the ceiling
 2. Adjust the canopy so that it's centered against the **canopy interface**.
- Note: The canopy secures to the interface with pre-installed magnets. Refer to fixture installation instructions for fixture attachment with the cables.

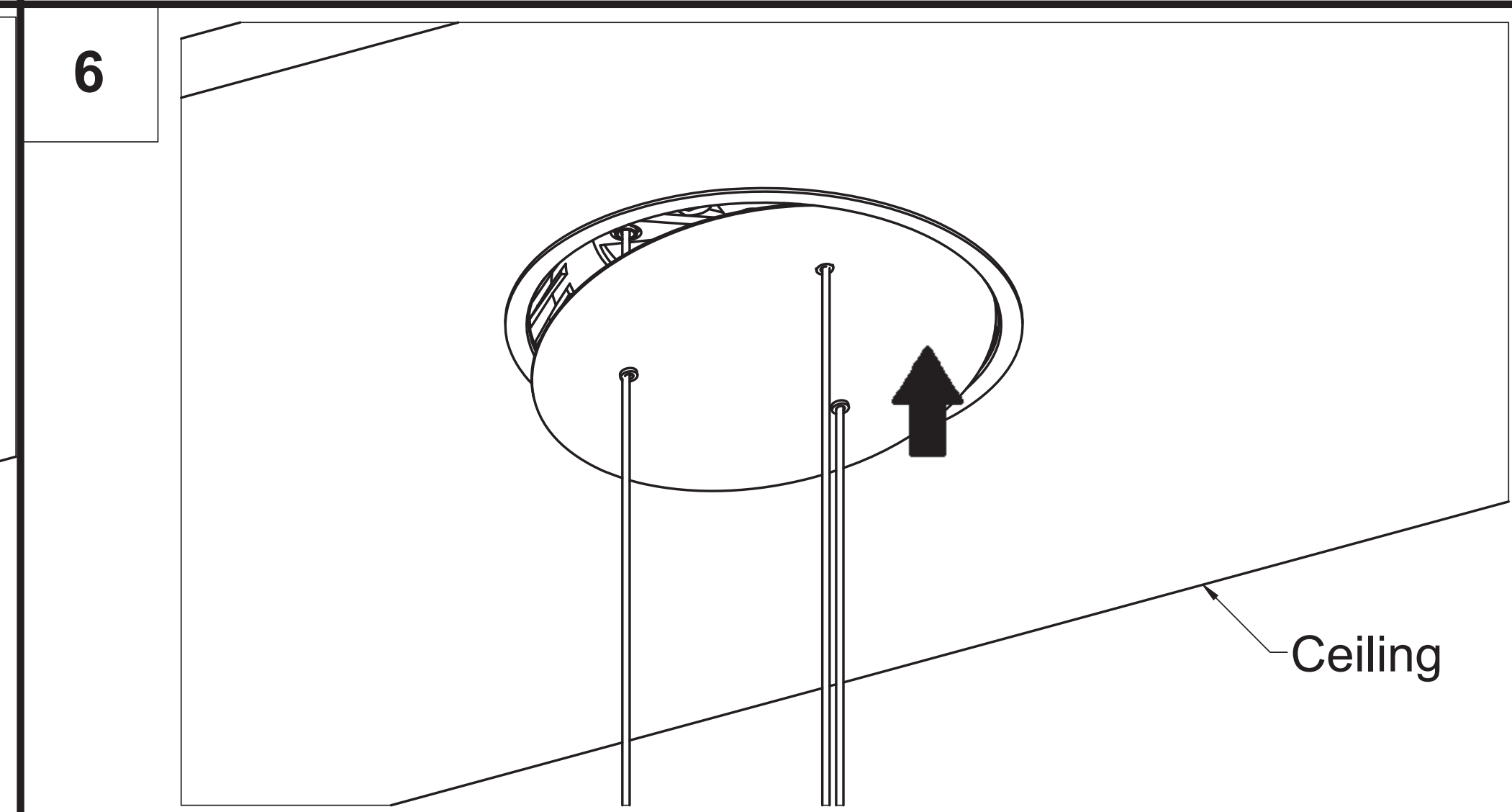

For removal of the canopy, press against the surface to displace it and then pull it away from the magnets. Reverse these instructions to uninstall the J-box.

Completed J-box installation should match **Figure 1** on page 10.

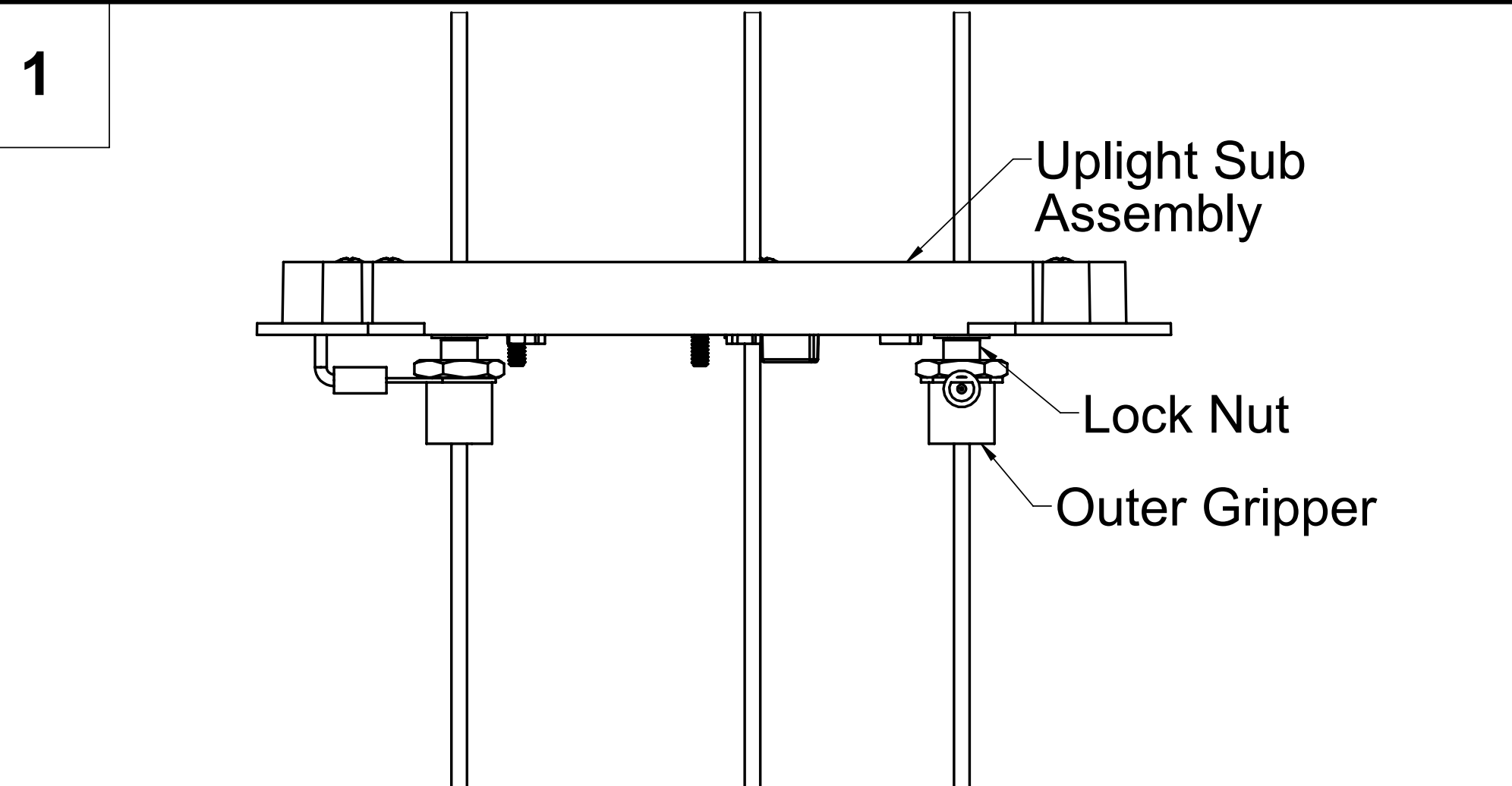

1. Once the J-box has been properly installed, lower the **Uplight Sub Assembly** to the desired fixture height by adjusting the outer grippers below it (adjust grippers by loosening lock nuts and pressing them against grippers)
 2. Level the assembly
Note: For configurations with no Uplight there will only be 1 Outer Gripper
The minimum height from the ceiling is 12" (see step 8 for visual reference). The top of the Uplight sub assembly will be flush with the top of the cylinder after the fixture has been fully installed.

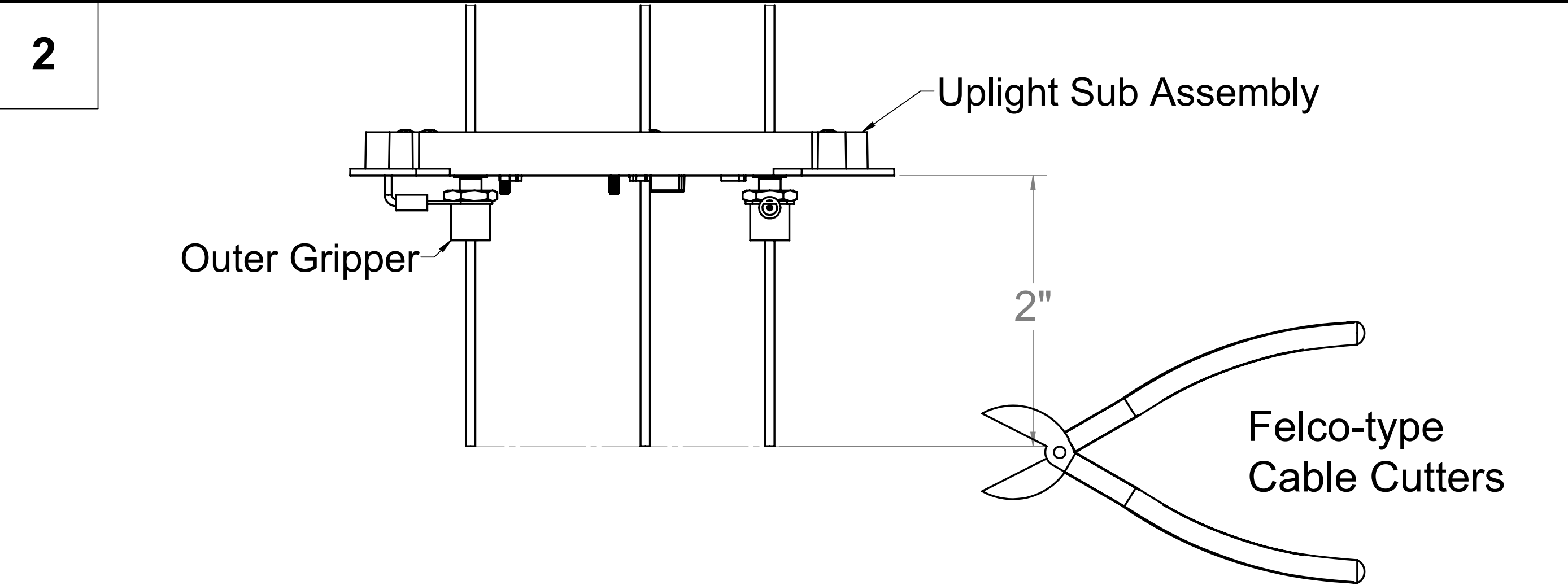

1. Measure 2" below the **Uplight Sub Assembly** and mark the location with a permanent marker
 2. Cut the cables at the marked location using **FELCO-TYPE CABLE CUTTERS**.

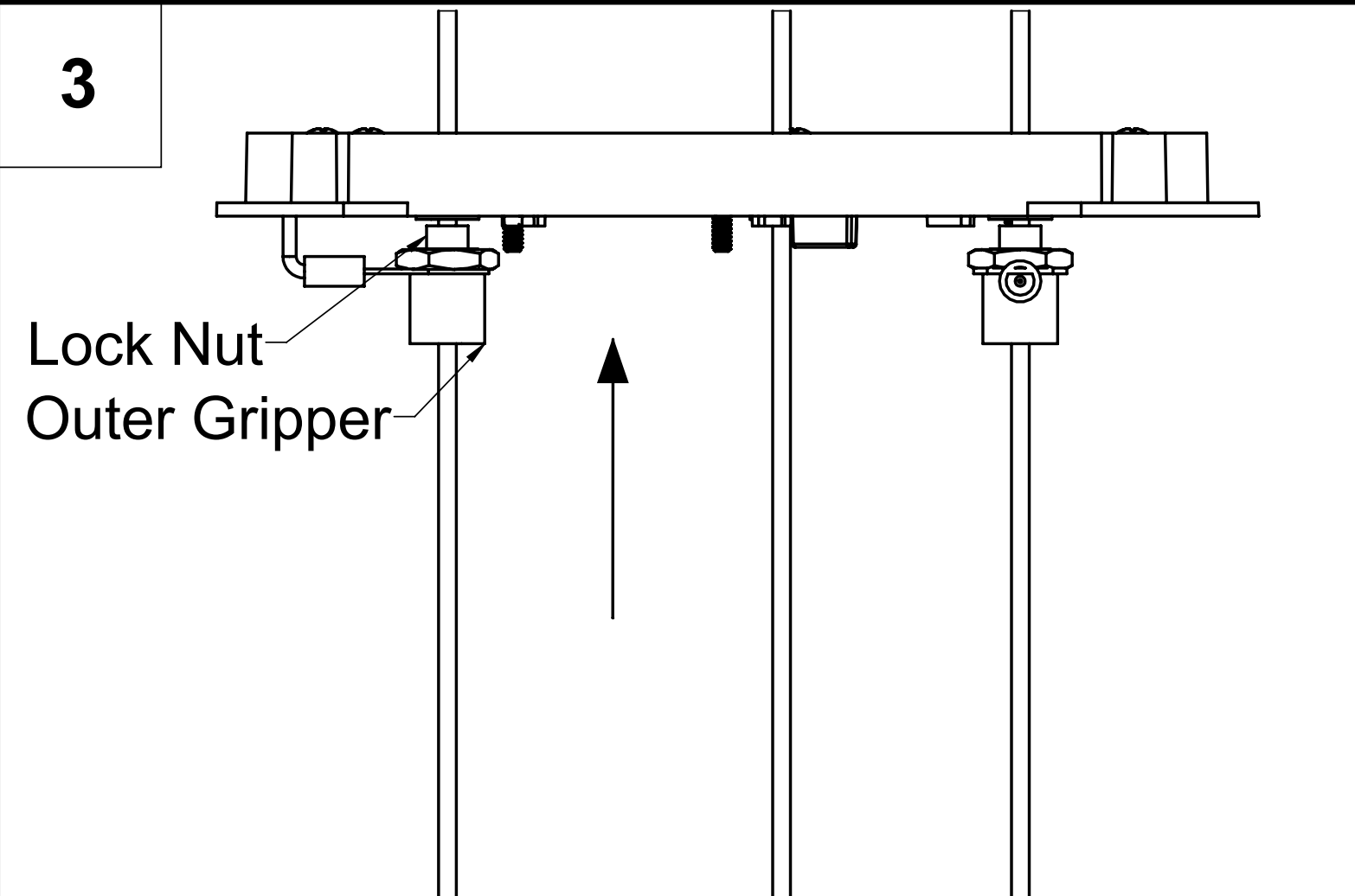

1. Move the **Uplight Sub Assembly and Outer grippers** up and out of the way temporarily by loosening **lock nuts** and pressing them against the grippers

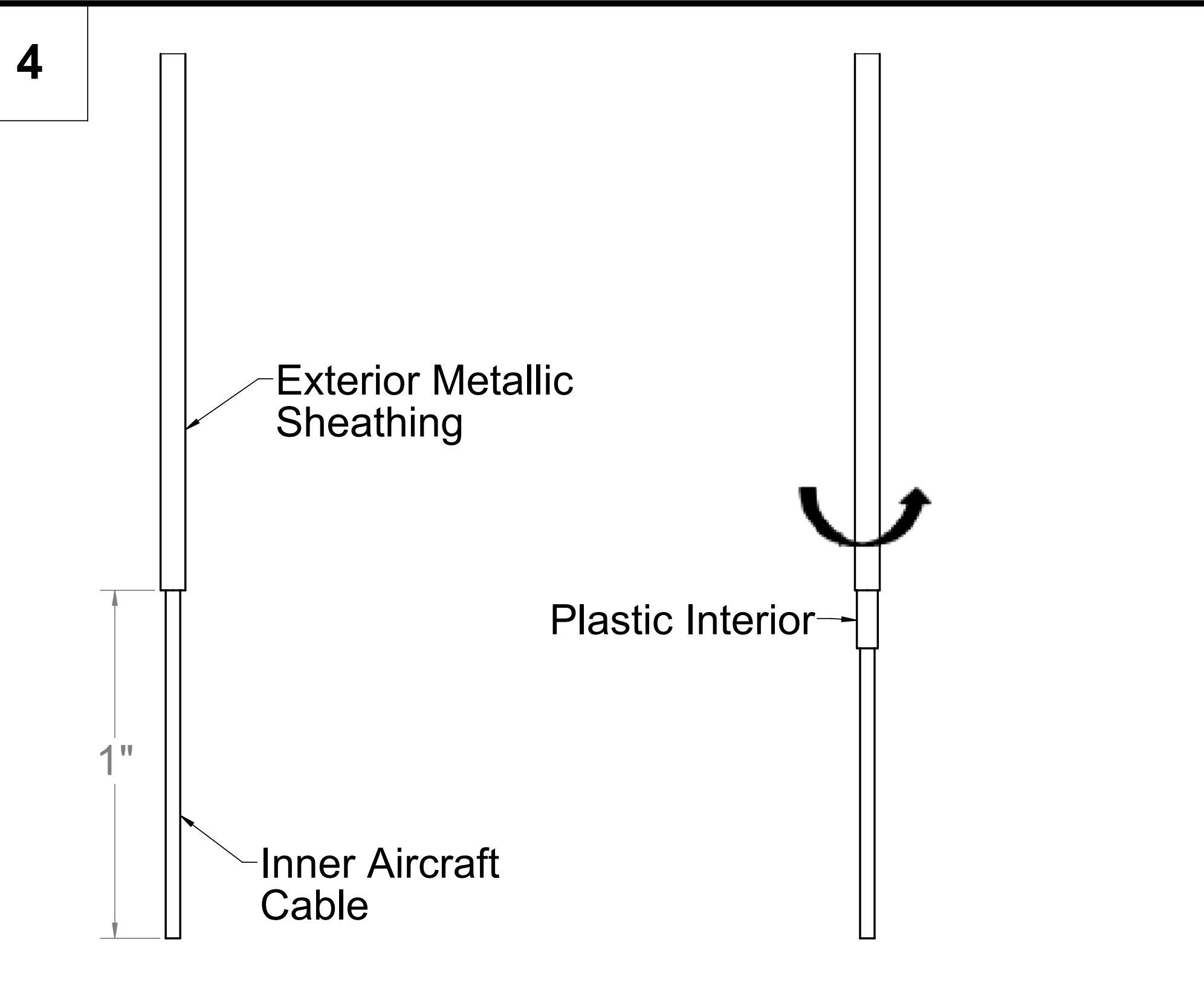

1. Measure 1" from bottom of the cable and mark the location
 2. Strip 1" of the metallic exterior and plastic interior off of the coaxial cable (using 16 gage wire strippers), leaving 1" of the **inner aircraft cable** exposed. (Left Image)
 3. Twist and move the **metallic exterior jacketing** up so that 1/8" to 1/4" of the **plastic interior** is exposed.
IMPORTANT: Do not let the exterior metallic sheathing and the inner aircraft cable touch. (Right Image)

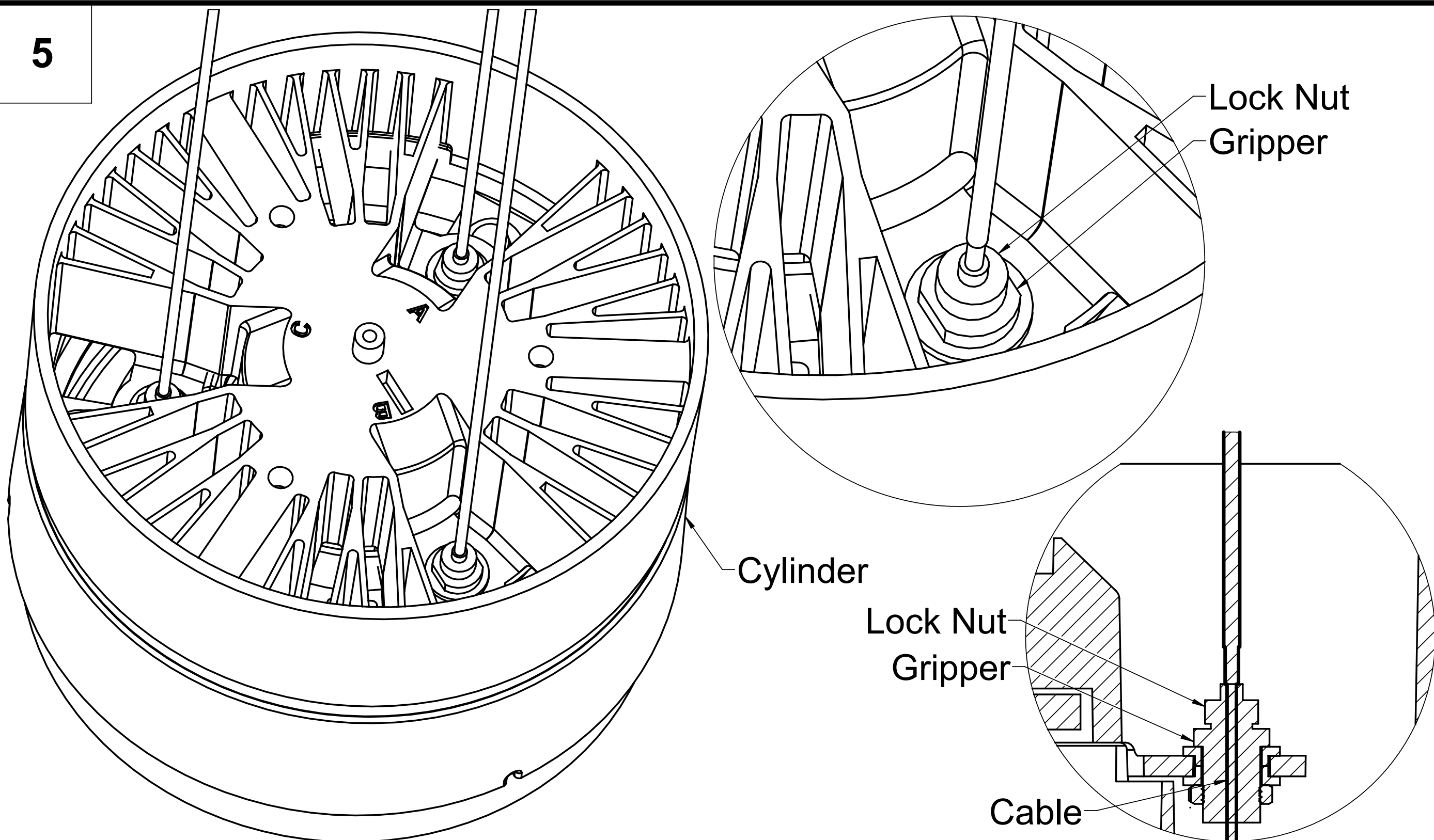

1. Match the letter indicators on the **Uplight Sub Assembly** with the letters on the Cylinder to ensure correct fixture orientation.
 2. Loosen the **Gripper Lock Nuts**
 3. Feed the cables into their respective grippers as far as they'll go
 4. Check that the Cylinder is level and adjust the cables accordingly before fully securing the gripper lock nuts.

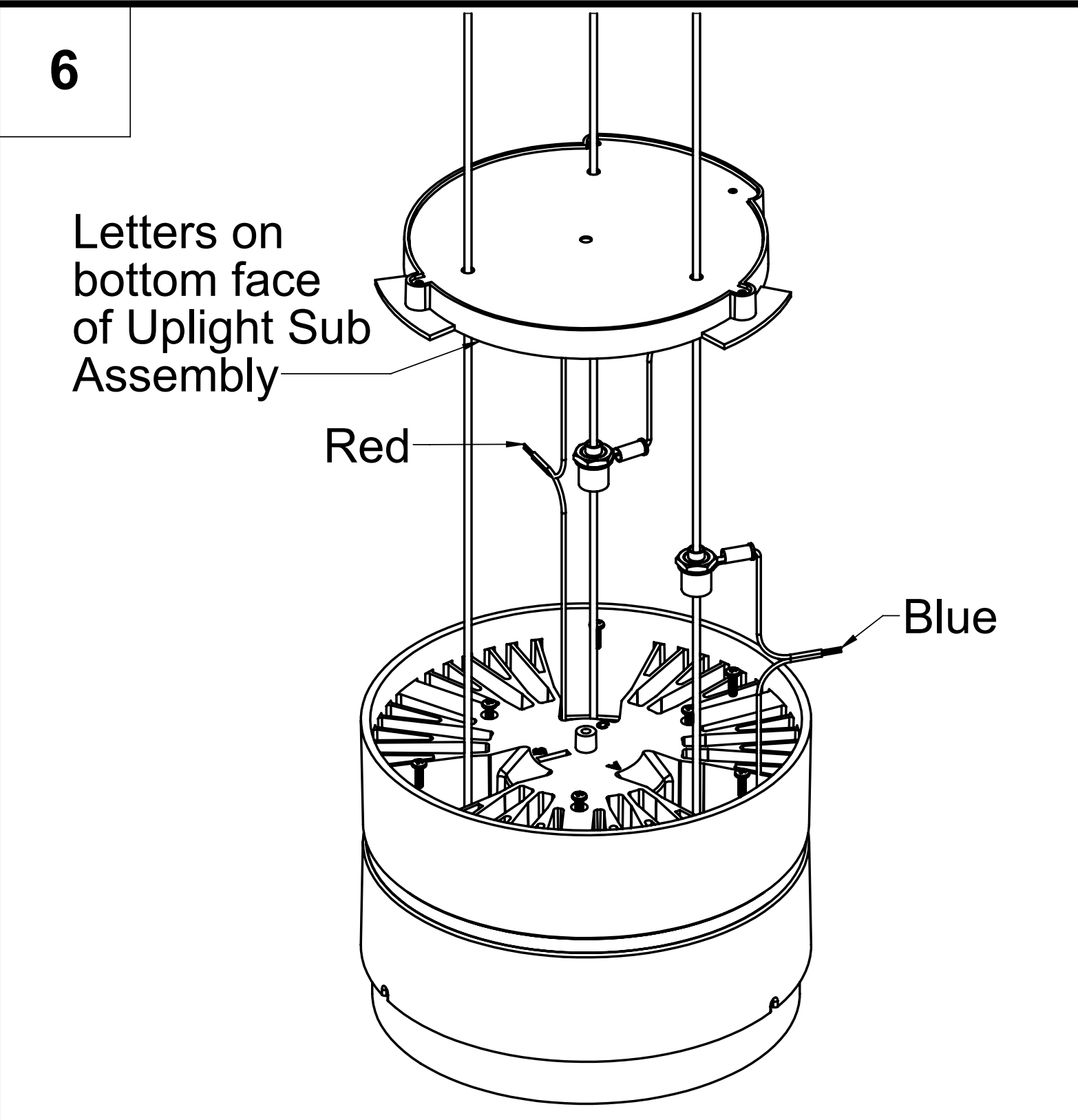

1. Make the wiring connections as shown in the above image between the blue and red wires in the Cylinder and Uplight Sub Assembly. **If there is no uplight, no wiring is required to the Uplight Sub Assembly (no red wire connections).**
 2. Using three wire nuts, connect red wire with red wire, and each blue wire with respective blue wire according to the alignment between the Cylinder and the Uplight Sub Assembly.

7

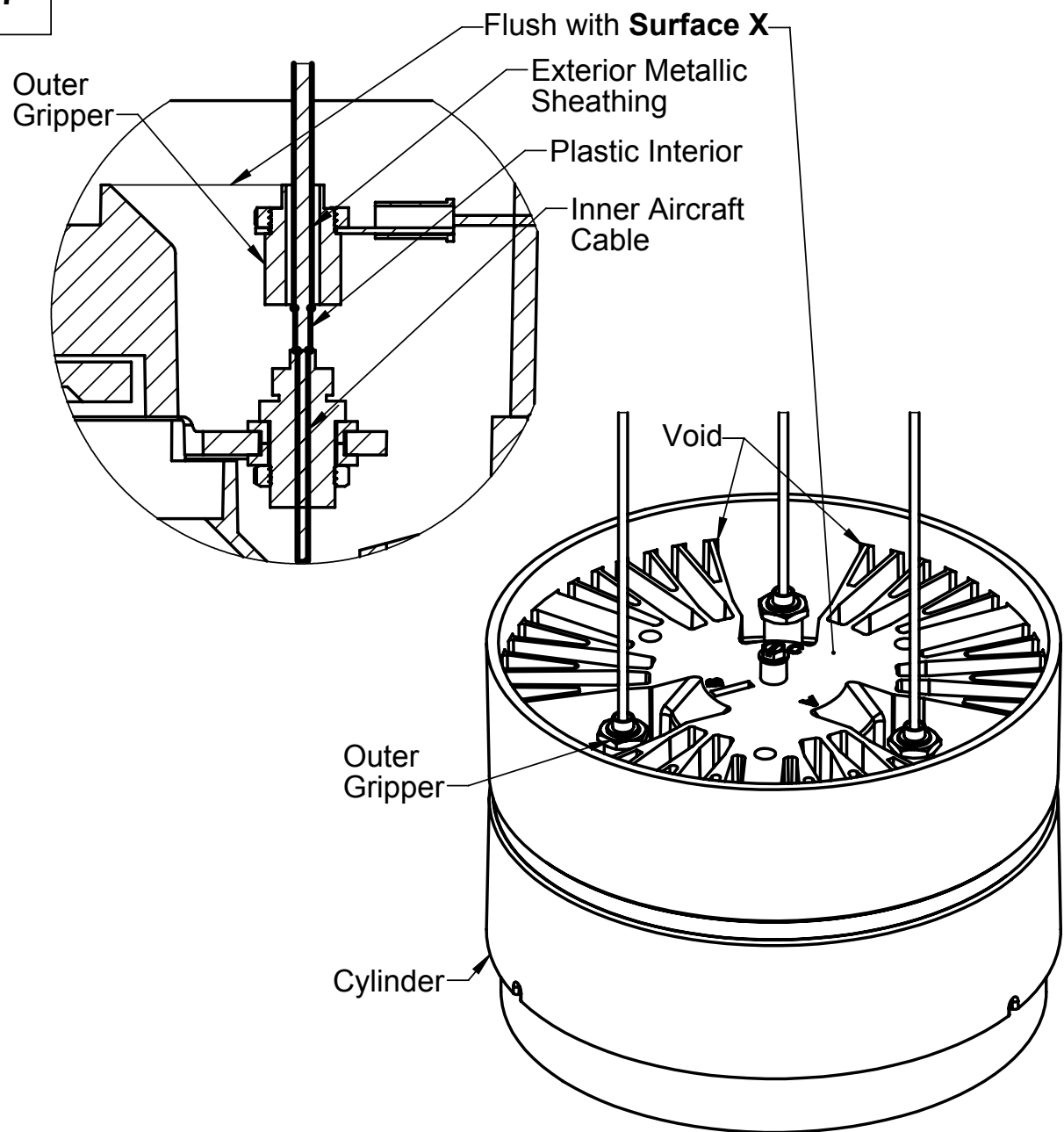

8

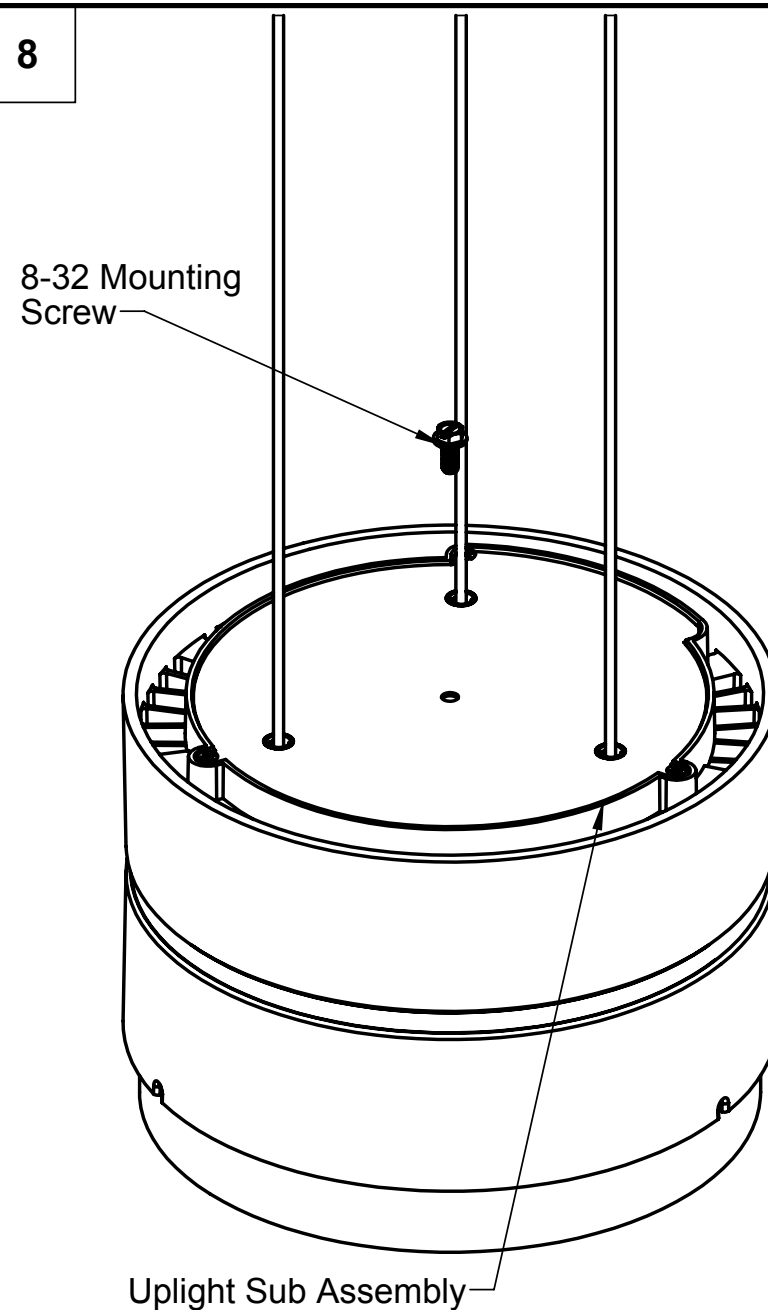

9

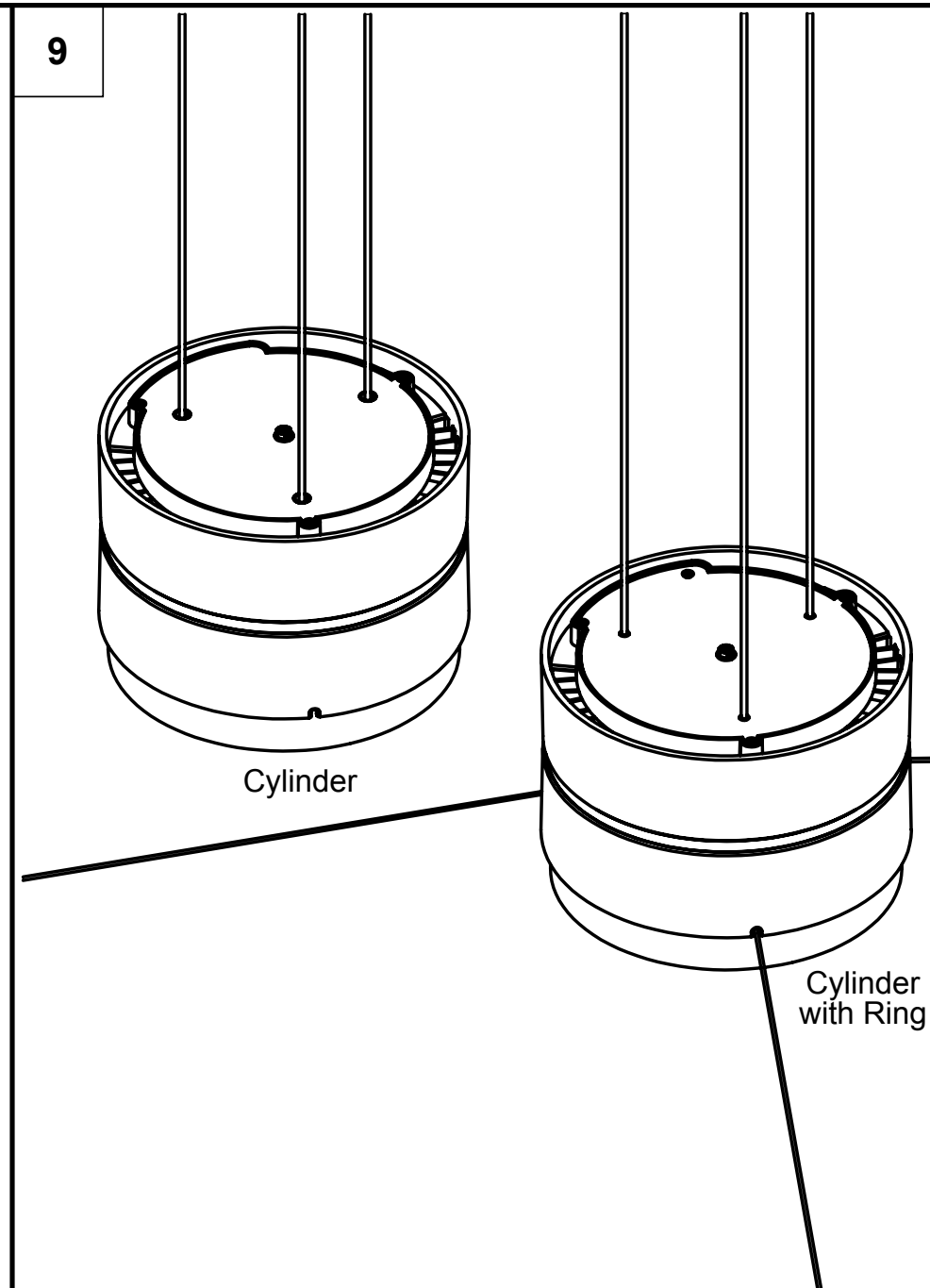

1. **Lower the Outer Grippers** so that they are inside the voids and flush with **Surface X**. The Outer Grippers should not be exposed at all above the voids.

Note: If the Outer Grippers come off of the Exterior Metallic Sheathing and are no longer making contact with it, secure them back on the cables by removing the cable from the gripper completely, removing the Outer Gripper, twisting/tightening the Exterior Metallic Sheathing, and putting the Outer Gripper back on the cable by completely loosening the plastic cap on the gripper and feeding the cable into the Outer Gripper while twisting the Outer Gripper. **The Outer Grippers must be in contact with the Exterior Metallic Sheathing for the fixture to illuminate.**

1. Remove the **8-32 Mounting Screw** from the **Cylinder**.
2. Lower the **Uplight Sub Assembly** onto the Cylinder
3. Reinstall 8-32 mounting screw thereby securing the Uplight Sub Assembly to the Cylinder.

For Cylinder only fixture (left), the installation is now complete. Reverse instructions to uninstall fixture and J-box.

For Cylinder with Ring fixture (right), see Ring installation sheets to complete installation.

Completed Cylinder installation should match **Figure 2** on page 9.

Figure 1
Completed J-box installation

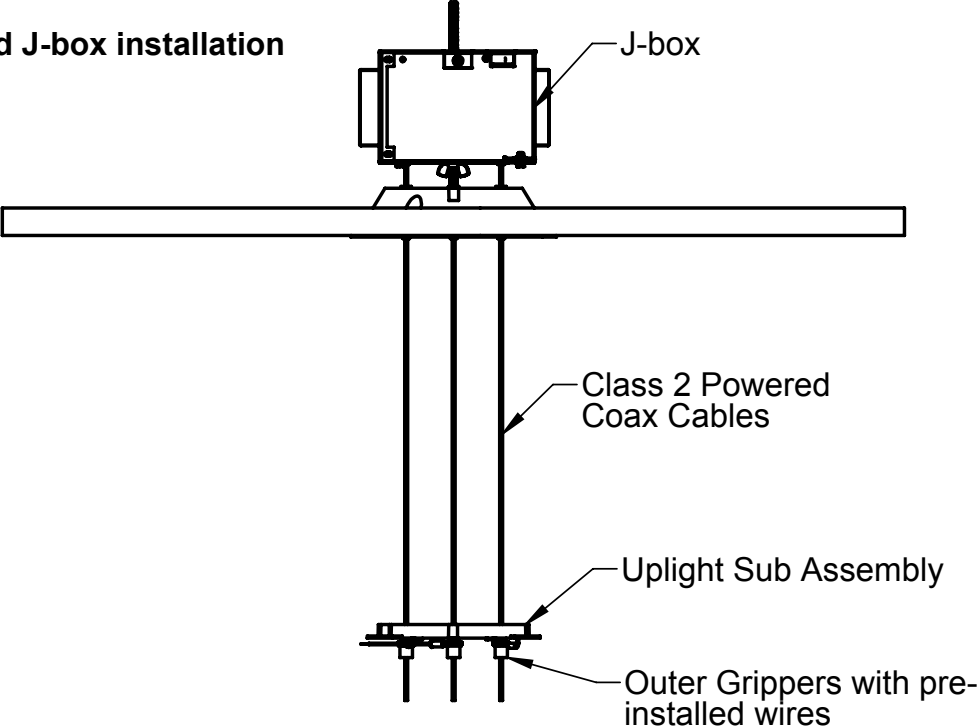
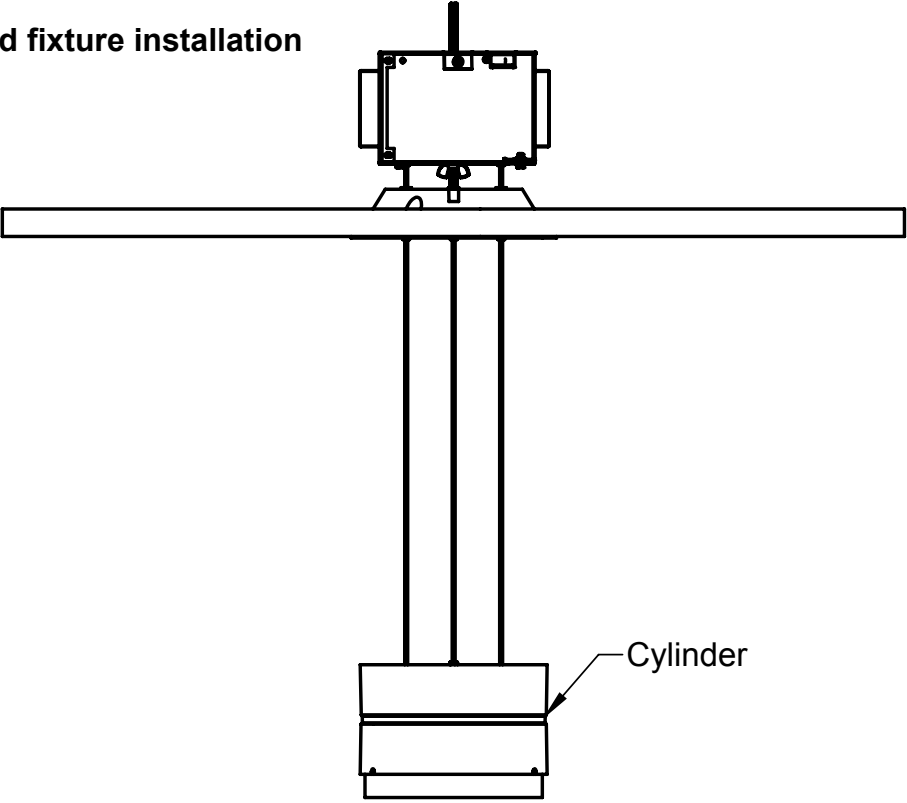
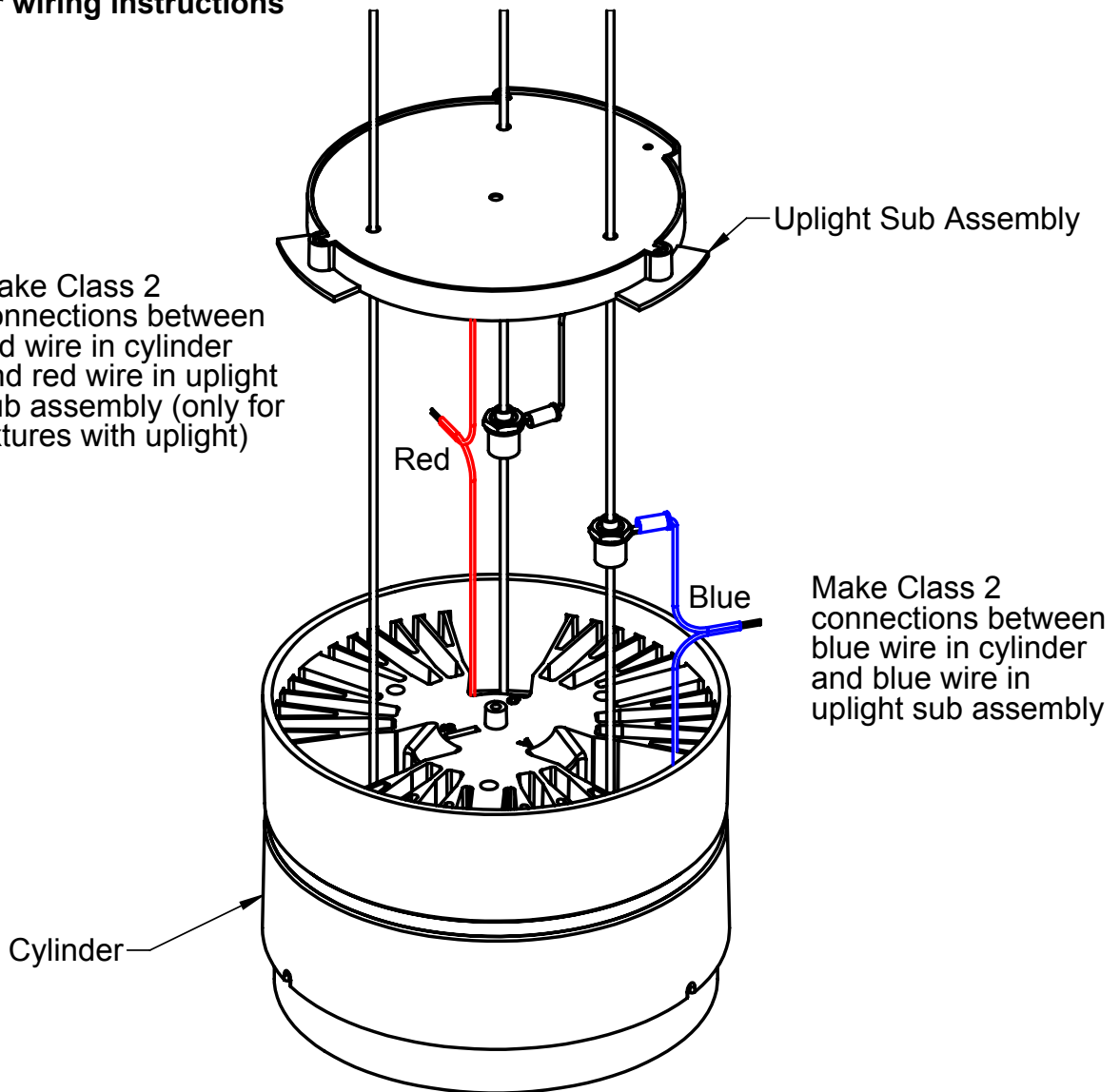

Figure 2
Completed fixture installation



Cylinder wiring instructions

Make Class 2 connections between red wire in cylinder and red wire in uplight sub assembly (only for fixtures with uplight)



WIRING DIAGRAMS

APPLICABLE FIXTURE TYPES:

- 32L-C-P-ID

STANDARD WIRING
(CAN ALSO BE USED IN NIGHTLIGHT APPLICATIONS)

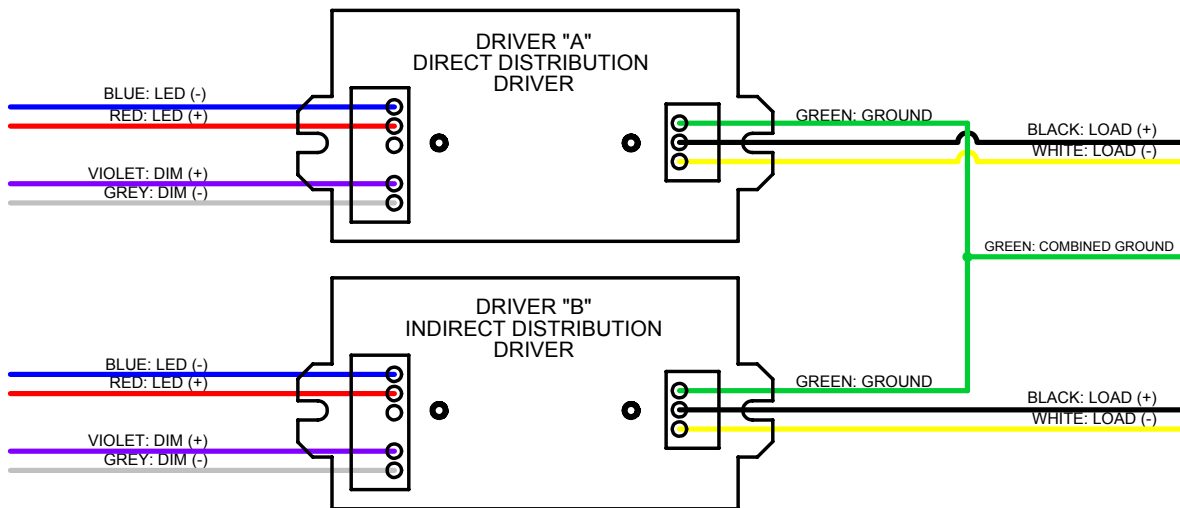

ALTERNATIVE FIELD WIRING OPTIONS

SINGLE CIRCUIT SUPPLY WIRING

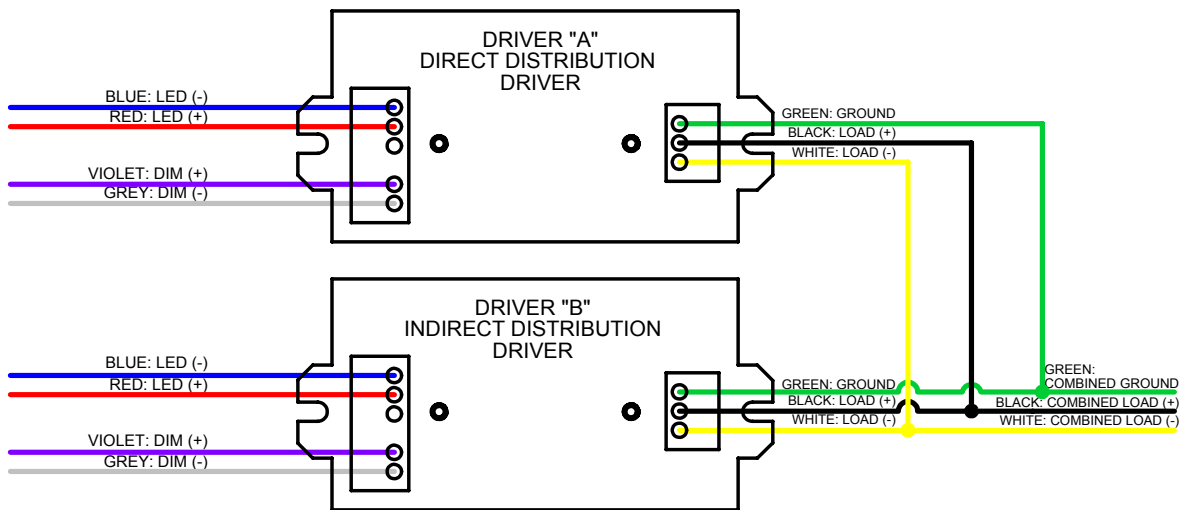

WIRING DIAGRAM

(NO UPLIGHT)

APPLICABLE FIXTURE TYPES:

- 32L-C-P-D

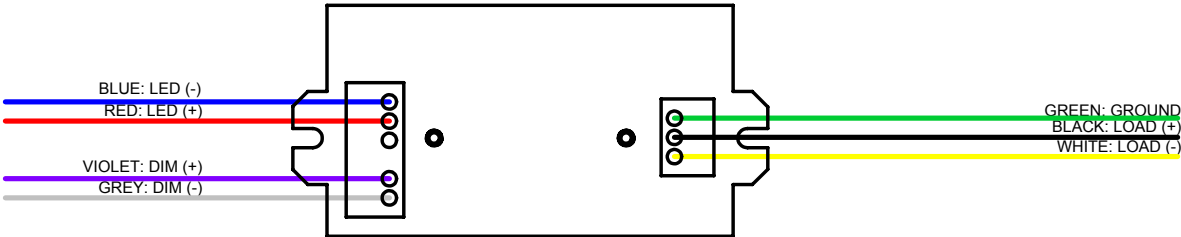

Cylinder Label Positioning

If fixture is damaged or additional assistance is needed, call the number on the label to speak with a Litecontrol representative

**CONTACT LITECONTROL
FOR REPLACEMENT PARTS
781-294-0100**

MODEL: 32L
DATE: ___ / ___ / ___
CCT: _____

