

**GENERAL NOTES: (READ SHEETS COMPLETELY BEFORE STARTING)**

1. LEAVE PROTECTIVE WRAPPING MATERIAL ON FIXTURE UNTIL START OF INSTALLATION TO PROTECT FINISH FROM DAMAGE.
2. FIXTURES ARE SUPPLIED WITH FACTORY-INSTALLED BRANCH CIRCUIT WIRING. REFER TO SUPPLEMENTAL INSTRUCTION SHEET WHEN MAKING CONNECTIONS.
3. WALL SURFACE SHOULD BE FINISHED A MINIMUM OF 7" ABOVE CEILING.
4. WALL ANGLES ARE SHIPPED IN 96" LENGTH CUT TO SUIT FIELD CONDITIONS. **DO NOT DISCARD LEFTOVER CUT ANGLES.**

TOOLS REQUIRED	SUPPLIED BY INSTALLER
<ul style="list-style-type: none"> <li>- WIRE CUTTER/STRIPPER</li> <li>- TAPE MEASURE</li> <li>- METAL CUTTING TOOL (SAW-TYPE)</li> <li>- SCREWDRIVER/DRILL</li> <li>- TIN SNIPS</li> <li>- CHALK</li> </ul>	<ul style="list-style-type: none"> <li>- POWER FEED</li> <li>- PENNY NAILS OR EQUIVALENT</li> <li>- DRYWALL SCREWS</li> <li><i>IF NECESSARY:</i></li> <li>- SHIMS</li> <li>- GUY WIRES</li> <li>- J-ANGLE</li> </ul>

# SUPPORT RAIL INSTALLATION

SUPPORT RAIL(S) MUST BE INSTALLED PRIOR TO INSTALLATION OF FIXTURE(S).

1

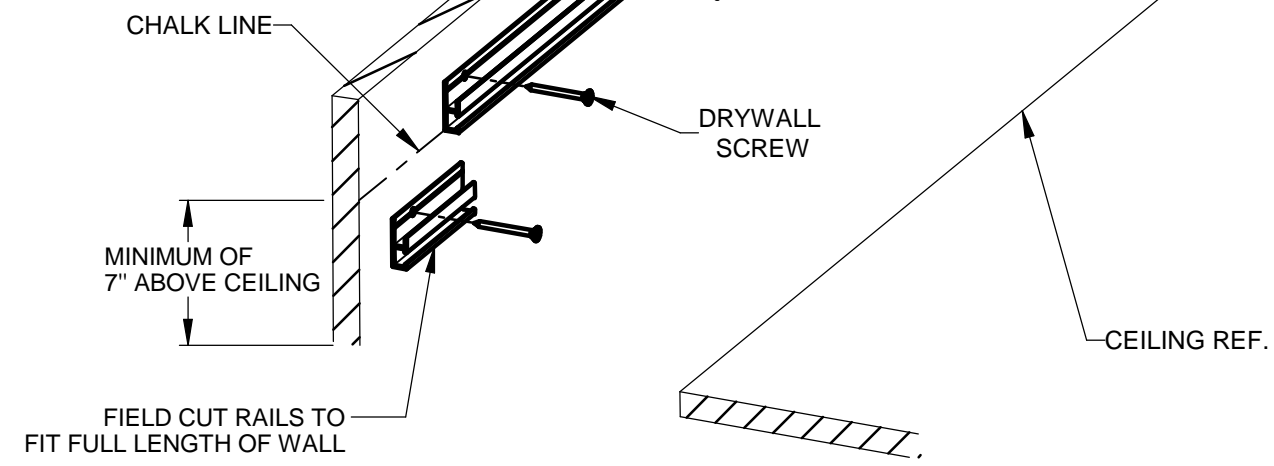
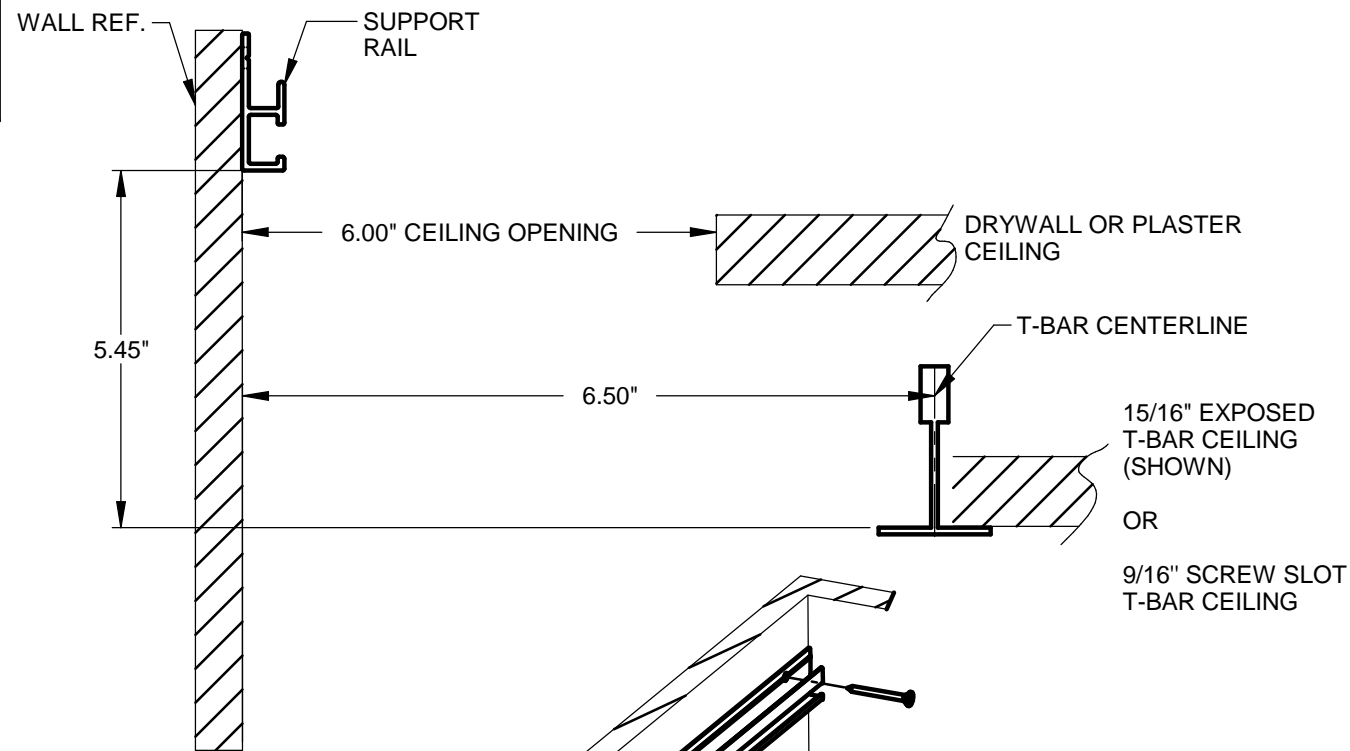

MARK LEVEL CHALK LINE AT DESIRED HEIGHT ABOVE CEILING ALONG FULL LENGTH OF WALL. POSITION BOTTOM EDGE OF SUPPORT RAIL ON CHALK LINE. FASTEN SUPPORT RAIL TO WALL USING DRYWALL SCREWS.

2

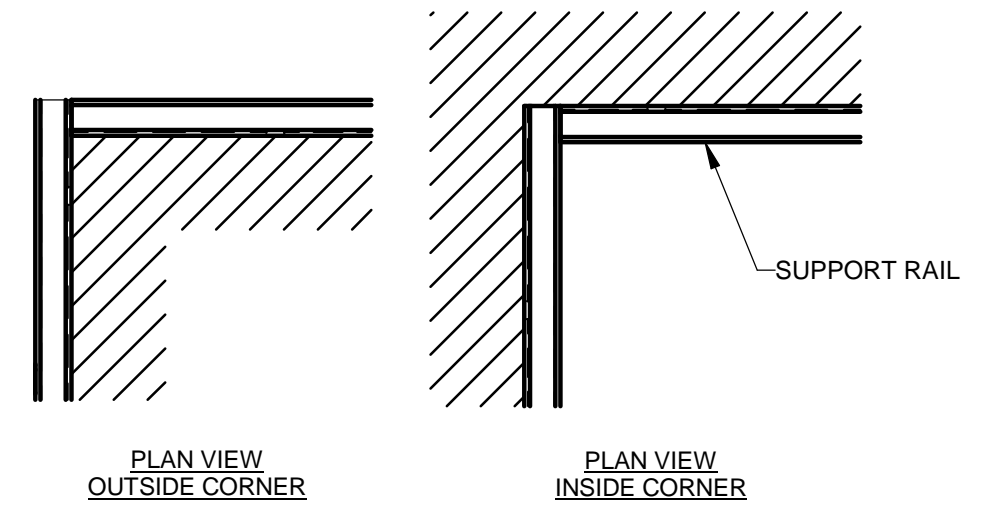

BUTT EDGES OF SUPPORT RAILS AT CORNERS AS SHOWN ABOVE.

3

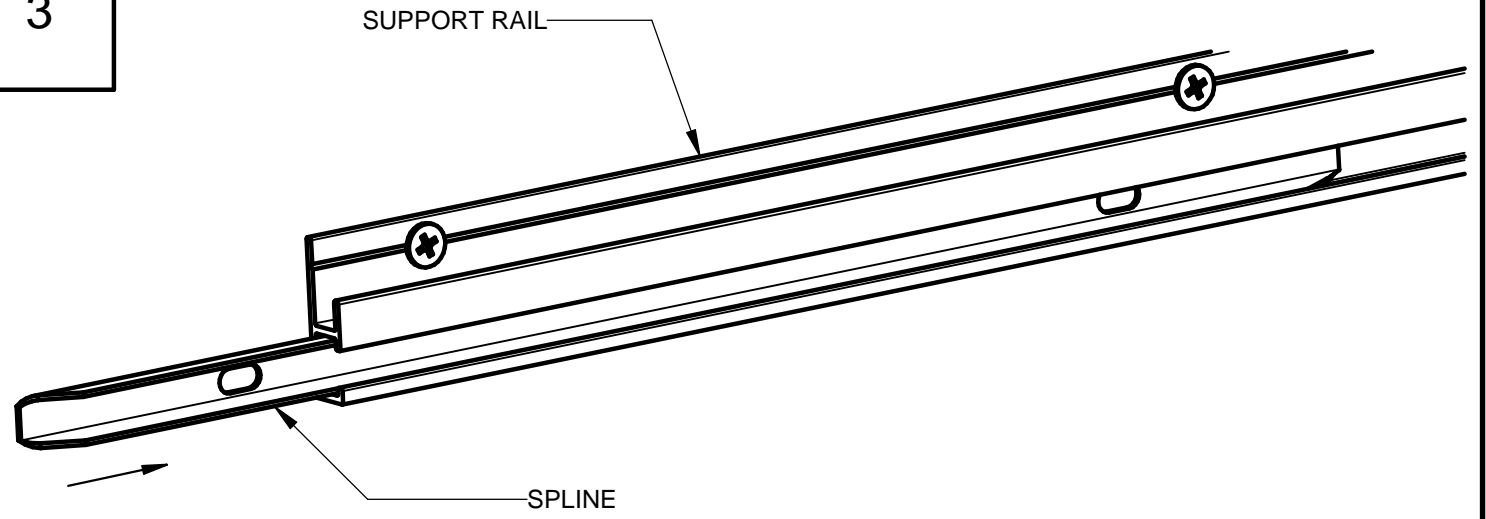

INSERT SPLINE KEYS BETWEEN ADJACENT SUPPORT RAILS AS EACH LENGTH IS ADDED. IF NECESSARY, SHIM BEHIND SUPPORT RAILS TO FORM A CONTINUOUS STRAIGHT RAIL.

# WALL ANGLE INSTALLATION

FOR "R" POSITION ONLY.

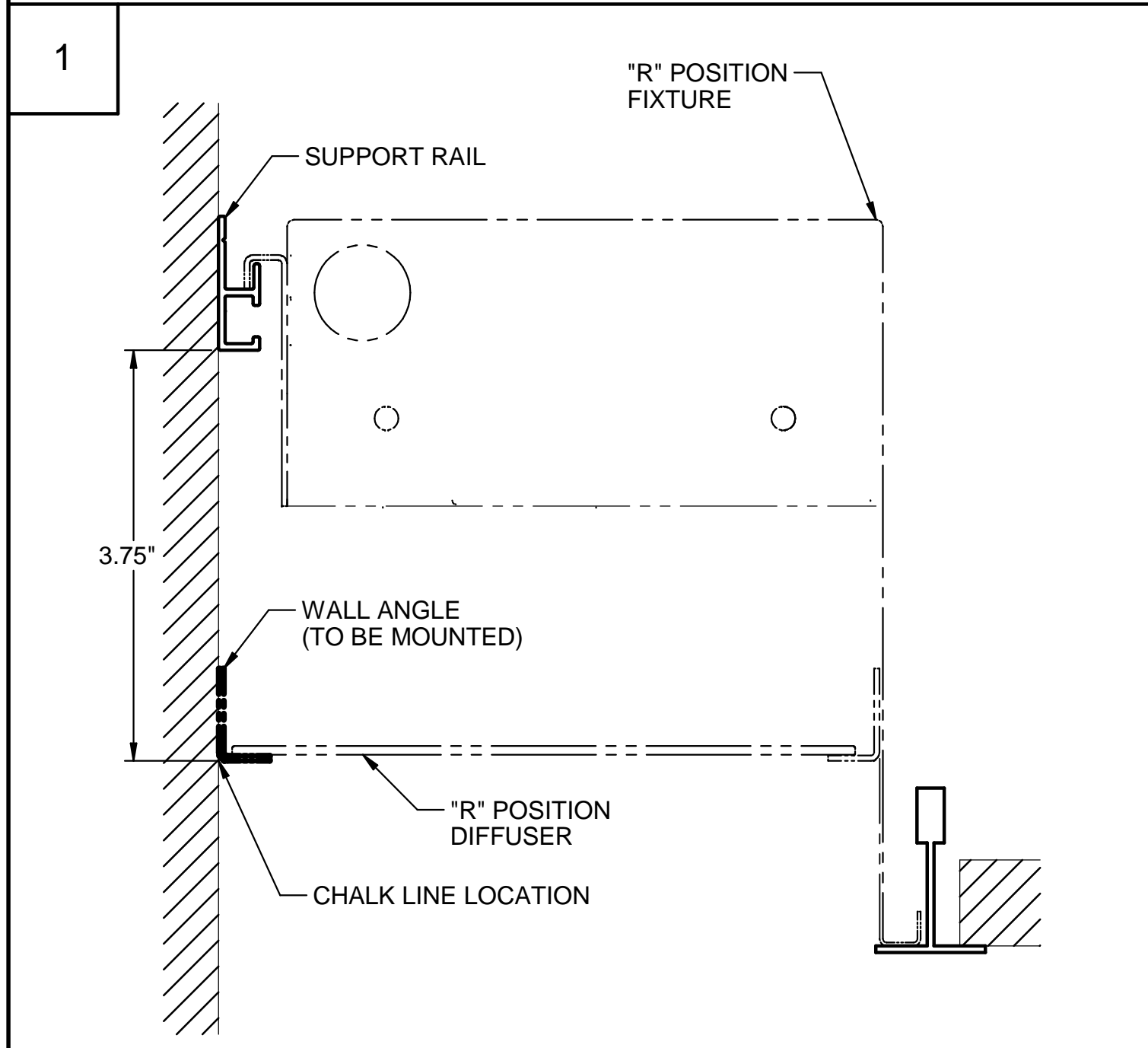

MARK A LEVEL LINE 3.75" BELOW BOTTOM EDGE OF SUPPORT RAIL ALONG FULL LENGTH OF WALL. LINE WILL BE USED FOR POSITIONING OF BOTTOM EDGE OF WALL ANGLE.

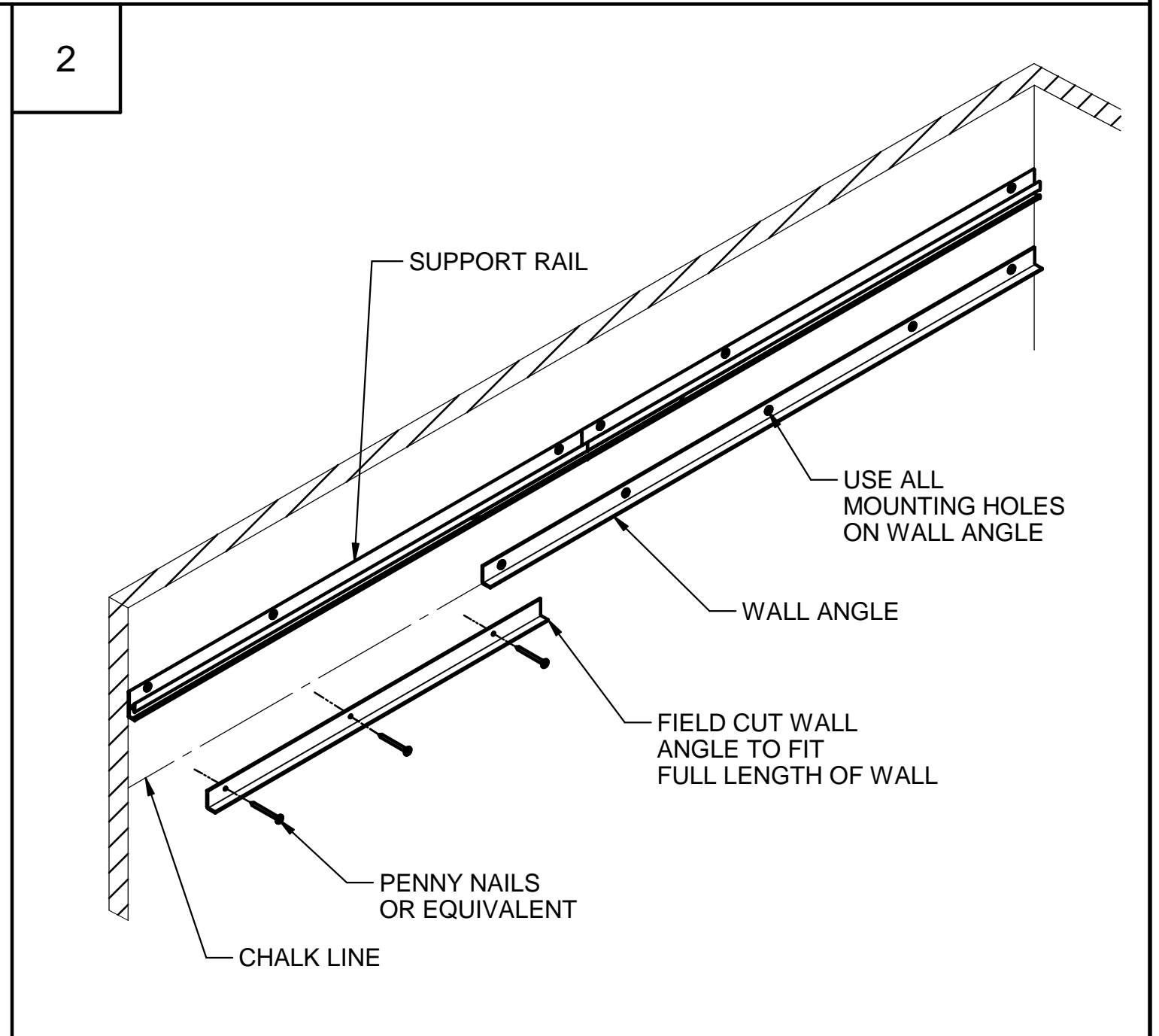

POSITION BOTTOM EDGE OF WALL ANGLE (CUT TO LENGTH) ON CHALK LINE. FASTEN TO WALL USING PENNY NAILS OR EQUIVALENT AT ALL MOUNTING HOLES. IF NECESSARY, SHIM BEHIND WALL ANGLES/COLOR SHIELD TO FORM CONTINUOUS STRAIGHT LINE. BUTT EDGES OF WALL ANGLES/COLOR SHIELD AT CORNERS (REFER TO PAGE 2, STEP 2).

1

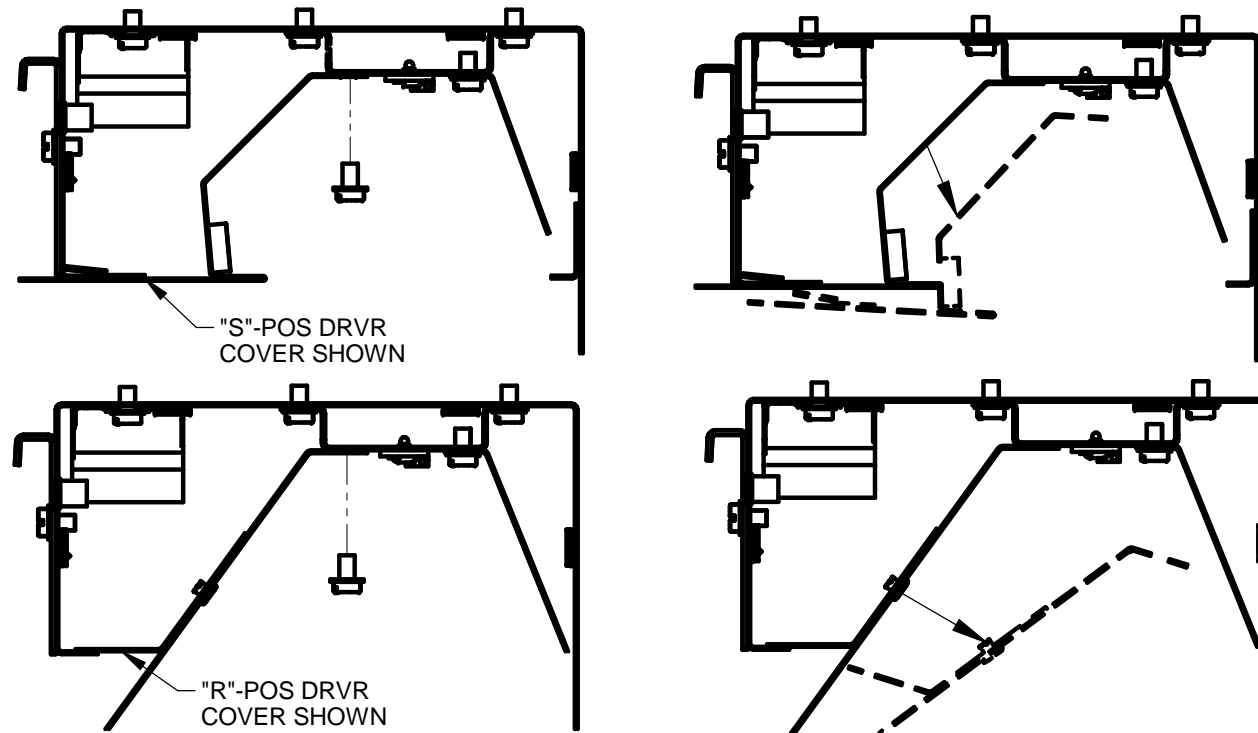

REMOVE DRIVER COVERS BY UNSCREWING SHEET METAL SCREWS. SLIDE AND ROTATE COVER AT FIXTURE HOUSING.

2

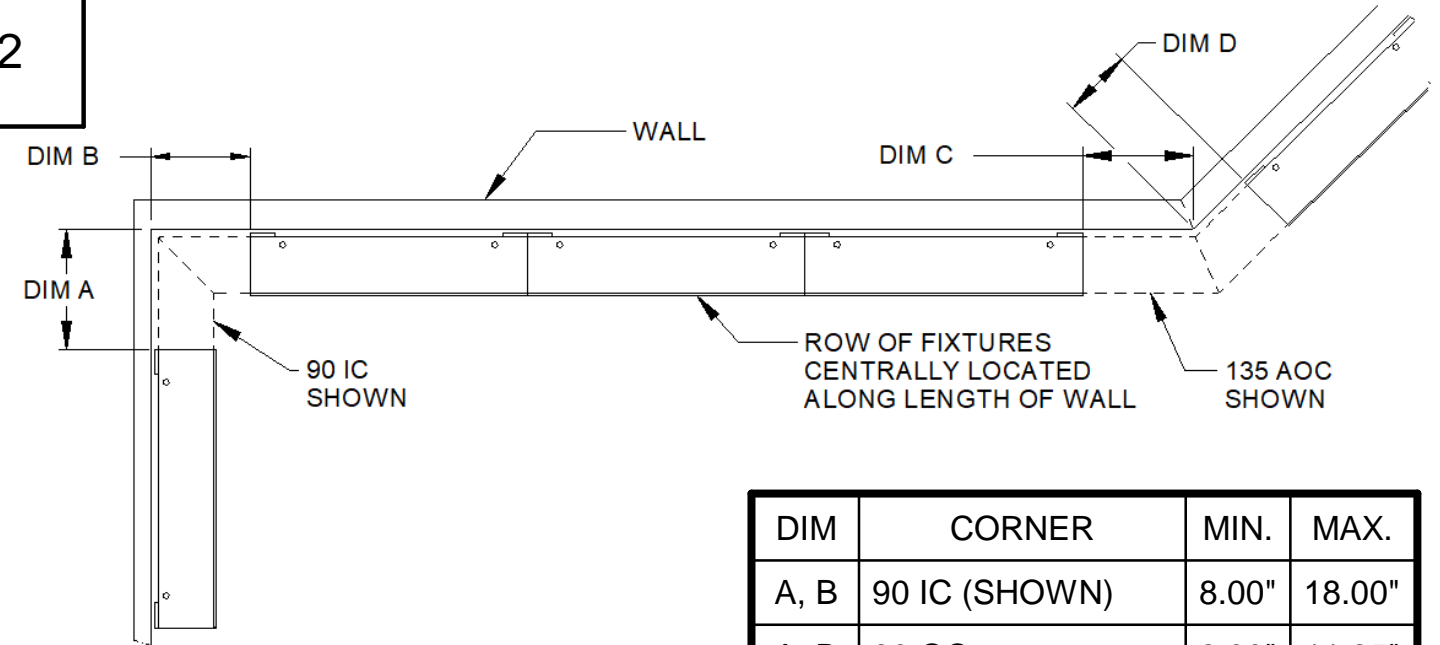

INSTALL ALL SYSTEM CONNECTORS (SHIPPED SEPARATELY). REATTACH ALL DRIVER COVERS AND ATTACH END CAPS (SEE PAGE 8).

DIM	CORNER	MIN.	MAX.
A, B	90 IC (SHOWN)	8.00"	18.00"
A, B	90 OC	2.00"	11.25"
C, D	135 AOC (SHOWN)	2.00"	11.50"
C, D	135 AIC	4.50"	14.50"

3

**DRYWALL CEILING ONLY:**

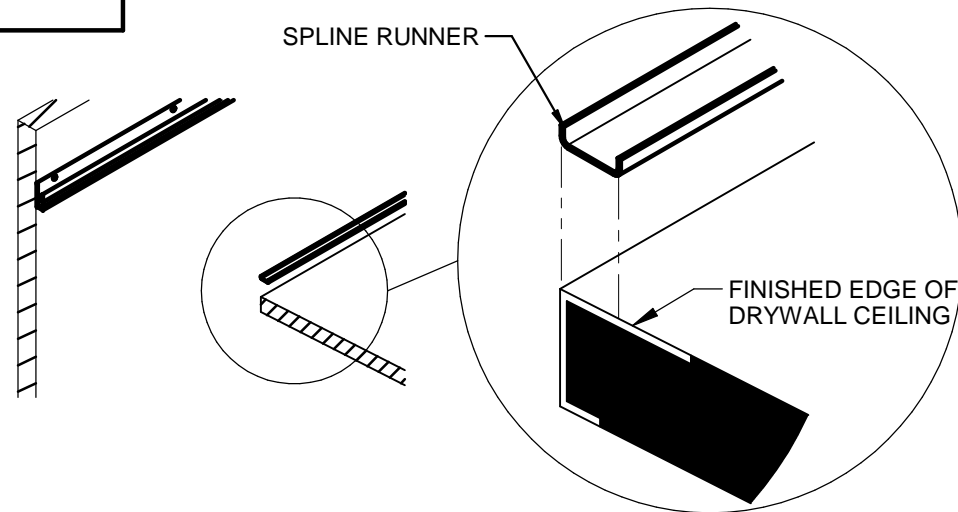

PEEL OFF ADHESIVE BACKING ON BOTTOM OF SPLINE RUNNERS AND ATTACH TO TOP SURFACE OF DRYWALL FLUSH WITH FINISHED EDGE. SPLINE RUNNERS ARE SHIPPED IN 48" LENGTHS; FIELD CUT TO SUIT FULL LENGTH OF OPENING.

4

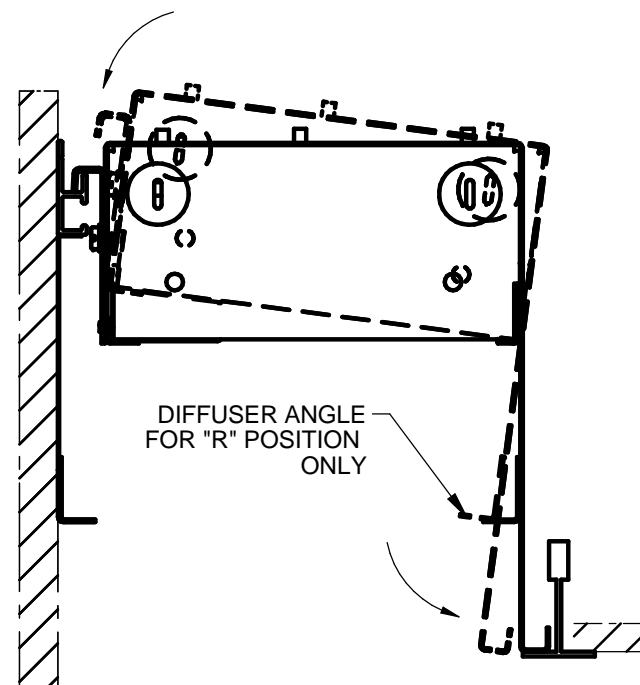

BRING FIXTURE INTO CEILING OPENING AND HOOK ONTO SUPPORT RAIL, TURNING UNTIL FIXTURE IS LEVEL.

5

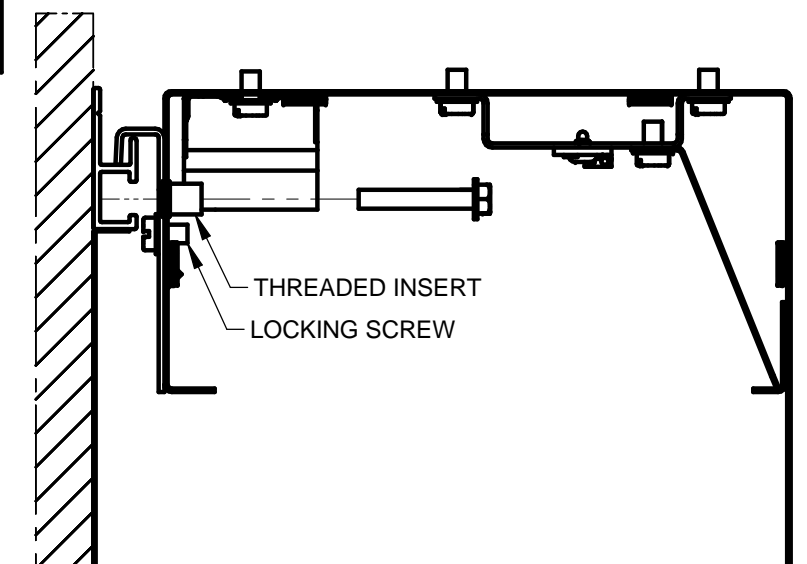

THREAD #8-32 X 1" LONG LOCKING SCREWS APPROX. 1/4" INTO EACH WELDNUT UNTIL FIXTURE IS LEVEL. ELECTRICAL FEED CAN BE ROUTED THROUGH 7/8" KNOCK-OUTS EITHER AT TOP OF HOUSING OR AT END HEADERS (SEE PAGE 1).

6

**GRID CEILINGS ONLY:**

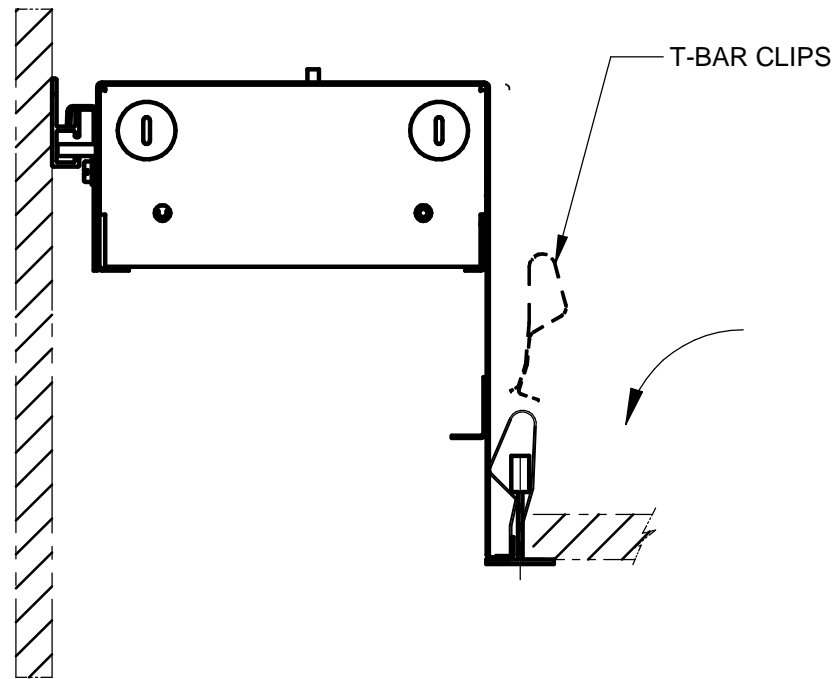

SNAP T-BAR CLIPS OVER T-BARS SUCH THAT THEY ENGAGE BOTTOM HEM OF FIXTURE. TWO CLIPS ARE REQUIRED FOR 24", 36", AND 48" FIXTURES; THREE CLIPS ARE REQUIRED FOR 72" AND 96" FIXTURES.

7

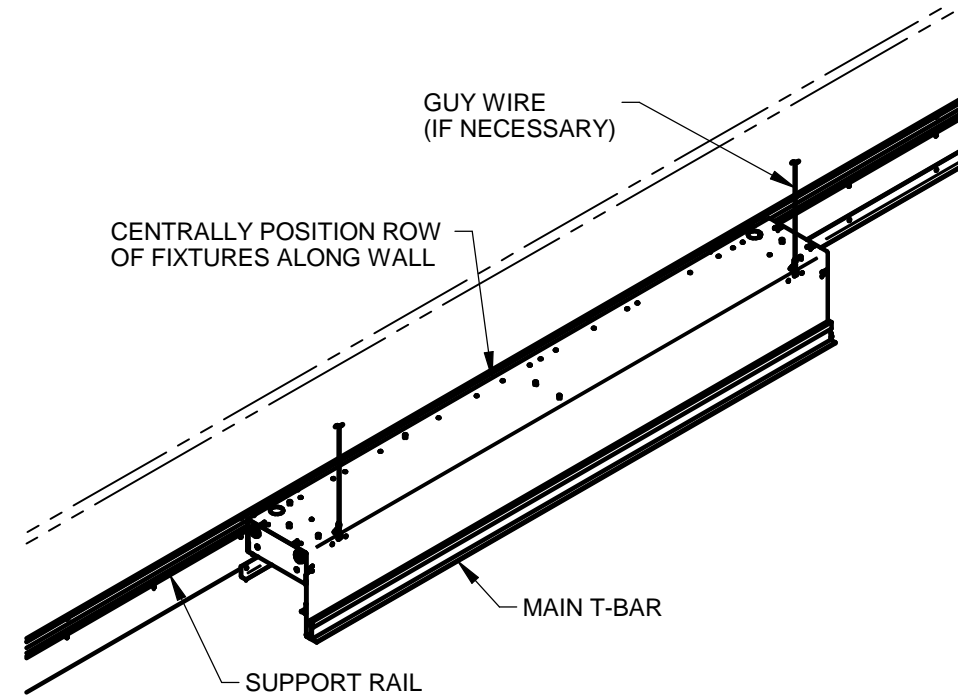

CENTRALLY LOCATE ROW OF FIXTURES WITHIN SPACE. SPACE BETWEEN ENDS OF FIXTURES AND OPPOSITE WALLS WILL BE FILLED IN BY SYSTEM CONNECTORS. USE GUY WIRES IF NECESSARY.

8

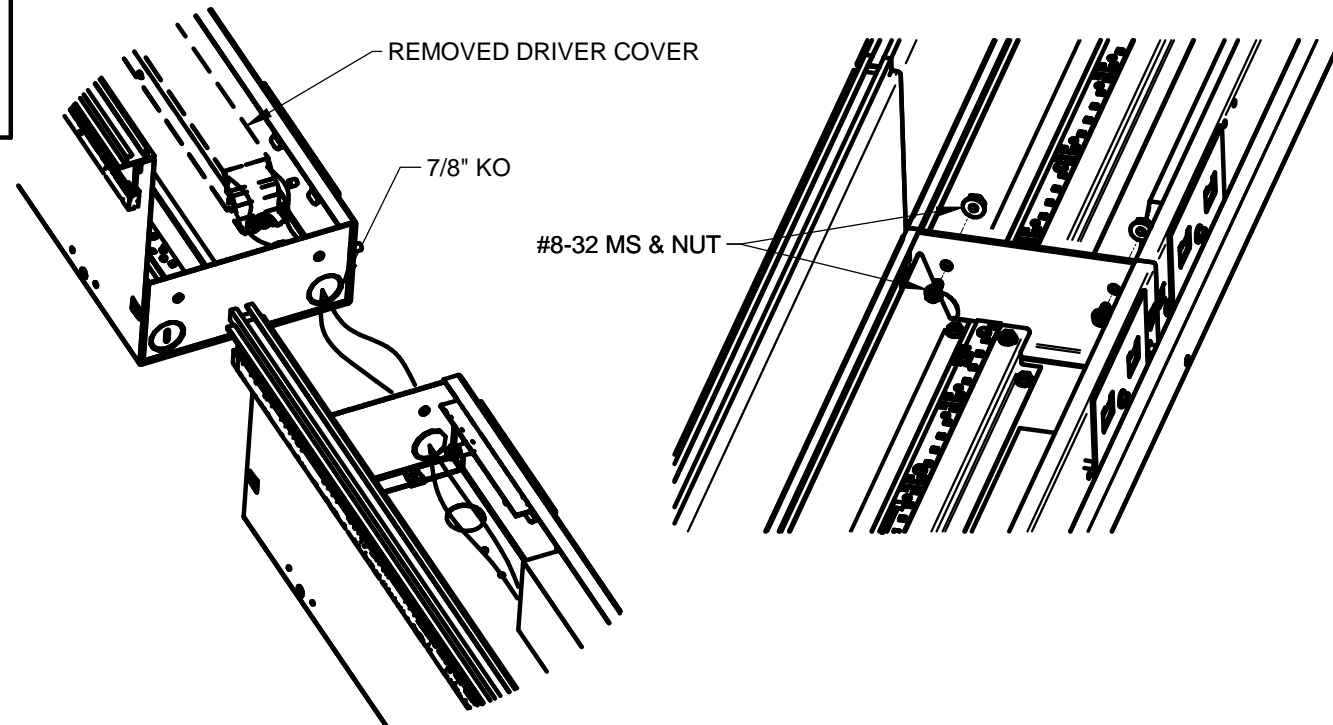

MAKE ELECTRICAL CONNECTIONS. AT ROW JOINTS, BRANCH CIRCUIT WIRING CAN BE ROUTED THROUGH 7/8" KNOCK-OUTS. MOUNT ADJOINING FIXTURES TOGETHER USING (2) #8-32 X 3/8" LONG MACHINE SCREWS AND NUTS.

9

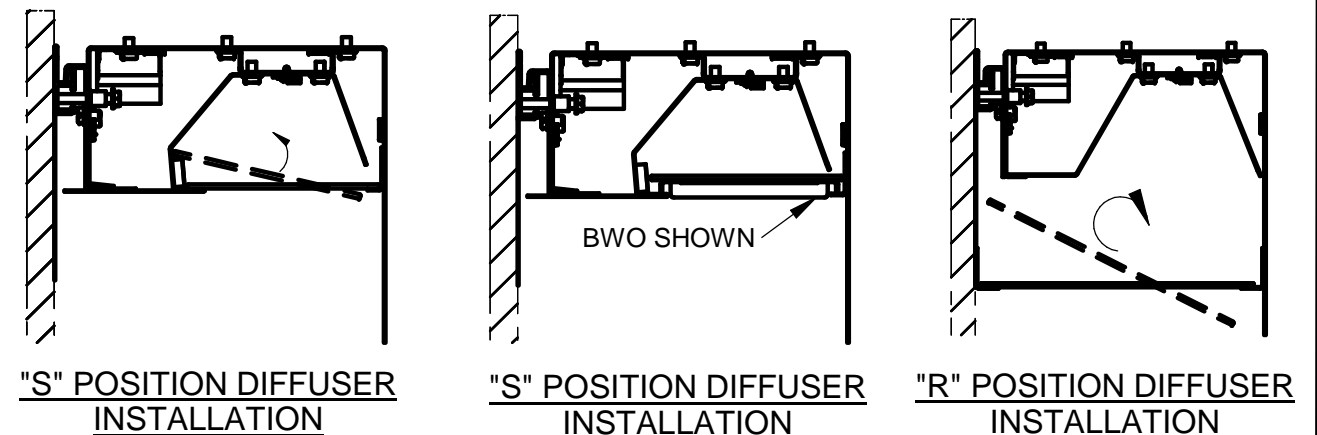

**FOR "S" POSITION:** INSTALL SGL DIFFUSER BY SHIFTING INTO FIXTURE OPENING AND SEATING ON HEMS. IF APPLICABLE, INSTALL BWO (BAFFLE WITH OVERLAY) AFTER INSTALLING SGL DIFFUSER.

**FOR "R" POSITION:** INSTALL SGL DIFFUSER BY SHIFTING ONTO WALL ANGLES. DIFFUSERS ARE SHIPPED SEPARATELY IN 96" LENGTHS AND RUN FULL LENGTH OF FIXTURE OPENING. A SEPARATE 24" PIECE IS PROVIDED FOR FIELD CUTTING TO SUIT ANY EXTRA OPENING IN ROW.



# STRAIGHT EXTENSION SYSTEM CONNECTOR INSTALLATION

1

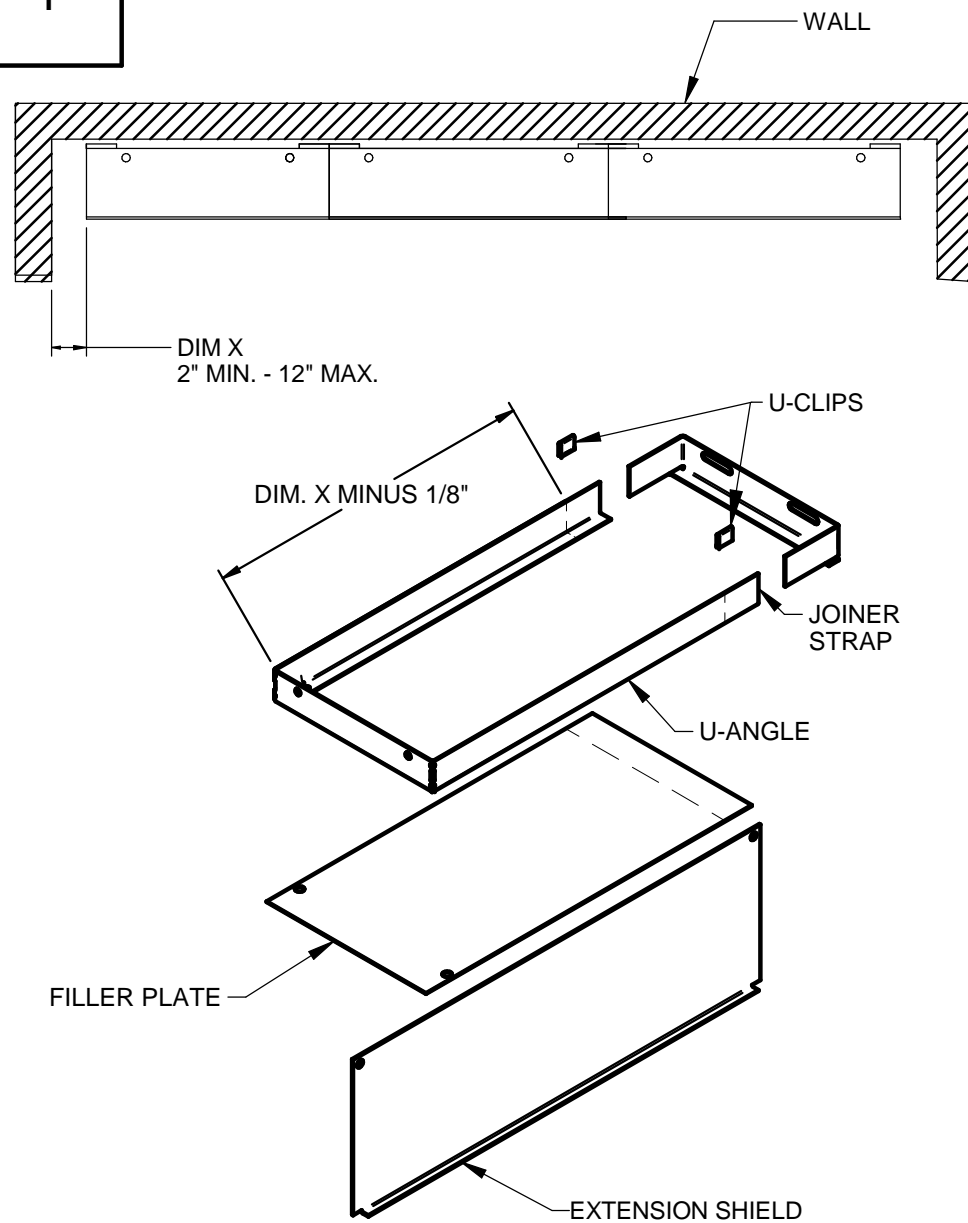

MEASURE DISTANCE FROM END OF FIXTURE TO ADJACENT WALL SURFACE AS SHOWN BY DIM X ABOVE. CUT ENDS OF U-ANGLES AND FILLER PLATES TO DIM X MINUS 1/8" AS SHOWN. INSERT JOINER STRAP INTO ENDS OF TRIMMED U-ANGLE AND SECURE WITH (2) U-CLIPS.

2

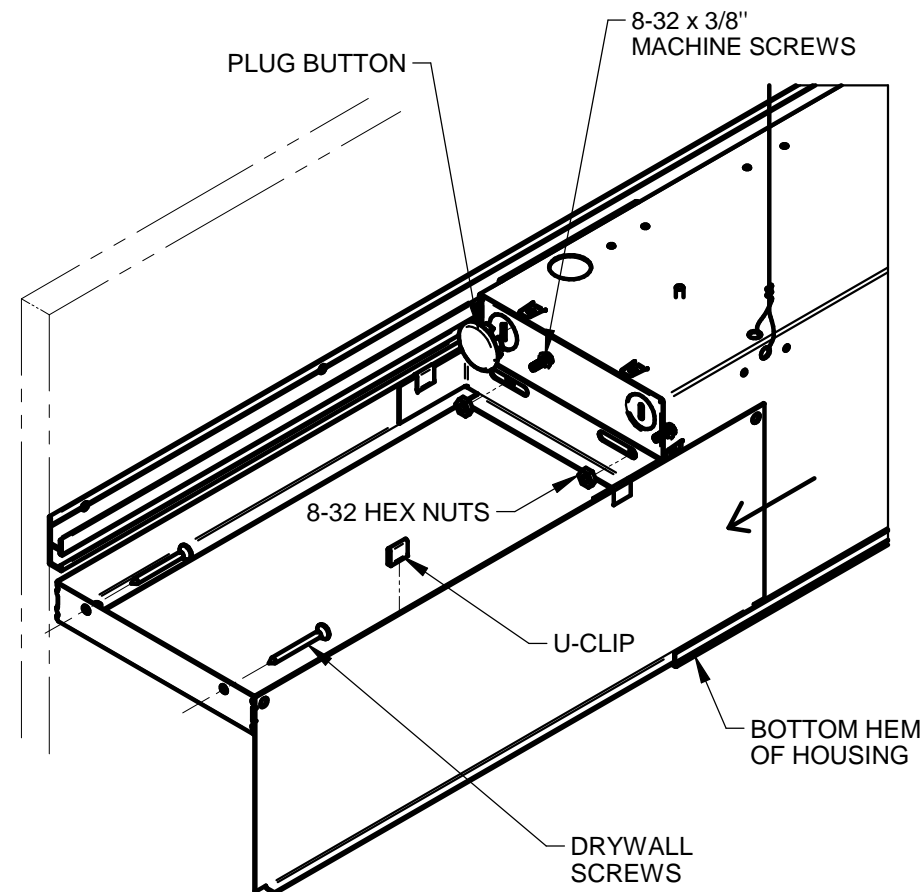

BRING JOINER STRAP/U-ANGLE ASSEMBLY TO CEILING OPENING AND SECURE USING (2) #8-32 X 3/8" LONG SCREWS AND NUTS. ATTACH U-ANGLE TO WALL SURFACE WITH DRYWALL SCREWS. INSERT EXTENSION SHIELD BOTTOM HEM OF HOUSING; SLIDE UP AGAINST WALL AND SECURE SHIELD TO U-ANGLE USING U-CLIP.

3

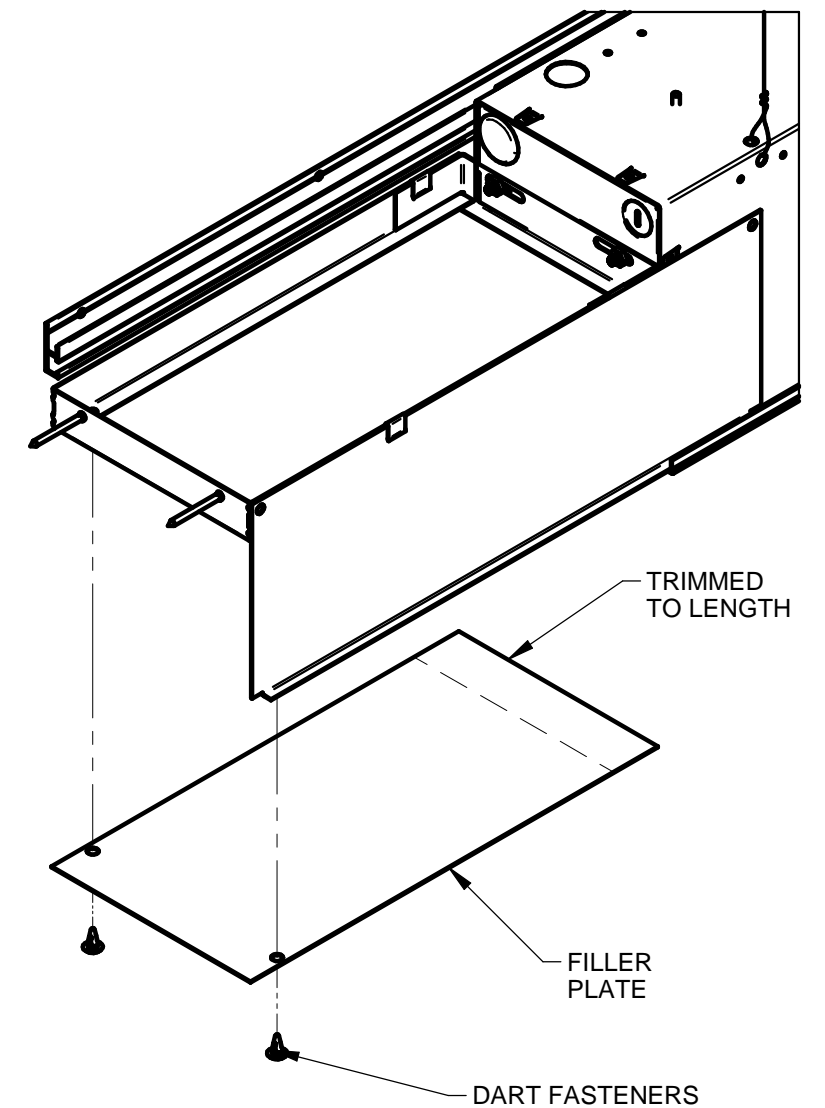

TUCK TRIMMED EDGE OF FILLER PLATE INTO BOTTOM FLANGE OF JOINER STRAP AND SECURE TO U-ANGLE WITH DART FASTENERS. ATTACH PLENUM END CAPS AT END HEADERS (SEE PAGE 8).

# CORNER KIT SYSTEM CONNECTOR INSTALLATION

1

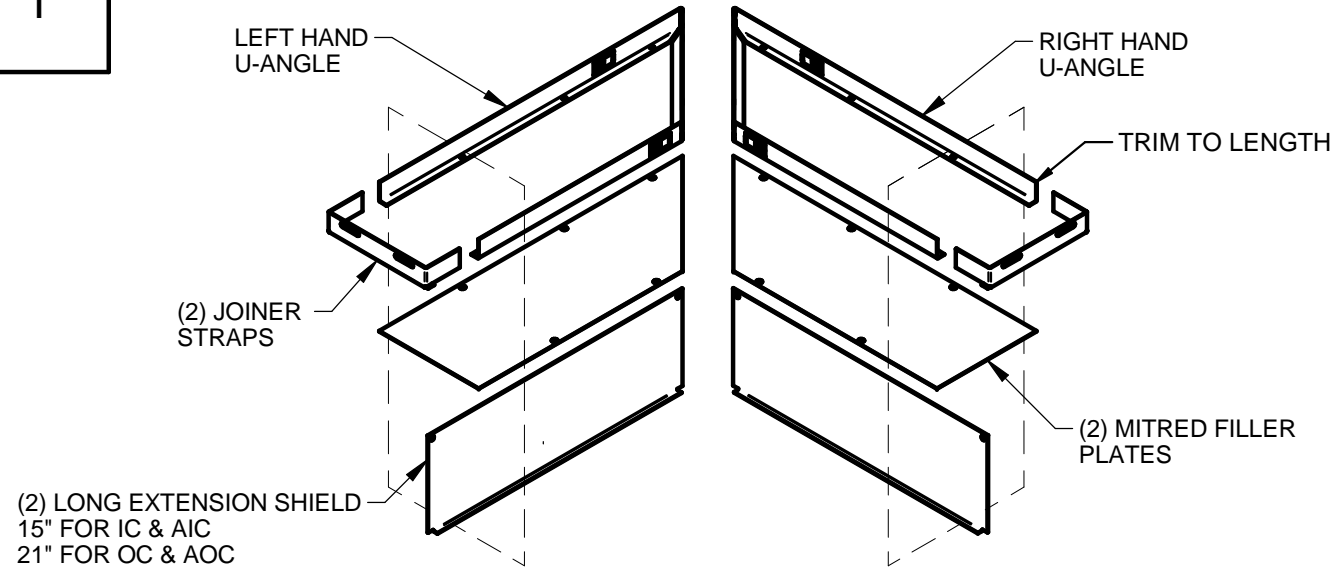

SAWCUT ENDS OF LEFT HAND AND RIGHT HAND MITRED U-ANGLES TO LENGTH AS SHOWN. REFER BACK TO PAGE 4, STEP 2 FOR DIMENSIONS. TRIM OFF SAME AMOUNT ON ENDS OF MITRED FILLER PLATES.

2

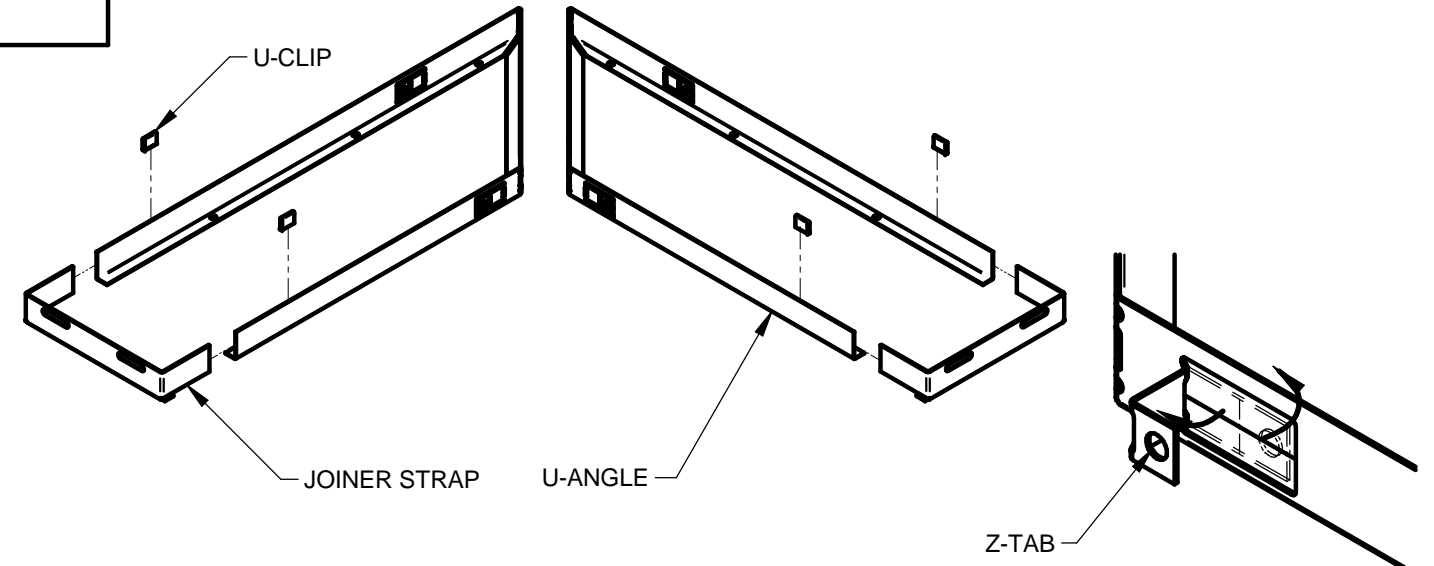

INSERT JOINER STRAP INTO ENDS OF EACH TRIMMED U-ANGLE AND SECURE WITH (2) U-CLIPS AS SHOWN. HAND BEND Z-TAB SUPPORTS IN EACH U-ANGLE OUTWARD TO WALL.

3

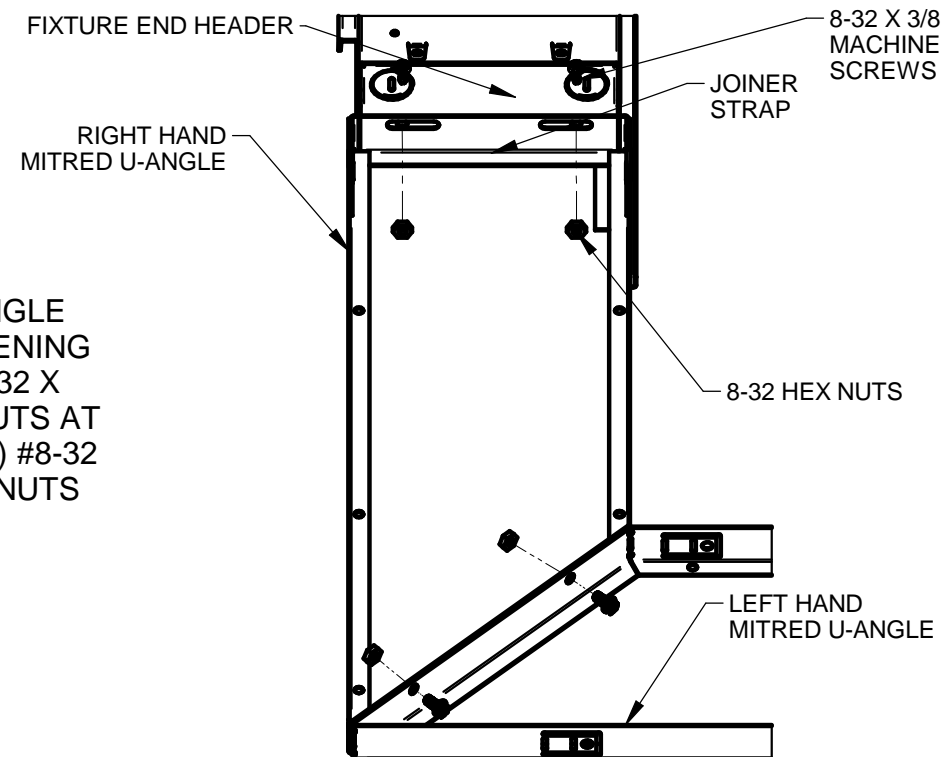

BRING JOINER STRAP/U-ANGLE ASSEMBLY TO CEILING OPENING AND SECURE USING (2) #8-32 X 3/8" LONG SCREWS AND NUTS AT END HEADER. ALSO USE (2) #8-32 X 3/8" LONG SCREWS AND NUTS TO ATTACH U-ANGLES AT MITRED JOINT.

4

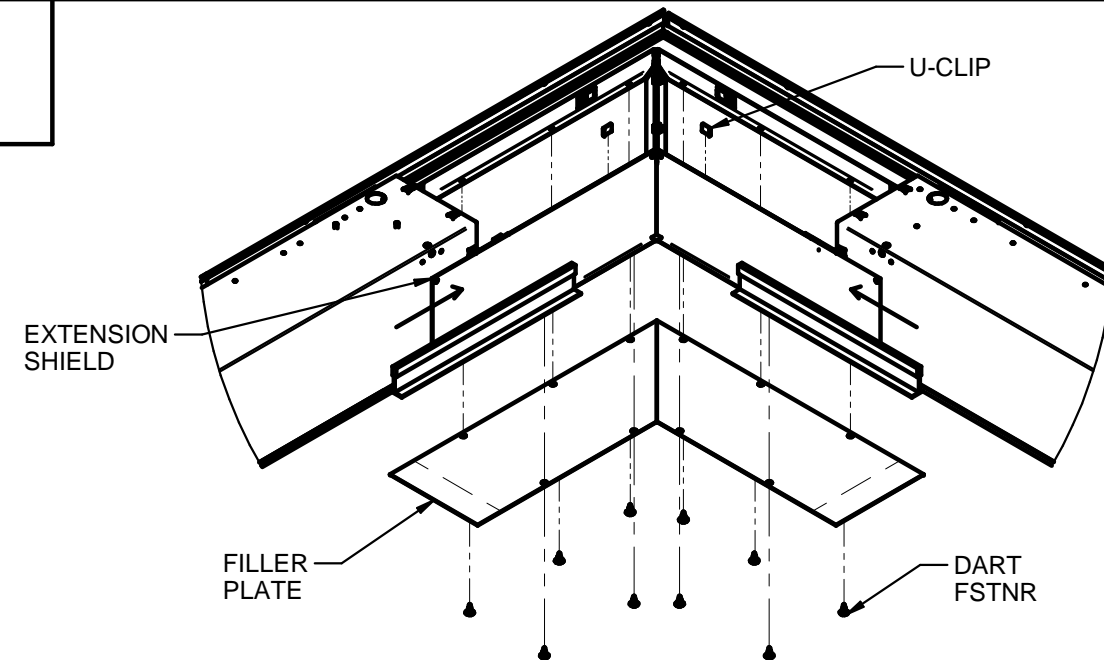

SLIDE EXTENSION SHIELDS UP AGAINST ADJACENT FIXTURE HOUSING AND SECURE WITH (1) U-CLIP. TUCK TRIMMED EDGE OF FILLER PLATES INTO BOTTOM U-ANGLE USING DART FASTENERS AS SHOWN.

**FOR "R" POSITION DIFFUSERS ONLY:**

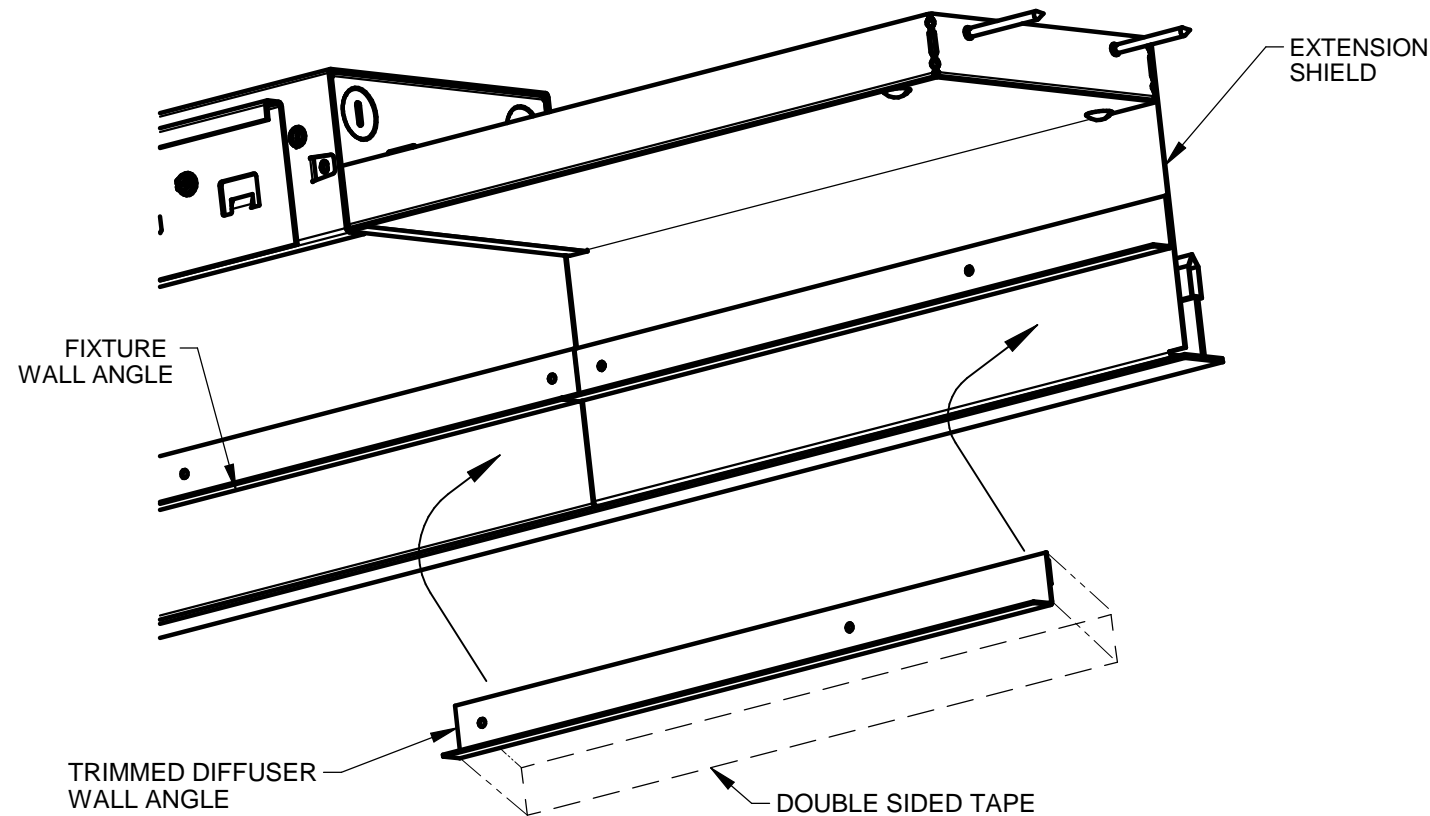

TRIM EXTRA PIECE OF WALL ANGLE AND APPLY DOUBLE SIDED TAPE TO BACK SURFACE. PRESS WALL ANGLE ONTO EXTENSION SHIELD IN LINE WITH WALL ANGLE OF FIXTURE. "R" POSITION LENSES ARE SUPPLIED IN (2) 24" LONG MITRED PIECES PER CORNER. LENSES ARE SAWCUT TO FIT REMAINING OPENING AFTER 96" FIXTURE LENSES ARE INSTALLED.

**PLENUM END CAP INSTALLATION**

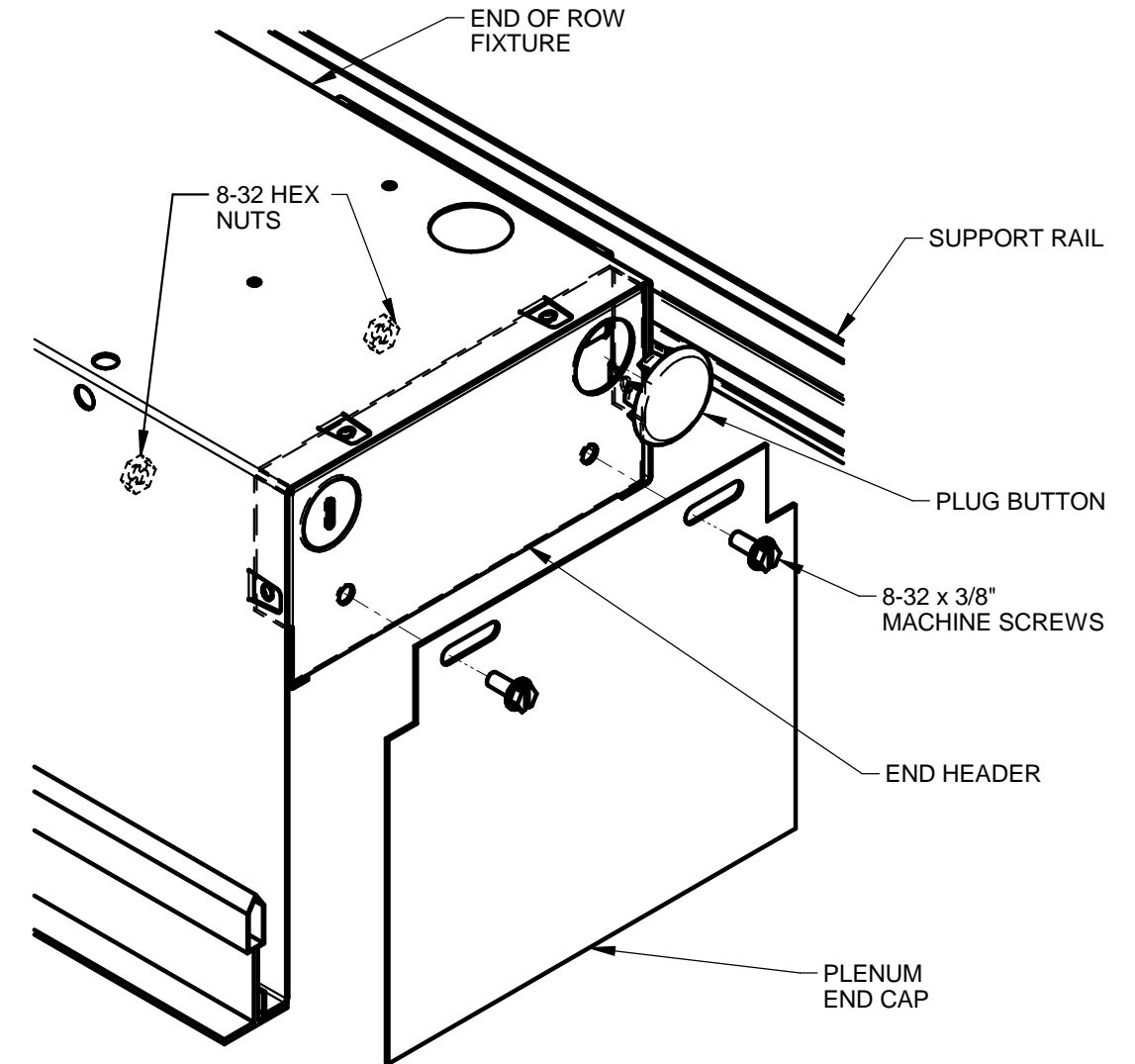

ATTACH PLENUM END CAP TO END HEADER OF END-OF-ROW FIXTURES USING (2) #8-32 X 3/8" LONG MACHINE SCREWS AND NUTS. INSERT PLUG BUTTON INTO OPEN 7/8" HOLE IN END HEADER.