

**GENERAL NOTES: (READ SHEETS COMPLETELY BEFORE STARTING)**

1. LEAVE PROTECTIVE WRAPPING MATERIAL ON FIXTURE (S) UNTIL START OF INSTALLATION TO PROTECT FINISH FROM DAMAGE.
2. FIXTURES ARE SUPPLIED WITH FACTORY-INSTALLED BRANCH CIRCUIT WIRING. REFER TO SUPPLEMENTAL INSTRUCTION SHEET 510401 WHEN MAKING CONNECTIONS.
3. APPROXIMATE WEIGHT OF FIXTURE IS 3.50 LBS PER FOOT OF LENGTH.
4. FEED CORDS ARE FACTORY INSTALLED ON INDIVIDUAL FIXTURES. FOR ROW MOUNTED FIXTURES, FEED CORD IS FACTORY INSTALLED AT END OF ROW LEFT (EORL) FIXTURE ONLY. IF ADDITIONAL FEED CORDS ARE REQUIRED FOR THE ROW, THEY WILL BE SUPPLIED BY LITECONTROL BUT FIELD INSTALLED BY CONTRACTOR.

**TOOLS REQUIRED**

SCREWDRIVER OR 1/4" HEX DRIVER/SOCKET  
9/16" HEX DRIVER/SOCKET OR WRENCH

**SUPPLIED BY INSTALLER**

1

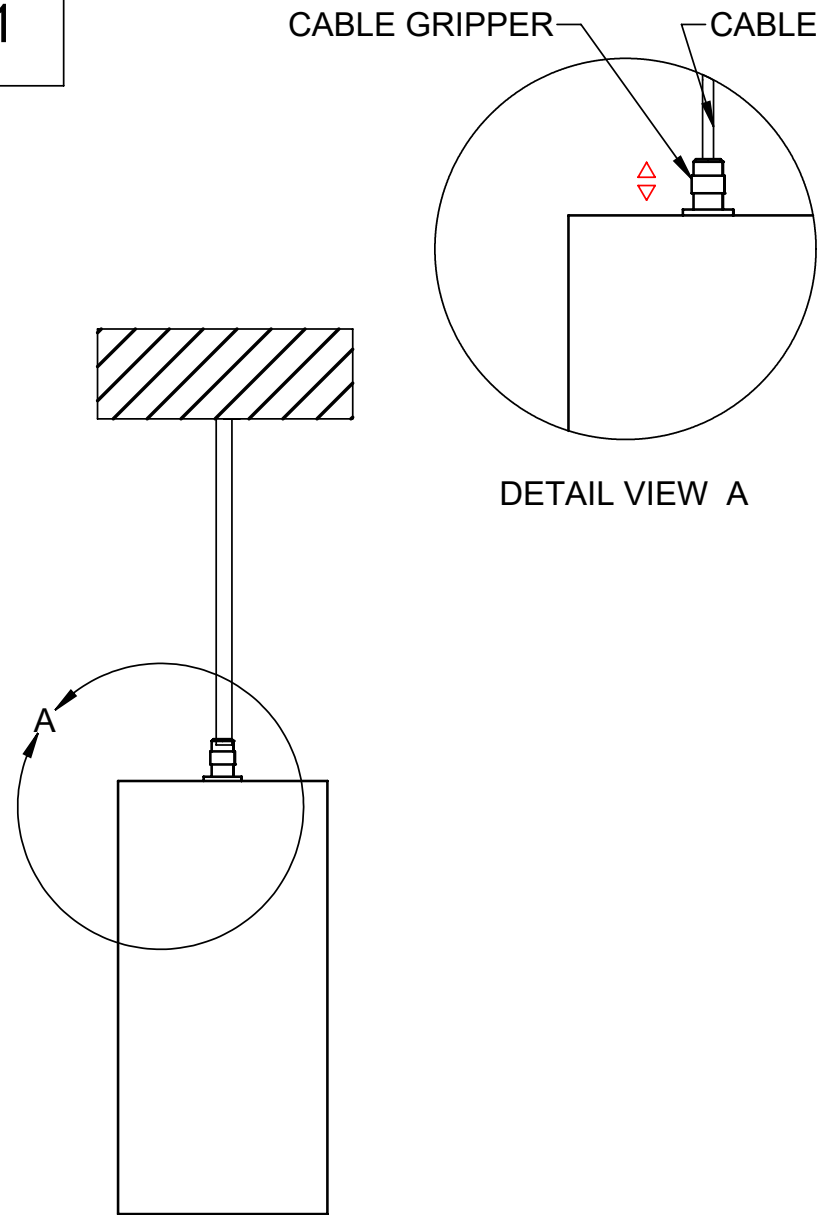

FOR INDIVIDUAL FIXTURE, LIFT FIXTURE UP TO THE AIR CRAFT CABLES AND PASS THE CABLES THROUGH THE GRIPPERS. LEVEL FIXTURE BY ADJUSTING GRIPPER UP OR DOWN. REFER TO CABLE INSTRUCTION SHEET 510541. FOR ROW MOUNTED FIXTURES, PERFORM THIS STEP AND PROCEED TO STEP 2.

2

**END CAP REMOVAL**

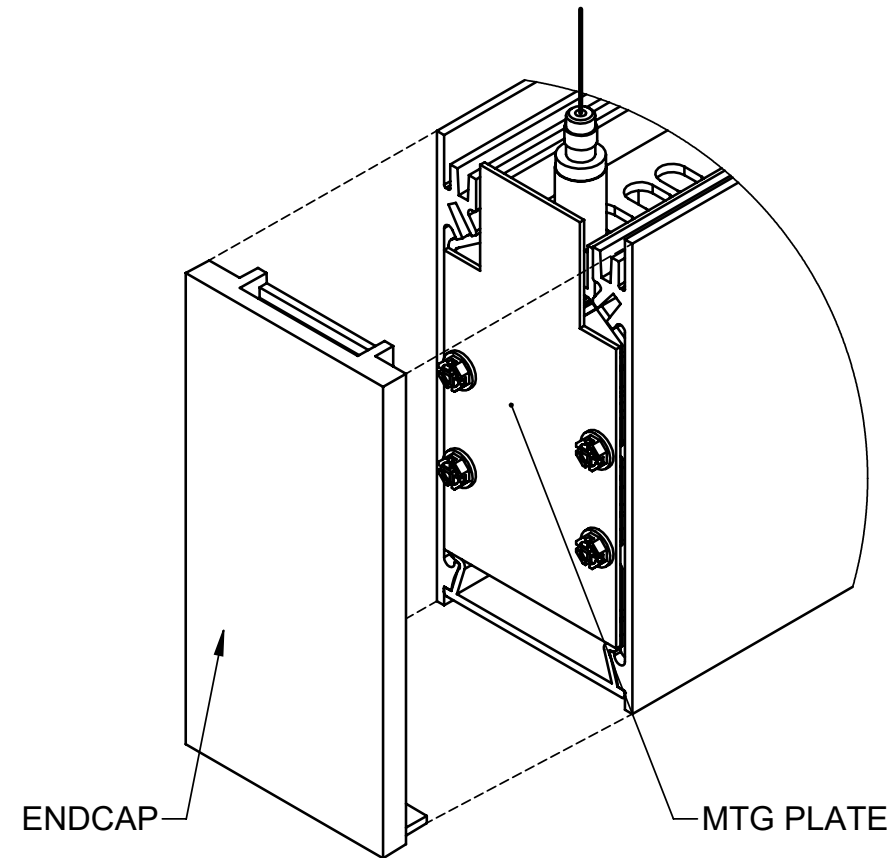

REMOVE THE END CAP ASSEMBLIES BY PULLING END CAP TO DISENGAGE MAGNETS AND LIFT UP TO DISENGAGE FROM TAB ON END CAP PLATE. FOR INDIVIDUAL FIXTURE, DO SO AT BOTH ENDS. FOR ROW, DO SO AT NEAR END OF 1ST FIXTURE AND FAR END OF LAST FIXTURE.

3

**LENS REMOVAL**

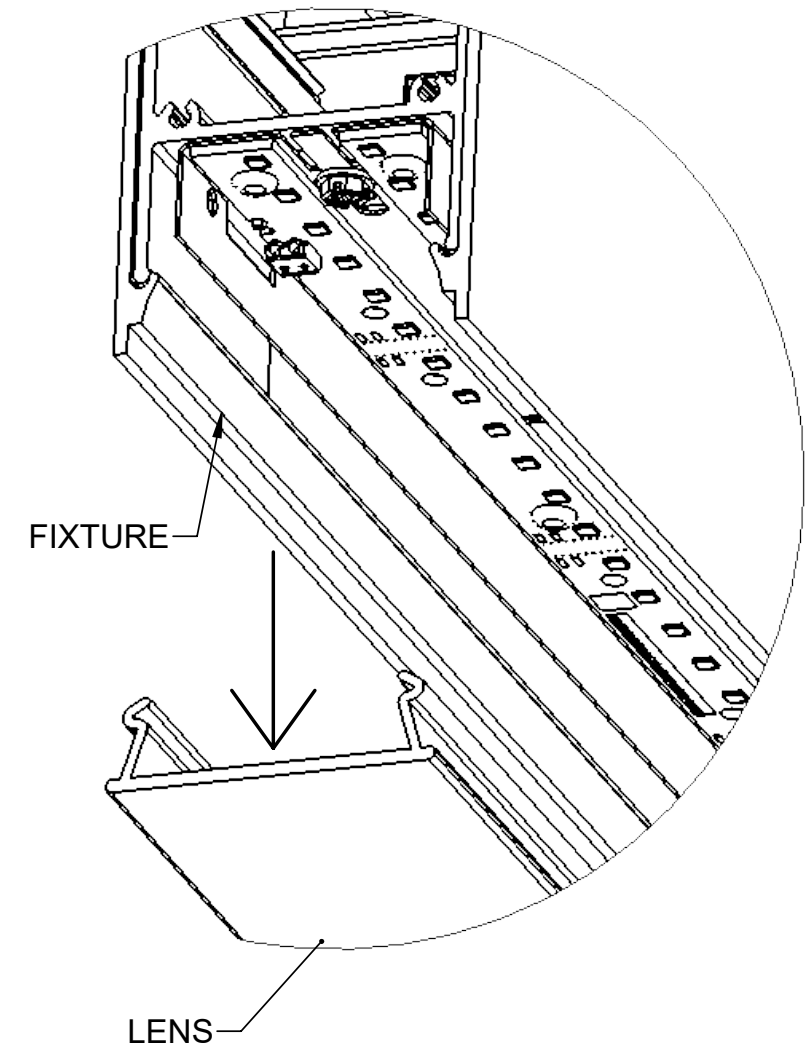

TO REMOVE, PULL LENS DOWN TO DISENGAGE LENS FROM FIXTURE.

**4**

**LED REFL ASSEMBLY REMOVAL**

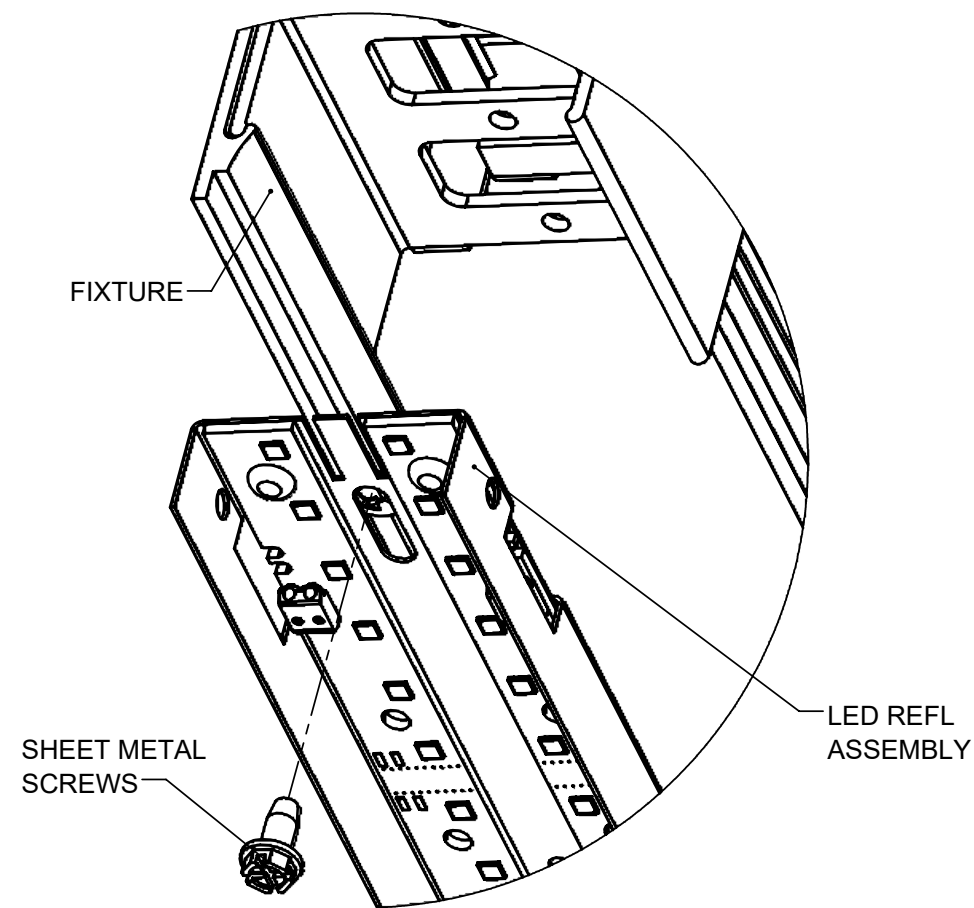

BEFORE REMOVING LED REFL ASSEMBLY SEE STEP 2 AND 3 FOR END CAP AND LENS REMOVAL. TO REMOVE LED REFLECTOR ASSEMBLY: REMOVE THE (2) #8 SHEET METALS SCREWS AS SHOWN. DISCONNECT WIRE NUTS THAT CONNECT LED WIRES TO DRIVER. DISCONNECT SAFETY TETHERS CONNECTED TO THE LED REFLECTOR ASSEMBLY. TO FULLY REMOVE THE LED REFLECTOR ASSEMBLY FROM HOUSING. (TO REPLACE LED REFLECTOR ASSEMBLY REPEAT THE ABOVE STEPS IN REVERSE)

**5**

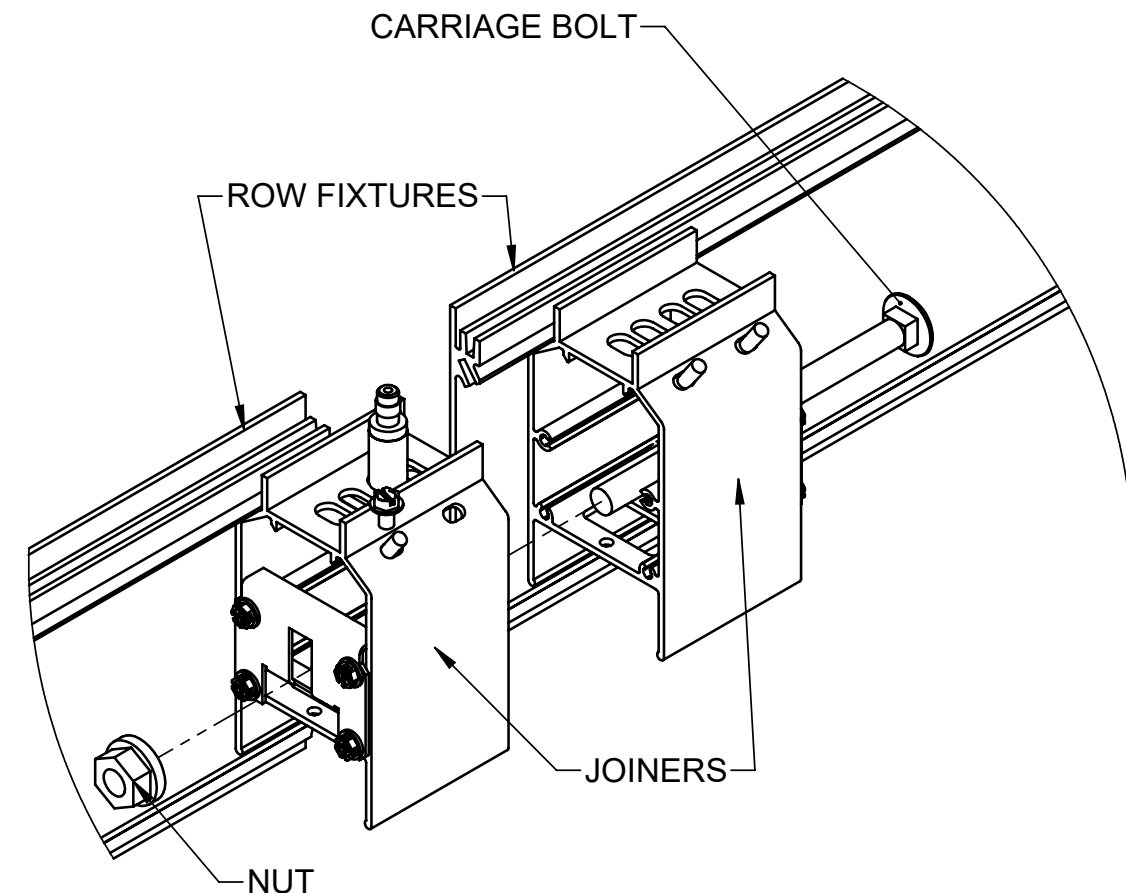

MOUNT THE NEXT FIXTURE IN ROW PER STEP 1. AT FIXTURE JOINT ALIGN AND INSERT EXTRUSION BRACKET OF MALE FIXTURE INTO ADJOINING FIXTURE BEFORE SECURING THE JOINT USING CARRIAGE BOLT AND NUT IN MIDDLE. NOTE STRAIGHTNESS AT JOINTS WHEN TIGHTENING NUT AND BOLT. IF REQUIRED, ADJUST MOUNTING SCREWS TO ENSURE PROPER ROW STRAIGHTNESS AND ALIGNMENT.

**6 END CAP REMOVAL**

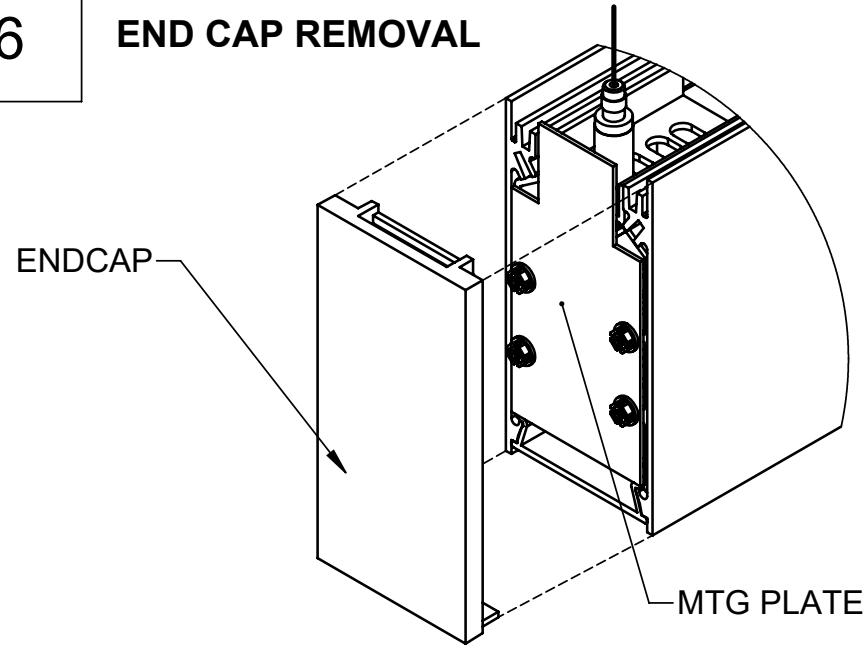

REMOVE THE END CAP ASSEMBLIES BY PULLING END CAP TO DISENGAGE MAGNETS AND LIFT UP TO DISENGAGE FROM TAB ON END CAP PLATE. FOR INDIVIDUAL FIXTURE, DO SO AT BOTH ENDS. FOR ROW, DO SO AT NEAR END OF 1ST FIXTURE AND FAR END OF LAST FIXTURE.

**7 LENS REMOVAL**

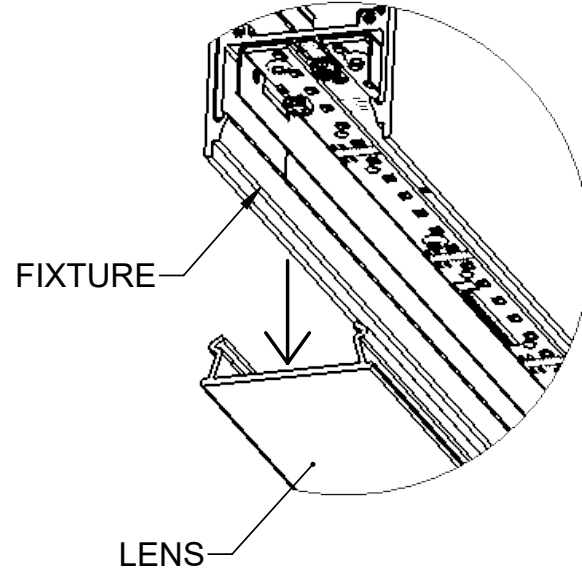

TO REMOVE, PULL LENS DOWN TO DISENGAGE LENS FROM FIXTURE. FOR INDIVIDUAL FIXTURE, REMOVE ONE END CAP PER STEP 6.

**8 LED REFL ASSEMBLY REMOVAL**

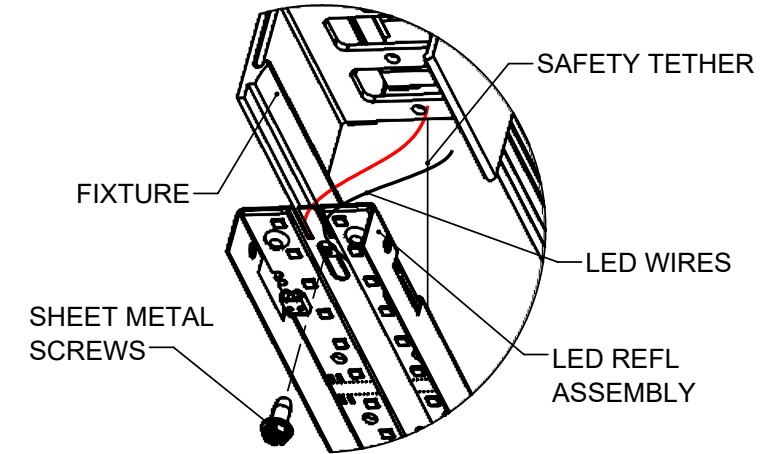

BEFORE REMOVING LED REFL ASSEMBLY SEE STEP 6 AND 7 FOR LENS AND END CAP REMOVAL. TO REMOVE LED TRAY ASSEMBLY: REMOVE THE (2) #8 SHEET METALS SCREWS AS SHOWN. DISCONNECT WIRE NUTS THAT CONNECT LED WIRES TO DRIVER. DISCONNECT SAFETY TETHERS CONNECTED TO THE LED TRAY TO FULLY REMOVE THE LED TRAY ASSEMBLY FROM HOUSING. (TO REPLACE LED TRAY ASSEMBLY REPEAT THE ABOVE STEPS IN REVERSE)

**9 END CAP MTG PLATE REMOVAL**

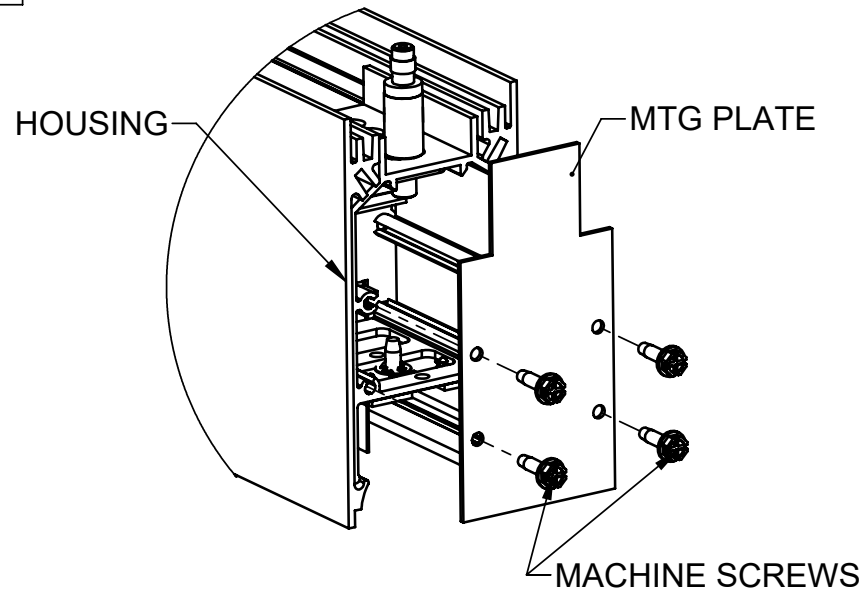

TO REMOVE END CAP MOUNTING PLATE, REMOVE THE 6-32 MACHINE SCREWS SHOWN ABOVE.

**10 GRIPPER REMOVAL**

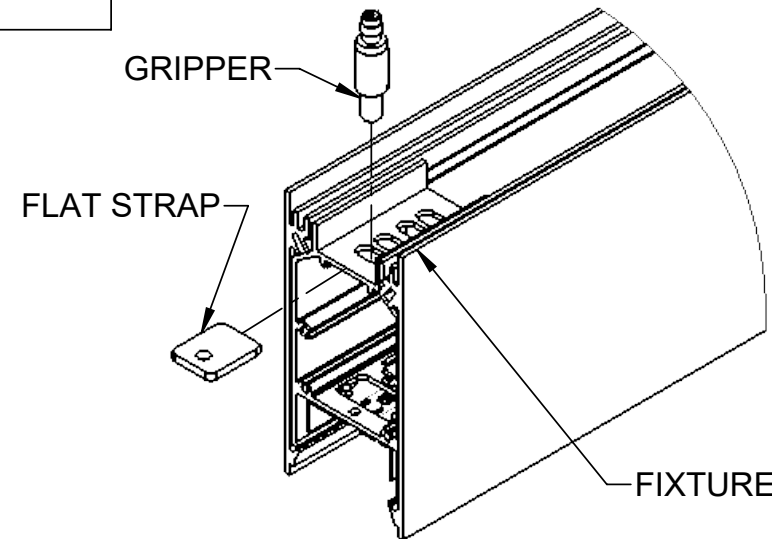

TO REMOVE CABLE GRIPPER, COMPLETELY UN-SCREW CABLE GRIPPER UNTIL BOTTOM THREADS OF CABLE GRIPPER RELEASE FROM FLAT STRAP. SLIDE OUT FLAT STRAP FROM REST AREA ON EXTRUSION TO REMOVE FLAT STRAP. REPEAT FOR ALL CABLE GRIPPERS ON FIXTURE.

**11 DRIVER REMOVAL**

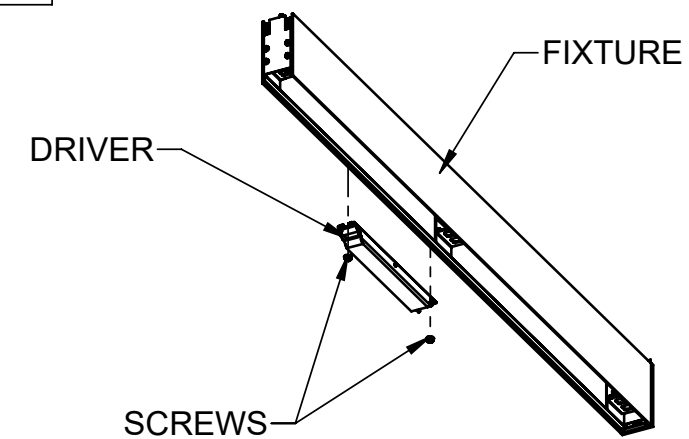

BEFORE REMOVING DRIVER SEE STEPS 7 AND 8 FOR LENS AND LED REFLECTOR ASSEMBLY REMOVAL. REMOVE THE (2) SCREWS AS SHOWN AND REMOVE DRIVER. (TO REPLACE LED REFLECTOR ASSEMBLY REPEAT THE ABOVE STEPS IN REVERSE)