

2L-PT CROSS SECTION

THIS 2" DIMENSION IS CRITICAL TO MAINTAIN THROUGH THE WHOLE FIXTURE LENGTH. THIS IS THE INSIDE DIMENSION OF HOUSING WHERE BOTTOM OF SNAP-FIT LENS SITS

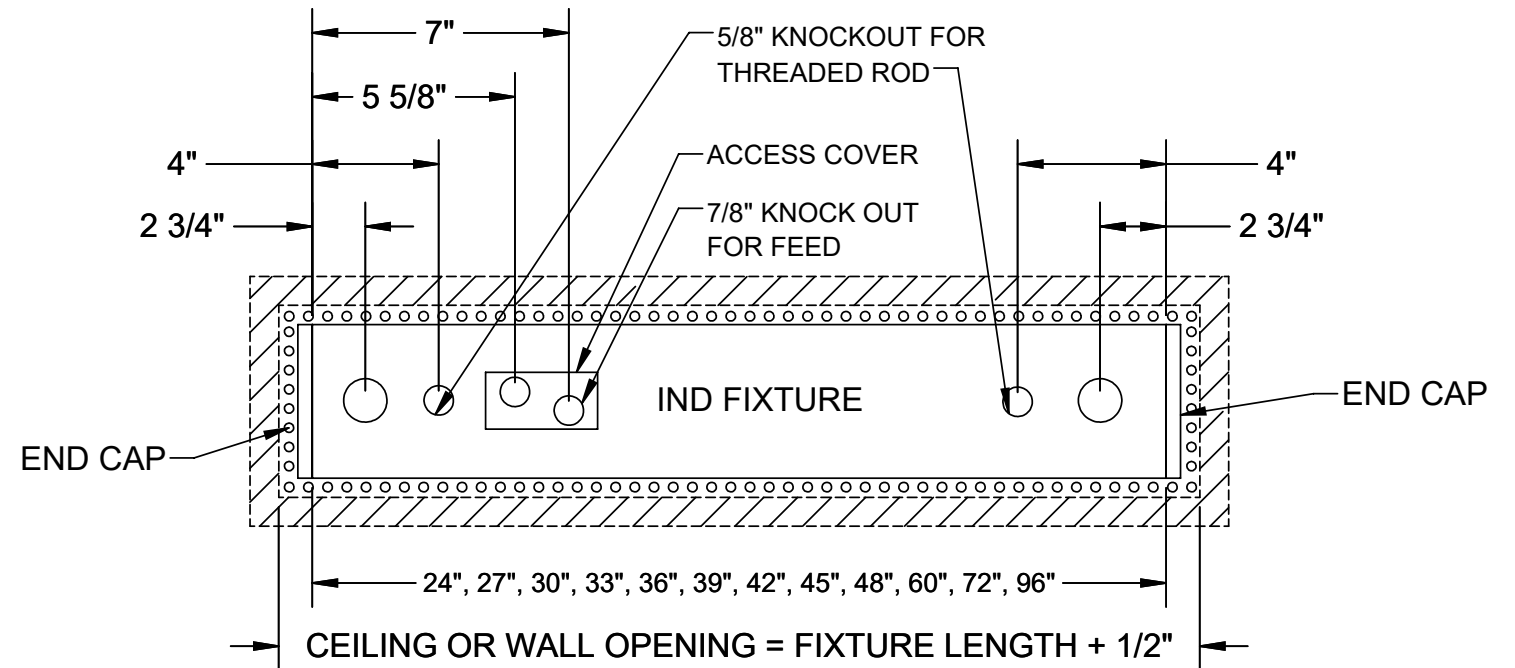

TOP VIEW - INDIVIDUALLY MOUNTED RECESSED FIXTURE

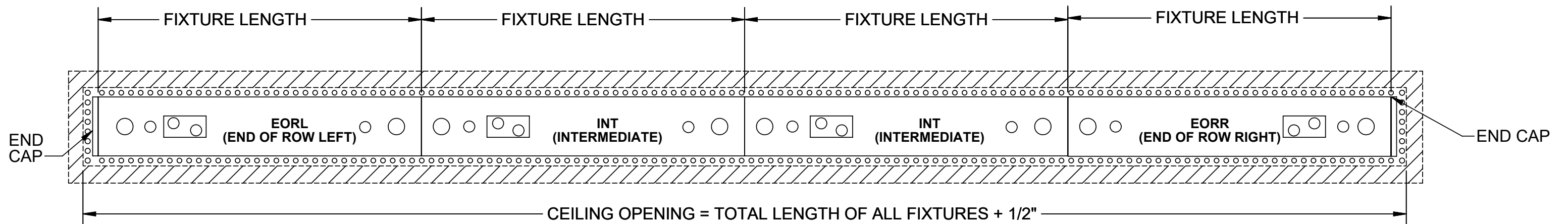

TOP VIEW - ROW MOUNTED RECESSED FIXTURE

GENERAL NOTES: (READ SHEETS COMPLETELY BEFORE STARTING)

1. LEAVE PROTECTIVE WRAPPING ON FIXTURE(S) UNTIL START OF INSTALLATION.
2. FIXTURES ARE PROVIDED WITH FACTORY-INSTALLED BRANCH CIRCUIT WIRING. REFER TO SUPPLEMENTAL INSTRUCTION SHEET 510401 WHEN MAKING CONNECTIONS.
3. FIXTURES ARE MOUNTED IN FRAMED PLASTER DRYWALL CEILING AND SUPPORTED WITH DRYWALL SCREWS. DRYWALL SCREWS ARE INSERTED THROUGH HOLES IN FIXTURE TRIMS AND END CAP TRIMS. SEE STEP-BY-STEP INSTRUCTIONS FOR IMPORTANT DETAILS.
4. FIXTURE WIDTH DIMENSION (SEE CROSS SECTION VIEW) MUST BE MAINTAINED FOR PROPER LENS INSTALLATION.
5. APPROXIMATE WEIGHT OF FIXTURE IS 3.5 LBS PER FOOT OF LENGTH.

TOOLS REQUIRED

SCREWDRIVER OR 1/4" HEX DRIVER/SOCKET

SUPPLIED BY INSTALLER

DRYWALL SCREWS

1

LENS REMOVAL

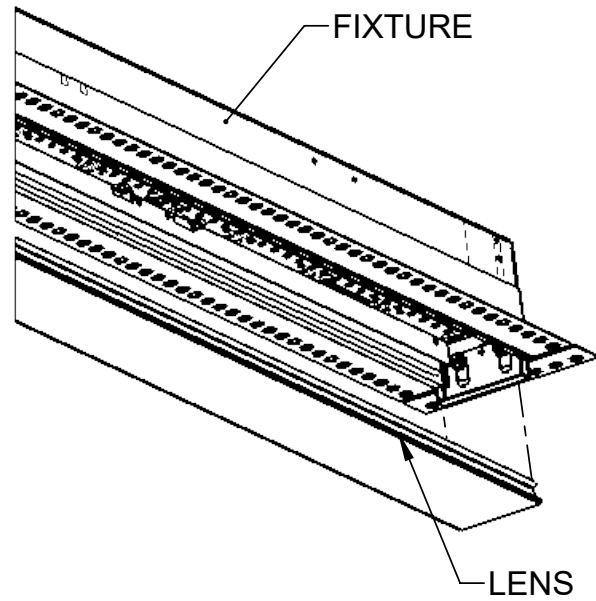

PULL LENS GAP COVER DOWN AND INSERT SCREWDRIVER OR FLAT HEAD PRY TOOL INTO THE END OF THE HOUSING AND PULL DOWN.

2

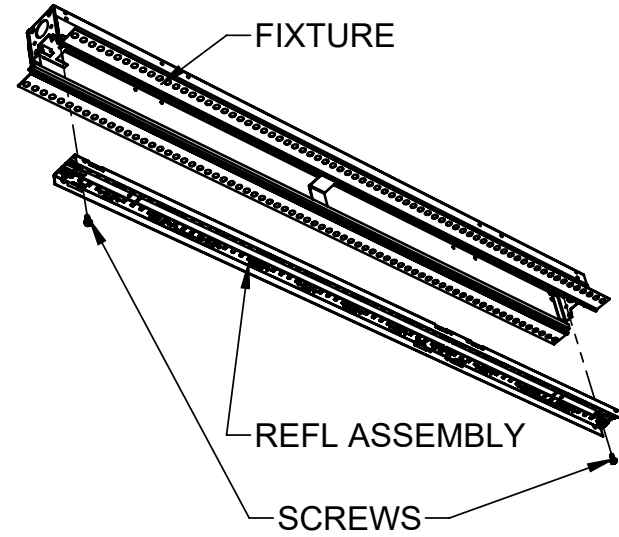

DETACH LED REFLECTOR ASSEMBLY BY REMOVING (2) SCREWS

5

COMPONENTS REMOVED FOR CLARITY

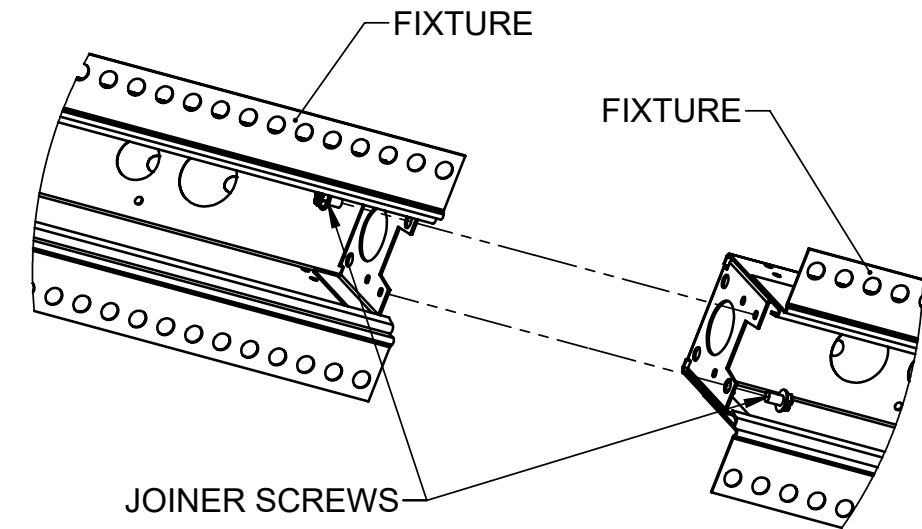

LOOSELY BOLT ADJOINING FIXTURE TO THE PREVIOUS FIXTURE THROUGH BOTH END HEADERS AS SHOWN ABOVE. ALIGN SEAMS AT ROW JOINTS BEFORE TIGHTENING SCREWS.

NOTE: FOLLOW ORIENTATION OF SCREW HEADS SHOWN.

BRANCH CIRCUIT WIRES CAN BE ROUTED THROUGH 7/8" HOLE IN END HEADERS.

3

CEILING CUTOUT

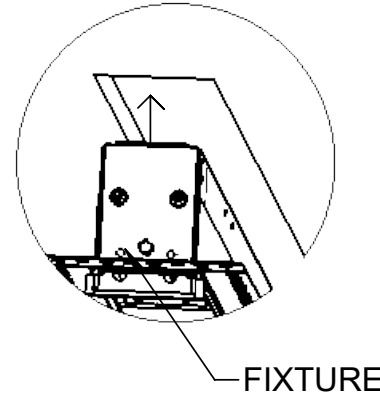

LIFT FIXTURE UP NEAR CEILING OPENING AND BRING ELECTRICAL FEED INTO FIXTURE WIREWAY THROUGH ACCESS COVER.

MAKE ALL ELECTRICAL CONNECTIONS IN FIXTURE WIREWAY AND RE-INSTALL ACCESS COVER PLATE.

4

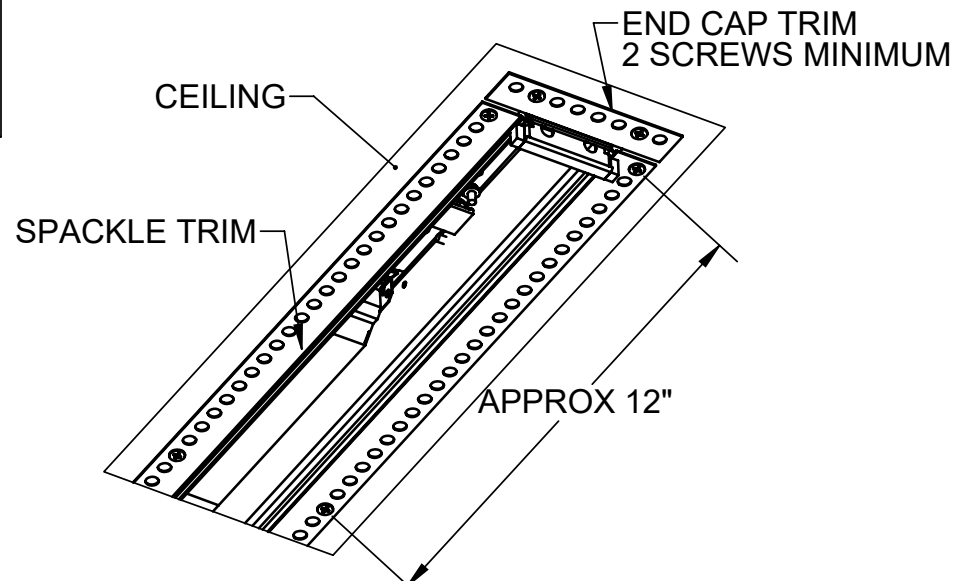

MOUNT FIXTURE(S) TO DRYWALL FRAMED PLASTER CEILING WITH DRYWALL SCREWS (SUPPLIED BY INSTALLER). DRYWALL SCREWS ARE PLACED IN HOLES AT BOTH ENDS OF SPACKLE TRIM AND APPROXIMATELY EVERY 12" ALONG THE LENGTH OF FIXTURE. A MINIMUM OF TWO SCREWS ARE REQUIRED THROUGH SPACKLE END CAP TRIM.

NOTE: KEEP LENS IN PLACE WHILE INSTALLING FIXTURE TO HELP MAINTAIN PROPER FIXTURE WIDTH

6

LENS REMOVAL

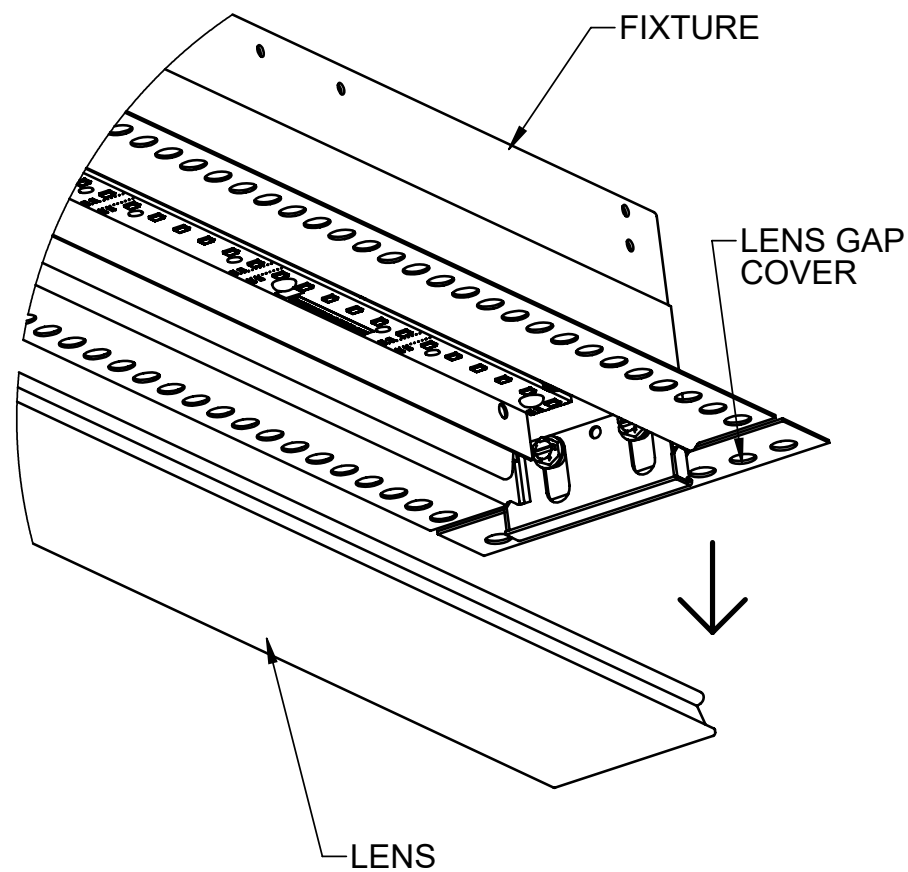

TO REMOVE, PULL LENS GAP COVER DOWN AND INSERT SCREWDRIVER OR FLAT HEAD PRY TOOL INTO THE END OF THE HOUSING AND PULL DOWN.

7

ACCESS PLATE REMOVAL

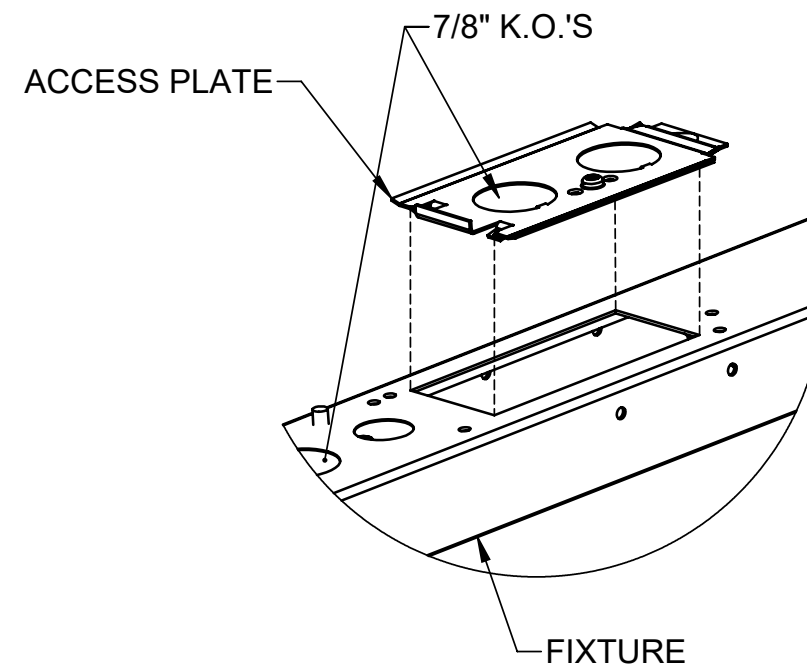

REMOVE ACCESS COVER FROM FIXTURE HOUSING BY SLIDING THE COVER AND SHIFTING IT OUT. REMOVE 7/8" KNOCK-OUT AT DESIRED FEED LOCATION.

8

END CAP REMOVAL

COMPONENTS REMOVED FOR CLARITY

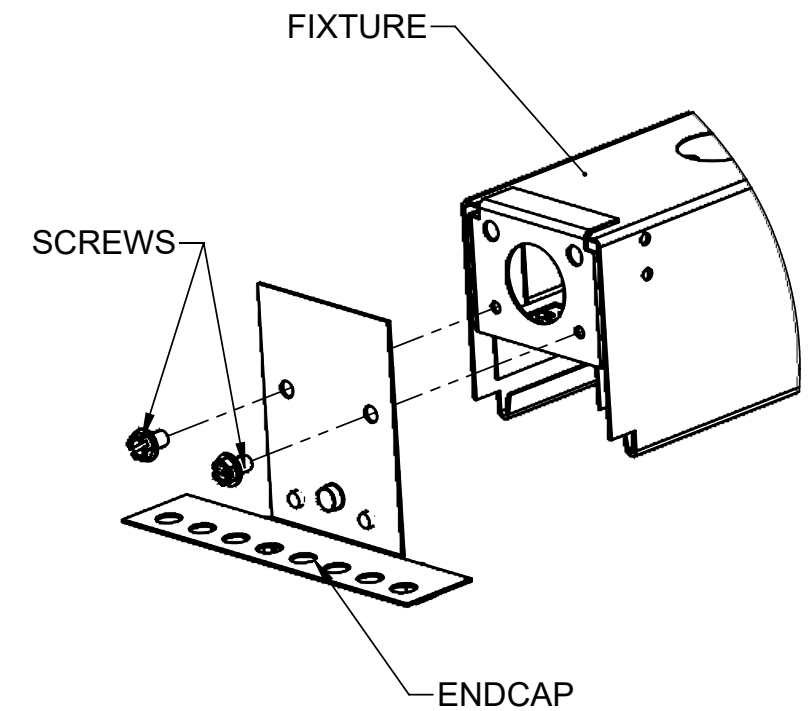

REMOVE THE END CAP ASSEMBLIES BY REMOVING (2) #8 SCREWS AS SHOWN. FOR INDIVIDUAL FIXTURE, DO SO AT BOTH ENDS. FOR ROW, DO SO AT NEAR END OF 1ST FIXTURE AND FAR END OF LAST FIXTURE.

NOTE: SKIP THIS STEP FOR ALL INTERMEDIATE FIXTURES.

9

REFL ASSEMBLY REMOVAL

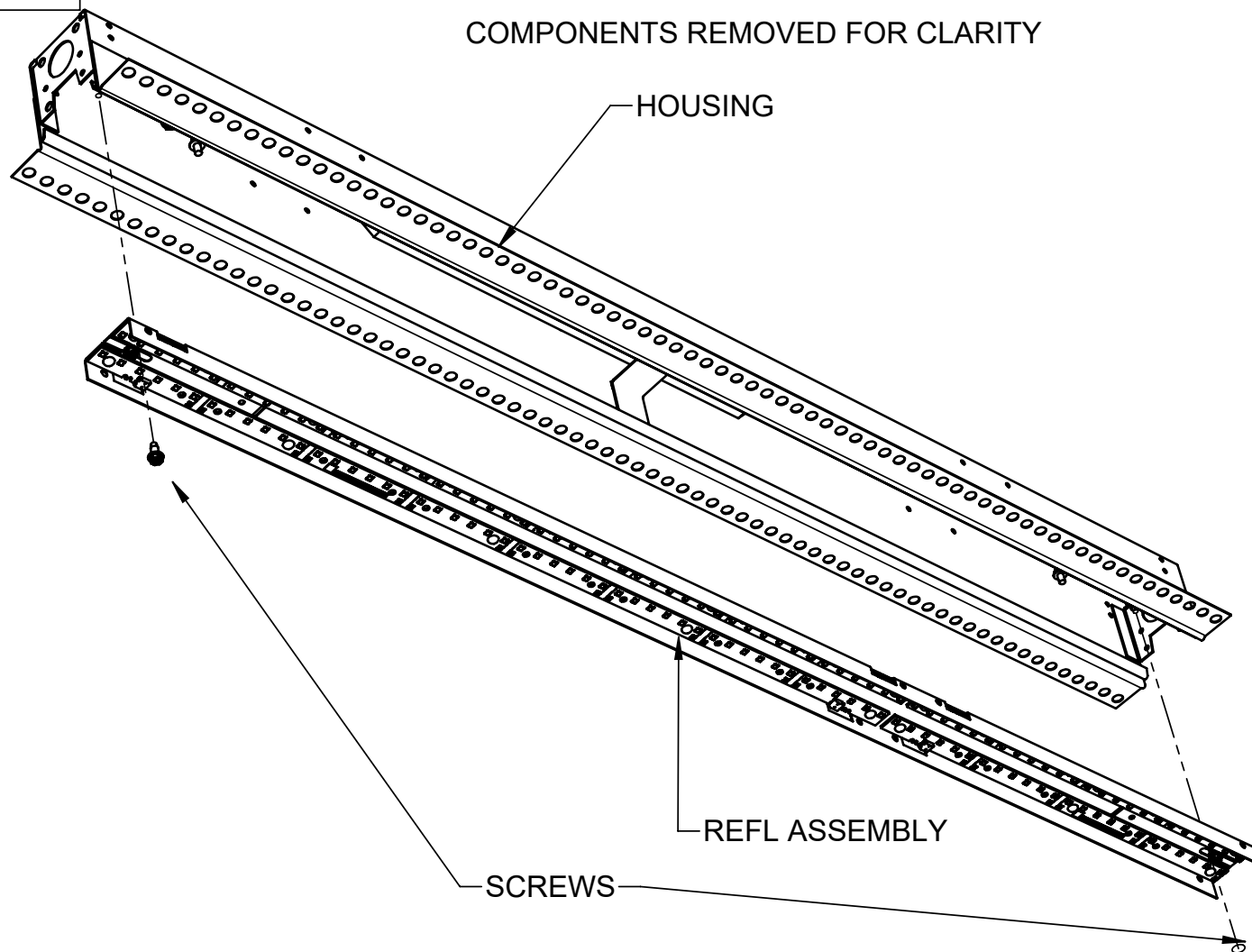

BEFORE REMOVING LED REFLECTOR ASSEMBLY SEE STEP 6 FOR LENS REMOVAL.

TO REMOVE LED REFLECTOR ASSEMBLY:

REMOVE THE (2) #8 SHEET METALS SCREWS AS SHOWN.

DISCONNECT WIRE NUTS THAT CONNECT LED WIRES TO DRIVER.

DISCONNECT SAFETY TETHERS CONNECTED TO THE LED REFLECTOR ASSEMBLY TO FULLY REMOVE THE LED REFLECTOR ASSEMBLY FROM HOUSING.

(TO REPLACE LED REFLECTOR ASSEMBLY REPEAT THE ABOVE STEPS IN REVERSE)

10

DRIVER REMOVAL

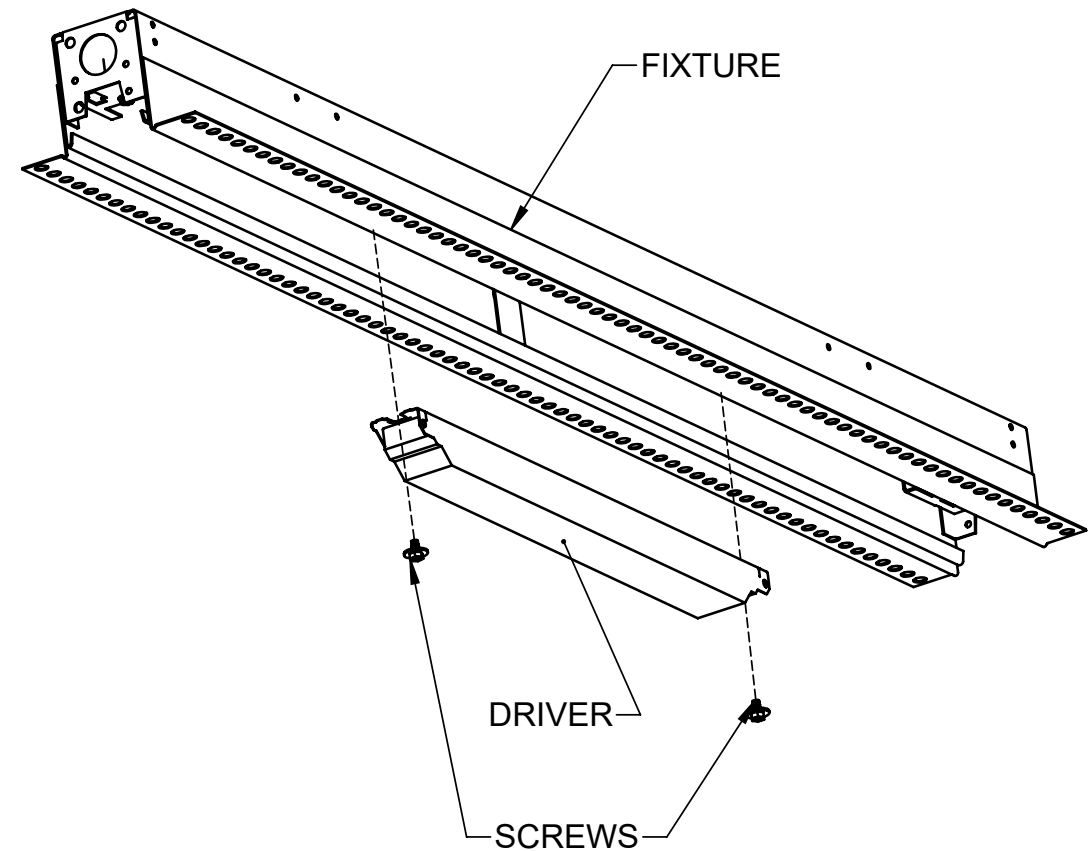

BEFORE REMOVING DRIVER SEE STEPS 6 AND 9 FOR LENS AND LED REFLECTOR ASSEMBLY REMOVAL.

REMOVE THE (2) SCREWS AS SHOWN AND REMOVE DRIVER.

(TO REPLACE LED REFLECTOR ASSEMBLY REPEAT THE ABOVE STEPS IN REVERSE)