

TOP VIEW SURFACE MOUNT

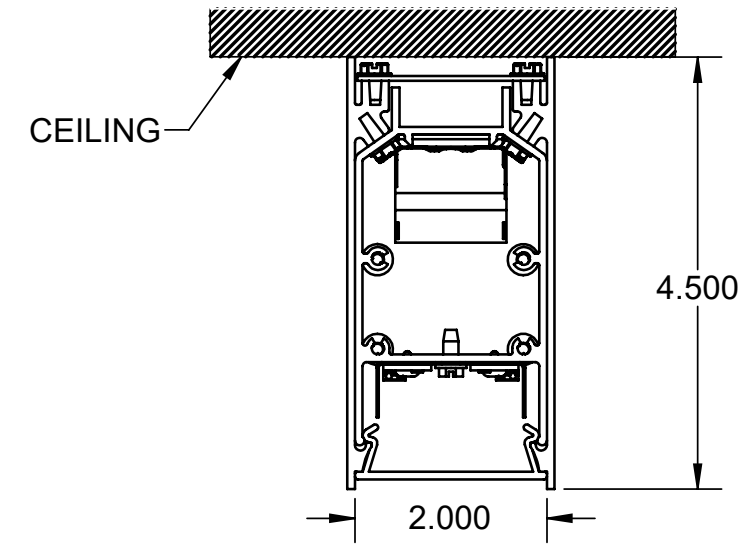

**CROSS SECTION
2L-S-D**

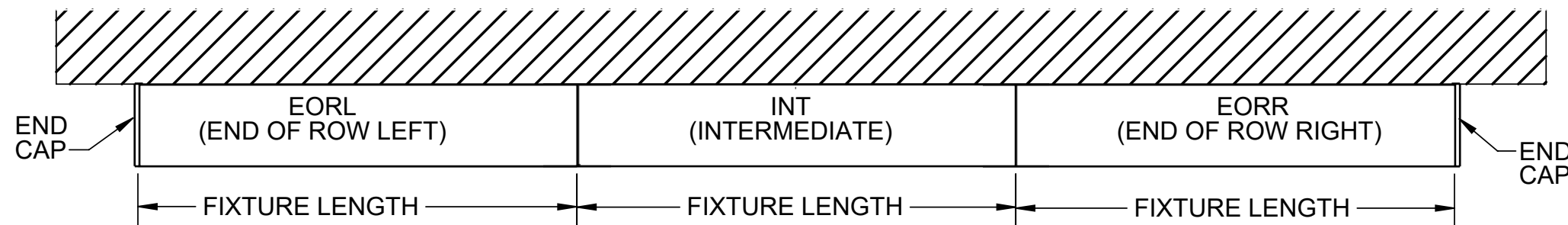

SIDE VIEW SURFACE MOUNT

GENERAL NOTES: (READ SHEETS COMPLETELY BEFORE STARTING)

1. LEAVE PROTECTIVE WRAPPING MATERIAL ON FIXTURES UNTIL START OF INSTALLATION TO PROTECT FINISH FROM DAMAGE.
2. FIXTURES ARE SUPPLIED WITH FACTORY INSTALLED BRANCH CIRCUIT WIRING. REFER TO SUPPLEMENTAL INSTRUCTION SHEET WHEN MAKING CONNECTIONS.
3. APPROXIMATE WEIGHT OF FIXTURE IS 3.50 LBS PER FOOT OF LENGTH.

TOOLS REQUIRED

SCREWDRIVER OR 1/4" HEX DRIVER/SOCKET
7/16" HEX DRIVER/SOCKET OR WRENCH

SUPPLIED BY INSTALLER

ANCHOR MOUNTING SCREWS
FENDER WASHERS

1

SOME COMPONENTS HIDDEN FOR CLAIRITY

BRING POWER
FEED INTO 7/8" KO

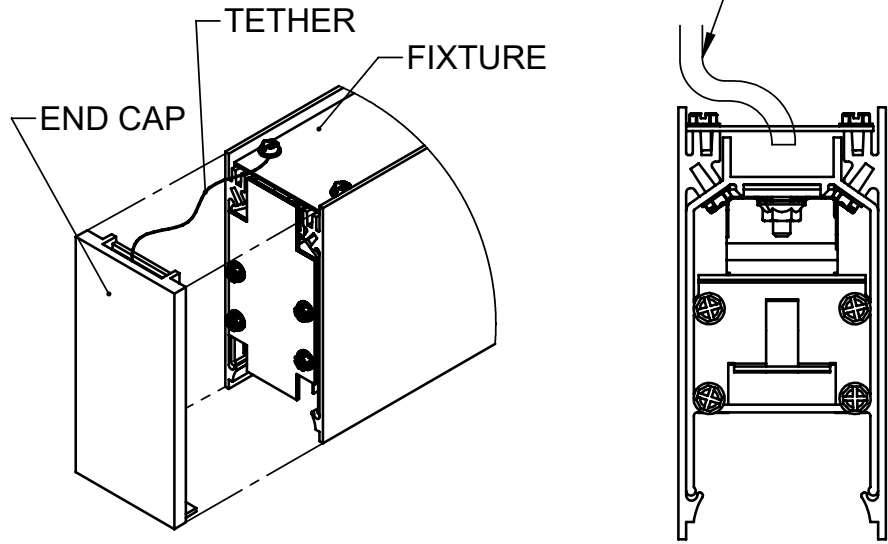

REMOVE THE END CAP ASSEMBLIES BY PULLING END CAP TO DISENGAGE MAGNETS. FOR INDIVIDUAL FIXTURE, DO SO AT BOTH ENDS. FOR ROW, DO SO AT NEAR END OF 1ST FIXTURE AND FAR END OF LAST FIXTURE.

2

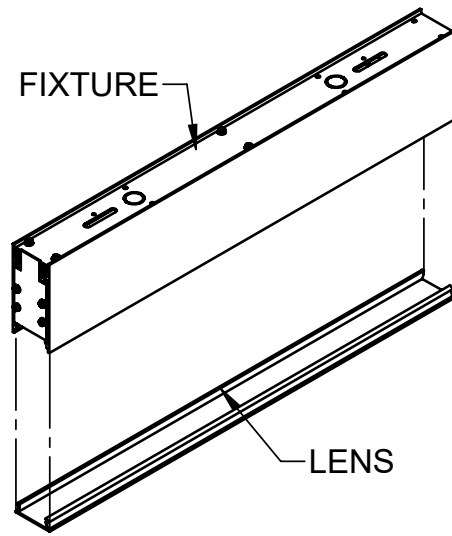

TO REMOVE LENS, PULL LENS DOWN TO DISENGAGE LENS FROM FIXTURE. FOR INDIVIDUAL FIXTURE, REMOVE ONE END CAP PER STEP 1.

3

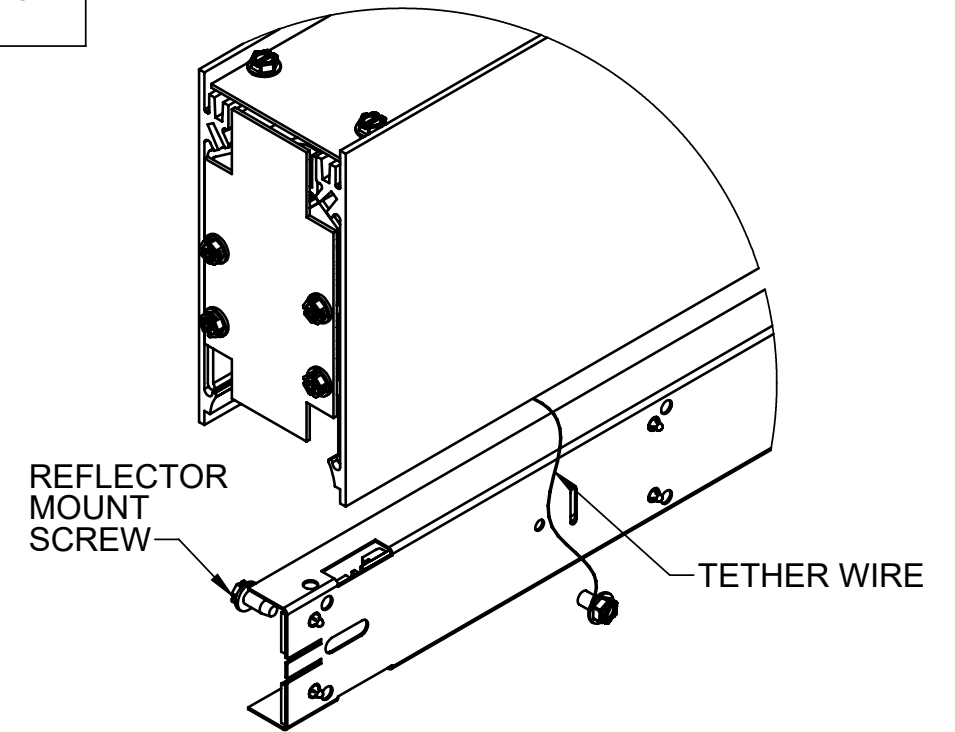

REMOVE REFLECTOR ASSEMBLY AND LET REFLECTOR ASSEMBLY HANG ON TETHERS.

4

SOME COMPONENTS HIDDEN FOR CLAIRITY

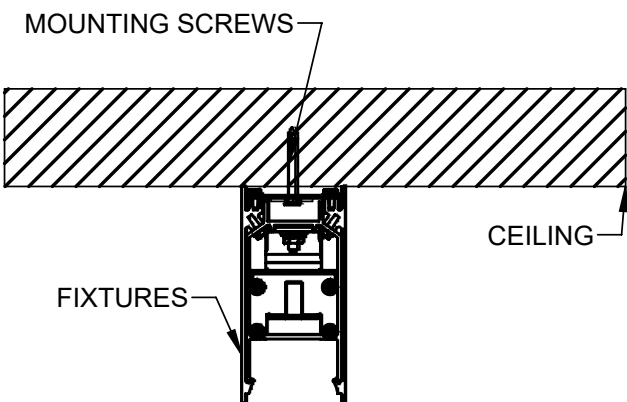

LIFT FIXTURE UP NEAR CEILING . BRING ELECTRICAL FEED THRU 7/8" HOLE AND INTO FIXTURE WIREWAY.
RAISE 1ST FIXTURE FLUSH TO CEILING. SECURE WITH (2) ANCHOR SCREWS AND WASHERS. (SUPPLIED BY INSTALLER) THROUGH MOUNTING SLOTS INTO CEILING STRUCTURE.

5

ROW MOUNT ONLY
SOME COMPONENTS HIDDEN FOR CLAIRITY

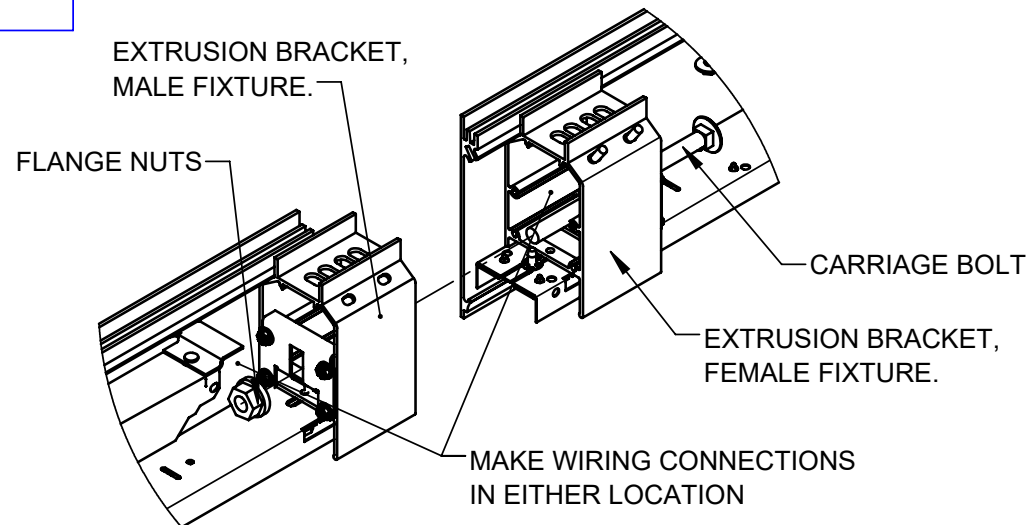

REPEAT STEPS 1-4 FOR ALL INTERMEDIATE FIXTURES. RAISE INT (OR END OF ROW FEMALE) FIXTURES UP AND SLIDE ONTO PROTRUDING BRACKET. INSTALL 5/16-18 X 4.5" CARRIAGE BOLT TO SECURE FIXTURES TOGETHER. ATTACH 5/16-18 FLANGE NUT ON OTHER SIDE OF JOINT AS SHOWN. ALIGN SEAMS BEFORE FULLY TIGHTENING NUT. TIGHTEN ANCHOR SCREWS FROM STEP 4.

6

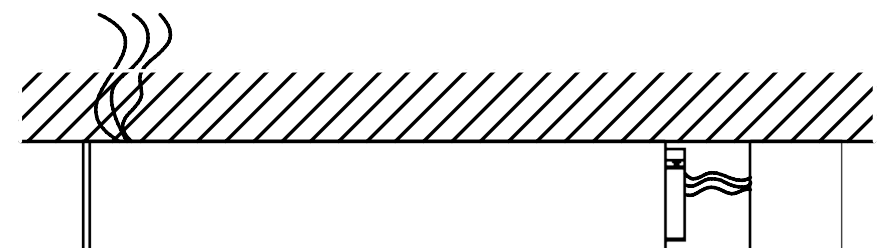

MAKE ELECTRICAL CONNECTIONS IN FIXTURE WIREWAY. IF INSTALLING ROW OF FIXTURES, ELECTRICAL FEED CAN BE AT ANY 7/8" HOLE LOCATION. BRANCH CIRCUIT WIRES CAN BE BROUGHT THROUGH EACH ROW JOINT.

7

LENS REMOVAL

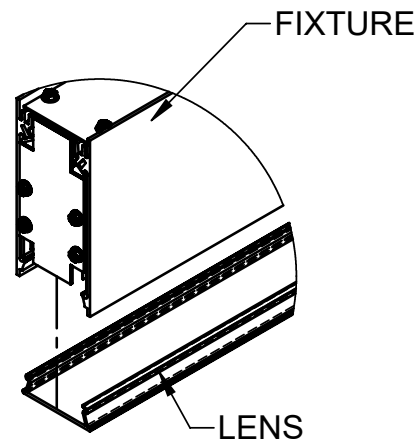

TO REMOVE, PULL LENS DOWN TO DISENGAGE LENS FROM FIXTURE FOR INDIVIDUAL FIXTURE, REMOVE ONE END CAP PER STEP 1.

8

END CAP MTG PLATE REMOVAL

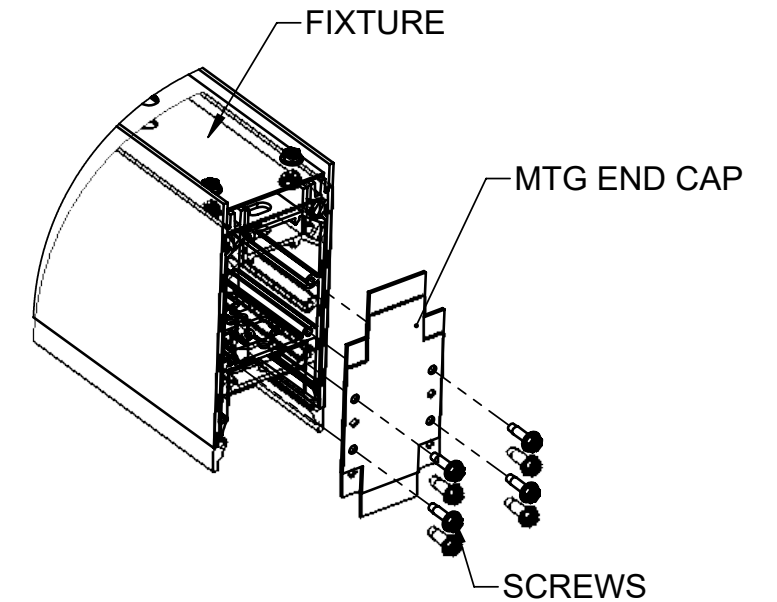

TO REMOVE END CAP MOUNTING PLATE REMOVE THE 6-32 MACHINE SCREWS SHOWN ABOVE.

9

LED REFLECTOR ASSEMBLY REMOVAL

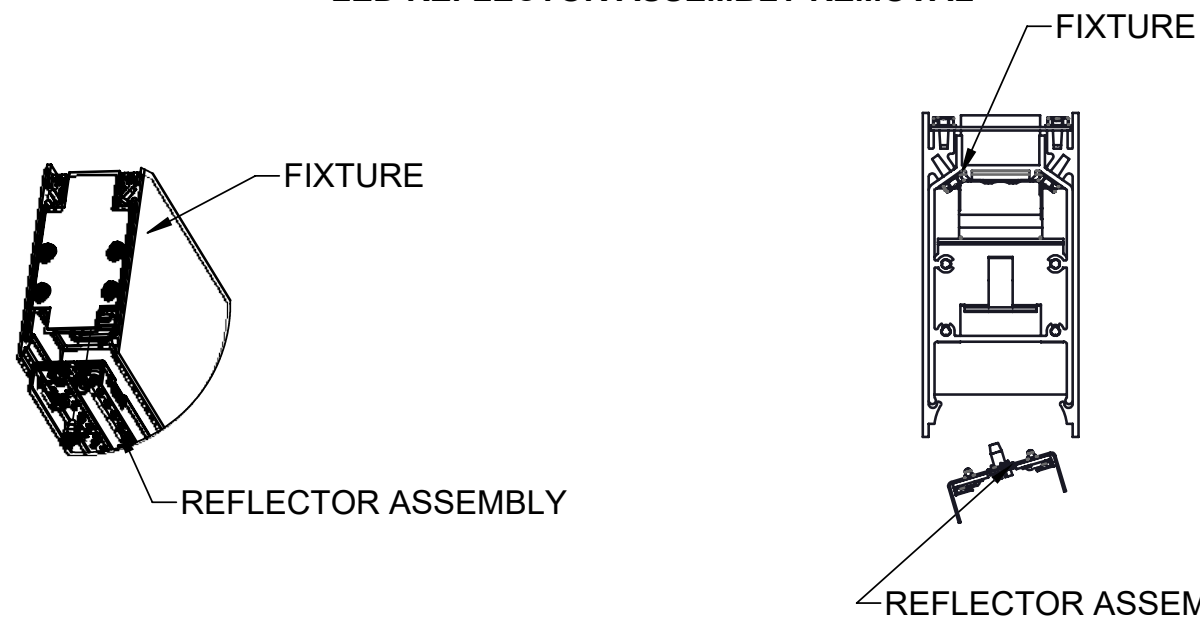

BEFORE REMOVING LED REFLECTOR ASSEMBLY SEE STEP 7 FOR LENS REMOVAL.
 TO REMOVE LED REFLECTOR ASSEMBLY:
 REMOVE THE (2) #8 SHEET METALS SCREWS AS SHOWN.
 DISCONNECT WIRE NUTS THAT CONNECT LED WIRES TO DRIVER.
 DISCONNECT SAFETY TETHERS CONNECTED TO THE LED REFLECTOR ASSEMBLY.

10

DRIVER REMOVAL

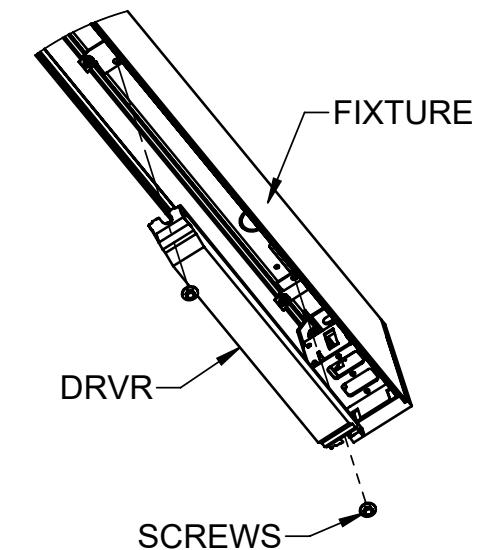

BEFORE REMOVING DRIVER SEE STEPS 7 AND 9 FOR LENS AND LED REFL REMOVAL.
 REMOVE THE (2) SCREWS AS SHOWN AND REMOVE DRIVER.