

**BOTTOM VIEW - RECESSED DRYWALL CORNER FIXTURE**

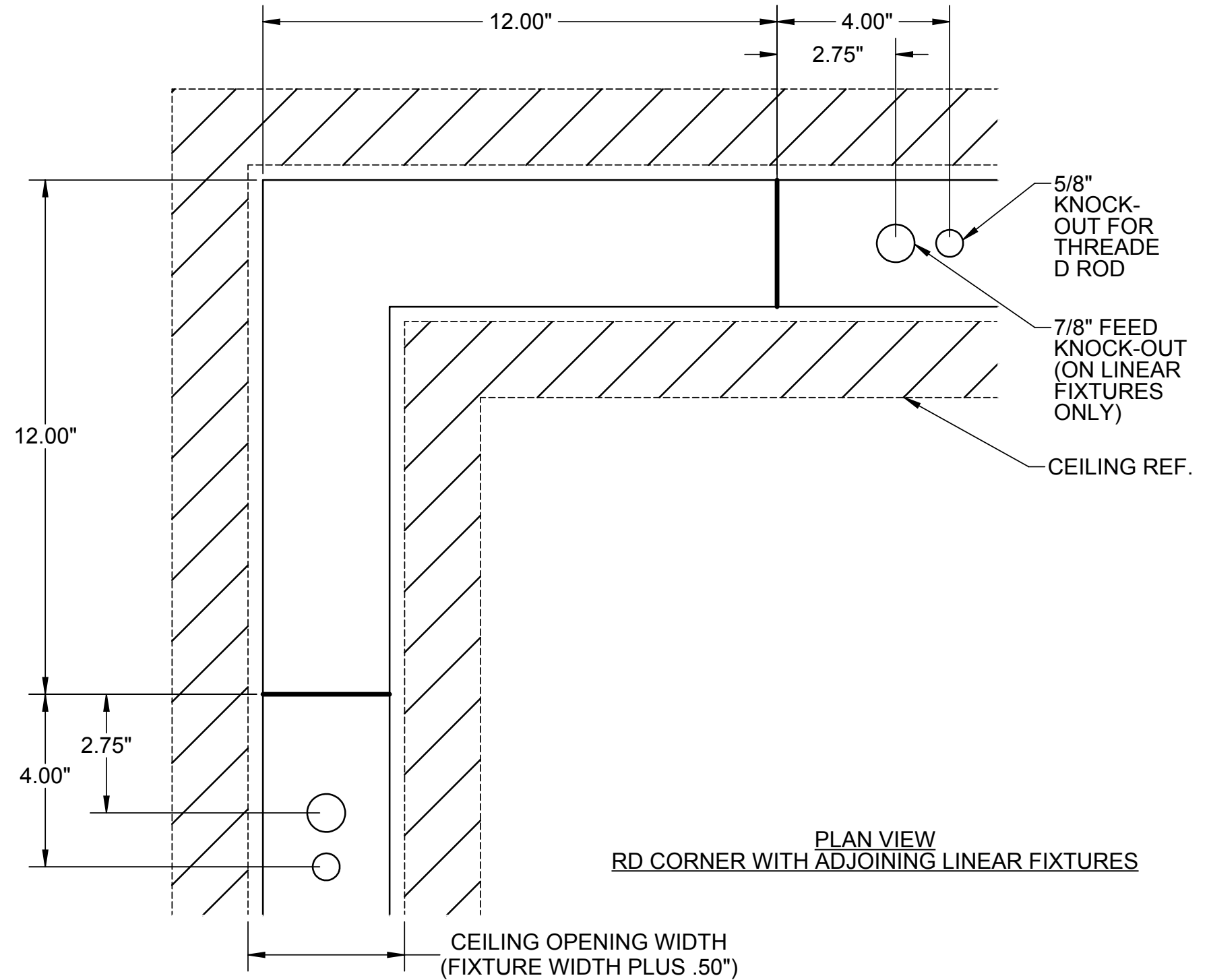

**PLAN VIEW  
RD CORNER WITH ADJOINING LINEAR FIXTURES**

**GENERAL NOTES: (READ SHEETS COMPLETELY BEFORE STARTING)**

- 1. USE THIS INSTRUCTION SHEET IN CONJUNCTION WITH INSTRUCTION SHEET 510639.**
2. LEAVE PROTECTIVE WRAPPING ON FIXTURE(S) UNTIL START OF INSTALLATION TO PROTECT FINISH FROM DAMAGE.
3. FIXTURES ARE SUPPLIED WITH FACTORY-INSTALLED BRANCH CIRCUIT WIRING. REFER TO SUPPLEMENTAL INSTRUCTION SHEET WHEN MAKING CONNECTIONS.
4. FIXTURES ARE MOUNTED IN A DRYWALL CEILING AND SUPPORTED WITH (2) 1/4-20 THREADED RODS OR EQUIVALENT ATTACHED TO OVERHEAD STRUCTURE SUPPLIED BY INSTALLER.

**TOOLS REQUIRED**

- SCREWDRIVER/DRILL
- 11/32" NUT DRIVER

**SUPPLIED BY INSTALLER**

1

INSTALL THE TWO LINEAR FIXTURES ADJACENT TO THE CORNER PER INSTRUCTION SHEET 510639. ALSO REFER TO DIMENSIONS SHOWN IN PLAN VIEW ON PAGE 1.

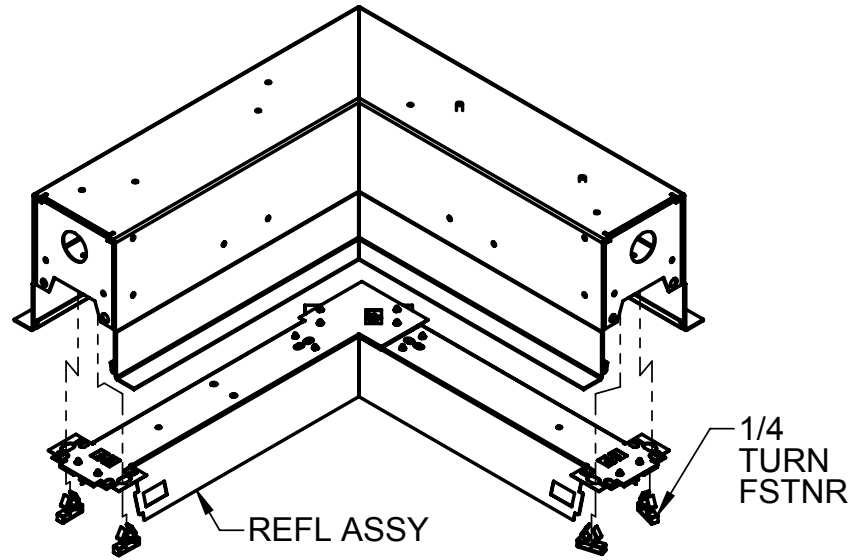

REMOVE LED REFLECTOR MODULES OF CORNER FIXTURE BY REMOVING 1/4 TURN FASTENERS. ALLOW MODULES TO HANG DOWN ON NYLON TETHERS.

2

LIFT CORNER FIXTURE INTO CEILING OPENING.

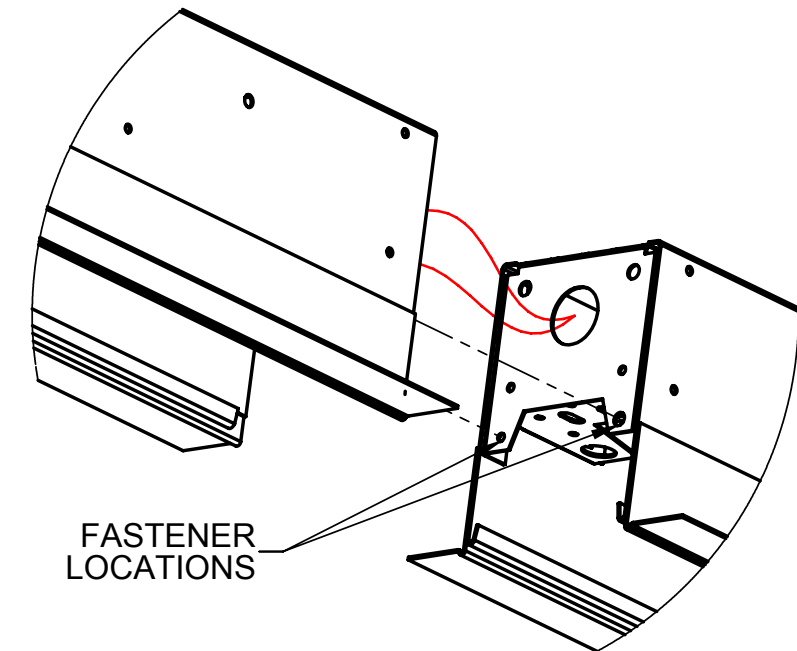

JOIN CORNER FIXTURE WITH LINEAR FIXTURES. FOR 3L, USE (2) #8 SHEET METAL SCREWS. FOR 4L AND 6L, USE (2) 8-32 X 3/8" LONG MACHINE SCREWS AND NUTS. ROUTE BRANCH CIRCUIT WIRING VIA FEED HOLE AT FIXTURE JOINT. ENSURE THAT FIXTURES ARE LEVEL AND ALIGNED BEFORE TIGHTENING SCREWS.

3

REPLACE LED REFLECTOR MODULE. CLEAN FIXTURE EXTERIORS WITH A GENERAL WINDOW CLEANER.

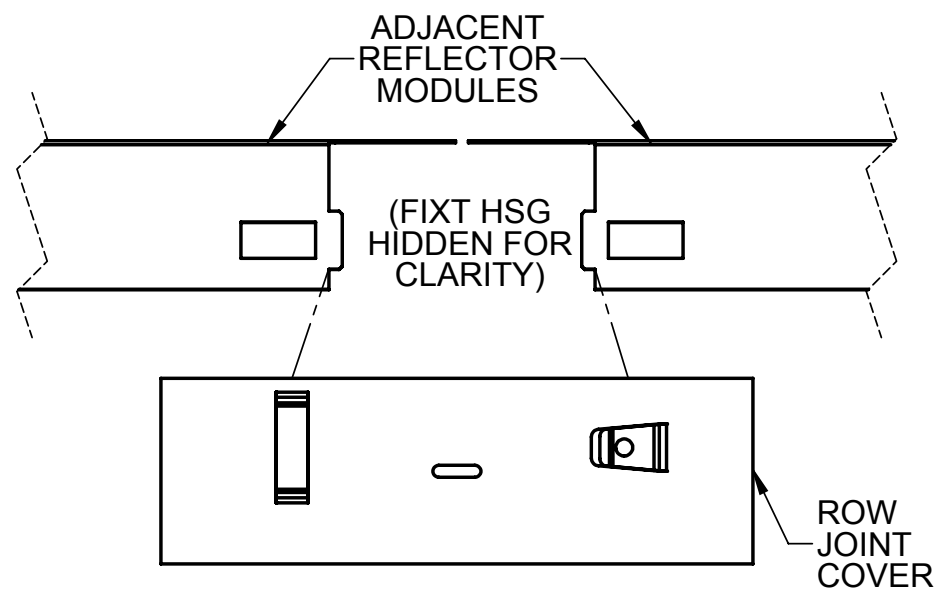

ATTACH ROW JOINT COVER PLATES, AS SHOWN, AT BOTH FIXTURE JOINTS.

4

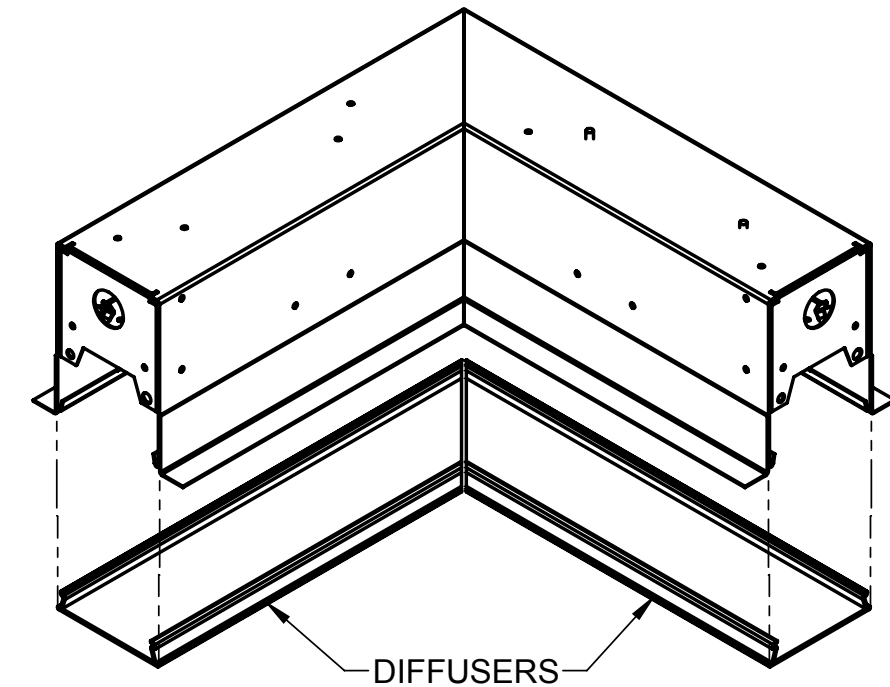

SNAP DIFFUSERS INTO BOTTOM OF HOUSING AS SHOWN. TO REMOVE, INSERT SCREWDRIVER OR FLAT HEAD PRY TOOL INTO SIDE OF HOUSING AND PULL DOWN.