



tradeSELECT™

IMPORTANT SAFEGUARDS

WARNING: RISK OF ELECTRIC SHOCK- NEVER CONNECT TO, DISCONNECT FROM, OR SERVICE WHILE EQUIPMENT IS ENERGIZED.

WARNING: FAILURE TO FOLLOW THESE INSTRUCTIONS AND WARNINGS MAY RESULT IN DEATH, SERIOUS INJURY OR SIGNIFICANT PROPERTY DAMAGE - For your protection, read and follow these warnings and instructions carefully before installing or maintaining this equipment. These instructions do not attempt to cover all installation and maintenance situations.

READ AND FOLLOW ALL SAFETY INSTRUCTIONS

1. All service shall be performed by qualified service personnel. This product must be installed and maintained in accordance with the applicable installation codes by a person familiar with the construction operation of the product and the hazards involved.
2. This product must be installed in accordance with the applicable installation codes and ordinances.
3. Before wiring to power supply, turn off electricity at fuse or circuit breaker.
4. Disconnect AC power and unplug battery before servicing.
5. Consult your local building code for approved wiring and installation.
6. UL listed for wet locations (-20°C-50°C)
7. Do not let power supply cord touch hot surfaces.
8. Do not mount near gas or electric heater.
9. Equipment should be mounted in locations and at heights where it will not readily be subjected to tampering by unauthorized personnel.
10. The use of accessory equipment not recommended by the manufacturer may cause an unsafe condition.
11. Do not use this equipment for other than intended use.
12. The AC voltage rating of this equipment is specified on the product label. Do not connect equipment to any other voltage.

INSTALLATION

WALL MOUNT INSTALLATION

1. Use flat head screwdriver to loosen the screws on the LENSES (A).
2. Remove lens from sign, set aside.
3. Remove EXIT STENCIL (B) from FIXTURE FRAME (C), set aside.
4. Drill or knock out appropriate knockouts on BACK PLATE (M) to fit junction box mounting points.
5. Drill or knock out holes in back plate for fixture supply wire leads.
6. Remove backing from self-adhesive JUNCTION BOX GASKET (F) and adhere to back plate.
7. Route fixture input wires through center hole of the back plate and make wiring connection. For 120V, use black and white wires and for 277V, use red and white wires. **WARNING:** Properly insulate the unused lead with a wire nut (provided) or other approved means.
8. Secure back plate to JUNCTION BOX (J) (hardware not included).
9. Remove proper chevron(s) from the face plate as required. When removing chevrons it may be helpful to remove the color diffuser panel to allow easier access to the chevrons. If removing color diffuser panel it is important to remember to reinstall the diffuser panel once chevron(s) have been removed.
10. Connect battery to lamp board (see wiring diagrams on page 3).
11. Secure face plate and back plate to the fixture frame.
12. Secure lens to fixture and securely torque screws.
13. Apply continuous AC power. Unit can be tested by holding the magnet (provided) near the LED indicator (where it's marked as "Magnetic Test Switch").
14. Magnet needs to be retained by building owner (or maintenance personnel) to perform monthly/ annual inspections.

CEILING OR END MOUNT INSTALLATION

1. Use flat head screwdriver to loosen the screws on the LENSES (A).
2. Remove lens from sign, set aside.
3. Remove EXIT STENCIL (B) from FIXTURE FRAME (C), set aside.
4. Drill 3/4" holes through the desired mounting knock outs located on the fixture frame. For ceiling mount, knock outs will be located on the top of the fixture frame. For wall mount, knock outs will be located on the side of the fixture frame.
5. Using provided hardware, thread NUTS (D) onto PIPE NIPPLES (E). Slide pipe nipples through canopy holes.
6. Remove backing from self adhesive JUNCTION BOX GASKET (F) and adhere to back of MOUNTING PLATE (G). Remove backing from self adhesive PIPE THREAD GASKET (H) and adhere to front of MOUNTING CANOPY (I).
7. Place screws (provided) in holes on the mounting canopy.
8. Route fixture input wires through knockout in fixture frame, pipe nut and metal MOUNTING PLATE (G).
9. Make wiring connection. For 120V, use black and white wires and for 277V, use red and white wires.
WARNING: Properly insulate the unused lead with a wire nut (provided) or other approved means.
10. Push wire connections into the J-BOX (J). Secure mounting plate to junction box (hardware not included).
11. Secure the canopy to the steel mounting plate with screws installed in step 7.
12. Place pipe nipple through the mounting hole of the fixture frame until the gasket is touching the frame. Thread a second nut onto the pipe nipple on the inside of the fixture frame to lock the canopy into place. Once canopy is locked into position there will not be any side-to-side movement of the canopy.
13. Remove proper chevron(s) as required. When removing chevrons it may be helpful to remove the color diffuser panel to allow easier access to the chevrons. If removing color diffuser panel it is important to remember to reinstall the diffuser panel once chevron(s) have been removed.

14. Connect battery to lamp board (see wiring diagrams on next page).
15. Secure face plate(s) to the fixture frame.
16. Secure lens to fixture and securely torque screws.
17. Apply continuous AC power. Unit can be tested by holding the magnet (provided) near the LED indicator (where it's marked as "Magnetic Test Switch").
18. Magnet needs to be retained by building owner (or maintenance personnel) to perform monthly/annual inspections.

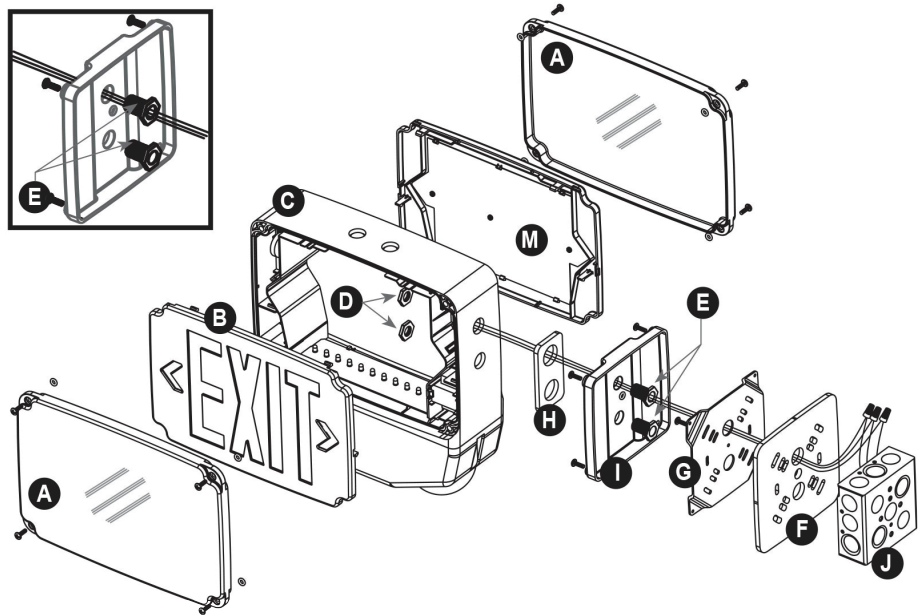

CONDUIT ENTRY

1. Drill a 3/4" hole through the desired conduit entry knock out located on the top or side of the frame of the sign.
2. Route the AC input conduit into housing.
3. All conduit connections must use UL LISTED and SUITABLE FOR WET LOCATION parts.
4. To finish installation of fixture, reference Wall, Ceiling or End Mount instructions.

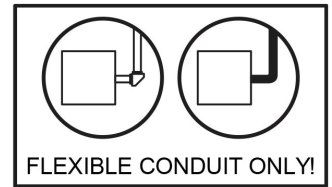

OPERATION

1. Apply AC power to the unit. The LED indicator will be GREEN.
2. After the battery has been left to charge for 2 hours, test the unit using the magnetic test switch. The LED indicator turns OFF, the LED board stays ON and the lamp heads should turn on at this time.
3. When the magnet is removed, the LED indicator turns back to GREEN, the LED board stays ON and the lamp heads should turn OFF at this time.

MAINTENANCE

Caution: Always turn off AC power to the equipment before servicing. Servicing should be performed only by a qualified service technician. Use only MANUFACTURER supplied replacement parts.

BATTERY: The battery supplied requires no maintenance. However, it should be tested periodically and replaced when it no longer operates the connected sign for the duration of a 30-second or 90-minute test. The battery supplied has a life expectancy of 5 years when used in a normal ambient temperature of 72°F. NFPA 101 (Life Safety Code) requires that all emergency lighting equipment be functionally tested every 30 days for a minimum of 30 seconds and tested annually for a full 90-minute duration. Written records of the testing are to be kept for examination by the authority having jurisdiction.

Wiring Diagrams

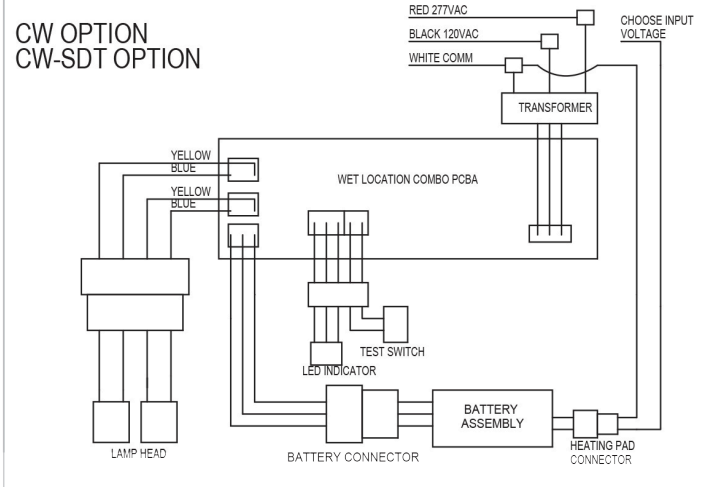
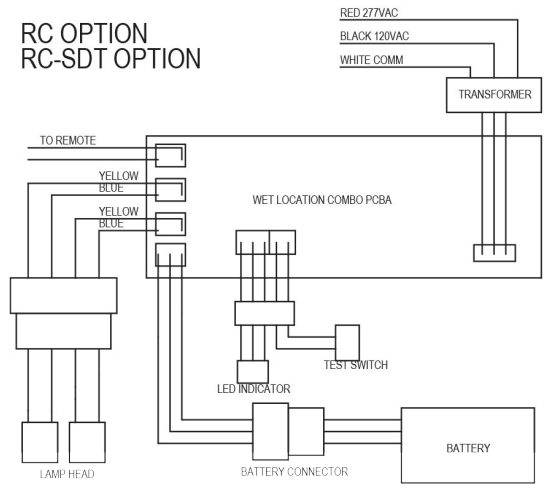
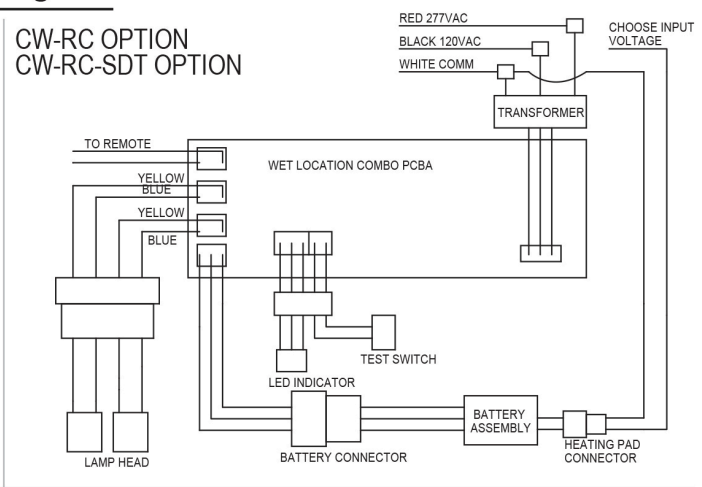
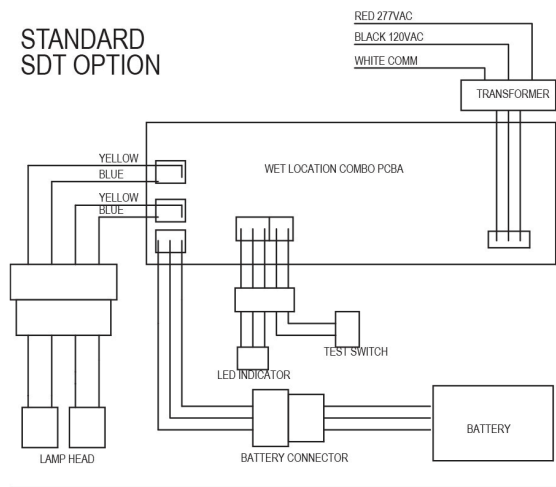

Introduction

Once the unit is properly installed according to the Installation instruction sheet and AC power is supplied, the EXIT will come ON. The dual-color LED indicator will also come ON, automatically initiating the self-diagnostic test function. The LED indicator points out the current unit status. A STEADY GREEN on the LED indicator indicates a normal service; BLINKING GREEN indicates that the unit is in testing mode; GREEN/RED FLASHING indicates that the battery is charging; RED (STEADY and BLINKING) would indicate a fault or a service alert. Refer to section 3- Fault Indication for more details. The LED indicator would be OFF when the unit is in Emergency mode.

Self- Diagnostic Service

The self-diagnostic function is factory preset without any field adjustment. The automatic self-diagnostic feature serves the following tests -

- On-line real time monitoring of battery and LED(s): Identifies battery charging, disconnection and failure along with LED failures.
- Self-testing and a 30-second discharge once every 30 days (conforming to NFPA code requirements), after AC power has been supplied for a minimum of 24 hours.
- Self-testing and a 30-minute discharge once every 180 days, after AC power has been supplied for a minimum of 24 hours.
- Self-testing and a 90-minute discharge once every 365 days (conforming to NFPA code requirements), after AC power has been supplied for a minimum of 24 hours.

Fault Indication

FAULT DESCRIPTION	LED INDICATION
Battery disconnection	STEADY Red
Battery recharge failure	FLASHING Red
Battery failure	Red BLINKING '2' times
LED failure	Red BLINKING '3' times
Lamp failure	Red BLINKING '4' times
Remote Lamp failure	Red BLINKING '5' times

* A battery recharge failure is more likely seen after a monthly or annual auto-discharge.

** A battery failure is more likely seen when the unit goes into a monthly/annual discharge test and/or fails to run the LED strip and lampheads for the designated amount of time in Test/Emergency mode.

Manual Testing

This unit also provides for manual testing by pushing the test switch in a specific pattern. The different patterns and the resulting tests are listed in the table below.

ACTION	REACTION AND LED INDICATION
Push test button Once (within 2 seconds)	30-second test: FLASHING Green
Push test button Twice (within 2 seconds)	30-minute test; Green BLINKING '2' times
Push test button Thrice (within 2 seconds)	90-minute test; Green BLINKING '3' times
Push and Hold test button (for 3-5 seconds)	Interruption
Push and Hold test button (for more than 6 seconds)	System reset

Operation

During an electrical power failure, the LED strip and lampheads will transfer into Emergency mode and stay LIT for a minimum of 90 minutes. To test this unit, the battery needs to be charged initially for 24 hours before depressing the test switch (to do manual test). On pressing the test switch, the LED strip and lampheads will transfer into a SIMULATED Emergency mode with the LED indicator FLASHING/BLINKING Green. The lampheads will turn OFF and the LED strip will continue to stay on after 30 seconds/30 minutes/90 minutes respectively.

