

### Maintenance

This emergency lighting unit should be tested and maintained in accordance with National Electrical Code and NFPA 101 Life Safety Code requirements. It is recommended that emergency light fixtures be tested for 30 seconds once a month and for 90 minutes once a year.

### Taking A Unit Out Of Service

If a unit is to be deliberately taken out of service for an extended period, the battery lead connector should be disconnected from the charger circuit board and insulated so that the battery will go into storage in a fully charged condition.

### Replacing The Battery

1. De-energize the AC power.
2. Disengage the housing cover from the backplate.
3. Disconnect the battery leads from the charger circuit board.
4. Remove the battery from the clips inside the cover.
5. Replace with a new battery (see unit model label for correct part number) and reconnect leads.
6. Reassemble cover to backplate.

### Replacing LED Lamps

The LED lamps inside the unit are not replaceable or field serviceable. Please see dual-lite.com for further assistance.

### Troubleshooting

#### Emergency circuit does not work

- Batteries are shipped uncharged and disconnected. Connect battery leads and charge 24 hours before testing.
- Make sure the charger board and test button/light pipe are properly seated and aligned.
- Check wiring connections.



# EV4R Series

## Twin Dual-Head LED Emergency Lighting Unit Standard and Spectron Equipped Models Installation, Operation, and Service Instructions



93066338

## IMPORTANT SAFEGUARDS

When using electrical equipment, basic safety precautions should always be followed including the following.

## READ AND FOLLOW ALL SAFETY INSTRUCTIONS

1. Do not use outdoors.
2. Do not let power supply cords touch hot surfaces.
3. Do not mount near gas or electric heaters.
4. Equipment should be mounted in locations and at heights where it will not readily be subject to tampering by unauthorized personnel.
5. The use of accessory equipment not authorized by the manufacturer may cause an unsafe condition.
6. Do not use this equipment for other than its intended purpose.
7. Servicing of this equipment should be performed by qualified service personnel.
8. Test cycling: the Life Safety Code (NFPA 101) requires testing of emergency lighting units once a month for a minimum of 30 seconds, and once a year for a minimum of 90 minutes.

### INSTALLER:

- SEE UNIT LABEL FOR ADDITIONAL MODEL SPECIFICATIONS
- SAVE THESE INSTRUCTIONS FOR USE BY OWNER/OCCUPANT

**WARNING** – This product contains chemicals known to the State of California to cause cancer, birth defects and/or other reproductive harm. Thoroughly wash hands after installing, handling, cleaning, or otherwise touching this product.

### Emergency Lighting Equipment For Use in Damp Locations

Damp location listed units are suitable for installation in:

1. Interior locations subject to moderate degrees of moisture, such as some basements, some barns, some cold storage warehouses, and the like.
2. Partially protected locations under canopies, marquees, roofed open porches and the like.



#### RECYCLING INFORMATION

All steel, aluminum and thermoplastic parts are recyclable.  
NOTICE: Emergency units contain rechargeable batteries which must be recycled or disposed of properly.

## BACKBOX INSTALLATION

This unit is designed to be mounted in the ceiling. Provide standard unit with a single unswitched supply from a 120-277VAC, 50/60Hz branch circuit used for normal lighting in area to be protected. For Spectron® self-testing/self-diagnostic unit, provide unit with a 120VAC or 277VAC 50/60Hz branch circuit.

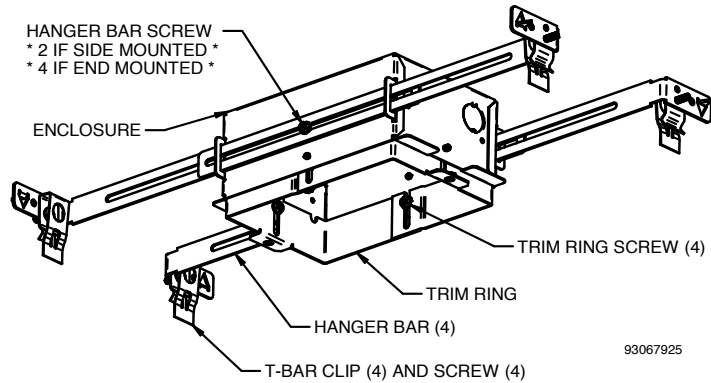

93067925

The rectangular light pattern emitted from the EV4R is oriented the same as the rectangular enclosure. Choose from below the corresponding mounting method accordingly:

### T-Grid Ceiling:

- Enclosure: 1
- Trim Ring: 1
- Trim Ring Screws: 4
- Hanger Bars: 4
- Hanger Bar Screws: 2
- T-Bar Clips: 4
- T-Bar Screws: 4

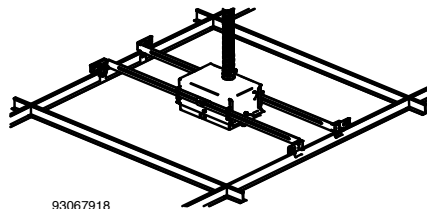

93067918

93034795

Use template provided to cut hole in ceiling tile. (Note the range of hanger bars - template should be centered along hanger bar direction.) Knock out the most convenient knock-out in the enclosure and thread wiring through, and install conduit fitting and conduit. Mount hanger bars with clips to the T-Grid. Slide the trim ring down to level of tile face and tighten trim ring screws.

### Between Joists:

- Enclosure: 1
- Trim Ring: 1
- Trim Ring Screws: 4
- Hanger Bars: 4
- Hanger Bar Screws: 2
- T-Bar Clips: 0
- T-Bar Screws: 0

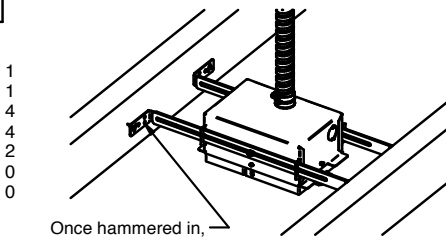

93067919

Once hammered in, add nail to each tab here

Use template provided to cut hole in ceiling. (Note the range of hanger bars - template should be centered along hanger bar direction.) Knock out the most convenient knock-out in the enclosure and thread wiring through, and install conduit fitting and conduit. Hammer hanger bars into joists and secure with one nail through one hole in each hanger bar. Slide the trim ring flush with the ceiling face and tighten trim ring screws.

### Between Joists Turned 90°:

- Enclosure: 1
- Trim Ring: 1
- Trim Ring Screws: 4
- Hanger Bars: 4
- Hanger Bar Screws: 4
- T-Bar Clips: 0
- T-Bar Screws: 0

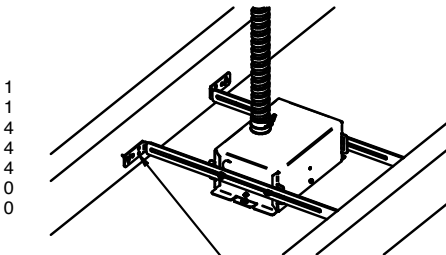

93067920

Once hammered in, add nail to each tab here

Remove the hanger bar screws on the sides of the enclosure and slide the hanger bars out of the tabs. Secure each pair of hanger bars on the ends of the enclosure with 2 screws, making sure both screws pass through the slots in both hanger bars. (The distance this hanger bar orientation will reach is limited to 21 inch joist spacing. Add spacers to joists if necessary.) Now follow "Between Joists" instructions. **Note - in this orientation, only the top enclosure knock-out can be used.**

## FIXTURE INSTALLATION

### Step 1

The EV4R is packaged with the rectangular face attached. If so desired, remove the rectangular face and replace it with the round.

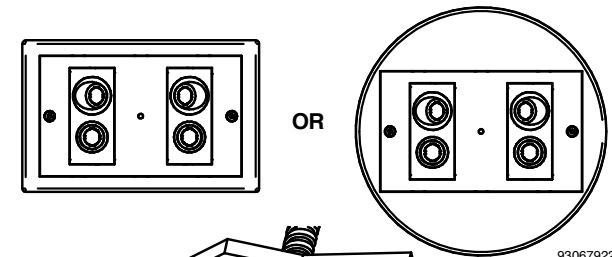

93067922

### Step 2

The EV4R unit is equipped with intelligent wiring. Connect the black wire from the unit to the hot building wire (120-277VAC 50/60Hz), the white wire to the neutral building wire, and the building ground to the green ground wire mounted inside the enclosure. Secure all with wire nuts.

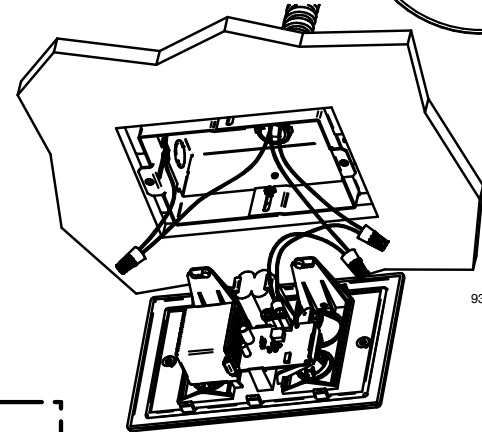

93067921

### Step 3

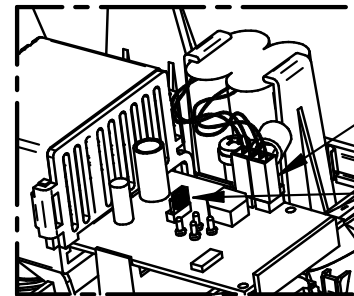

93067921

Connect both batteries to the circuit board as shown. Connect either battery to the left or right header.

Make sure the jumper is installed as shown, leaving the third pin away from the batteries exposed.

### Step 4

Tilt the adjustable LED assemblies to your ceiling height as shown below:

- 12' ceiling - position 4
- 11' ceiling - position 3
- 10' ceiling - position 2
- 9' ceiling - position 1

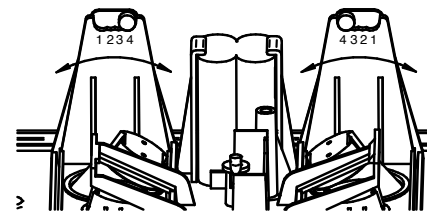

All wires and components not shown for clarity.

93067924

### Step 5

Tuck wires neatly in and insert fixture into the backbox and screw the assembly in place.

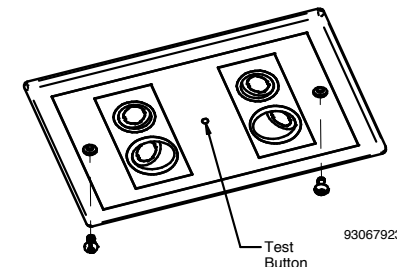

93067923

"AC ON" LED is illuminated when AC power is present.

NOTE: All models are supplied with an AC Lockout circuit, which prevents the emergency lights from illuminating when the battery is connected and no AC power is present.

NOTE: All models are supplied with a Low Voltage Disconnect circuit, which prevents damage to the battery from deep discharge during prolonged emergency operation.

NOTE: Batteries are often shipped in a discharged state – this is normal. The battery will require charging. Allow 24 hours of charging before testing the unit.

**Models with SPECTRON® Self-Testing/Self-Diagnostic Circuitry**

Models equipped with the Spectron® self-testing/self-diagnostic electronics system provide:

Visual indication of AC power status      Visual indication of self-diagnostic test status and results

**-- Visual indication of any unit malfunctions include --**

Battery Disconnected    Battery Fault    Charger Fault    LED Driver Fault    Lamp Fault

Spectron equipped units also include:

Brownout protection: unit will automatically transfer to emergency operation upon detection of low AC power (approximately 80% of nominal line).

Time Delay Retransfer: upon return of normal AC power, unit will remain in emergency mode for an additional 15 minutes to allow AC power to stabilize.

**LED Status Indicator**

A bicolor LED (green/red) is provided on the control panel of all models equipped with the Spectron® option.

**Green Operating Status LED:**

The green Operating Status LED serves as both an AC power and self-test indicator. During normal operation, the green Operating Status LED will be illuminated, indicating the presence of AC power. During all automatic or manual self-test cycles, the green Operating Status LED will blink twice every second.

**Red Service Alert LED:**

Under normal operating conditions, the red Service Alert LED indicator will remain off. If the Spectron® controller detects a malfunction, the red Service Alert LED will blink in the pattern listed in the following table:

Red Status LED Code	Description
One blink ON/pause	Battery disconnected
Two blinks ON/pause	Battery fault
Three blinks ON/pause	Charger fault
Four blinks ON/pause	LED Driver fault
Five blinks ON/pause	Lamp fault
Red/Green alternating	Load Learn in Process

**Automatic Tests**

The unit will automatically initiate a self-test/self-diagnostic cycle based on the following table:

Testing Period	Duration of Test
Once a month	1 minute
Once every 6 months	Alternating: 30 minutes or 60 minutes

**Note: After clearing a 5 blink lamp fault by initiating a load learn test, a 60 second manual test must be initiated.**

**Manual Tests**

Using the unit test switch, users can initiate different duration test cycles based on the following table:

Initiating Action	Test Cycle
Press test switch once	1 minute
Press test switch twice	90 minutes

Pressing the test switch any time after a 90 min. test cycle has begun cancels the remainder of the 90 min. test and returns the unit to normal operation.

Note: After clearing a 5 blink lamp fault by initiating a load learn test, a 60 second manual test must be initiated.

"AC ON" LED is illuminated when AC power is present.

NOTE: All models are supplied with an AC Lockout circuit, which prevents the emergency lights from illuminating when the battery is connected and no AC power is present.

NOTE: All models are supplied with a Low Voltage Disconnect circuit, which prevents damage to the battery from deep discharge during prolonged emergency operation.

NOTE: Batteries are often shipped in a discharged state – this is normal. The battery will require charging. Allow 24 hours of charging before testing the unit.

**Models with SPECTRON® Self-Testing/Self-Diagnostic Circuitry**

Models equipped with the Spectron® self-testing/self-diagnostic electronics system provide:

Visual indication of AC power status      Visual indication of self-diagnostic test status and results

**-- Visual indication of any unit malfunctions include --**

Battery Disconnected    Battery Fault    Charger Fault    LED Driver Fault    Lamp Fault

Spectron equipped units also include:

Brownout protection: unit will automatically transfer to emergency operation upon detection of low AC power (approximately 80% of nominal line).

Time Delay Retransfer: upon return of normal AC power, unit will remain in emergency mode for an additional 15 minutes to allow AC power to stabilize.

**LED Status Indicator**

A bicolor LED (green/red) is provided on the control panel of all models equipped with the Spectron® option.

**Green Operating Status LED:**

The green Operating Status LED serves as both an AC power and self-test indicator. During normal operation, the green Operating Status LED will be illuminated, indicating the presence of AC power. During all automatic or manual self-test cycles, the green Operating Status LED will blink twice every second.

**Red Service Alert LED:**

Under normal operating conditions, the red Service Alert LED indicator will remain off. If the Spectron® controller detects a malfunction, the red Service Alert LED will blink in the pattern listed in the following table:

Red Status LED Code	Description
One blink ON/pause	Battery disconnected
Two blinks ON/pause	Battery fault
Three blinks ON/pause	Charger fault
Four blinks ON/pause	LED Driver fault
Five blinks ON/pause	Lamp fault
Red/Green alternating	Load Learn in Process

**Automatic Tests**

The unit will automatically initiate a self-test/self-diagnostic cycle based on the following table:

Testing Period	Duration of Test
Once a month	1 minute
Once every 6 months	Alternating: 30 minutes or 60 minutes

**Manual Tests**

Using the unit test switch, users can initiate different duration test cycles based on the following table:

Initiating Action	Test Cycle
Press test switch once	1 minute
Press test switch twice	90 minutes

Pressing the test switch any time after a 90 min. test cycle has begun cancels the remainder of the 90 min. test and returns the unit to normal operation.