

OPERATION

Automatic Tests

The unit will automatically initiate a self-test/self-diagnostic cycle based on the following table:

Testing Period	Duration of Test
Once a month	1 minute
Once every 6 months	Alternating: 30 or 60 minutes

Manual Tests

Using the unit test switch, users can initiate different duration test cycles based on the following table:

Initiating Action	Test Cycle
Press test switch once	1 minute
Press test switch twice	90 minutes

Pressing the test switch any time after a 90 minute test cycle has begun cancels the remainder of the 90 minute test and returns the unit to normal operation.

LED Status Indicator:

A green/red LED is provided on the control pane of all models equipped with the Spectron option.

Green Operating Status LED:

The green Operating Status LED serves as both an AC power and self-test indicator. During normal operation, the green Operating Status LED will be illuminated, indicating the presence of AC power. During all automatic or manual self-test cycles, the green Operating Status LED will blink "twice" per second for the 30 / 60 / 90 minute test.

Red Service Alert LED:

Under normal operating conditions, the red Service Alert LED indicator will remain off. If the Spectron controller detects a malfunction, the red Service Alert LED will blink in the pattern listed on the label around the test button.

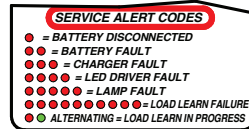

Temperature Codes and Maximum Temperature Ratings

Operating Temperature In C°		
Ambient C°	CLASS 1 DIV. 2 A,B,C,D	Supply Wire Temp. C ° Min.
50	T3C; TYPE4X	75

Service / Maintenance

Maintenance

This emergency lighting unit should be tested and maintained in accordance with National Electrical Code and NFPA 101 Life Safety Code requirements. It is recommended that emergency light fixtures be tested for 30 seconds once a month and for 90 minutes once a year.

Taking A Unit Out of Service

If a unit is to be deliberately taken out of service for an extended period, the battery lead connector should be disconnected from the charger circuit board and insulated so that the battery will go into storage in a fully charged condition.

Replacing the Battery:

1. De-energize the AC power.
2. Remove the bottom electronic housing cover.
3. Disengage the battery and heater (if provided) harness from the charger PCB harness.
4. Disconnect the battery strap and remove battery pack.
5. Replace with new battery (see unit model label or battery label for correct p/n) and repeat steps above in reverse.

Replacing LED Lamps

The LED lamps inside the exit and the lamp heads are not replaceable or field servicable.

Troubleshooting

Emergency circuit does not work

- Batteries are shipped uncharged, please charge for 24 hours before testing.
- Make sure the switch pcb and the button/light pipe is correctly seated and aligned.
- Check wiring connections.



RECYCLING INFORMATION

All steel, aluminum and thermoplastic parts are recyclable.
NOTICE: Emergency units contain rechargeable batteries which must be recycled or disposed of properly.

Hubbell Lighting, Inc. Life Safety Products • www.dual-lite.com

Copyright © Hubbell Lighting, Inc., All Rights Reserved • Specifications subject to change without notice. • Printed in U.S.A.

93117090_A 10/19

DUAL LITE®

DYNC C1D2 Series

Industrial LED Combination Exit/Emergency Light

Class 1, Division 2
Groups A,B,C,D

Class 1, Zone 2
Groups IIA, IIB, IIB+H₂, IIC

Before installation, ensure that units comply with hazardous area classification. Failure to do so may result in bodily injury and/or property damage. To prevent ignition of hazardous atmospheres, area must be free of hazardous vapors before opening enclosure or servicing fixtures. To reduce the possibility of static sparking, do not attach metallic parts to the outside of unit (i.e., metallic screws, tags decals etc.)
DO NOT ATTEMPT INSTALLATION UNTIL YOU ARE FAMILIAR WITH THE FOLLOWING PRECAUTIONS AND PROCEDURES.
CAUTION: SERVICE BY QUALIFIED PERSONNEL ONLY.
DE-ENERGIZE BEFORE OPENING.

IMPORTANT SAFEGUARDS

When using electrical equipment, basic safety precautions should always be followed including the following.

READ AND FOLLOW ALL SAFETY INSTRUCTIONS

1. Do not use outdoors (unless suitable for damp location)
2. Do not mount near gas or electric heaters
3. Equipment should be mounted in locations and at heights where it will not readily be subject to tampering by unauthorized personnel.
4. The use of accessory equipment not authorized by the manufacturer may cause an unsafe condition.
5. Do not use this equipment for other than its intended purpose.
6. Servicing of this equipment should be performed by qualified service personnel.
7. Test cycling: the Life Safety Code (NFPA 101) requires testing of emergency lighting units once a month for a minimum of 30 seconds, and once a year for a minimum of 90 minutes.

INSTALLER:

- SEE UNIT LABEL FOR ADDITIONAL MODEL SPECIFICATIONS
- SAVE THESE INSTRUCTIONS FOR USE BY OWNER/OCCUPANT

This equipment has been tested and found to comply with the limits for a Class A digital device, pursuant to part 15 of the FCC Rules. These limits are designed to provide reasonable protection against harmful interference when the equipment is operated in a commercial environment. This equipment generates, uses, and can radiate radio frequency energy and, if not installed and used in accordance with the instruction manual, may cause harmful interference to radio communications. Operation of this equipment in a residential area is likely to cause harmful interference in which case the user will be required to correct the interference at his own expense.

INSTALLATION

This Industrial Unit is designed to be mounted on a wall, ceiling or end mount. Provide standard units with a single unswitched power supply from a 120/277VAC branch circuit used for normal lighting in the areas to be protected.

The DYNC Industrial exit combo is equipped with intelligent wiring. Connect the black wire from unit to the building hot wire (120 or 277VAC) and the white wire to the building com wire.

HUBBELL Lighting

Wall Mount NEMA 4X Installation

IMPORTANT: TO WEATHERPROOF FOR OUTDOOR INSTALLATION, BE SURE TO SEAL ALL OPENINGS-MOUNTING, CONDUIT, ETC.

Note: For exits wired using conduit, use 1 of 2 fittings. For exits with -0 option use both conduit openings. One for AC and the other for DC.

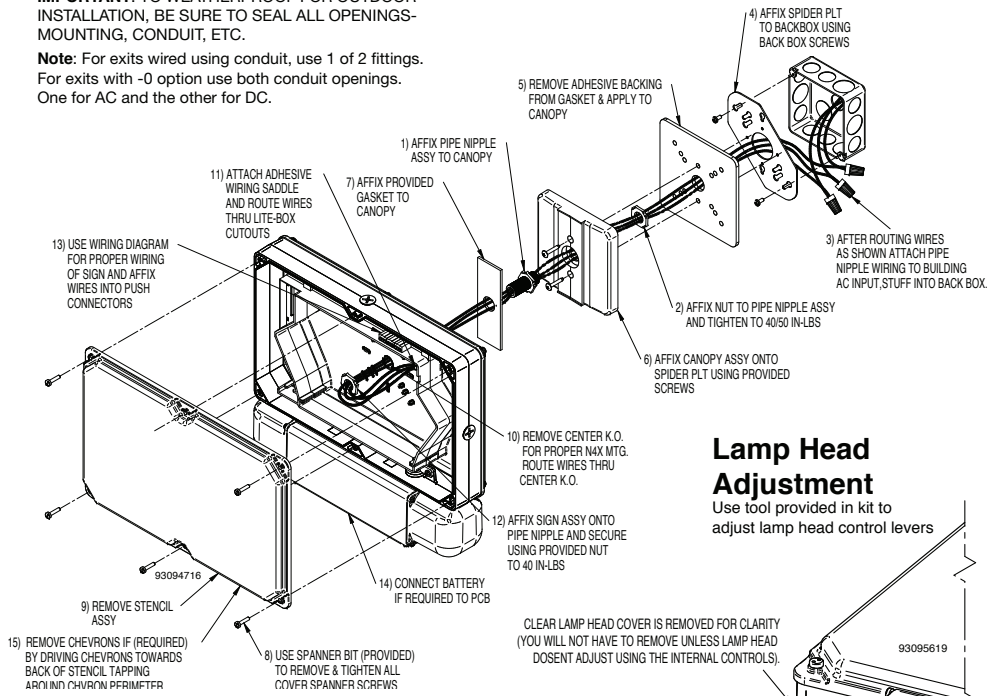

Lamp Head Adjustment

Use tool provided in kit to adjust lamp head control levers

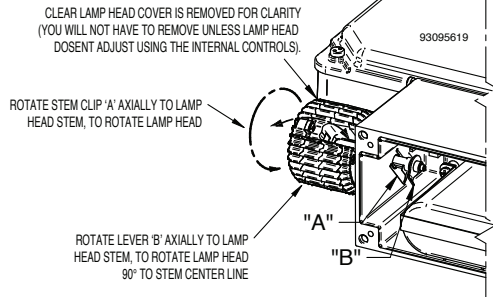

STANDARD EXIT WIRING CONENCTIONS

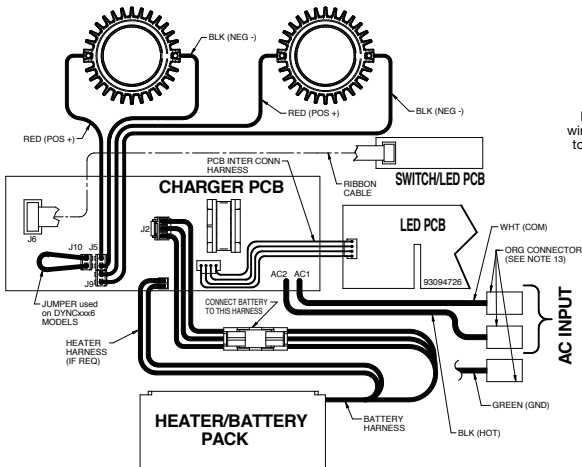

REMOTE CAPACITY AND -0 OPTION MODELS

Note: If using a double lamp head remote fixture it should be wired in series before connecting remote lamp head positive lead to pos (+) exit remote lead and remote lamp head negative lead to neg (-) exit remote lead exit orange connectors.

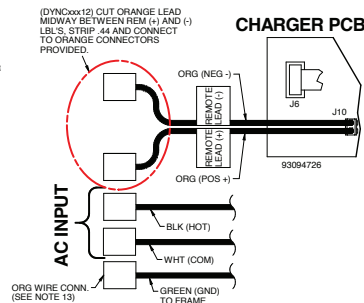

CEILING OR END MOUNT NEMA 4X INSTALLATION

IMPORTANT: TO WEATHERPROOF FOR OUTDOOR INSTALLATION, BE SURE TO SEAL ALL OPENINGS - MOUNTING, CONDUIT, ETC. FOR END MOUNTING OF SIGN USE SAME PROCEDURES AS CEILING.

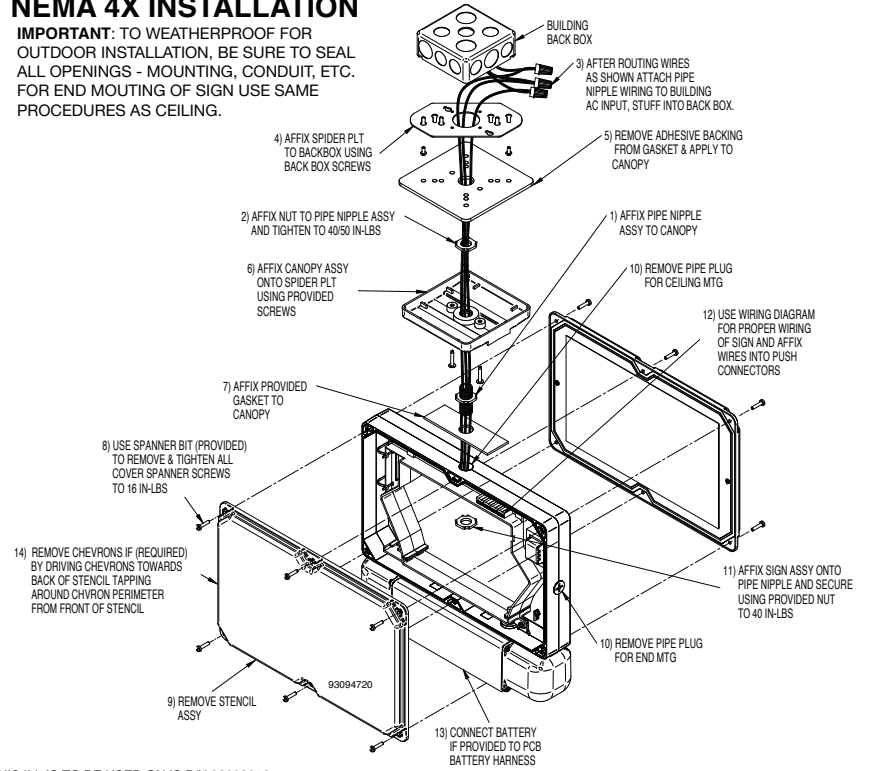

THIS ILL IS TO BE USED ON IS P/N:93093016

INITIAL INSTALLATION REQUIREMENTS

Load Learn Process

Once the green "AC ON" LED is illuminated and AC power is present, run a load learn process on all DYNCO units to include units with remotes. Run this test after the unit has been installed and any remote connections have been made. Once completed, the load value will be retained in memory for lamp load comparison.

1. Press and hold the test button for at least 5 seconds
2. Once the test button is released, the test button LED should flash red/green until the lamp load is detected
3. Once the Load Learn test is complete, the unit LED should go to steady green. If not, repeat step 1 **Note:** If 10 red flash Load Learn fault is displayed load learn process has failed. Check LED Lamp circuit wiring for proper polarity and continuity and repeat step 1.
4. Run a 1 minute test to ensure the unit is serviceable, the unit should display a blinking green LED, and go to a constant green LED after the test is complete.

Special Unit Information

This unit includes **SPECTRON Self-Diagnostic/Self-Diagnostic Circuitry**

This circuitry includes visual indication of the following unit faults;

- Battery Disconnected
- Battery Fault
- Charger Fault
- LED-Driver Fault
- Lamp Fault and Load Learn Failure

Additional Features

***Brownout Protection;** Unit automatically transfers to emergency operation upon detection of low AC power (approx. 80% of nominal line).

***Time Delay Retransfer;** upon return of normal AC power, unit will remain in emergency mode for an additional 15 minutes to allow AC power to stabilize.

***AC Lockout Circuit;** prevents the emergency lights from illuminating when the battery is connected and no AC power is present.

***Low Voltage Disconnect Circuit;** prevents damage to the battery from deep discharge during prolonged emergency operation.

NOTE: Batteries are often shipped in a discharged state - this is normal. The battery will require charging. Allow 24 hours of charging before testing the unit for a long duration.