

BUCK & BOOST TRANSFORMER INSTALLATION INSTRUCTIONS

Steps for Selecting the Proper Buck-Boost Transformer

First, you should have this information before selecting a buck-boost transformer.

Line Voltage—The voltage that you want to buck (decrease) or boost (increase). This can be found by measuring the supply line voltage with a voltmeter.

Load Voltage—The voltage at which your equipment is designed to operate. This is listed on the nameplate of the load equipment.

Load KVA or Load Amps — You do not need to know both—one or the other is sufficient for selection purposes. This information usually can be found on the nameplate of the equipment that you want to operate.

Frequency—The supply line frequency must be the same as the frequency of the equipment to be operated—either 50 or 60 cycles.

Phase—The supply line should be the same as the equipment to be operated—either single or three phase.

4 Step Selection

1 A series of LINE VOLTAGE and LOAD VOLTAGE combinations are listed across the top of each selection chart. Select a LINE VOLTAGE and LOAD VOLTAGE combination from ANY of the charts that comes closest to matching the LINE VOLTAGE and LOAD VOLTAGE of your application.

2 Read down the column you have selected until you reach either the LOAD KVA or LOAD AMPS of the equipment you want to operate. You probably will not find the exact value of LOAD KVA or LOAD AMPS so go to the next higher rating.

3 From this point, read across the column to the far left-hand side and you have found the catalog number of the exact buck-boost transformer you need.

4 CONNECT the transformer according to the connection diagram specified at the bottom of the column where you selected your LINE VOLTAGE and LOAD VOLTAGE combination.

Connection Diagrams – Single Phase

Autotransformer Overcurrent Protection

- 1 The symbol “O” used in these single phase connection diagrams illustrates where to field install an overcurrent protective device (typically a fuse or circuit breaker) when one input conductor is grounded and the other input conductor is ungrounded.
- 2 When both input conductors are ungrounded, an overcurrent protection device is required to be installed in series with each input conductor.
- 3 When the input and output are reversed, always install the overcurrent protection device in series with the input conductor(s), as noted in items No. 1 and No. 2 shown above.
- 4 For additional information, refer to the National Electrical Code, Article 450-4.

Only 1 Transformer is Required in Figure Shown Below

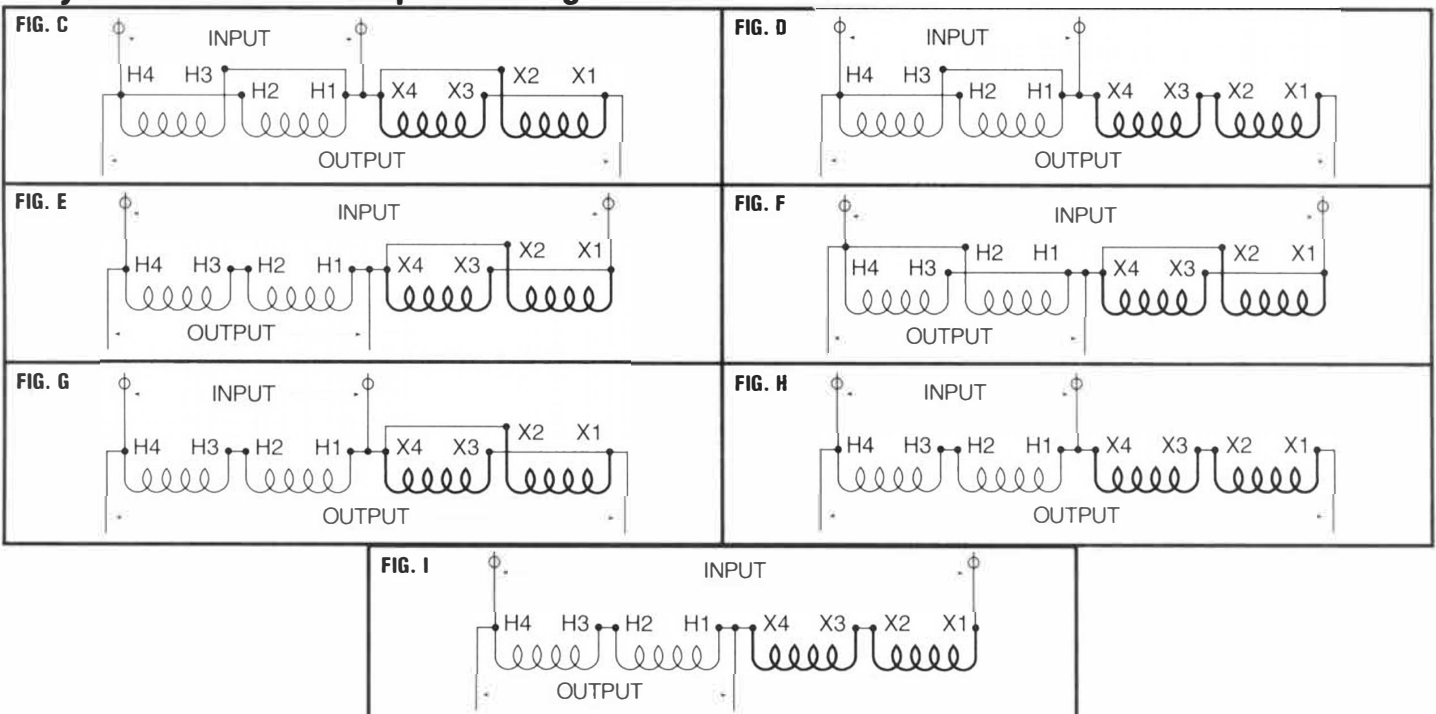

CAUTION: DO NOT USE CONNECTIONS OTHER THAN THOSE SHOWN OR PROVIDED BY FACTORY

INPUT VOLTAGE 120 X 240: OUTPUT VOLTAGE 16 X 32: 60 Hz

** All Sizes Of 3/4 KVA And Less Are Suitable For 50/60 Hz

Units Rated 120 x 240 V Input: 16 x 32 V Output		
INPUT	OUTPUT	CONNECTION DIAGRAM
120	16	K
120	32	L
240	16	M
240	32	N

CATALOG NUMBER	INSULATING TRANSFORMER RATING	MAX. CURRENT OUTPUT	
		16 V	32 V
M181054	** 50 VA	3.12	1.56
M181055	** 100 VA	6.25	3.12
M181056	** 150 VA	9.38	4.69
M181057	** 0.25 KVA	15.60	7.80
M181058	** 0.50 KVA	31.20	15.60
M181059	** 0.75 KVA	46.90	23.40
M113073	1.00 KVA	62.50	31.20
M113074	1.50 KVA	93.70	46.90
M113075	2.00 KVA	125.00	62.50
M113076	3.00 KVA	188.00	94.00
M113077	5.00 KVA	312.00	156.00
M213078	7.50 KVA	468.00	234.00
M213079	10.00 KVA	625.00	312.00

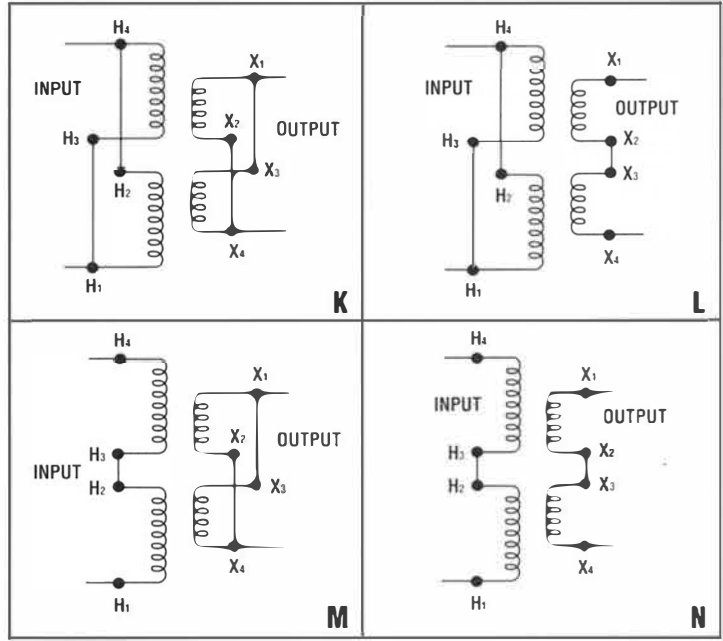

CAUTION: DO NOT USE CONNECTIONS OTHER THAN THOSE SHOWN OR PROVIDED BY FACTORY.

Three Phase Connections

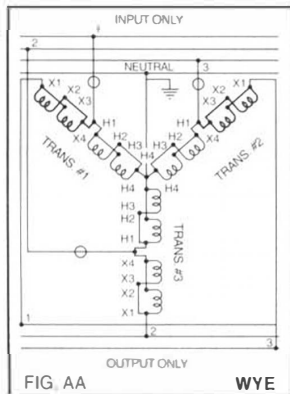
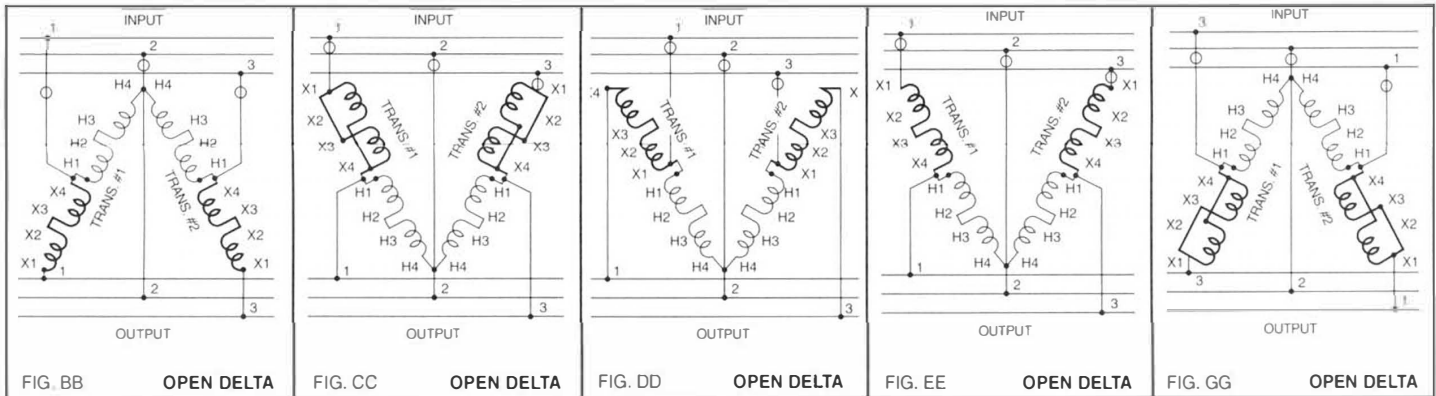

Typical Buck-Boost Autotransformer Installation

The number of Buck-Boost Transformers is shown on the connection used. It may vary from the number shown in this illustration.

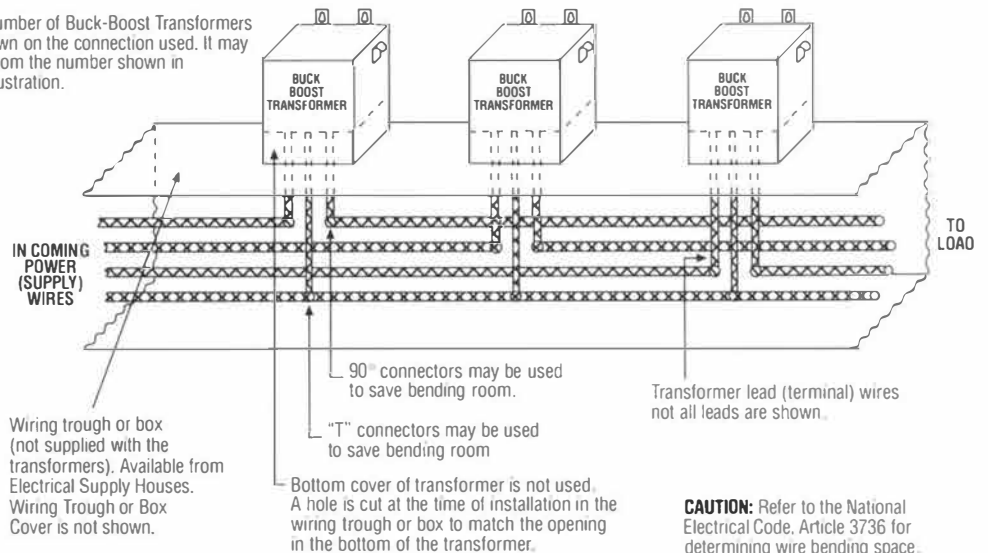

CAUTION: Refer to the National Electrical Code, Article 3736 for determining wire bending space.

Autotransformer Overcurrent Protection

The symbol "O" used in these three phase connection diagrams illustrates where to field install an overcurrent protective device (typically a fuse or circuit breaker).

When the input and output are reversed, always install the overcurrent protection device in series with the input conductors.

For additional information, refer to the National Electrical Code Article 450-4.

USE INFORMATION BELOW FOR SINGLE PHASE AUTOTRANSFORMER CONNECTIONS

GROUP II

SINGLE PHASE

SINGLE PHASE		BOOSTING							
Line Voltage (Available)		95	100	105	208	215	215	220	225
Load Voltage (Output)		120	114	119	240	244	230	235	240
M181054	Load KVA Amps	0.19 1.56	0.36 3.13	0.37 3.13	0.38 1.56	0.38 1.56	0.72 3.13	0.73 3.13	0.75 3.13
	Max. Size of Fuse or Breaker	6	6	6	6	6	6	6	6
M181055	Load KVA Amps	0.38 3.13	0.71 6.25	0.74 6.25	0.75 3.13	0.76 3.13	1.44 6.25	1.47 6.25	1.50 6.25
	Max. Size of Fuse or Breaker	10	15	6	6	15	15	15	15
M181056	Load KVA Amps	0.56 4.69	1.07 9.38	1.12 9.38	1.13 4.69	1.14 4.69	2.16 9.38	2.20 9.38	2.25 9.38
	Max. Size of Fuse or Breaker	10	15	15	10	10	15	15	15
M181057	Load KVA Amps	0.94 7.81	1.78 15.63	1.86 15.63	1.88 7.81	1.91 7.81	3.59 15.63	3.67 15.63	3.75 15.63
	Max. Size of Fuse or Breaker	15	25	25	15	15	25	25	25
M181058	Load KVA Amps	1.88 15.63	3.56 31.25	3.72 31.25	3.75 15.63	3.81 15.63	7.19 31.25	7.34 31.25	7.50 31.25
	Max. Size of Fuse or Breaker	25	45	45	25	25	45	45	45
M181059	Load KVA Amps	2.81 23.44	5.34 46.88	5.58 46.88	5.63 23.44	5.72 23.44	10.78 46.88	11.02 46.88	11.25 46.88
	Max. Size of Fuse or Breaker	40	70	70	40	40	70	70	70
M113073	Load KVA Amps	3.75 31.25	7.13 62.50	7.44 62.50	7.50 31.25	7.63 31.25	14.38 62.50	14.69 62.50	15.00 62.50
	Max. Size of Fuse or Breaker	50	90	90	50	50	90	90	90
M113074	Load KVA Amps	5.63 46.90	10.69 93.80	11.16 93.80	11.25 46.90	11.44 46.90	21.56 93.80	22.03 93.80	22.50 93.80
	Max. Size of Fuse or Breaker	80	150	150	70	70	125	125	125
M113075	Load KVA Amps	7.50 62.50	14.25 125.00	14.88 125.00	15.00 62.50	15.25 62.50	28.75 125.00	29.38 125.00	30.00 125.00
	Max. Size of Fuse or Breaker	100	200	200	90	90	175	175	175
M113076	Load KVA Amps	11.25 93.80	21.38 187.50	22.31 187.50	22.50 93.80	22.88 93.80	43.13 187.50	44.06 187.50	45.00 187.50
	Max. Size of Fuse or Breaker	150	300	300	150	150	250	250	250
M113077	Load KVA Amps	18.75 156.30	35.63 312.50	37.19 312.50	37.50 156.30	38.13 156.30	71.88 312.50	73.44 312.50	75.00 312.50
	Max. Size of Fuse or Breaker	250	450	450	225	225	450	450	450
M213078*	Load KVA Amps	28.10 234.40	53.40 468.80	55.80 468.80	56.30 234.40	57.20 234.40	107.80 468.80	110.20 468.80	112.50 468.80
	Max. Size of Fuse or Breaker	400	700	700	350	350	700	700	700
M213079*	Load KVA Amps	37.50 312.50	71.30 625.00	74.40 625.00	75.00 312.50	76.30 312.50	143.80 625.00	146.90 625.00	150.00 625.00
	Max. Size of Fuse or Breaker	500	1000	1000	450	450	1000	1000	1000
Connection Diagram		D	C	C	H	H	G	G	G

BUCKING											
135	240	240	245	250	255						
119	208	225	230	234	239						
0.42 3.54	0.37 1.77	0.75 3.33	0.77 3.33	0.78 3.33	0.80 3.33						
6	3	6	6	6	6						
0.84 7.08	0.74 3.54	1.50 6.67	1.53 6.67	1.56 6.67	1.59 6.67						
15	6	15	15	15	15						
1.26 10.63	1.11 5.31	2.25 10.00	2.30 10.00	2.34 10.00	2.39 10.00						
15	6	15	15	15	15						
2.11 17.71	1.84 8.85	3.75 16.67	3.83 16.67	3.90 16.67	3.98 16.67						
20	15	20	20	20	20						
4.21 35.42	3.68 17.71	7.50 33.33	7.67 33.33	7.80 33.33	7.97 33.33						
40	20	40	40	40	40						
6.32 53.13	5.53 26.56	11.25 50.00	11.50 50.00	11.70 50.00	11.95 50.00						
60	30	60	60	60	60						
8.43 70.83	7.37 35.42	15.00 66.67	15.33 66.67	15.60 66.67	15.93 66.67						
80	40	80	80	80	80						
12.64 106.30	11.05 53.10	22.50 100.00	23.00 100.00	23.40 100.00	23.90 100.00						
125	60	125	125	125	125						
16.86 141.70	14.73 70.80	30.00 133.30	30.67 133.30	31.20 133.30	31.87 133.30						
175	80	175	175	175	175						
25.29 212.50	22.10 106.30	45.00 200.00	46.00 200.00	46.80 200.00	47.80 200.00						
250	125	250	250	250	250						
42.15 354.20	36.83 177.10	75.00 333.30	76.67 333.30	78.00 333.30	79.67 333.30						
400	200	400	400	400	400						
63.20 531.30	55.30 265.60	112.50 500.00	115.00 500.00	117.00 500.00	119.50 500.00						
600	300	600	600	600	600						
84.30 708.30	73.70 354.20	150.00 666.70	153.30 666.70	156.00 666.70	159.30 666.70						
800	400	800	800	800	800						
Connection Diagram						F	I	E	E	E	E

NOTE: Inputs and Outputs may be reversed; KVA capacity remains constant. All applications above bold face line are suitable for 50/60 Hz. All applications below bold face line are suitable for 60 Hz only.

IMPORTANT: Refer to the N.E.C. (National Electrical Code) Article 450-4 for Overcurrent Protection of an Autotransformer.

Larger KVA buck-boost transformers utilize multiple conductors on the secondary (X) terminals as shown below.

	NUMBER OF LEADS PER TERMINATION							
	H1	H2	H3	H4	X1	X2	X3	X4
M213078	1	1	1	1	2	2	2	2
M213079	1	1	1	1	2	2	2	2

All leads with same designation (ex. X1, X1) MUST be joined together for proper operation.

USE INFORMATION BELOW FOR THREE PHASE AUTOTRANSFORMER CONNECTIONS

120 x 240 – 16 x 32

THREE PHASE		BOOSTING				
Line Voltage (Available)		183Y 106	208Y 120	195	208	225
Load Voltage (Output)		208	236	208	240	240
CAT. NO. ▲ (SEE FOOTNOTE) SHOWN ON PAGE 2						
M181054	Load	KVA 1.13	1.28	1.13	0.63	1.30
	Amps	3.13	3.13	3.13	1.56	3.13
	Max. Size of Fuse or Breaker	6	6	6	3	6
M181055	Load	KVA 2.25	2.55	2.25	1.27	2.60
	Amps	6.25	6.25	6.25	3.13	6.25
	Max. Size of Fuse or Breaker	15	15	15	6	15
M181056	Load	KVA 3.38	3.83	3.38	1.90	3.90
	Amps	9.38	9.38	9.38	4.69	9.38
	Max. Size of Fuse or Breaker	15	15	15	10	15
M181057	Load	KVA 5.63	6.39	5.63	3.17	6.50
	Amps	15.63	15.63	15.63	7.81	15.63
	Max. Size of Fuse or Breaker	25	25	25	15	25
M181058	Load	KVA 11.26	12.77	11.26	6.33	12.99
	Amps	31.25	31.25	31.25	15.63	31.25
	Max. Size of Fuse or Breaker	45	45	45	25	45
M181059	Load	KVA 16.89	19.16	16.89	9.50	19.49
	Amps	46.88	46.88	46.88	23.44	46.88
	Max. Size of Fuse or Breaker	70	70	70	35	70
M113073	Load	KVA 22.52	25.55	22.52	12.67	25.98
	Amps	62.50	62.50	62.50	31.25	62.50
	Max. Size of Fuse or Breaker	90	90	90	45	90
M113074	Load	KVA 33.77	38.32	33.77	19.00	38.97
	Amps	93.75	93.75	93.75	46.88	93.75
	Max. Size of Fuse or Breaker	150	150	125	70	125
M113075	Load	KVA 45.03	51.10	45.03	25.33	51.96
	Amps	125.00	125.00	125.00	62.50	125.00
	Max. Size of Fuse or Breaker	200	200	175	90	175
M113076	Load	KVA 67.55	76.64	67.55	38.00	77.94
	Amps	187.50	187.50	187.50	93.75	187.50
	Max. Size of Fuse or Breaker	300	300	250	150	250
M113077	Load	KVA 112.58	127.74	112.58	63.33	129.90
	Amps	312.50	312.50	312.50	156.25	312.50
	Max. Size of Fuse or Breaker	450	450	450	225	450
M213078*	Load	KVA 166.87	191.61	166.87	94.99	194.86
	Amps	468.75	468.75	468.75	234.38	468.75
	Max. Size of Fuse or Breaker	700	700	700	350	700
M213079*	Load	KVA 225.17	255.48	225.17	126.66	259.81
	Amps	625.00	625.00	625.00	312.50	625.00
	Max. Size of Fuse or Breaker	1000	1000	1000	450	1000
Quantity Required		3	3	2	2	2
Connection Diagram		A-A	A-A	G-G	B-B	G-G

THREE PHASE

BUCKING					
240	245	250	256	265	272
208	230	234	240	234	240
0.56	1.33	1.35	1.39	0.72	0.74
1.56	3.33	3.34	3.33	1.77	1.77
3	6	6	6	3	3
1.13	2.65	2.71	2.77	1.43	1.47
3.13	6.66	6.68	6.67	3.54	3.54
6	15	15	15	6	6
1.69	3.98	4.06	4.16	2.15	2.21
4.69	9.99	10.02	10.00	5.31	5.31
10	15	15	15	10	10
2.81	6.63	6.77	6.93	3.59	3.68
7.81	16.64	16.69	16.67	8.85	8.85
15	20	20	20	15	15
5.63	13.26	13.53	13.86	7.17	7.36
15.63	33.29	33.39	33.33	17.69	17.71
20	40	40	40	20	20
8.44	19.89	20.30	20.78	10.76	11.04
23.44	49.93	50.08	50.00	26.54	26.56
30	60	60	60	30	30
11.26	26.52	27.06	27.71	14.34	14.72
31.25	66.58	66.67	66.67	35.39	35.42
35	80	80	80	40	40
16.89	39.87	40.59	41.57	21.52	22.08
46.88	99.86	100.16	100.00	53.08	53.13
60	125	125	125	60	60
22.52	53.04	54.13	55.43	28.69	29.44
62.50	133.15	133.55	133.33	70.78	70.83
70	175	175	175	80	80
33.77	79.57	81.19	83.14	43.03	44.17
93.75	199.73	200.32	200.00	106.17	106.25
110	250	250	250	125	125
56.29	132.61	135.32	138.56	71.72	73.61
156.25	332.88	333.87	333.33	176.95	177.08
175	400	400	400	200	200
84.44	198.92	202.97	207.85	107.58	110.42
234.38	499.32	500.80	500.00	265.42	265.63
300	600	600	600	300	300
112.58	265.22	270.63	277.13	143.44	147.22
312.50	665.76	667.74	666.67	353.90	354.17
350	800	800	800	400	400
2	2	2	2	2	2
D-D	C-C	C-C	C-C	E-E	E-E

NOTE: (1) Inputs and Outputs may be reversed; KVA capacity remains constant. All applications above bold face line are suitable for 50/60 Hz. All applications below bold face line are suitable for 60 Hz only.
(2) Connection Diagrams A-A and F-F cannot be reverse connected.

IMPORTANT: Refer to the N.E.C. (National Electrical Code) Article 450-4 for Overcurrent Protection of an Autotransformer.

Larger KVA buck-boost transformers utilize multiple conductors on the secondary (X) terminals as shown below.

	NUMBER OF LEADS PER TERMINATION							
	H1	H2	H3	H4	X1	X2	X3	X4
M213078	1	1	1	1	2	2	2	2
M213079	1	1	1	1	2	2	2	2

All leads with same designation (ex. X1, X1) MUST be joined together for proper operation.