

Cable Gland Assembly Instructions

ICG 653 UNIV



For Armoured Cable Installation Only
 For Unarmoured Cable Installation see AI2040

A: Component Parts

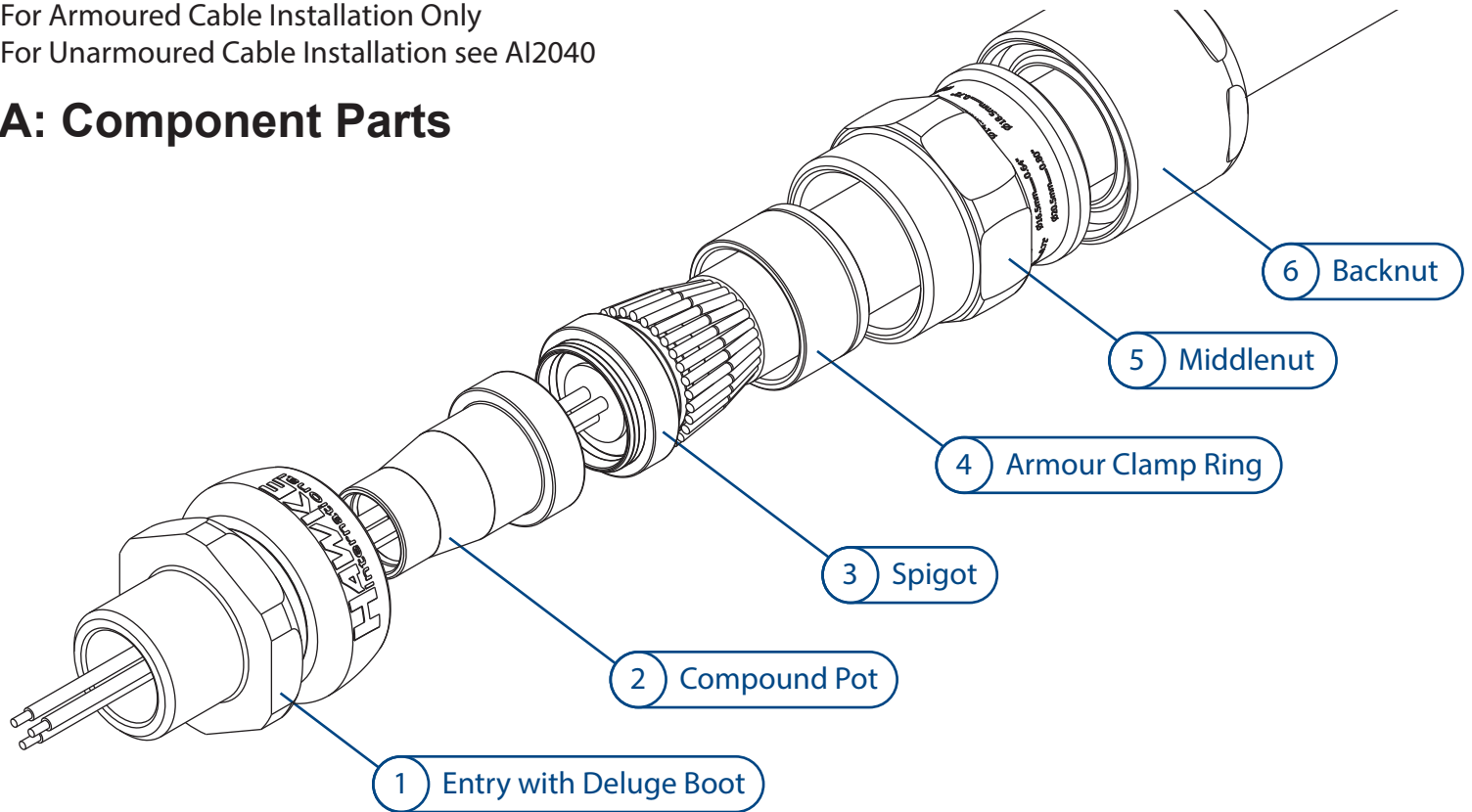

B: Cable Preparation

Slide shroud (if included), backnut ⑥, middlenut ⑤ and armour clamp ring ④ onto cable.
 Confirm orientation of armour clamp ring is correct (see table below).
 Cut cable length, strip outer sheath and cut armour to lengths as shown in table below.
 For preparation of Drain Wires see separate AI2028.
 If an inner sheath is not present and using Express Resin, use electrical tape wrapped around the base of the cores to create a suitable sealing surface.

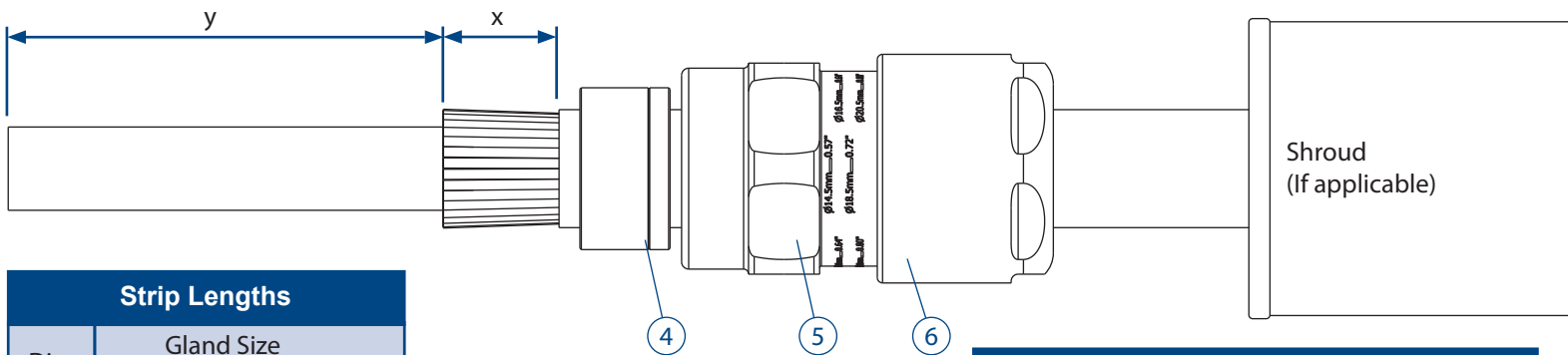

Strip Lengths			
Dim	Gland Size		
	Os-A	B-C2	D-F
x	20mm	25mm	32mm
y	To suit equipment		

Armour Clamp Ring Orientation		
Gland Size	Orientation	
	Equipment Side	Equipment Side
Os-A	0.8 - 1.25mm	0 - 0.8mm
B	1.25 - 1.6mm	0 - 0.7mm
C-C2	1.6 - 2.0mm	0 - 0.7mm
D-F	1.8 - 2.5mm	0 - 1.0mm

Tape Armour
 After tape is spread, ensure ends are trimmed at 90° as shown

C: Installing Cable Gland

STEP 1: Fit Armour To Spigot

Check cut end of cable inner sheath for any sharp edges ⑦. If necessary clean up with a knife or apply electrical tape to smooth corners.
Slide spigot ③ over cable taking care not to damage rubber resin dam.
Push armour/braid up to spigot shoulder.
Slide clamping ring ④ up to the armour/braid by hand.

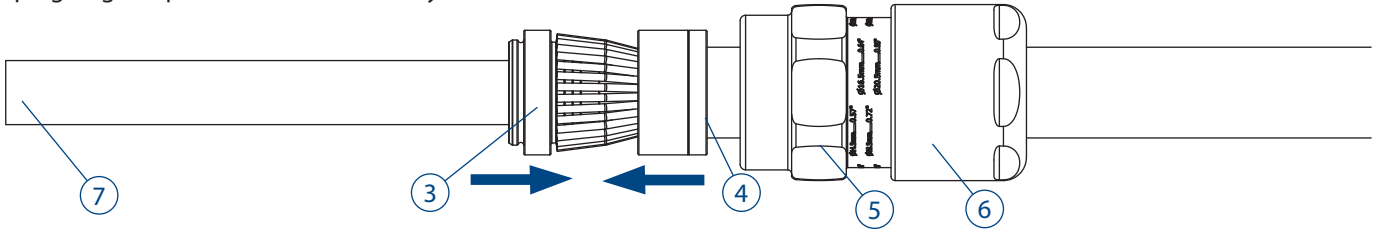

STEP 2: Prepare to Clamp Armour/Braid

Ensure compound pot ② is removed from assembly.
Slide Entry ① over cable.

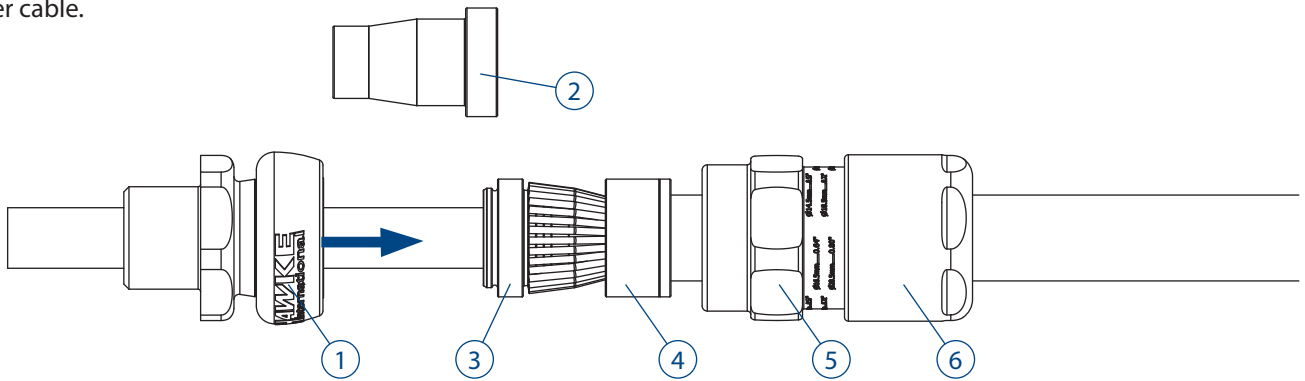

STEP 3: Clamp Armour/Braid

Slide middle nut ⑤ up to entry and hand tighten.
Grip the entry ① with a spanner/wrench.
Use a second spanner/wrench to tighten half to three quarters of a turn.

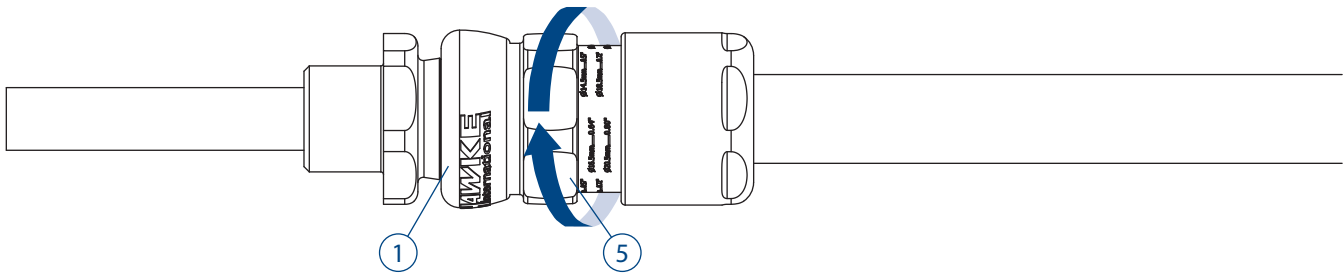

STEP 4: Inspect Armour/Braid

Unscrew the middle nut ⑤. The armour clamp ring ④ should now be locked in place.
Visually inspect that the armour/braid has been successfully clamped between the spigot ③ and the armour clamp ring ④.
If clamping is not satisfactory, repeat step 3.

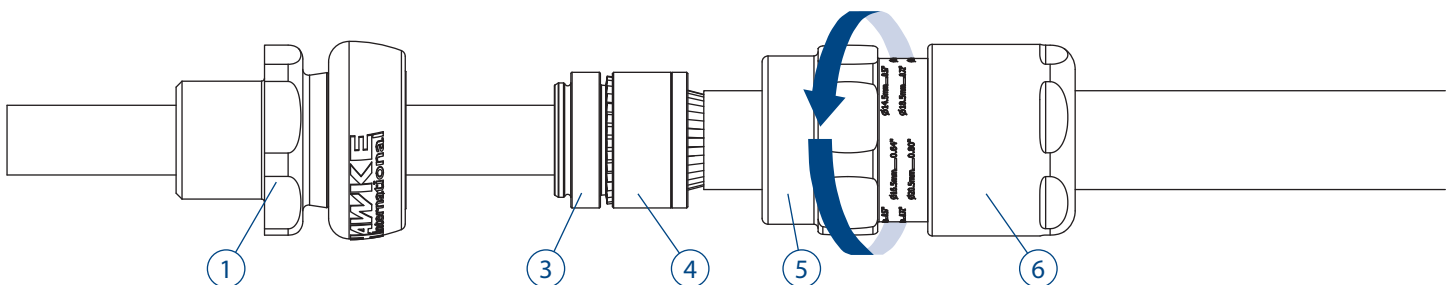

STEP 5: Strip Inner sheath to expose cores

Strip inner sheath back to between flush and 3mm from end of spigot ③, taking care not to damage resin dam.

Ensure the inner sheath protrudes through the resin dam.

Fit the pot ② and check that the inner sheath is below the height of the pot shoulder as shown below.

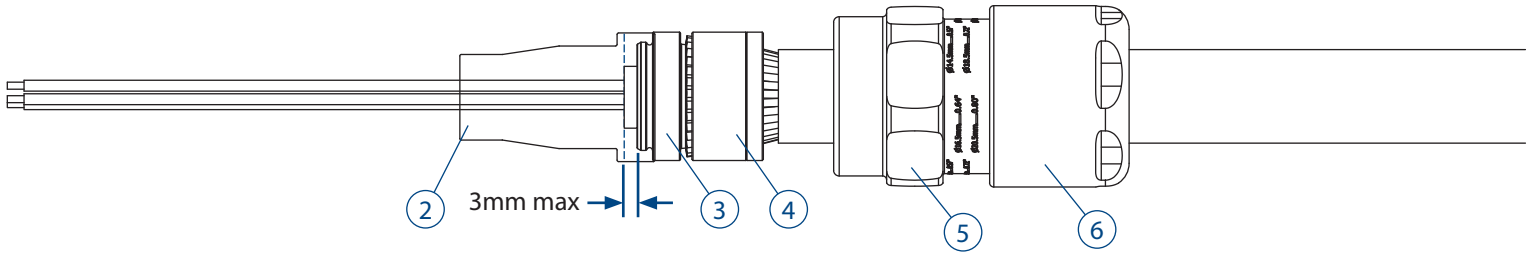

STEP 6: Pot gland with compound

Gland assembly is now ready for compound. Refer to the correct instructions depending on compound type. These instructions are supplied with the compound.

HAWKESEAL

2-Part Epoxy Putty
See AI 2034



2-Part Pouring Epoxy Resin
See AI 2035

STEP 7: Fit to Enclosure

Now potting the gland is complete, use a wrench to fit entry ① into enclosure. If required, use the appropriate IP washer ⑧.

Slide cable through entry ① until pot ② is seated in the entry.

Hand tighten the middle nut ⑤ to entry and add 1/5 - 1/4 turn with a wrench.

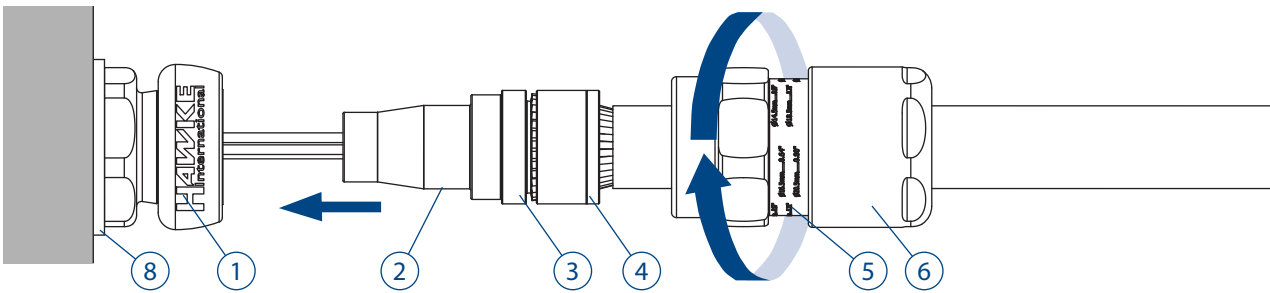

STEP 8: Install Backnut

Tighten the backnut ⑥ until a seal is formed around the cable.

Use a wrench/spanner to grip the middle nut ⑤.

While preventing the middle nut ⑤ turning, use a second wrench to apply one further full turn to the backnut ⑥.

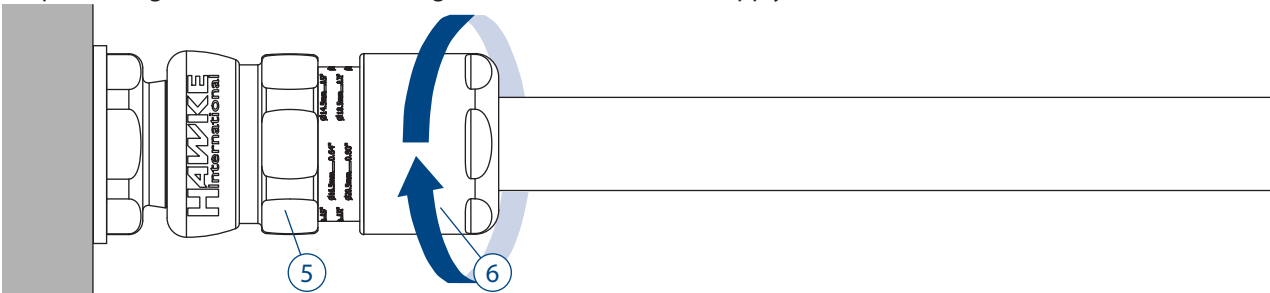

STEP 9: Inspect Backnut

Use the middle nut ⑤ guide as an indication that the backnut ⑥ is in the correct position to suit cable diameter.

Slide shroud over cable gland if applicable.

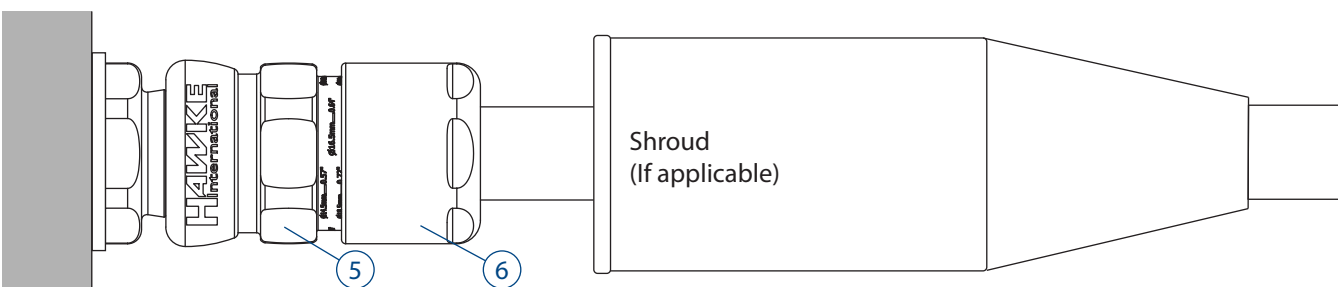

Technical Information

ICG 653 UNIV



TECHNICAL DATA

Cable Gland Type: ICG 653 UNIV
Equipment Type: Group II Barrier Cable Glands
Ingress Protection: IP66, IP67, IP68*, IP69, NEMA 4X
 *30m for 7 days to EN60529 with thread sealant, see AI464 for sealant application instructions; 10m for 24hrs no thread sealant, Os-C size only
Operating Temp: -60°C to +80°C

INSTALLATION NOTES

1. All cable glands must be installed by a suitably trained and competent individual.
2. Entry threads are in accordance with Metric BS3643 or NPT B1.20.1
3. Installer must check material compatability with enclosure and environment.
4. To maintain IP ratings, Hawke certified sealing washer or other approved sealing method must be used.
5. Sealing face surface must be smooth and free from damage
6. Wall thicknesses depended on thread length or retention type (locknut etc). Exd must maintain the requirements of IEC/EN 60079-1
7. All entries must be installed perpendicular to the mounting surface.
8. Cable gland may be used with unarmoured cable. If fitting to unarmoured cable, see AI2040 for installation instructions.

TORQUE VALUES

All torque values below were generated on metallic mandrels. For cable, it is recommended that the assembly instructions are followed.

Torque Figures N/m									
Gland Size	Os	O	A	B	C	C2	D	E	F
Middlenut Torque	6	6	8	8	10	15	15	28	35
Backnut Torque	12	12	20	30	35	45	56	60	75

ACCESSORIES

Hawke offer the following accessories to enable correct sealing and ground of cable gland.

Shroud: For additional corrosion protection
Locknut: To secure gland into position
Sealing Washer: For additional ingress protection
Earth Tag: For external bonding point
Serrated Washer: To prevent vibration loosening locknuts

SCHEDULE OF LIMITATIONS

1. When the gland is used for increased safety, the entry thread shall be suitably sealed to maintain the ingress protection rating of the associated enclosure.
2. Compound cross section must be minimum 20% of total area over a depth of 20mm

CERTIFICATION DETAILS

ATEX/IECEX/UKEx
 Ex db IIC Gb / Ex eb IIC Gb / Ex nR IIC Gc / Ex tb IIIC Db
 ATEX: CML18ATEX1268X
 IECEX: CML18.0131X UKEx: CML21UKEX1132X

NEC/CEC

Class I Div 1 ABCD, Class II Div 2 EFG and Class III
 CLI Zn1 (A)Ex db eb IIC Gb Zn21 (A)Ex tb IIIC Db
 CSA: 1024328

Additional Approvals

EAC: No EA3C RU C-GB.HA91.B.00264/21 Inmetro: IEx 14.0272X
 KCs: 17-KA4BO-0159X to 0167X PESO: P450038
 CNEX: CNEX17 2858X

CABLE GLAND SELECTION TABLE

Size Ref.	Entry Thread Size		Cable Acceptance Details								Max Length	Hexagon Dimensions	
			Inner Sheath	Cores			Outer Sheath		Steel Wire Armour/Tape/Braid			Across Flats	Across Corners
	Metric	NPT		Max. Dia	Max. Over Cores	ATEX Max. No. of Cores	Max .No. Fibre Optic	Min.	Max.	Orientation 1			
Os	M20	½"	8.1	8.0	12	48	5.5	12.0	0.8/1.25	0/0.8	72.5	24.0	26.5
O	M20	½"	11.7	8.8	12	48	9.5	16.0	0.8/1.25	0/0.8	72.5	24.0	26.5
A	M20	½" - ¾"	14.0	10.8	15	72	12.5	20.5	0.8/1.25	0/0.8	76.3	30.0	32.5
B	M25	¾" - 1"	19.9	15.9	30	144	16.9	26.0	1.25/1.6	0/0.7	81.9	36.0	39.5
C	M32	1" - 1¼"	26.2	21.9	42	-	22.0	33.0	1.6/2.0	0/0.7	89.0	46.0	50.5
C2	M40	1¼" - 1½"	32.3	26.7	60	-	28.0	41.0	1.6/2.0	0/0.7	96.4	55.0	60.6
D	M50	2"	44.2	37.7	80	-	36.0	52.6	1.8/2.5	0/1.0	122.5	65.0	70.8
E	M63	2½"	56.0	49.0	100	-	46.0	65.3	1.8/2.5	0/1.0	118.6	80.0	88.0
F	M75	3"	68.0	59.8	120	-	57.0	78.0	1.8/2.5	0/1.0	126.3	95.0	104.0

EU Declaration of Conformity in accordance with European Directive 2014/34/EU and UK Statutory Instrument 2016/1107

Manufacturer: Hawke International, Oxford Street West, Ashton-under-Lyne, OL7 0NA, United Kingdom
Equipment: ICG/653/UNIV
Provisions of the Directive fulfilled by the Equipment: Group II Category 2GD Ex db eb IIC Gb, Ex nR IIC Gc, Ex tb IIIC Db - IP66 67 68 69
Harmonized Standards used: EN 60079-0:2018, EN60079-1:2014, EN60079-7:2015+A1:2018, EN60079-15:2019, EN60079-31:2014
Notified Body for EU-Type Examination: CML B.V. 2776 Amsterdam, NLD
EU-type Examination Certificate: CML18ATEX1268X, CML19ATEX4507X (Ex nR)
Notified Body for production: 0598
Approved Body for UK-Type Examination: CML B.V. 2503 Chester, UK
UK-type Examination Certificate: CML21UKEX1132X, CML21UKEX4133X (Ex nR)
Approved Body for production: 1180
 On behalf of the above named company, I declare that on the date the equipment, accompanied by this declaration, is placed on the market the equipment conforms with all technical and regulatory requirements of the above listed directives.

Andrew Reid
 Technical Manager

www.ehawke.com

UK Office Sales: +44 (0) 161 830 6698
 Oxford Street West, Technical: +44 (0) 161 830 6697
 Ashton-under-Lyne, Fax: +44 (0) 161 830 6648
 Lancashire. OL7 0NA. UK E-mail: sales@ehawke.com

Hawke International is a division of Hubbell Ltd.
 Registered No. 669157 in England. Registered Office:
 Cannon Place, 78 Cannon Street, London EC4N 6AF.
 A member of the Hubbell Group of Companies