

### A: Component Parts

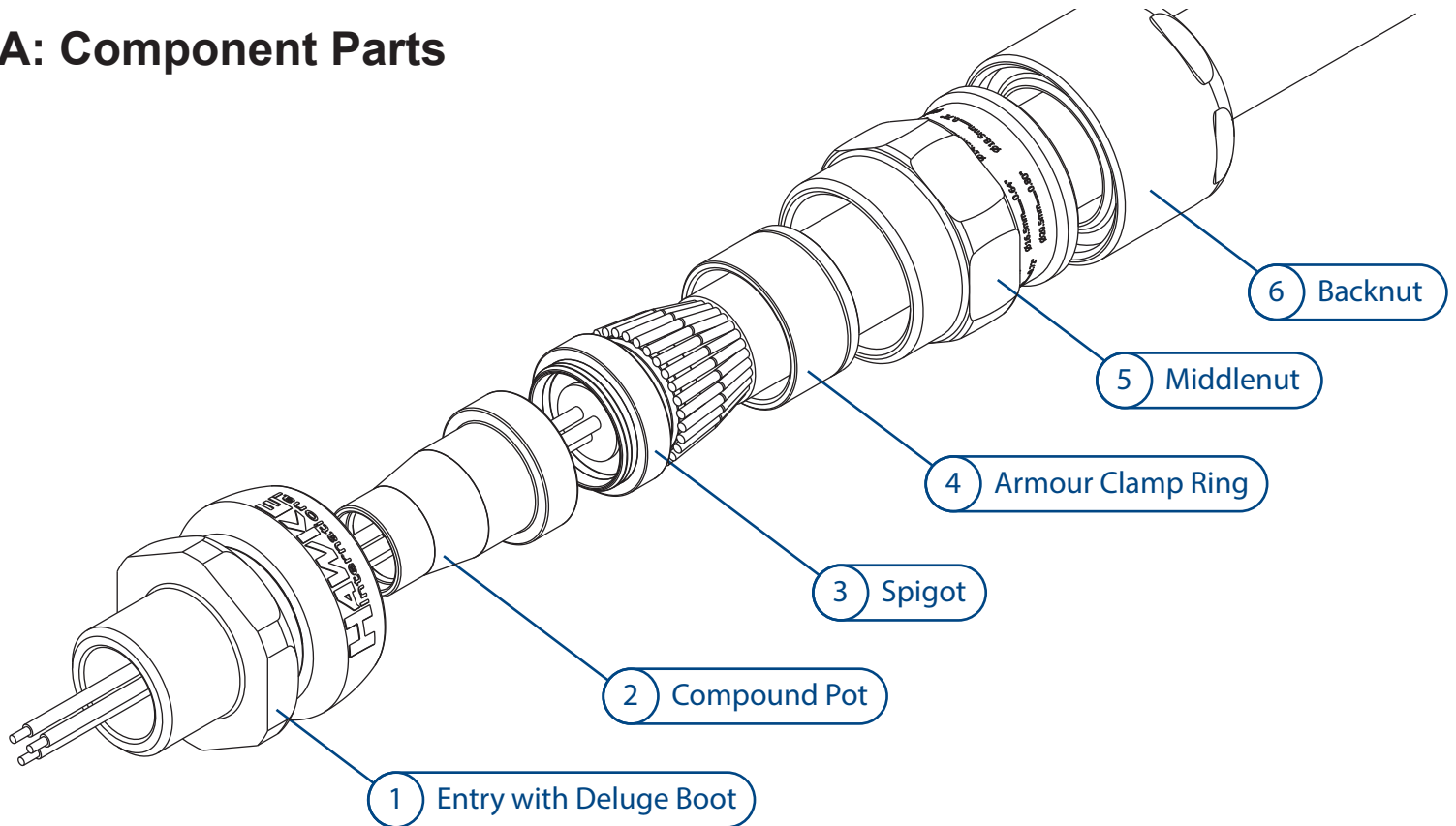

### B: Cable Preparation

Slide shroud (if included), backnut ⑥, middenut ⑤ and armour clamp ring ④ onto cable. Confirm orientation of armour clamp ring is correct (see table below). Cut cable length, strip outer sheath and cut armour to lengths as shown in table below. For preparation of Drain Wires see AI 2028. If an inner sheath is not present and using Express Resin, use electrical tape wrapped around the base of the cores to create a suitable sealing surface.

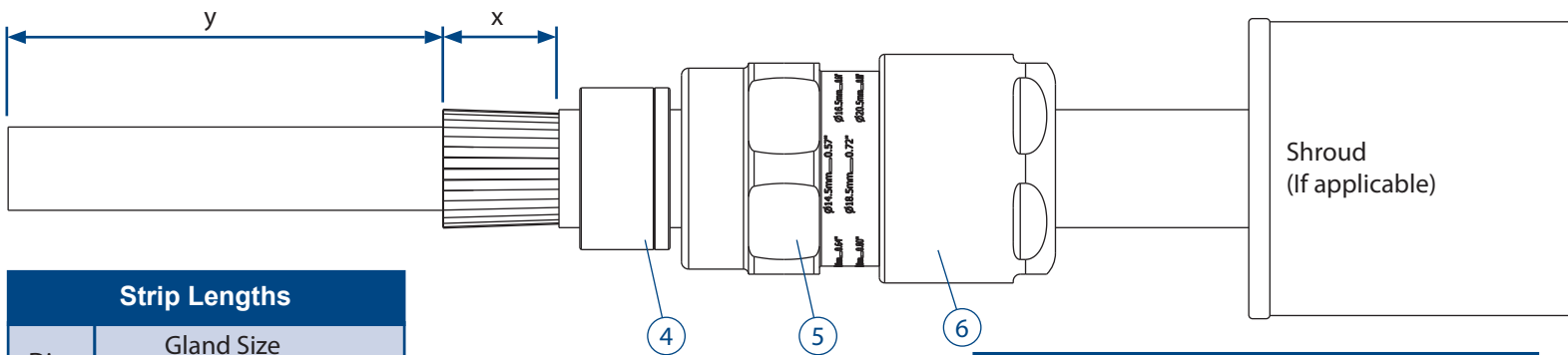

Strip Lengths			
Dim	Gland Size		
	Os-A	B-C2	D-F
x	0.75"	1"	1.25"
y	To suit equipment		

Armour Clamp Ring Orientation		
Gland Size	Orientation	
	Equipment Side	Equipment Side
Os-A	0.0315" - 0.0492"	0" - 0.315"
B	0.0492" - 0.063"	0" - 0.0276"
C-C2	0.063" - 0.0787"	0" - 0.0276"
D-F	0.0709" - 0.0984"	0" - 0.0394"

**Tape Armour**  
After tape is spread, ensure ends are trimmed at 90° as shown

# C: Installing Cable Gland

## STEP 1: Fit Armour To Spigot

Check cut end of cable inner sheath for any sharp edges ⑦. If necessary clean up with a knife or apply electrical tape to smooth corners. Slide spigot ③ over cable taking care not to damage resin dam. Push armour/braid up to spigot shoulder. Slide clamping ring ④ up to the armour/braid by hand.

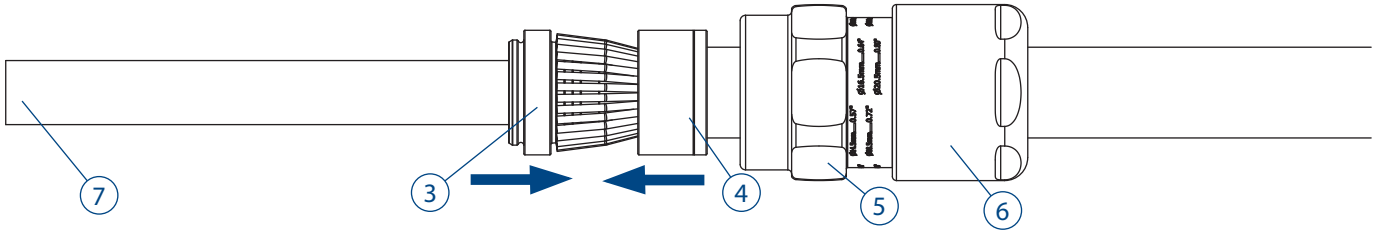

## STEP 2: Prepare to Clamp Armour/Braid

Ensure compound pot ② is removed from assembly. Slide Entry ① over cable.

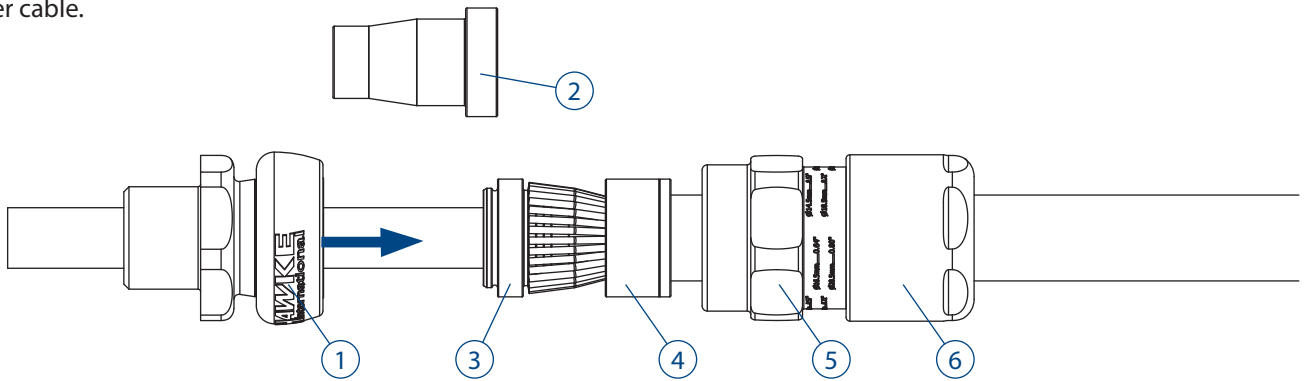

## STEP 3: Clamp Armour/Braid

Slide middle nut ⑤ up to entry and hand tighten. Grip the entry ① with a spanner/wrench. Use a second spanner/wrench to tighten half to three quarters of a turn.

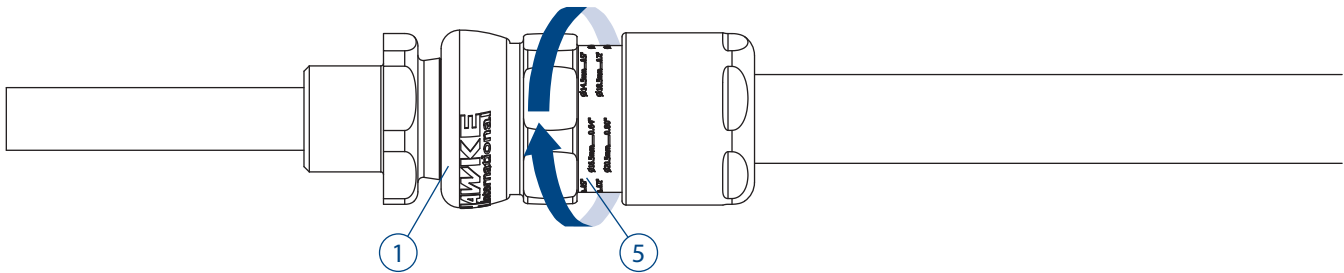

## STEP 4: Inspect Armour/Braid

Unscrew the middle nut ⑤. The armour clamp ring ④ should now be locked in place. Visually inspect that the armour/braid has been successfully clamped between the spigot ③ and the armour clamp ring ④. If clamping is not satisfactory, repeat step 3.

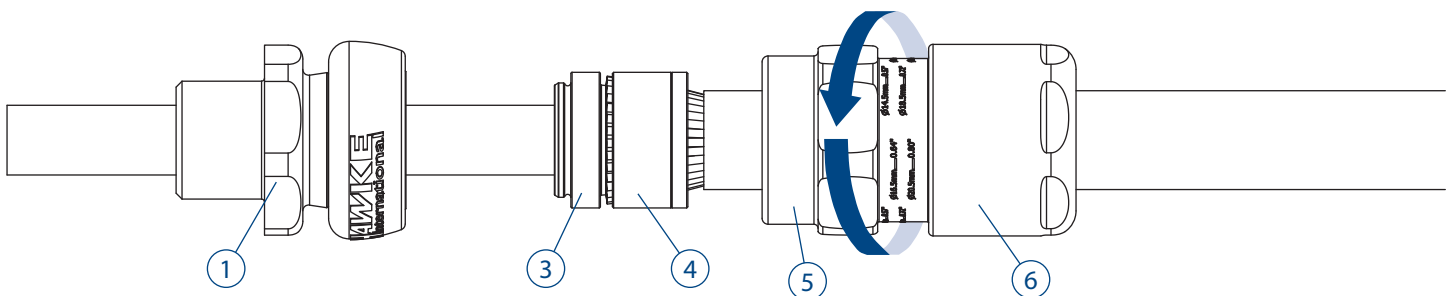

### STEP 5: Strip Inner sheath to expose cores

Strip inner sheath back to between flush and 3mm from end of spigot ③, taking care not to damage resin dam. Ensure the inner sheath protrudes through the resin dam.

Fit the pot ② and check that the inner sheath is below the height of the pot shoulder as shown below.

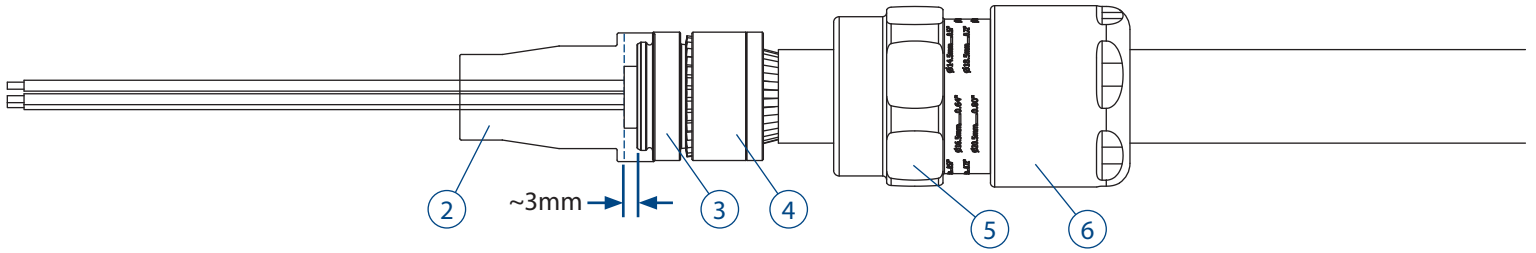

### STEP 6: Pot gland with compound

Gland assembly is now ready for compound. Refer to the correct instructions depending on compound type. These instructions are supplied with the compound.

# HAWKESEAL

2-Part Epoxy Putty  
See AI 2034



2-Part Pouring Epoxy Resin  
See AI 2035

### STEP 7: Fit to Enclosure

Now potting gland is complete, use a wrench to fit entry ① into enclosure. If required, use the appropriate IP washer ⑧.

Slide cable through entry ① until pot ② is seated in the entry.

Hand tighten the middle nut ⑤ to entry and add 1/5 - 1/4 turn with a wrench.

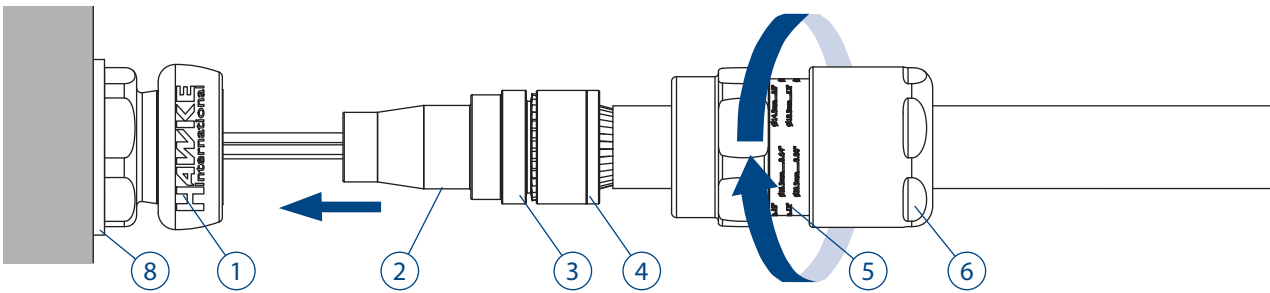

### STEP 8: Install Backnut

Hand tighten the backnut ⑥ until a seal is formed around the cable.

Use a wrench/spanner to grip the middle nut ⑤.

While preventing the middle nut ⑤ turning, use a second wrench to apply one further full turn to the backnut ⑥.

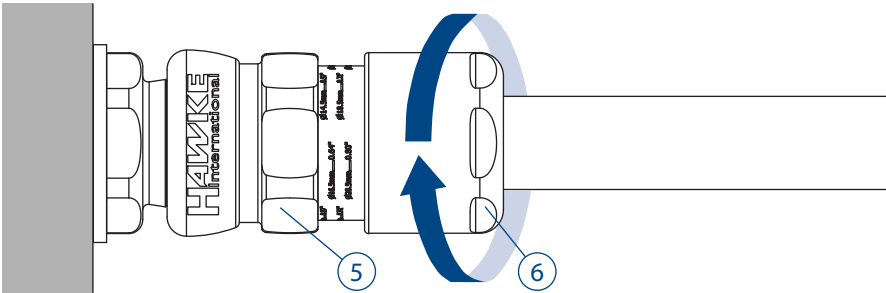

### STEP 9: Inspect Backnut

Use the middle nut ⑤ guide as an indication that the backnut ⑥ is in the correct position.

A diameter scale below is provided to assist this process.

Slide shroud over cable gland if applicable.

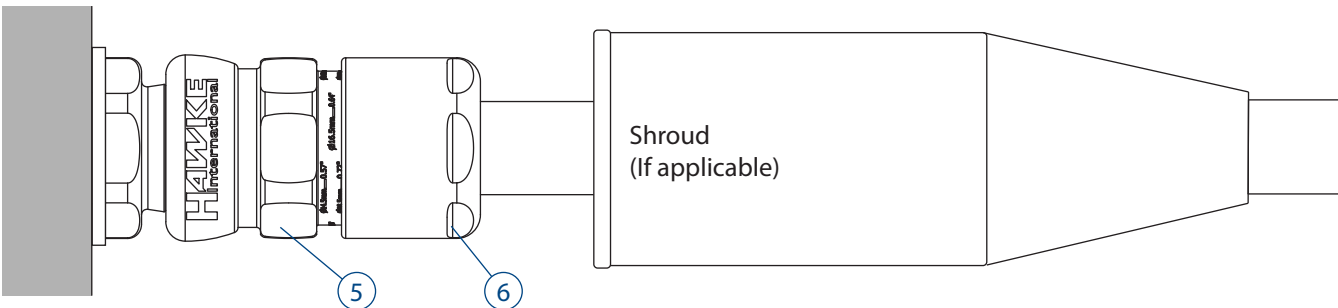

## TECHNICAL DATA

**Cable Gland Type:** 753  
**Equipment Type:** American Series Barrier Cable Glands  
**Ingress Protection:** IP66, IP67, IP68\*, IP69, Type 4X  
 \*30m for 7 days to EN60529 with thread sealant  
 10m for 24hrs no thread sealant, Os-C size only  
**Operating Temp:** -50°C to +80°C (UL)  
 -60°C to +80°C (ATEX / IECEx / UKEx)

## CERTIFICATION DETAILS

UL: Class I, Zone 1, AEx d IIC, Ex db IIC Gb, AEx e IIC, Ex eb IIC Gb,  
 Zone 21, AEx tb IIIC, Ex tb IIIC Db  
 Class I Div 1 ABCD, Class II Div 1 EFG & Class III

Listing No. E84940  
 UL listed for use with TC-ER-HL, Type P, TC, TC-ER, PLTC, PLTC-ER,  
 ITC and ITC-ER  
 Also suitable for marine shipboard cable employing copper, bronze,  
 aluminium or steel grounding braid

## ATEX/IECEx:

Ex db IIC Gb / Ex eb IIC Gb / Ex nR IIC Gc / Ex tb IIIC Db  
 ATEX: CML18ATEX1268X UKEx: CML21UKEX1132X  
 IECx: CML 18.0131X

## SPECIFIC CONDITIONS OF USE

- When the gland is used for increased safety, the entry thread shall be suitably sealed to maintain the ingress protection rating of the associated enclosure.
- Compound cross section must be minimum 20% of total area over a depth of 20mm.

## ACCESSORIES

Hawke offer the following accessories to enable correct ingress protection and grounding of cable gland.

**Shroud:** For additional corrosion protection  
**Locknut:** To secure gland into position  
**Sealing Washer:** For additional ingress protection  
**Earth Tag:** For external bonding point  
**Serrated Washer:** To prevent vibration loosening locknuts

## INSTALLATION NOTES

- All cable glands must be installed by a suitably trained and competent individual.
- Entry threads are in accordance with Metric BS3643 or ANSI/ASME B1.20.1
- Installer must check material compatibility with enclosure and environment.
- To maintain IP66/IP67/IP69, Hawke certified sealing washer or other approved sealing method must be used.
- Sealing face surface must be smooth and free from damage
- Wall thicknesses depended on thread length or retention type (locknut etc). Exd must maintain the requirements of IEC/EN 60079-1
- All entries must be installed perpendicular to the mounting surface.

## TORQUE VALUES

All torque values below were generated on metallic mandrels. For cable, it is recommended that the assembly instructions are followed.

Torque Figures N/m									
Gland Size	Os	O	A	B	C	C2	D	E	F
Middlenut Torque	6	6	8	8	10	15	15	28	35
Backnut Torque	12	12	20	30	35	45	56	60	75

## CABLE GLAND SELECTION TABLE

Size Ref.	Entry Thread Size		Cable Acceptance Details								Max Length	Hexagon Dimensions	
			Inner Jacket	Cores		Outer Sheath		Steel Wire Armour/ Tape/Braid		Across Flats		Across Corners	
	Metric	NPT		Max. Dia	Max. Over Cores	Max. No. of Cores (ATEX)	Max. No. Fibre Optic (ATEX)	Min.	Max.				Orientation 1
Os	M20	½"	0.32"	0.31"	12	48	0.22"	0.47"	0.0315"/0.0492"	0"/0.0315"	2.85"	0.94"	1.04"
O	M20	½"	0.46"	0.35"	12	48	0.37"	0.63"	0.0315"/0.0492"	0"/0.0315"	2.85"	0.94"	1.04"
A	M20	¾" or ½"	0.55"	0.43"	15	72	0.49"	0.81"	0.0315"/0.0492"	0"/0.0315"	3.00"	1.18"	1.28"
B	M25	1" or ¾"	0.78"	0.63"	30	144	0.67"	1.02"	0.0492"/0.063"	0"/0.0276"	3.22"	1.42"	1.56"
C	M32	1¼" or 1"	1.03"	0.86"	42	-	0.87"	1.30"	0.063"/0.0787"	0"/0.0276"	3.50"	1.81"	1.99"
C2	M40	1½" or 1¼"	1.27"	1.05"	60	-	1.10"	1.61"	0.063"/0.0787"	0"/0.0276"	3.80"	2.17"	2.39"
D	M50	2" or 1½"	1.74"	1.48"	80	-	1.42"	2.07"	0.0709"/0.0984"	0"/0.0394"	4.82"	2.56"	2.79"
E	M63	2½" or 2"	2.20"	1.93"	100	-	1.81"	2.57"	0.0709"/0.0984"	0"/0.0394"	4.67"	3.15"	3.46"
F	M75	3" or 2½"	2.68"	2.35"	120	-	2.24"	3.07"	0.0709"/0.0984"	0"/0.0394"	5.07"	3.74"	4.09"

### EU Declaration of Conformity in accordance with European Directive 2014/34/EU and UK Statutory Instrument 2016/1107

**Manufacturer:** Hawke International, Oxford Street West, Ashton-under-Lyne, OL7 0NA, United Kingdom  
**Equipment:** 753  
**Provisions of the Directive fulfilled by the Equipment:** Group II Category 2GD Ex db eb IIC Gb, Ex nR IIC Gc, Ex tb IIIC Db – IP66 67 68 69  
**Harmonized Standards used:** EN 60079-0:2018, EN60079-1:2014, EN60079-7:2015+A1:2018, EN60079-15:2019, EN60079-31:2014  
**Notified Body for EU-Type Examination:** CML B.V. 2776 Amsterdam, NLD  
**EU-type Examination Certificate:** CML18ATEX1268X, CML19ATEX4507X (Ex nR)  
**Notified Body for production:** 0598  
**Approved Body for UK-Type Examination:** CML B.V. 2503 Chester, UK  
**UK-type Examination Certificate:** CML21UKEX1132X, CML21UKEX4133X (Ex nR)  
**Approved Body for production:** 1180

On behalf of the above named company, I declare that on the date the equipment, accompanied by this declaration, is placed on the market the equipment conforms with all technical and regulatory requirements of the above listed directives.

Andrew Reid  
 Technical Manager