

Metallic Pot Only

If using a metallic pot version, the pot needs to be locked into the spigot. Armour grounding device should already be fitted to cable. Ensure pot orientation is correct, with indent groove at spigot end. Tighten the middle nut to entry by hand until resistance is felt. Using two wrenches/spanners tighten a further quarter of a turn. The pot should now be locked into the spigot and is ready to be potted with resin.

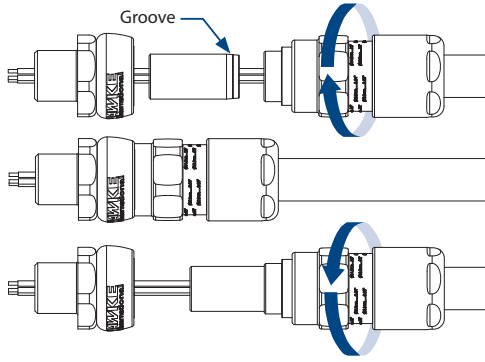

STEP 1: Cable Preparation

If an inner sheath is not present on the cable, use electrical tape wrapped around the base of the cores to create a suitable sealing surface.

If the cable is poorly filled, the following steps may be used to reduce flow of the resin down the cores of the cables.

- Wrap electrical tape around the cores at the point where they are exposed to pull the cores tightly together.
- Use a non-conductive putty or wadding to pack any large voids inbetween the cable cores.

Application Note:

Express compound has been formulated to be resistant to relevant chemical exposure and has been tested against these substances. If application presents particular risk of exposure then contact Hawke Technical for guidance.

STEP 2: Prepare cartridge for dispense

Ensure gloves provided are worn throughout filling process. Snap off / Unscrew cartridge lid and fit nozzle.

Purge approx 25mm (1") bead of resin onto a disposable surface to ensure resin is properly mixed.

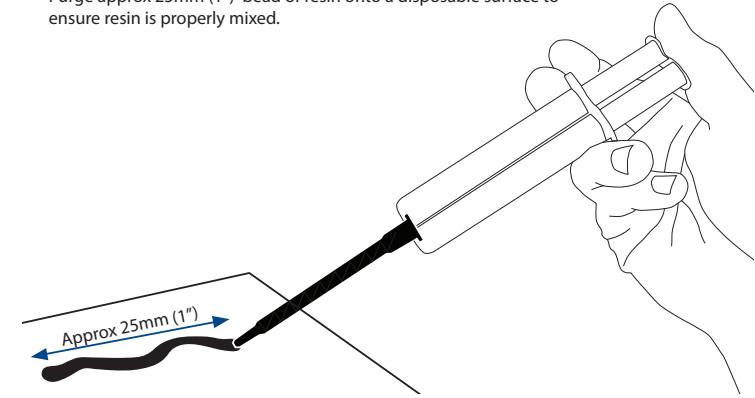

STEP 3: Dispense Resin

Gland should already be prepared for resin installation as per gland assembly instructions. Ensure gland is held vertically.

With the nozzle starting as far down the pot as possible, fill resin to approx 3mm under flush. This is indicated on the silicone pot by the fill line as shown below.

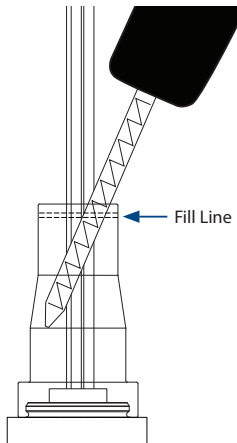

STEP 4: Inspect Resin

Check that resin is properly filled, without any voids. Manipulate the cable cores to ensure resin has filled any voids between them.

If air pockets are present, coax out from the resin by manipulating the silicone pot and using an implement to persuade out. Tape cores so they stand centrally to the pot. If fill level drops below min fill level, top up to fill line.

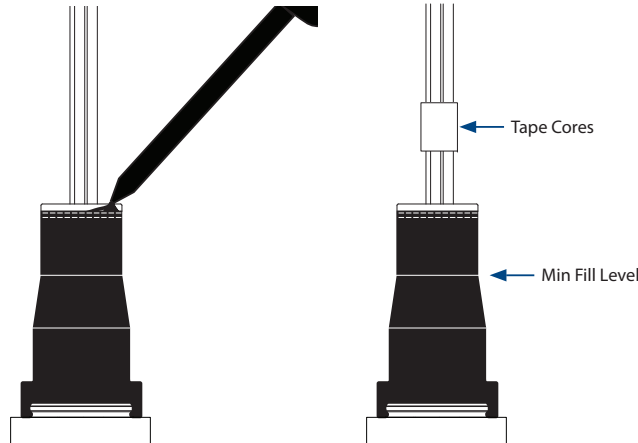

STEP 5: Allow resin to gel

Place entry over silicone pot to ensure it is held in correct shape. Allow resin to gel.

Resin gel times as shown opposite.

Depending on cable core stiffness and tightness of bend radius into enclosure, it may be possible to manipulate the cores once the resin has gelled without compromising the compound barrier.

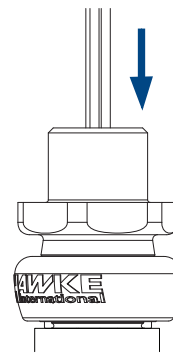

STEP 6: Continue gland installation

Gland installation can now continue as per the gland assembly instructions.

Once resin is fully cured, cores can be manipulated and system can be energised. See graph for cure times

