

Assembly Instructions for cable gland:

501/423



HAWKE International

AI 306 / Issue AA - 12/21

Operating temperature range -60°C +100°C

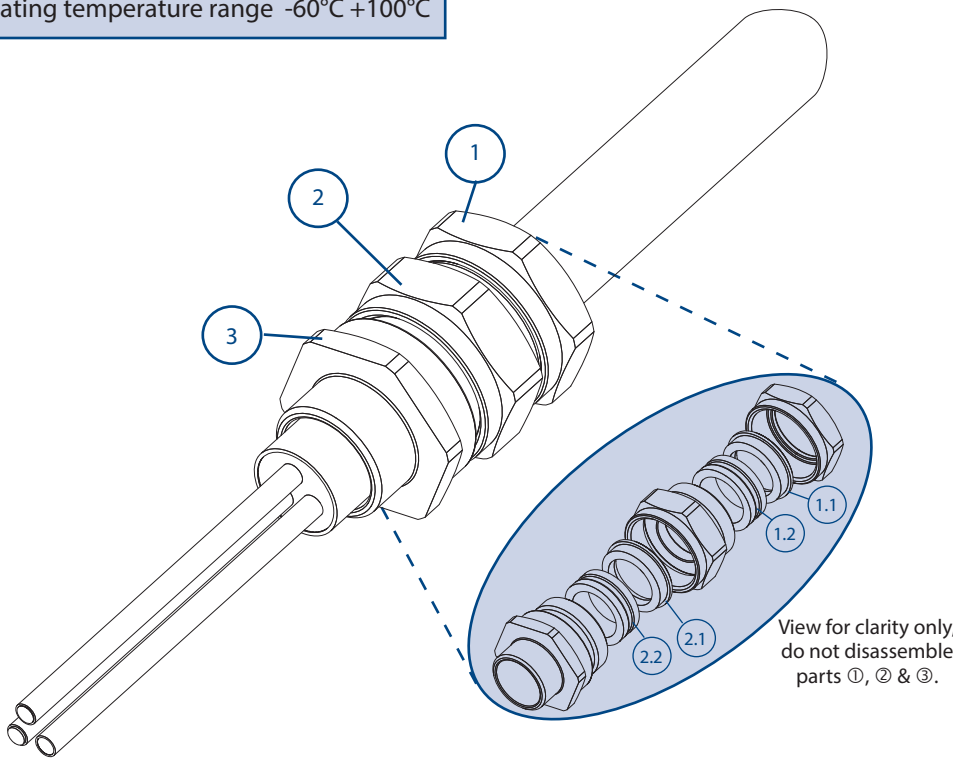

Certification Details

Gland Type: 501/423
 Ex db IIC Gb, Ex eb II Gb, Ex nR IIC Gc, Ex tb IIIC Db
 CML19ATEX1167X Ex II 2 GD IP66/67
 IECEx CML19.0045X
 IEx 14.0272X
 CML21UKEX1161X
 EAC: No EA3C RU C-GB.HA91.B.00264/21
 c CSA us No: 1015065
 Ex db IIC, C1 Zn1 (A)Ex eb II Gb Zn21 AEx tb Db
 CNEEx12.3449X

- 1. Backnut
- 1.1 Compression Spigot
- 1.2 Seal
- 2. Middle Nut
- 2.1 Compression Spigot
- 2.2 Seal
- 3. Entry

Cable Preparation

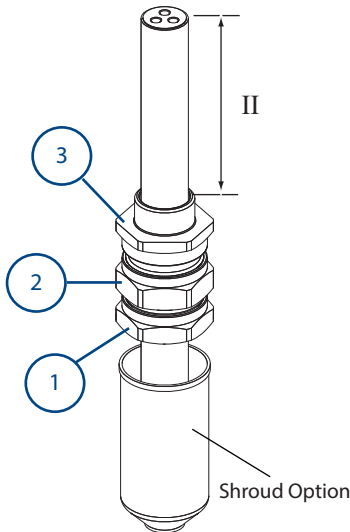

A
 Allow sufficient length of cable, II, to suit equipment.
 If required, fit shroud.
 Pass cable through cable gland as shown above.

Note: If the equipment has a threaded entry, it may be advisable to screw the cable gland into the equipment to prevent twisting of the cable after Step B & C.

Gland Preparation

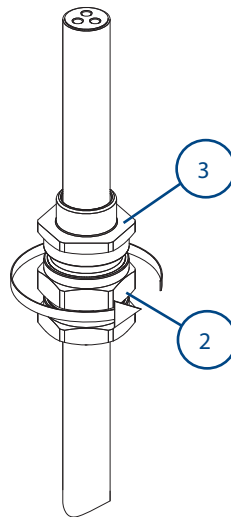

B
 Unless already screwed into the equipment hold the entry ③ in position with a spanner/wrench to prevent rotation and tighten the middle nut ② using a wrench/spanner until resistance is felt between the seal and cable. Then turn the middle nut through a further half to one full turn to complete the inner seal.

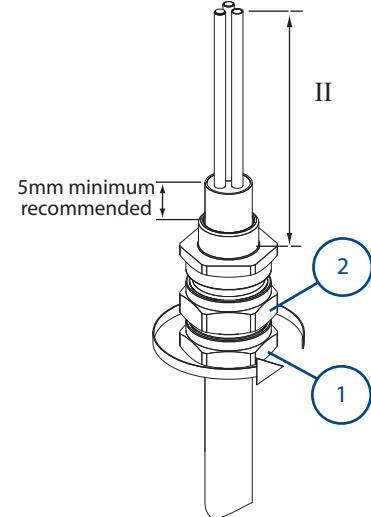

C
 Hold the middle nut ② in position with a spanner/ wrench to prevent rotation and tighten the backnut ① using a wrench/spanner until resistance is felt between the seal and cable, then turn the middle nut through a further half to one full turn to complete the outer seal. Locate the shroud over the cable gland, if applicable. To ease wiring inside the equipment it may be beneficial to strip the outer sheath of the cable, as shown above.

Images are for illustration purposes only.

Product supplied may differ slightly from that shown.

Connection Solutions

www.ehawke.com

Hawke International is a division of Hubbell Ltd.
 Registered No. 669157 in England. Registered Office:
 Cannon Place, 78 Cannon Street, London EC4N 6AF.

UK Office
 Oxford Street West,
 Ashton-Under-Lyne,
 Lancashire. OL7 0NA. UK
 Sales: +44 (0) 161 830 6698
 Technical: +44 (0) 161 830 6697
 Fax: +44 (0) 161 830 6648
 E-mail: sales@ehawke.com

CABLE GLAND SELECTION TABLE

Size Ref.	Entry Thread Size		Cable Acceptance Details				Compressed Length	Maximum Length	Hexagon Dimensions	
			Outer Sheath							
	Metric	NPT	Standard Seal		Alternative Seal (S)					
			Min.	Max.	Min.	Max.			Across Flats	Across Corners
Os	M20 [*]	½"	3.2	8.0	---	---	40.0	64	24.0	26.5
O	M20 [*]	½"	6.5	11.9	---	---	40.0	64	24.0	26.5
A	M20	½" - ¾"	10.0	14.3	9.0	13.4	40.4	60	30.0	32.5
B	M25	¾" - 1"	13.0	20.2	9.5	15.4	44.3	68	36.0	39.5
C	M32	1" - 1¼"	19.5	26.5	15.5	21.2	47.2	70	46.0	50.5
C2	M40	1¼" - 1½"	25.0	32.5	22.0	28.0	49.5	73	55.0	60.6
D	M50	1½" - 2"	31.5	42.3/44.4	27.5	34.8	72.5	100	65.0	70.8
E	M63	2" - 2½"	42.5	54.3/56.3	39.0	46.5	64.8	98	80.0	88.0
F	M75	2½" - 3"	54.5	65.3/68.2	49.5	58.3	68.0	100	95.0	104.0
G	M80	3½"	67.0	73.0	---	---	68.0	94	106.4	115.0
H	M90	3½"	67.0	77.6	---	---	68.0	94	115.0	130.0
J	M100	4"	75.0	91.6	---	---	68.0	94	127.0	142.0

- * Sizes Os and O are available with an M16 thread size. If M16 entry is used on O size Cable Glands the maximum cable inner sheath diameter is limited to 10.9mm.

ACCESSORIES:

Before cable gland assembly or stripping of the cable gland assembly, consideration should be given to any cable gland accessories that may be required, such as: -

- Shroud, to offer additional corrosion protection.
- Locknut, to secure cable glands into position.
- Sealing washer, to offer additional ingress protection of the enclosure at the cable gland entry.
- Serrated washer, to dampen any vibrations that may loosen the locknut or cable gland assembly.

SCHEDULE OF LIMITATIONS - ATEX / IECEx:

1. These cable gland types are only suitable for use with fixed apparatus, the cable for which must be effectively clamped and cleated elsewhere.
2. This cable gland has an operating temperature range of -60°C to +100°C.
3. A seal must be formed between the equipment and the cable gland to maintain the appropriate degree of protection against ingress of dust, solid objects and water.

TORQUE VALUES

All torque values below were generated on metallic mandrels. For cable, it is recommended that the assembly instructions are followed.

Torque Figures N/m									
Gland Size	Os	O	A	B	C	C2	D	E	F
Backnut & Middlednut Torques	30	30	32.5	47.5	55	65	82.5	97.5	115

NOTES - c CSA us:

1. The cable used must have extruded sealing (solid polymeric) completely surrounding the "core" (insulation and conductor), allowing for no holes or ventilation through the inner jacket or along the cores.
2. The 501/4** series cable gland connectors, when used in Class 1 Division 2 Classified areas, are not suitable to be interfaced with an explosion proof enclosure containing arcing and sparking devices, unless installed in conjunction with an approved explosion proof sealing fitting.
3. These glands are suitable for use with Certified Marine Shipboard armoured / unarmoured cables constructed to CSA Standard 245 and IEEE45 / IEC 600092-353 Standards, or certified equivalent), for use on Shipboards and Offshore Rigs / Platforms.
4. Must comply with Canadian Electrical Code and National Electric Code requirements for threaded entries.
5. For Exe applications, a sealing washer or thread sealant may be required between the enclosure and the gland to maintain the IP rating of the enclosure.
6. When used with unarmoured or braided cables the glands are only suitable for use with fixed apparatus and the cable must be effectively clamped and cleated elsewhere.
7. This cable gland may only be installed when temperature is above -5°C. After completion of the installation, the assembly is then suitable for -60°C to +100°C.

EU Declaration of Conformity in accordance with European Directive 2014/34/EU and UK Statutory Instrument 2016/1107

Manufacturer: Hawke International, Oxford Street West, Ashton-under-Lyne, OL7 0NA, United Kingdom
Equipment: 501/423

Provisions of the Directive fulfilled by the Equipment: Group II Category 2GD Ex db eb IIC Gb, Ex nR IIC Gc, Ex tb IIIC Db – IP66 67
Harmonized Standards used: EN 60079-0:2018, EN60079-1:2014, EN60079-7:2015+A1:2018, EN60079-15:2019, EN60079-31:2014

Notified Body for EU-Type Examination: CML B.V. 2776 Amsterdam, NLD
EU-type Examination Certificate: CML19ATEX1167X, CML19ATEX4507X (Ex nR)
Notified Body for production: 0598

Approved Body for UK-Type Examination: CML B.V. 2503 Chester, UK
UK-type Examination Certificate: CML21UKEX1161X, CML21UKEX4133X (Ex nR)
Approved Body for production: 1180

On behalf of the above named company, I declare that on the date the equipment, accompanied by this declaration, is placed on the market the equipment conforms with all technical and regulatory requirements of the above listed directives.

 Andrew Reid
 Technical Manager