

Assembly Instructions for cable gland: 501/414

Operating temperature range -60°C +100°C

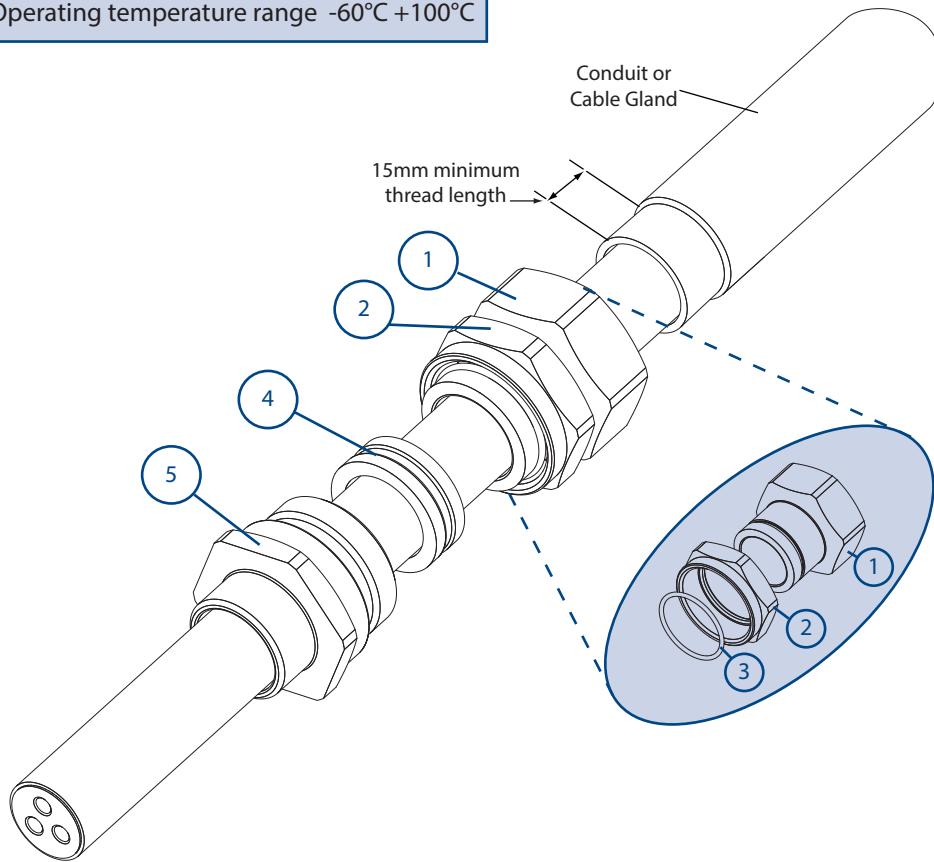

Certification Details

Gland Type: 501/414 Exdb IIC Gb / Exeb IIC Gb / Extb IIIC Db
 CML19ATEX1167X Ex II 2 GD IP66/67 CE
 IECEX CML 19.0045X
 EAC Pending
 IEx 14.0272X
 c CSA us No: 1015065
 Class 1 Zone 1 AExd IIC, AExe II Zone 21 AExtD
 Class 1 Div 2 ABCD, Class II Div 2 Groups EFG, Class III

- | | |
|--------------------|----------------|
| 1. Backnut | } Sub-Assembly |
| 2. Running Coupler | |
| 3. Spring Clip | |
| 4. Seal | |
| 5. Entry | |

IMPORTANT: Prior to installation, it may be necessary to release conduit from its clamping mechanism to allow sufficient movement.

Cable Preparation

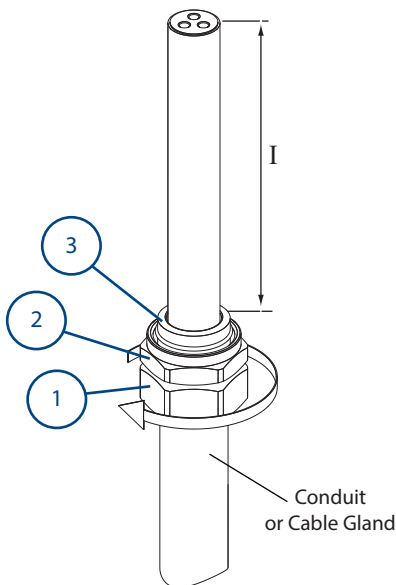

A Pull sufficient length 'I' of cable through conduit/cable gland to suit equipment. Screw backnut ① onto pre-threaded conduit/cable gland and tighten with spanner/wrench.

Gland Preparation

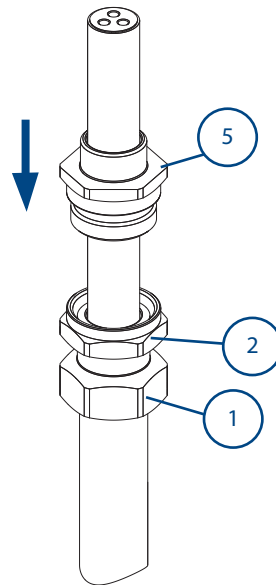

B Pass the cable through the entry ⑤ and seal ④ which may have previously been fitted into the equipment.

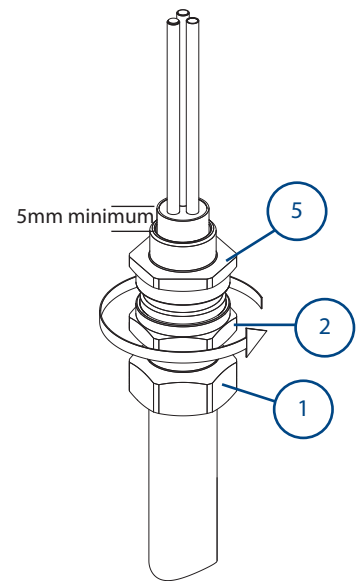

C Locate the running coupler ② onto the entry ⑤ and tighten using a wrench/spanner until resistance is felt between the seal and cable, then turn the running coupler through a further half to one full turn to complete the inner seal, ensuring that entry ⑤ is prevented from turning and backnut ① remains tight on the conduit. This procedure compresses the seal ④ into contact with the cable outer sheath.

CONDUIT CABLE GLAND SELECTION TABLE												
Size Ref.	Male Entry Thread Size		Female Entry Thread Size		Outer Sheath				Compressed Length	Maximum Length	Hexagon Dimensions	
	Metric	NPT	Metric	NPT	Standard Seal		Alternative Seal (S)				Across Flats	Across Corners
					Min.	Max.	Min.	Max.				
Os	M20*	½"	M20	#	3.2	8.0	---	---	54.5	69	24.0	26.5
O	M20*	½"	M20	#	6.5	11.9	---	---	54.5	69	24.0	26.5
A	M20	½" - ¾"	M20	#	10.0	14.3	9.0	13.4	56.4	69	30.0	32.5
B	M25	¾" - 1"	M25	#	13.0	20.2	9.5	15.4	48.2	61	36.0	39.5
C	M32	1" - 1¼"	M32	#	19.0	26.5	15.5	21.2	61.6	77	46.0	50.5
C2	M40	1" - 1¼"	M40	#	25.0	32.5	22.0	28.0	64.6	77	55.0	60.6
D	M50	1" - 1¼"	M50	#	31.5	44.4/42.3	27.5	34.8	83.2	77	65.0	70.8
E	M63	1" - 1¼"	M63	#	42.5	56.3/54.3	39.0	46.5	83.2	77	80.0	88.0
F	M75	1" - 1¼"	M75	#	54.5	68.2/65.3	49.5	58.3	86.4	77	95.0	104.0

- * Sizes Os and O are available with an M16 thread size. If M16 entry is used on O size Cable Glands the maximum cable inner sheath diameter is limited to 10.9mm.
- # Thread sizes specified with order

ACCESSORIES:

Before cable gland assembly or stripping of the cable gland assembly, consideration should be given to any cable gland accessories that may be required, such as:-

- Shroud, to offer additional corrosion protection.
- Locknut, to secure cable glands into position.
- Sealing washer, to offer additional ingress protection of the enclosure at the cable gland entry.
- Earthtag, to provide an external armour/braid bonding point.
- Serrated washer, to dampen any vibrations that may loosen the locknut or cable gland assembly.

SCHEDULE OF LIMITATIONS - ATEX / IECEx:

1. These cable gland types are only suitable for use with fixed apparatus, the cable for which must be effectively clamped and cleated elsewhere.
2. This cable gland has an operating temperature range of -60°C to +100°C.
3. A seal must be formed between the equipment and the cable gland to maintain the appropriate degree of protection against ingress of dust, solid objects and water.

TORQUE VALUES

All torque values below were generated on metallic mandrels. For cable, it is recommended that the assembly instructions are followed.

Torque Figures N/m									
Gland Size	Os	O	A	B	C	C2	D	E	F
CouplerTorque	30	30	32.5	47.5	55	65	82.5	97.5	115

NOTES - c CSA us:

1. The cable used must have extruded sealing (solid polymeric) completely surrounding the "core" (insulation and conductor), allowing for no holes or ventilation through the inner jacket or along the cores.
2. The 501/4** series cable gland connectors, when used in Class 1 Division 2 Classified areas, are not suitable to be interfaced with an explosion proof enclosure containing arcing and sparking devices, unless installed in conjunction with an approved explosion proof sealing fitting.
3. Class 1 Division 2 suitable for use with conduits and cable glands for use in Marine Shipboard applications only according to CSA Standard 245 and IEEE45 / IEC 600092-353 Standards, or certified equivalent, for use on Shipboards and Offshore Rigs / Platforms only.
4. Must comply with Canadian Electrical Code and National Electric Code requirements for threaded entries.
5. For Exe applications, a sealing washer or thread sealant may be required between the enclosure and the gland to maintain the IP rating of the enclosure.
6. When used with unarmoured or braided cables the glands are only suitable for use with fixed apparatus and the cable must be effectively clamped and cleated elsewhere.
7. This cable gland may only be installed when temperature is above -5°C. After completion of the installation, the assembly is then suitable for -60°C to +100°C.

EU Declaration of Conformity in accordance with European Directive 2014/34/EU

Manufacturer: Hawke International

Address: Oxford Street West, Ashton-under-Lyne, OL7 0NA, United Kingdom.

Equipment Type: Range of Group II Compression Cable Glands types: 501/414

Provisions of the Directive fulfilled by the Equipment: Group II Category 2GD Exeb IIC Gb, Exdb IIC Gb, Extb IIIC Db – IP66/67

Notified Body for EU-Type Examination: CML 2776 Chester UK

EU-type Examination Certificate: CML19ATEX1167X

Notified Body for production: SGS-Baseefa 1180 Buxton UK

Harmonised Standards used: EN 60079-0:2018, EN60079-1:2014, EN60079-7:2015, EN60079-31:2014

On behalf of the above named company, I declare that, on the date the equipment accompanied by this declaration is placed on the market, the equipment conforms with all technical and regulatory requirements of the above listed directives.



A. Tindall
Technical Manager